

VS35R-DI-FM-SH-12

VALVOLA DI MASSIMA PRESSIONE A DOPPIO EFFETTO AD AZIONE DIRETTA CON OTTURATORE CONICO E COLLETTORE FLANGIATO

DOUBLE RELIEF, DIRECT ACTING POPPET TYPE VALVE WITH FLANGEABLE BODY

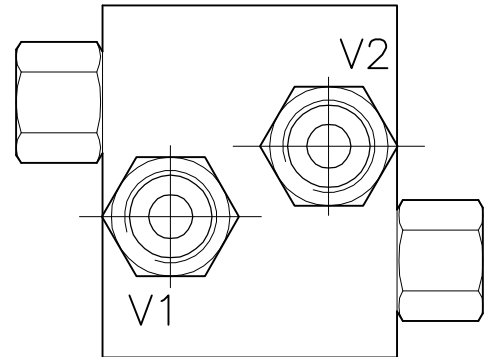
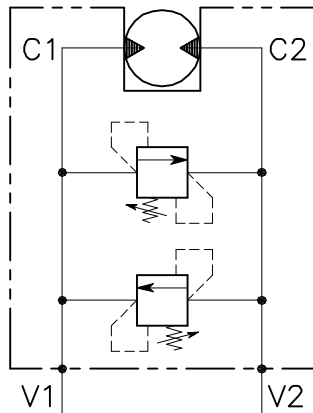

CARATTERISTICHE

Luce nominale	DN 6
Portata min/max	1/35 l/min - 0.26/9 GPM
Pressione di lavoro max.	350 bar - 5075 PSI
Pressione max. di taratura	350 bar - 5075 PSI
Temperatura ambiente	-30°C + 50°C
Temperatura olio	-30°C + 80°C
Filtraggio consigliato	30 micron
Coppia di serraggio	75±85 Nm
Peso	1.088 Kg

PERFORMANCE

Rated size
Min/max flow-rate
Max working pressure
Max setting pressure
Room temperature
Oil temperature
Recommended filtration
Tightening torque
Weight

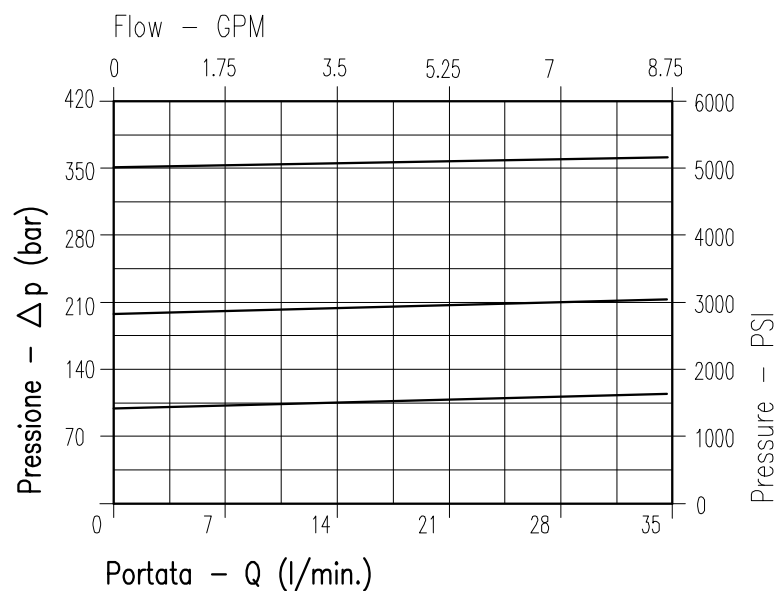

Viscosità olio 46 cSt a 50°C
Oil viscosity 46 cSt at 50°C

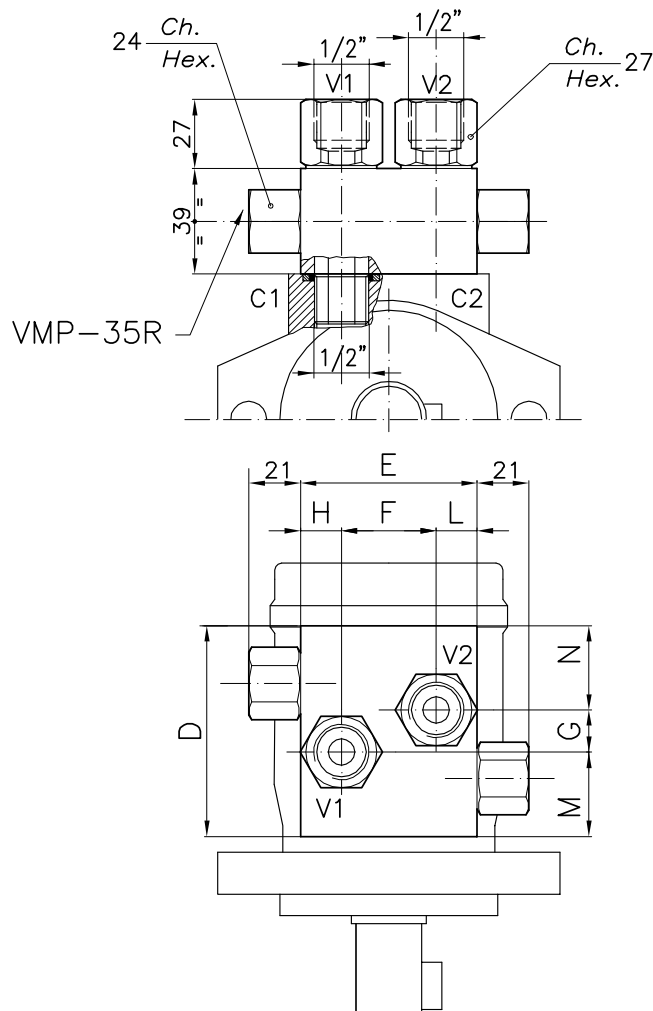

DIMENSIONI DIMENSIONS

Campo taratura Setting range			D	E	F	G	H	L	M	N	TIPO MOTORE MOTOR TYPE
079	078	080	75	80	40	8	20	20	31	36	SAMHYDRAULIK AG/BG/AR

CODICE DI ORDINAZIONE HOW TO ORDER

007 079 0 0 0

Campo taratura / Setting range					
079		078		080	
Campo taratura 5÷100 bar (molla colore blu)		Campo taratura 10÷210 bar (molla colore verde)		Campo taratura 20÷350 bar (molla colore giallo)	
Setting range 5÷100 bar (blue spring)		Setting range 10÷210 bar (green spring)		Setting range 20÷350 bar (yellow spring)	
Taratura standard (Q=5 l/1')	Incr. press. - bar giro/vite	Taratura standard (Q=5 l/1')	Incr. press. - bar giro/vite	Taratura standard (Q=5 l/1')	Incr. press. - bar giro/vite
Std. bar setting (Q=5 l/1')	Pressure rise - turn of screw	Std. bar setting (Q=5 l/1')	Pressure rise - turn of screw	Std. bar setting (Q=5 l/1')	Pressure rise - turn of screw
80 bar	(--)	180 bar	(--)	220 bar	(--)