

VST-T-45-C-...-L-...

REGOLATORE DI FLUSSO A CARTUCCIA BIDIREZIONALE CON COLLETTORE IN LINEA

CARTRIDGE STYLE FLOW RESTRICTOR VALVE IN LINE BODY

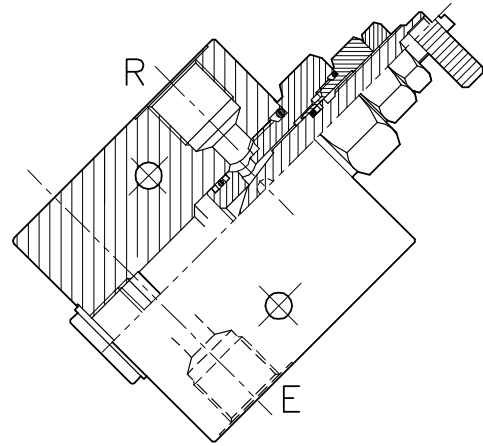
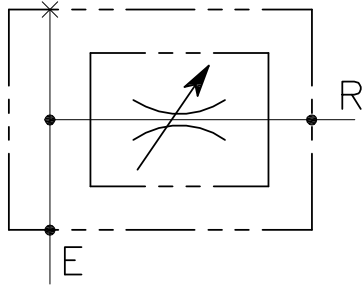

CARATTERISTICHE

Luce nominale	DN 7
Portata min/max	1/45 l/min - 0.26/11.9 GPM
Pressione di lavoro max.	350 bar - 5075 PSI
Temperatura ambiente	-30°C + 50°C
Temperatura olio	-30°C + 80°C
Filtraggio consigliato	30 micron
Peso	0.590 Kg. 3/8" GAS
Peso	0.591 Kg. 1/2" GAS

PERFORMANCE

Rated size
Min/max flow-rate
Max working pressure
Room temperature
Oil temperature
Recommended filtration
Weight
Weight

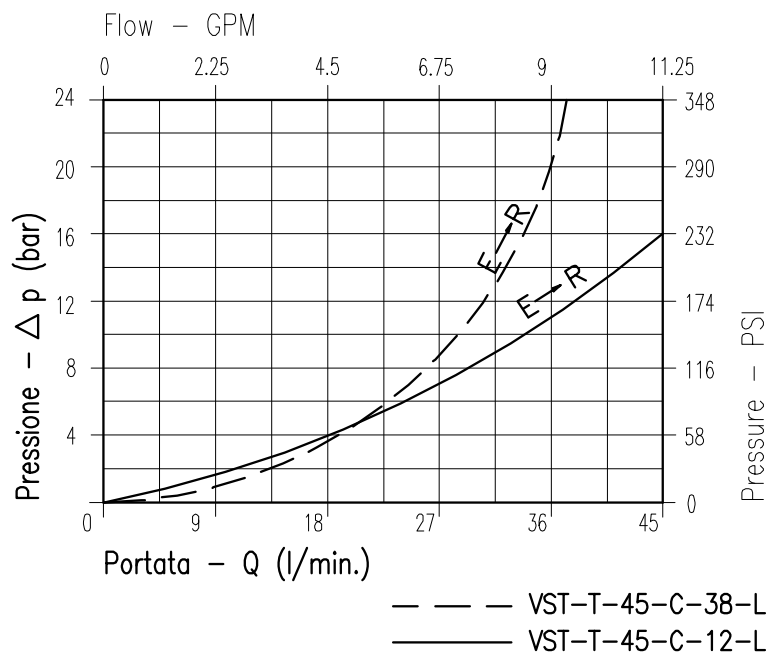

Viscosità olio 46 cSt a 50°C
Oil viscosity 46 cSt at 50°C

REGOLAZIONE
ADJUSTMENT →

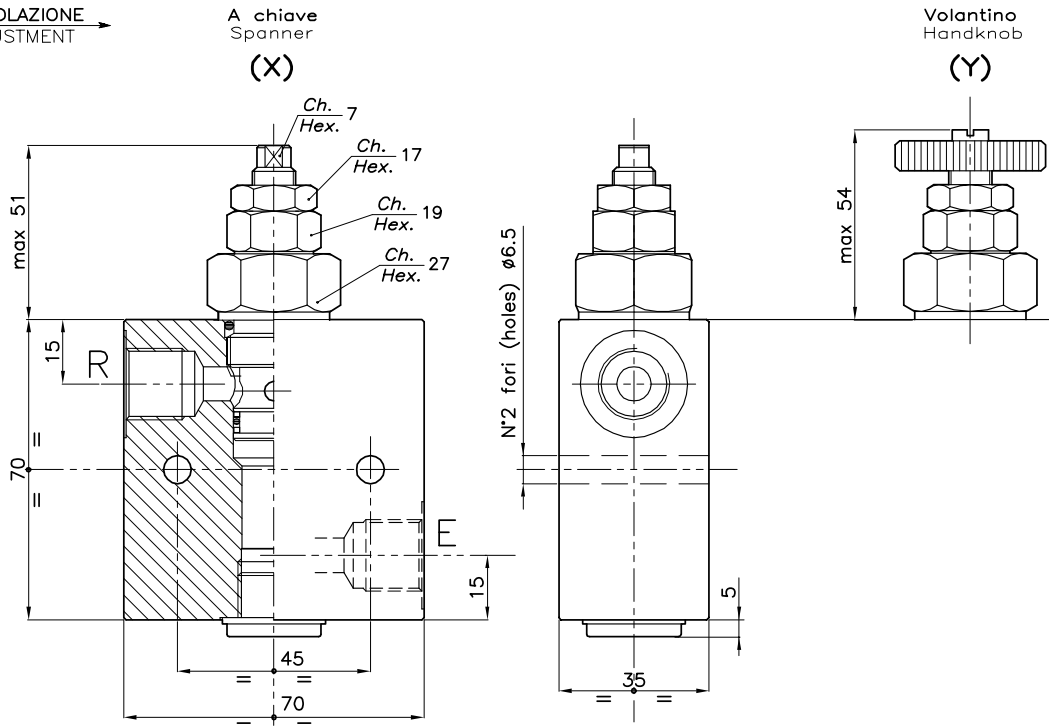

DIMENSIONI DIMENSIONS

NUMERO VALVOLA VALVE NUMBER	Attacchi Port size E-R GAS (BSPP)
175	3/8"
177	1/2"

ESEMPIO TIPICO DI CIRCUITO TYPICAL CIRCUIT EXAMPLE

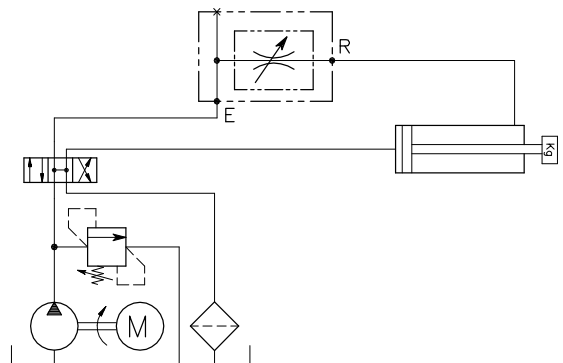

CODICE DI ORDINAZIONE HOW TO ORDER

004 175 0 X 0

Numero valvola / Valve number
175
177

Regolazione
Adjustment
X | A chiave - Spanner
Y | Volantino - handknob