

VSW-VMP-DII-12-FM...

VALVOLA DI MASSIMA PRESSIONE A DOPPIO EFFETTO AD AZIONE DIRETTA CON OTTURATORE CONICO E COLLETTORE FLANGIATO

DOUBLE RELIEF, DIRECT ACTING POPPET TYPE VALVE WITH FLANGEABLE BODY

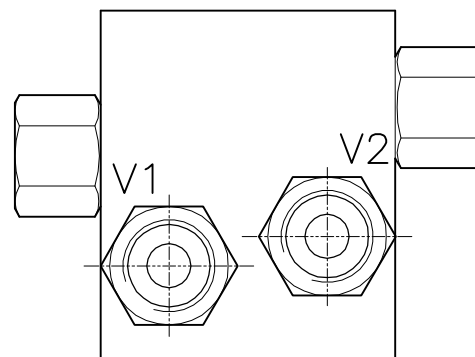
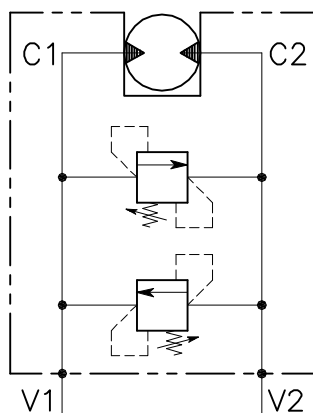

CARATTERISTICHE

Luce nominale	DN 6
Portata min/max	1/35 l/min - 0.26/9 GPM
Pressione di lavoro max.	350 bar - 5075 PSI
Pressione max. di taratura	350 bar - 5075 PSI
Temperatura ambiente	-30°C + 50°C
Temperatura olio	-30°C + 80°C
Filtraggio consigliato	30 micron
Coppia di serraggio	75-85 Nm
Peso	1.258 Kg

PERFORMANCE

Rated size
Min/max flow-rate
Max working pressure
Max setting pressure
Room temperature
Oil temperature
Recommended filtration
Tightening torque
Weight

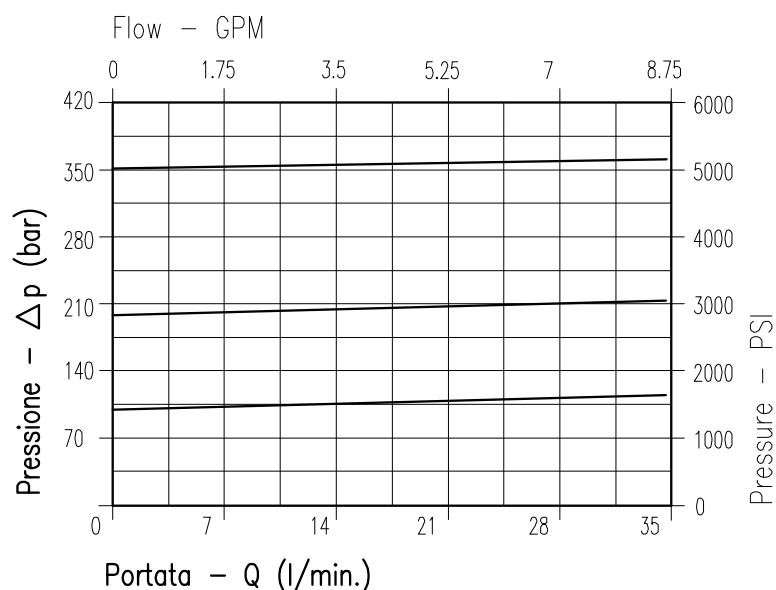

Viscosità olio 46 cSt a 50°C
Oil viscosity 46 cSt at 50°C

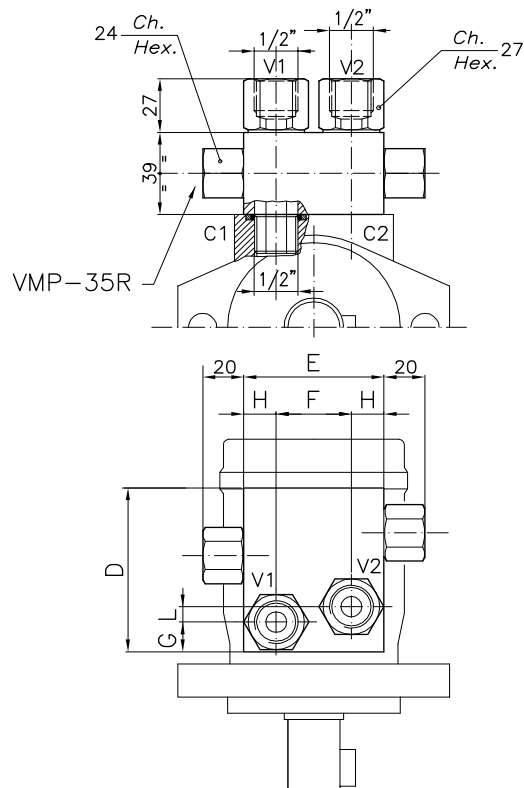
**DIMENSIONI
DIMENSIONS**

Campo taratura Setting range			D	E	F	G	H	L	TIPO MOTORE MOTOR TYPE	
045	044	031	110	90	25.4	19.6	32.3	26.4	CHAR-LYNN 2000"	FMCHD
035	034	016	90	80	45.7	15	22.15	0	TRW MAC-MAF CHAR-LYNN S-PLUS	FMCHAR
043	042	028	94	80	40	22	20	8	SAMHYDRAULIK AG/BG/AR	FMSH
060	084	085	115	90	36	16	27	36	DANFOSS OMR/OMP	FM OMR OMP

**CODICE DI ORDINAZIONE
HOW TO ORDER**

007 045 0 0 0

Campo taratura / Setting range					
045		044		031	
035		034		016	
043		042		028	
060		084		085	
Campo taratura 5÷100 bar (molla colore blu) Setting range 5÷100 bar (blue spring)		Campo taratura 10÷210 bar (molla colore verde) Setting range 10÷210 bar (green spring)		Campo taratura 20÷350 bar (molla colore giallo) Setting range 20÷350 bar (yellow spring)	
Taratura standard (Q=5 l/1')	Incr. press. - bar giro/vite	Taratura standard (Q=5 l/1')	Incr. press. - bar giro/vite	Taratura standard (Q=5 l/1')	Incr. press. - bar giro/vite
Std. bar setting (Q=5 l/1')	Pressure rise - turn of screw	Std. bar setting (Q=5 l/1')	Pressure rise - turn of screw	Std. bar setting (Q=5 l/1')	Pressure rise - turn of screw
80 bar	(--)	180 bar	(--)	220 bar	(--)