

WR-CC1-DE-38-FC1-...

VALVOLA BILANCIAMENTO, BLOCCO E CONTROLLO MOVIMENTO A DOPPIO EFFETTO CON FUNZIONE RIGENERATIVA

DOUBLE COUNTERBALANCE VALVE WITH REGENERATIVE FUNCTION

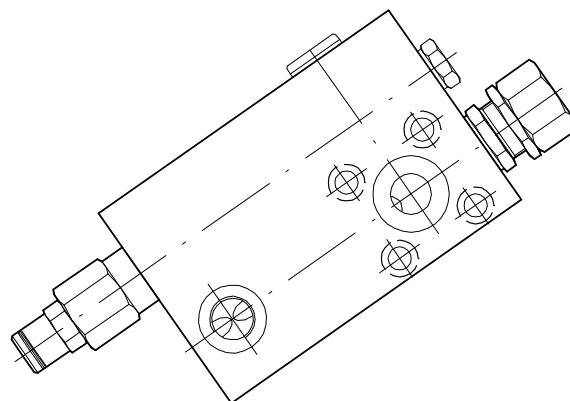
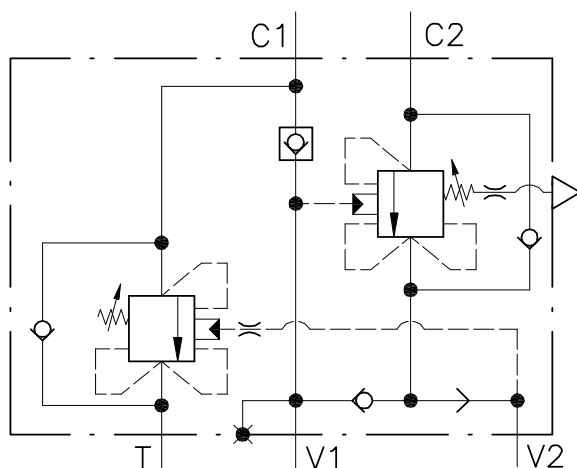

CARATTERISTICHE

Luca nominale	DN 8
Portata max in V1.V2	30 l/min - 7.9 GPM
Pressione di lavoro max.	350 bar - 5075 PSI
Pressione max. di taratura	350 bar - 5075 PSI
Temperatura ambiente	-30°C + 50°C
Temperatura olio	-30°C + 80°C
Filtraggio consigliato	30 micron
Peso	

PERFORMANCE

Rated size
Max flow in V1.V2 port
Max working pressure
Max setting pressure
Room temperature
Oil temperature
Recommended filtration
Weight

NOTE:

La taratura deve essere **1.3** volte maggiore della pressione indotta dal carico.

Valve should be set at **1.3** times load induced pressure.

ESEMPIO/EXAMPLE:

Pressione di lavoro max:

Max working pressure:

350 bar / 1.3 = 270 bar

Valvola con scarico rapido da C1 - portata massima 60 l/min.

Valve with a fast discharge from C1 - 60 l/min maximum flow rate.

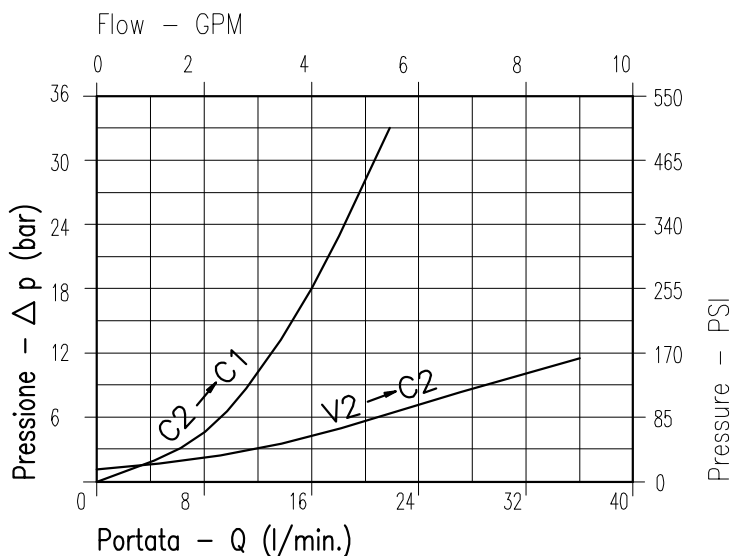

Viscosità olio 46 cSt a 50°C
Oil viscosity 46 cSt at 50°C

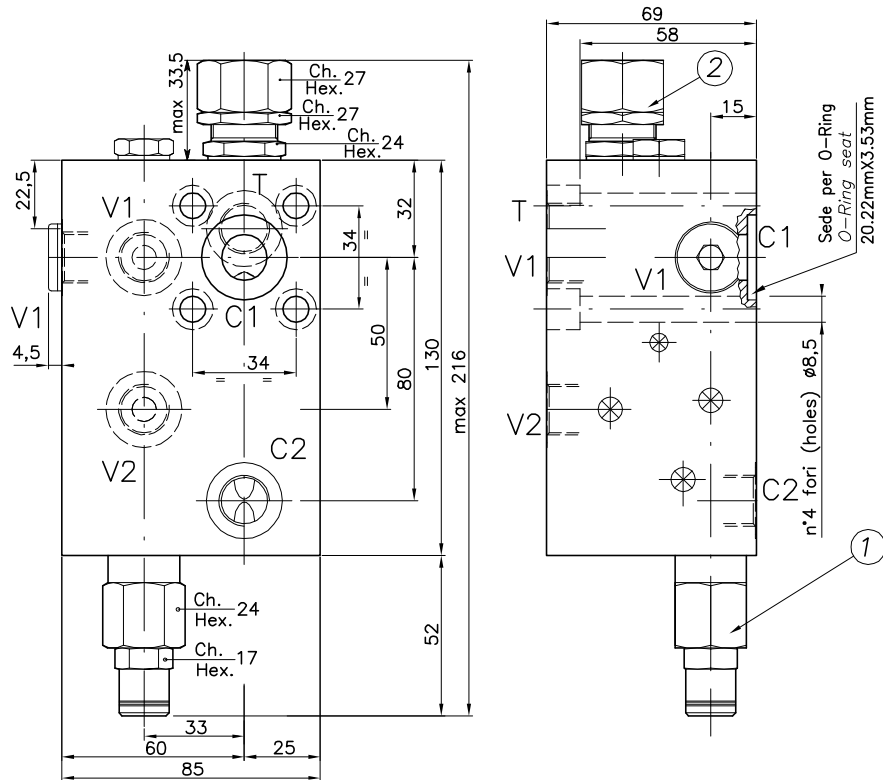

ESEMPIO TIPICO DI CIRCUITO TYPICAL CIRCUIT EXAMPLE

DIMENSIONI DIMENSIONS

Campo taratura Setting range	Attacchi filettati Threaded connections Bocche - Ports ISO 1179-1 (BSPP) V2-C2 / V1-r	Attacchi filettati Threaded connections Bocche - Ports non standard C1
105	G3/8	34x34 OR4081(2-211)

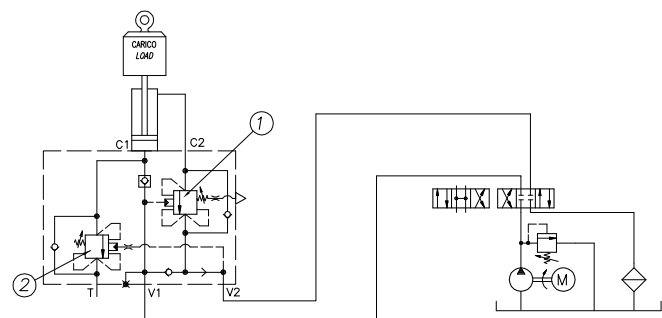

CODICE DI ORDINAZIONE HOW TO ORDER

