

WR-DE-38-L-...

VALVOLA BILANCIAMENTO, BLOCCO E CONTROLLO MOVIMENTO A DOPPIO EFFETTO CON FUNZIONE RIGENERATIVA
DOUBLE COUNTERBALANCE VALVE WITH REGENERATIVE FUNCTION

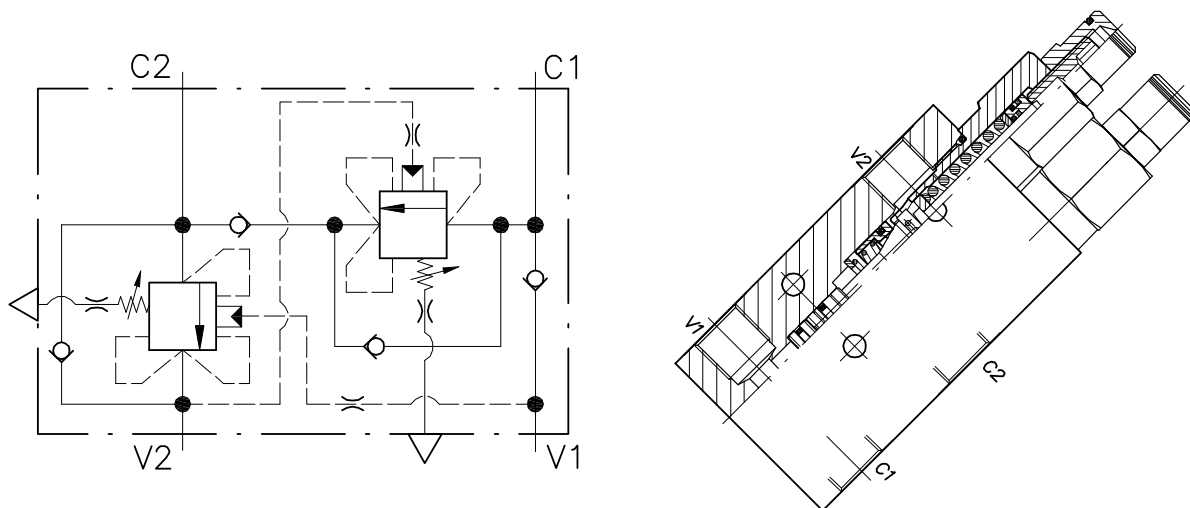

CARATTERISTICHE

Luca nominale	DN 8
Portata max in V1.V2	30 l/min - 7.9 GPM
Pressione di lavoro max.	350 bar - 5075 PSI
Pressione max. di taratura	350 bar - 5075 PSI
Temperatura ambiente	-30°C + 50°C
Temperatura olio	-30°C + 80°C
Filtraggio consigliato	30 micron
Peso	

PERFORMANCE

Rated size
Max flow in V1.V2 port
Max working pressure
Max setting pressure
Room temperature
Oil temperature
Recommended filtration
Weight

NOTE:

La taratura deve essere **1.3** volte maggiore della pressione indotta dal carico.

Valve should be set at **1.3** times load induced pressure.

ESEMPIO/EXAMPLE:

Pressione di lavoro max:

Max working pressure:

350 bar / 1.3 = 270 bar

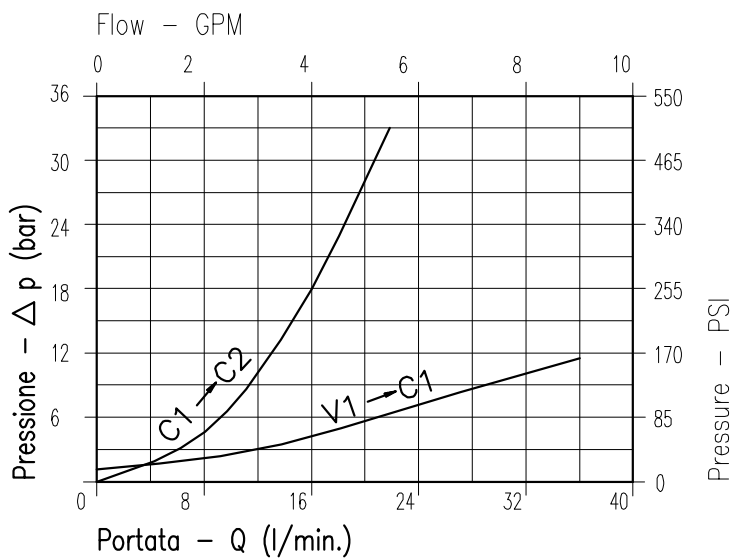

Viscosità olio 46 cSt a 50°C
Oil viscosity 46 cSt at 50°C

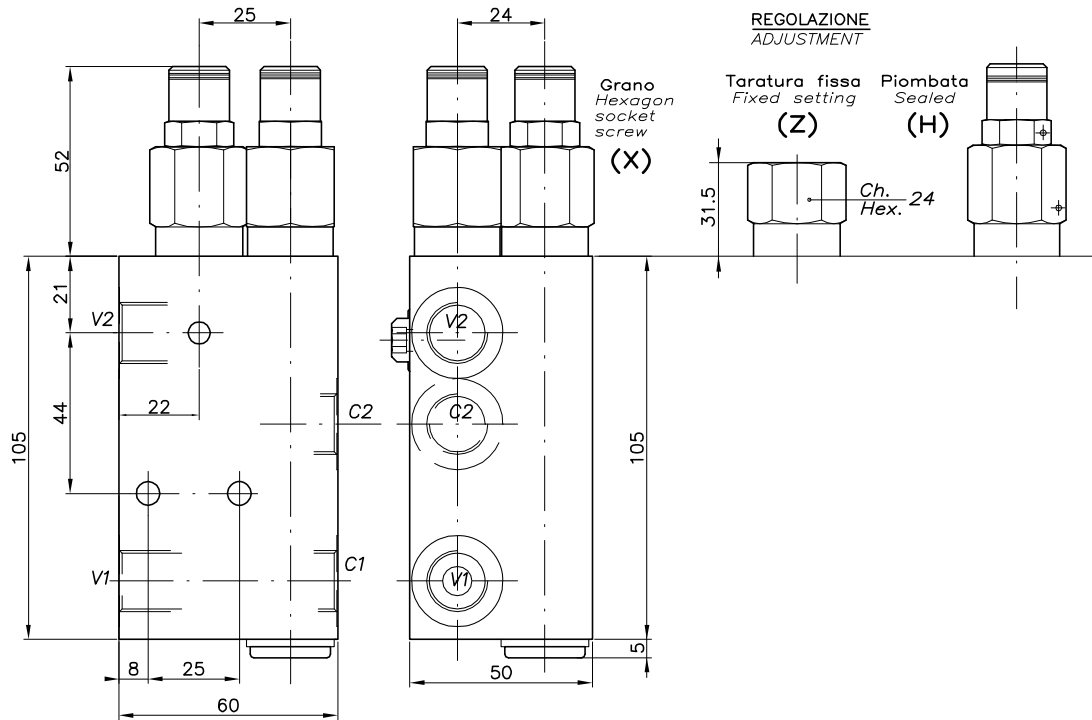

ESEMPIO TIPICO DI CIRCUITO TYPICAL CIRCUIT EXAMPLE

DIMENSIONI DIMENSIONS

Campo taratura Setting range	Attacchi filettati Threaded connections Bocche - Ports ISO 1179-1 (BSPP) V2-C2 / V1-C1
152	G3/8

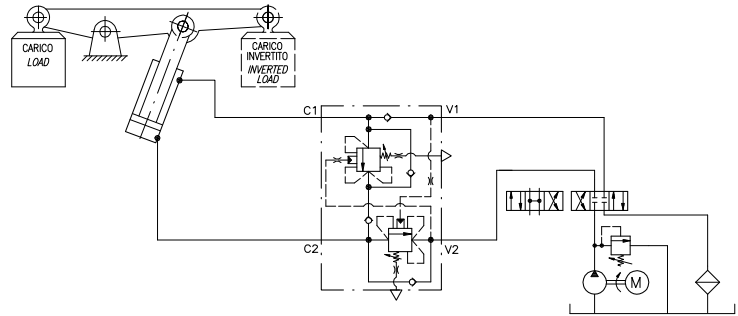

CODICE DI ORDINAZIONE HOW TO ORDER

006 152 0 X 0

Campo taratura / Setting range	
152	
Campo taratura 60÷350 bar (molla colore giallo) Setting range 60÷350 bar (yellow spring)	
Taratura standard (Q=5 l/1') Std. bar setting (Q=5 l/1') 350 bar	Incr. press. - bar giro/vite Pressure rise - bar/turn of screw (138)

Rapporto di pilotaggio Pilot ratios	
O	4.25 : 1
D	8 : 1

Regolazione Adjustment	
X	Grano - Dowel
Z	Taratura fissa - Fixed setting
H	Piombata - Sealed