

ORDER FORM FOR MMFU

Standard execution (MMFU-25-V-1-MI004)

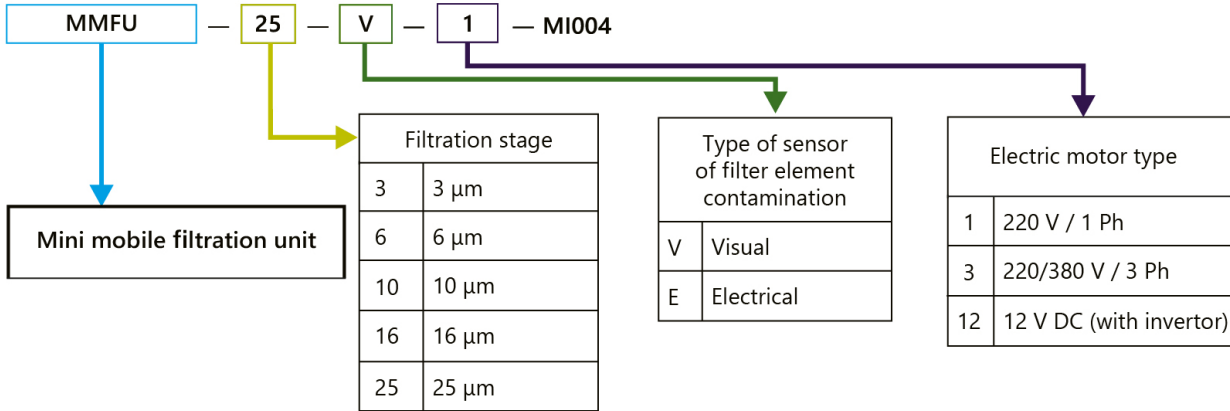

ORDER FORM FOR MFU1

Standard execution (MFU1-40-25-3-V-MI002)

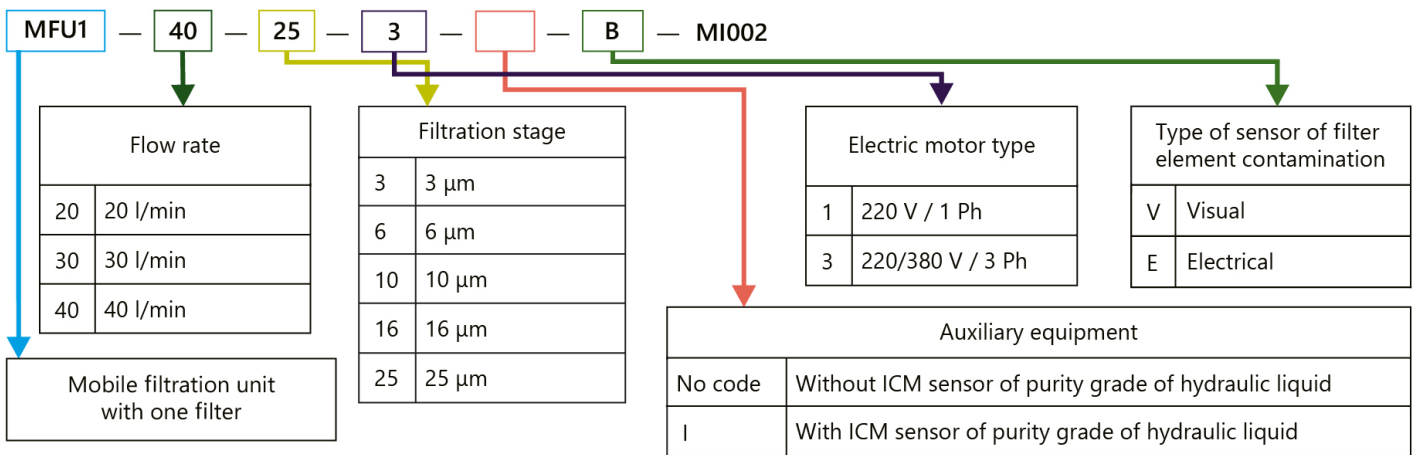

ORDER FORM FOR MFU2

Standard execution (MFU2-80-25-10-3-V-MI003)

