

Series ML 170-450 2320 PSI

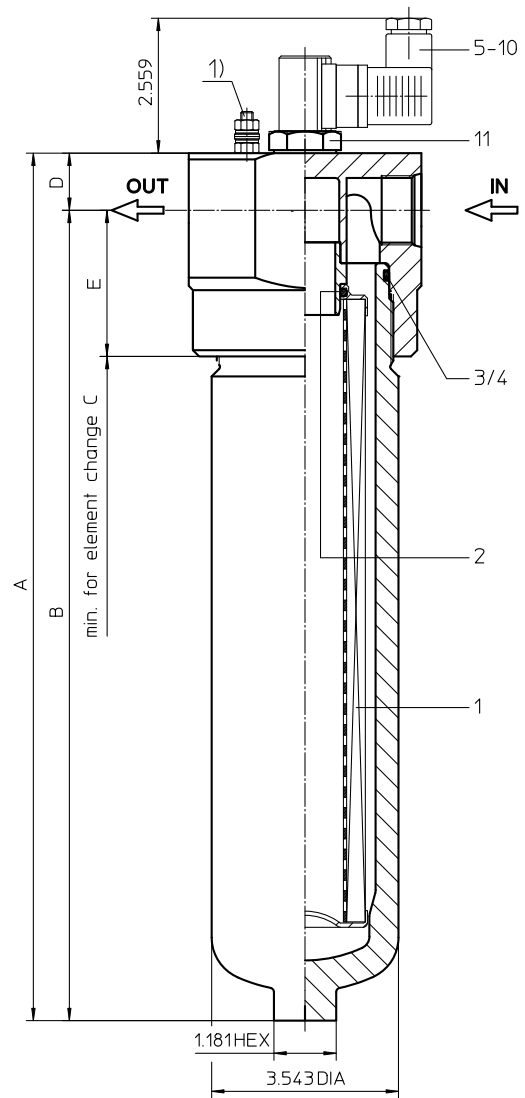
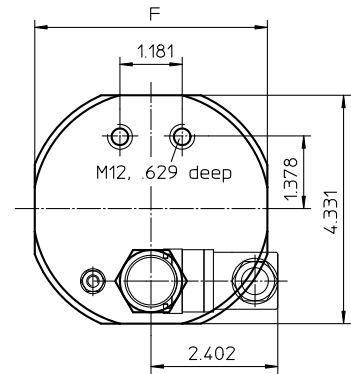

Dimensions:

type	ML 170	ML 240	ML 360	ML 450
connection	-16 SAE			
A	11.33	13.30	16.45	20.59
B	10.23	12.20	15.35	19.48
C	13.77	15.74	18.89	23.03
D	1.10	1.10	1.10	1.10
E	2.76	2.76	2.76	2.76
F	4.40	4.40	4.40	4.40
weight	16.5 lbs.	18.7 lbs.	22.2 lbs.	28.8 lbs.
volume tank	.18 Gal.	.23 Gal.	.31 Gal.	.42 Gal.

type	ML 170	ML 240	ML 360	ML 450
connection	-24 SAE			
A	11.81	13.77	16.92	21.06
B	10.43	12.40	15.55	19.68
C	13.77	15.74	18.89	23.03
D	1.37	1.37	1.37	1.37
E	2.95	2.95	2.95	2.95
F	4.56	4.56	4.56	4.56
weight	17.3 lbs.	19.5 lbs.	23.1 lbs.	29.7 lbs.
volume tank	.18 Gal.	.23 Gal.	.31 Gal.	.42 Gal.

1) Connect the stand grounding tab to a suitable earth ground point.

Dimensions: inches

Designs and performance values are subject to change.



Powering Business Worldwide

Pressure Filter

Series ML 170-450

2320 PSI

Description:

Pressure filter series ML 170-450 have a working pressure up to 2320 PSI. Pressure peaks can be absorbed with a sufficient safety margin. The ML-filter is in-line mounted.

The filter element consists of star-shaped, pleated filter material, which is supported on the inside by a perforated core tube and is bonded to the end caps with a high-quality adhesive. The flow direction is from outside to inside. Filter elements are available down to 5 $\mu\text{m}_{(c)}$. Finer filtration is available upon request.

Eaton filter elements are known for high intrinsic stability and an excellent filtration capability, a high dirt-retaining capacity and a long service life.

Eaton filter elements are suitable for all petroleum based fluids, HW-emulsions, most synthetic hydraulic fluids and lubrication oils.

Eaton filter elements are available up to a pressure resistance of Δp 2320 PSI and a rupture strength of Δp 3625 PSI.

The internal valve is integrated into the filter head. After reaching the bypass pressure setting, the bypass valve will send unfiltered partial flow around the filter.

The reversing valve provides another level of protection for the filter element. The reverse flow will not be filtered.

1. Type index:

1.1. Complete filter: (ordering example)

ML. 360. 10VG. HR. E. P. -. UG. 5. -. -. AE

1	2	3	4	5	6	7	8	9	10	11	12
---	---	---	---	---	---	---	---	---	----	----	----

1 series:

ML = in-line filter-medium pressure range

2 nominal size: 170, 240, 360, 450

3 filter-material and filter-fineness:

80G, 40G, 25G, 10G stainless steel wire mesh
25VG, 16VG, 10VG, 6VG, 3VG microglass

4 filter element collapse rating:

30 = Δp 435 PSI
HR = Δp 2320 PSI (rupture strength Δp 3625 PSI)

5 filter element design:

E = single-end open

6 sealing material:

P = Nitrile (NBR)
V = Viton (FPM)

7 filter element specification: (see catalog)

- = standard
VA = stainless steel
IS06 = for HFC applications, see sheet-no. 31601

8 process connection:

UG = thread connection

9 process connection size:

5 = -16 SAE
7 = -24 SAE

10 filter housing specification: (see catalog)

- = standard
IS06 = for HFC applications, see sheet-no. 31605

11 internal valve:

- = without
S1 = with by-pass valve Δp 51 PSI
S2 = with by-pass valve Δp 102 PSI
R = reversing valve, $Q \leq 55.75$ GPM

12 clogging indicator or clogging sensor:

- = without
AOR = visual, see sheet-no. 1606
AOC = visual, see sheet-no. 1606
AE = visual-electric, see sheet-no. 1615
VS5 = electronic, see sheet-no. 1619

To add an indicator to your filter, use the corresponding indicator data sheet to find the indicator details and add them to the filter assembly model code.

1.2. Filter element: (ordering example)

01E. 360. 10VG. HR. E. P. -

1	2	3	4	5	6	7
---	---	---	---	---	---	---

1 series:

01E. = filter element according to company standard

2 nominal size: 170, 240, 360, 450

3 - 7 see type index-complete filter

Technical data:

design temperature:	14 °F to +212 °F
operating temperature:	14 °F to +176 °F
operating medium	mineral oil, other media on request
max. operating pressure:	2320 PSI
test pressure:	3320 PSI
process connection:	thread connection
housing material:	Al; C-steel
sealing material:	Nitrile (NBR) or Viton (FPM), other materials on request
installation position:	vertical

Classified under the Pressure Equipment Directive 2014/68/EC for mineral oil (fluid group 2), Article 4, Para. 3.
 Classified under ATEX Directive 2014/34/EC according to specific application (see questionnaire sheet-no. 34279-4).

Pressure drop flow curves:

Filter calculation/sizing

The pressure drop of the assembly at a given flow rate Q is the sum of the housing Δp and the element Δp and is calculated as follows:

$$\Delta p_{assembly} = \Delta p_{housing} + \Delta p_{element}$$

$$\Delta p_{housing} = (\text{see } \Delta p = f(Q) \text{ - characteristics})$$

$$\Delta p_{element} (PSI) = Q (GPM) \times \frac{MSK}{1000} \left(\frac{PSI}{GPM} \right) \times v(SUS) \times \frac{\rho}{0.876} \left(\frac{kg}{dm^3} \right)$$

For ease of calculation our Filter Selection tool is available online at www.eatonpowersource.com/calculators/filtration/

Material gradient coefficients (MSK) for filter elements

The material gradient coefficients in PSI/GPM apply to mineral oil (HLP) with a density of 0.876 kg/dm³ and a kinematic viscosity of 139 SUS (30 mm²/s). The pressure drop changes proportionally to the change in kinematic viscosity and density.

ML	VG					G		
	3VG	6VG	10VG	16VG	25VG	25G	40G	80G
170	2.714	1.884	1.206	1.036	0.708	0.0839	0.0783	0.0537
240	2.092	1.452	0.930	0.799	0.546	0.0651	0.0607	0.0416
360	1.530	1.062	0.680	0.584	0.399	0.0475	0.0444	0.0304
450	1.126	0.782	0.500	0.430	0.294	0.0349	0.0326	0.0223

$\Delta p = f(Q)$ – characteristics according to ISO 3968

The pressure drop characteristics apply to mineral oil (HLP) with a density of 0.876 kg/dm³. The pressure drop changes proportionally to the density.

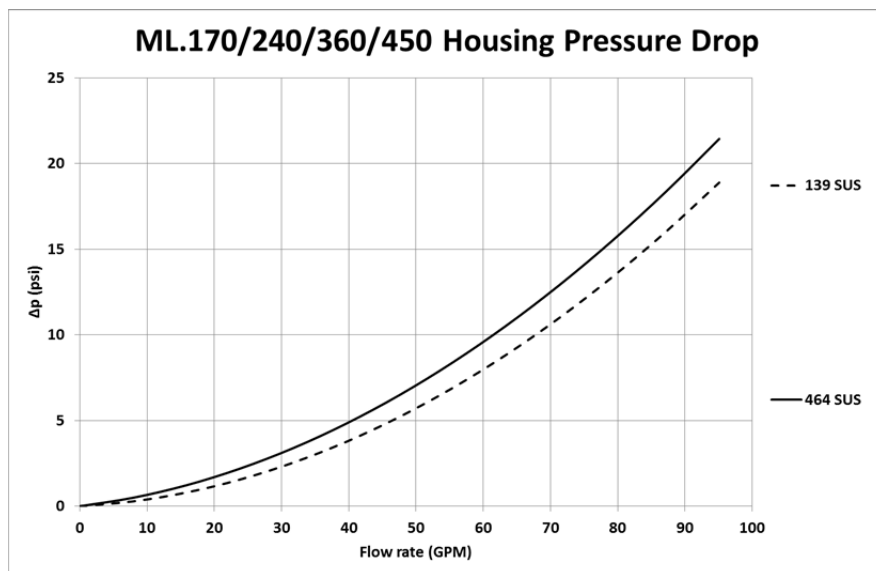

Symbols:

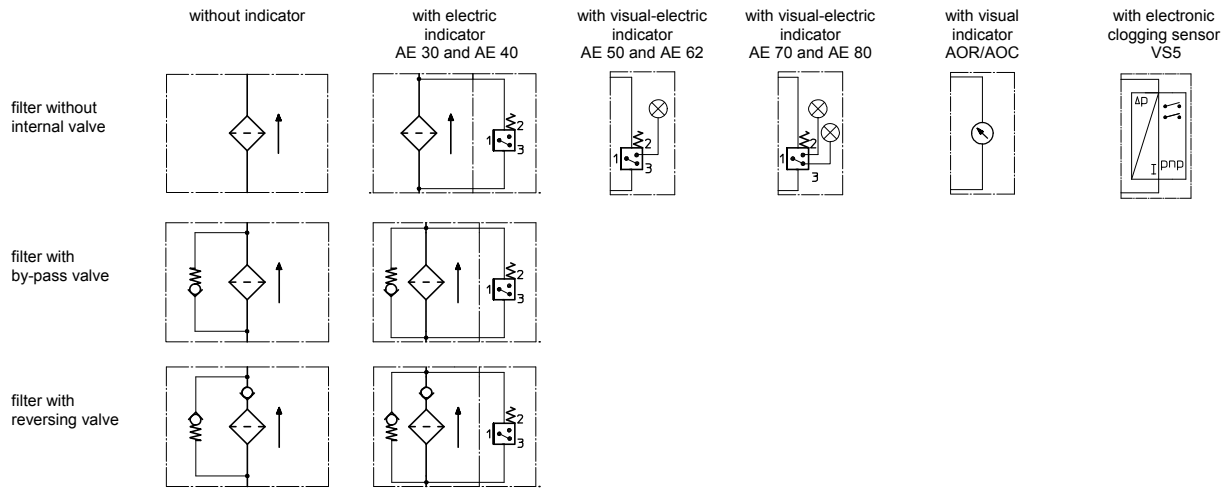

Spare parts:

item	qty.	designation	dimension				article-no.	
			ML 170	ML 240	ML 360	ML 450		
1	1	filter element	01E.170...	01E.240...	01E.360...	01E.450...		
2	1	O-ring	34 x 3,5				304338 (NBR)	304730 (FPM)
3	1	O-ring	75 x 3				302215 (NBR)	304729 (FPM)
4	1	support ring	81 x 2,6 x 1				304581	
5	1	clogging indicator visual	AOR or AOC				see sheet-no. 1606	
6	1	clogging indicator visual-electric	AE				see sheet-no. 1615	
7	1	clogging sensor electronic	VS5				see sheet-no. 1619	
8	1	O-ring	15 x 1,5				315357 (NBR)	315427 (FPM)
9	1	O-ring	22 x 2				304708 (NBR)	304721 (FPM)
10	1	O-ring	14 x 2				304342 (NBR)	304722 (FPM)
11	1	screw plug	20913-4				309817	

item 11 execution only without clogging indicator or clogging sensor

Test methods:

Filter elements are tested according to the following ISO standards:

ISO 2941	Verification of collapse/burst resistance
ISO 2942	Verification of fabrication integrity
ISO 2943	Verification of material compatibility with fluids
ISO 3723	Method for end load test
ISO 3724	Verification of flow fatigue characteristics
ISO 3968	Evaluation of pressure drop versus flow characteristics
ISO 16889	Multi-pass method for evaluating filtration performance

North America

44 Apple Street
Tinton Falls, NJ 07724
Toll Free: 800 656-3344
(North America only)
Tel: +1 732 212-4700

Europe/Africa/Middle East

Auf der Heide 2
53947 Nettersheim, Germany
Tel: +49 2486 809-0

Friedensstraße 41
68804 Altlußheim, Germany
Tel: +49 6205 2094-0

An den Nahewiesen 24
55450 Langenlonsheim, Germany
Tel: +49 6704 204-0

China

No. 3, Lane 280,
Linhong Road
Changning District, 200335
Shanghai, P.R. China
Tel: +86 21 5200-0099

Singapore

4 Loyang Lane #04-01/02
Singapore 508914
Tel: +65 6825-1668

Brazil

Av. Julia Gaioli, 474 – Bonsucesso
07251-500 – Guarulhos, Brazil
Tel: +55 11 2465-8822

For more information, please

email us at filtration@eaton.com
or visit www.eaton.com/filtration

© 2015 Eaton. All rights reserved. All trademarks and registered trademarks are the property of their respective owners. All information and recommendations appearing in this brochure concerning the use of products described herein are based on tests believed to be reliable. However, it is the user's responsibility to determine the suitability for his own use of such products. Since the actual use by others is beyond our control, no guarantee, expressed or implied, is made by Eaton as to the effects of such use or the results to be obtained. Eaton assumes no liability arising out of the use by others of such products. Nor is the information herein to be construed as absolutely complete, since additional information may be necessary or desirable when particular or exceptional conditions or circumstances exist or because of applicable laws or government regulations.

Series ML/MLO 30 2320 PSI

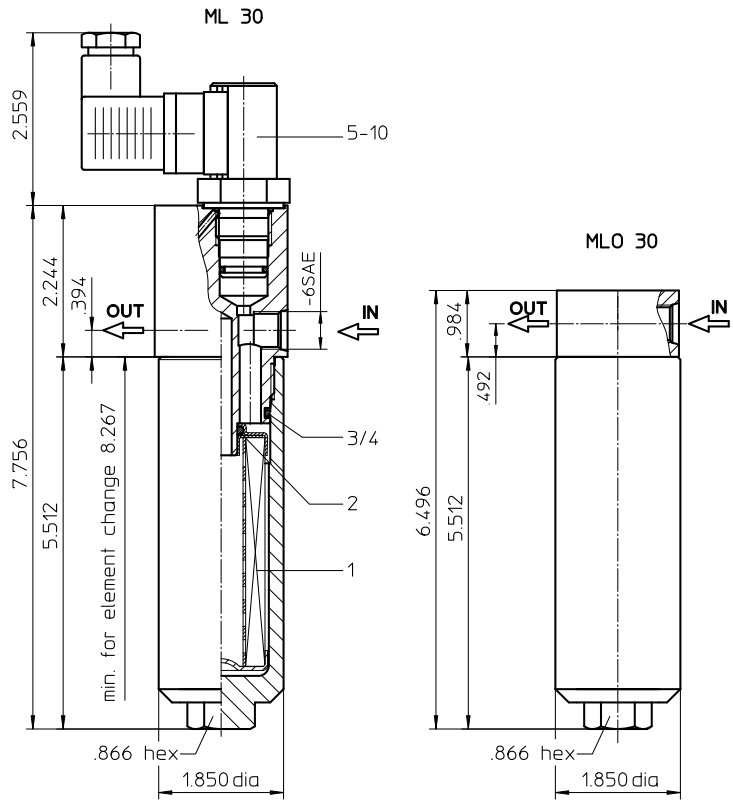
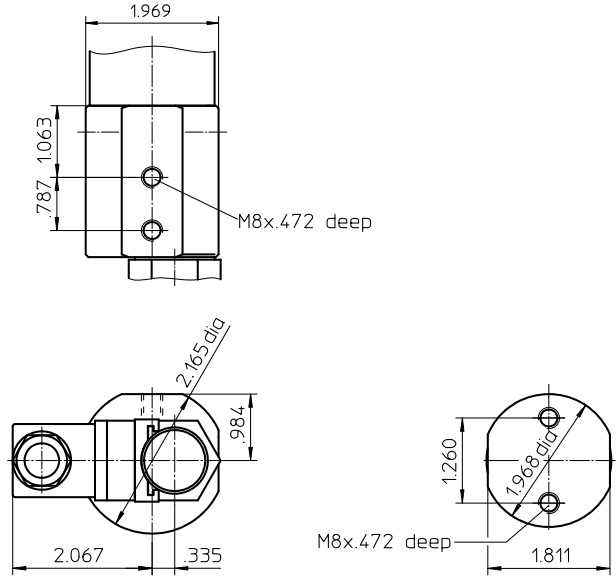

Weight without indicator: approx. 2.50 lbs.
Weight with indicator: approx. 2.90 lbs

Dimensions: inches

Designs and performance values are subject to change.

Pressure Filter

Series ML/MLO 30

2320 PSI

Description:

Pressure filter series ML30 and MLO30, have a working pressure up to 2320 PSI. Pressure peaks can be absorbed with a sufficient safety margin. The Filter is in-line mounted.

The filter element consists of star-shaped, pleated filter material, which is supported on the inside by a perforated core tube and is bonded to the end caps with a high-quality adhesive. The flow direction is from outside to inside. Filter elements are available down to 4 $\mu\text{m}_{(c)}$.

Eaton filter elements are known for high intrinsic stability and an excellent filtration capability, a high dirt-retaining capacity and a long service life.

Eaton filter elements are suitable for all petroleum based fluids, HW-emulsions, most synthetic hydraulic fluids and lubrication oils.

Eaton filter elements are available up to a pressure resistance of Δp 2320 PSI and a rupture strength of Δp 3625 PSI.

1. Type index:

1.1. Complete filter: (ordering example)

ML. 30. 10VG. HR. E. P. - UG. 1. - AE
1 2 3 4 5 6 7 8 9 10 11

1 series:

ML = in-line filter-medium pressure range with indicator
MLO = in-line filter-medium pressure range without indicator

2 nominal size: 30

3 filter-material and filter-fineness:

80G, 40G, 25G, 10G stainless steel wire mesh
25VG, 16VG, 10VG, 6VG, 3VG microglass

4 filter element collapse rating:

30 = Δp 435 PSI
HR = Δp 2320 PSI (rupture strength Δp 3625 PSI)

5 filter element design:

E = single-end open

6 sealing material:

P = Nitrile (NBR)
V = Viton (FPM)

7 filter element specification: (see catalog)

- = standard
VA = stainless steel
IS06 = for HFC applications, see sheet-no. 31601

8 process connection:

UG = thread connection

9 process connection size:

1 = -6 SAE

10 filter housing specification: (see catalog)

- = standard
IS06 = for HFC application, see sheet-no. 31605

11 clogging indicator or clogging sensor:

series MLO:
- = without
series ML:
AOR = visual, see sheet-no. 1606
AOC = visual, see sheet-no. 1606
AE = visual-electric, see sheet-no. 1615
VS5 = electronic, see sheet-no. 1619

To add an indicator to your filter, use the corresponding indicator data sheet to find the indicator details and add them to the filter assembly model code.

1.2. Filter element: (ordering example)

01E. 30. 10VG. HR. E. P. -
1 2 3 4 5 6 7

1 series:

01E. = filter element according to company standard

2 nominal size: 30

3 - 7 see type index-complete filter

Technical data:

design temperature:	14 °F to +212 °F
operating temperature:	14 °F to +176 °F
operating medium	mineral oil, other media on request
max. operating pressure:	2320 PSI
test pressure:	3318 PSI
process connection:	thread connection
housing material:	Al, C-steel
sealing material:	Nitrile (NBR) or Viton (FPM), other materials on request
installation position:	vertical
volume tank:	.02 Gal

Classified under the Pressure Equipment Directive 2014/68/EC for mineral oil (fluid group 2), Article 4, Para. 3.
 Classified under ATEX Directive 2014/34/EC according to specific application (see questionnaire sheet-no. 34279-4).

Pressure drop flow curves:

Filter calculation/sizing

The pressure drop of the assembly at a given flow rate Q is the sum of the housing Δp and the element Δp and is calculated as follows:

$$\Delta p_{assembly} = \Delta p_{housing} + \Delta p_{element}$$

$$\Delta p_{housing} = (\text{see } \Delta p = f(Q) \text{ - characteristics})$$

$$\Delta p_{element} (PSI) = Q (GPM) \times \frac{MSK}{1000} \left(\frac{PSI}{GPM} \right) \times \nu (SUS) \times \frac{\rho}{0.876} \left(\frac{kg}{dm^3} \right)$$

For ease of calculation our Filter Selection tool is available online at www.eatonpowersource.com/calculators/filtration/

Material gradient coefficients (MSK) for filter elements

The material gradient coefficients in psi/gpm apply to mineral oil (HLP) with a density of 0.876 kg/dm³ and a kinematic viscosity of 139 SUS (30 mm²/s). The pressure drop changes proportionally to the change in kinematic viscosity and density.

ML/MLO	VG					G		
	3VG	6VG	10VG	16VG	25VG	25G	40G	80G
30	12.554	8.716	5.580	4.794	3.275	0.2539	0.2369	0.1623

$\Delta p = f(Q)$ – characteristics according to ISO 3968

The pressure drop characteristics apply to mineral oil (HLP) with a density of 0.876 kg/dm³. The pressure drop changes proportionally to the density.

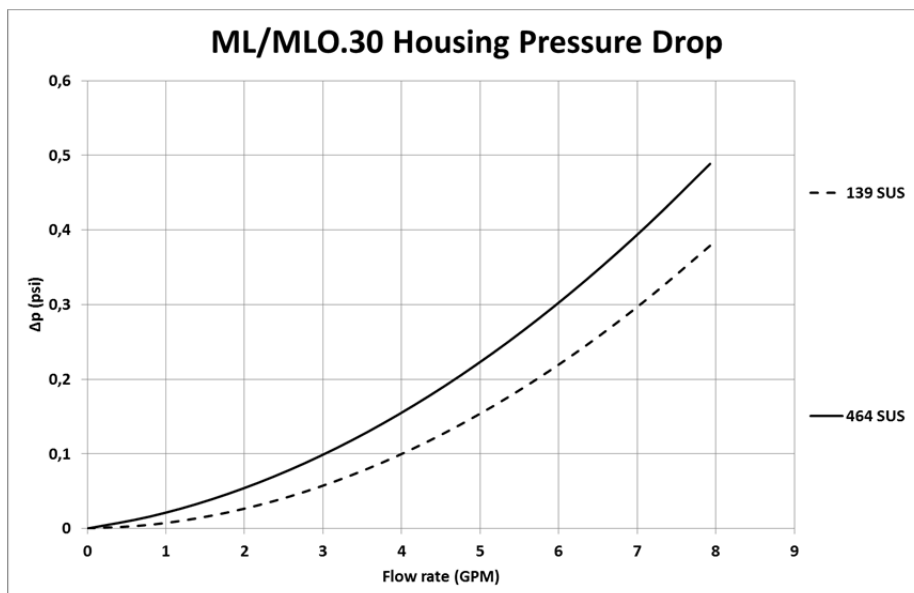

Symbols:

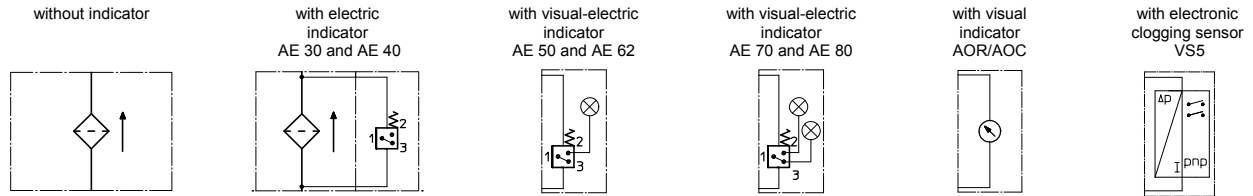

Spare parts:

item	qty.	designation	dimension	article-no.	
1	1	filter element	01E.30...		
2	1	O-ring	11 x 3	312603 (NBR)	312727 (FPM)
3	1	O-ring	32 x 2,5	306843 (NBR)	308268 (FPM)
4	1	support ring	37 x 2,1 x 1	305466	
5	1	clogging indicator, visual	AOR or AOC	see sheet-no. 1606	
6	1	clogging indicator, visual-electric	AE	see sheet-no. 1615	
7	1	clogging sensor, electronic	VS5	see sheet-no. 1619	
8	1	O-ring	15 x 1,5	315357 (NBR)	315427 (FPM)
9	1	O-ring	22 x 2	304708 (NBR)	304721 (FPM)
10	1	O-ring	14 x 2	304342 (NBR)	304722 (FPM)

Test methods:

Filter elements are tested according to the following ISO standards:

ISO 2941	Verification of collapse/burst resistance
ISO 2942	Verification of fabrication integrity
ISO 2943	Verification of material compatibility with fluids
ISO 3723	Method for end load test
ISO 3724	Verification of flow fatigue characteristics
ISO 3968	Evaluation of pressure drop versus flow characteristics
ISO 16889	Multi-pass method for evaluating filtration performance

North America

44 Apple Street
Tinton Falls, NJ 07724
Toll Free: 800 656-3344
(North America only)
Tel: +1 732 212-4700

Europe/Africa/Middle East

Auf der Heide 2
53947 Nettersheim, Germany
Tel: +49 2486 809-0

Friedensstraße 41
68804 Altlußheim, Germany
Tel: +49 6205 2094-0

An den Nahewiesen 24
55450 Langerlonsheim, Germany
Tel: +49 6704 204-0

China

No. 3, Lane 280,
Linhong Road
Changning District, 200335
Shanghai, P.R. China
Tel: +86 21 5200-0099

Singapore

4 Loyang Lane #04-01/02
Singapore 508914
Tel: +65 6825-1668

Brazil

Av. Julia Gaioli, 474 – Bonsucesso
07251-500 – Guarulhos, Brazil
Tel: +55 11 2465-8822

**For more information, please
email us at filtration@eaton.com
or visit www.eaton.com/filtration**

© 2015 Eaton. All rights reserved. All trademarks and registered trademarks are the property of their respective owners. All information and recommendations appearing in this brochure concerning the use of products described herein are based on tests believed to be reliable. However, it is the user's responsibility to determine the suitability for his own use of such products. Since the actual use by others is beyond our control, no guarantee, expressed or implied, is made by Eaton as to the effects of such use or the results to be obtained. Eaton assumes no liability arising out of the use by others of such products. Nor is the information herein to be construed as absolutely complete, since additional information may be necessary or desirable when particular or exceptional conditions or circumstances exist or because of applicable laws or government regulations.