

HYDRAULIC MOTORS MLHS

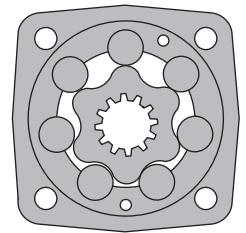

APPLICATION

- » Conveyors
- » Metal working machines
- » Agricultural machines
- » Road building machines
- » Mining machinery
- » Food industries
- » Special vehicles etc.

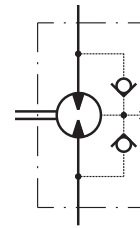

CONTENTS

Specification data	5÷6
Performance data	7÷12
Permissible shaft seal pressure.....	12
Dimensions and mounting	13÷15
Dimensions and mounting - ports	16
Tacho connection	16
Motor with Drum brake- MLHSBD	17
Shaft extensions	18
Permissible shaft loads	19
Function diagram for MLHSBD.....	19
Dimensions and mounting- MLHSS, Z, V, U... ..	20÷21
Dimensions of the attached component	22÷23
Internal Spline data	24
Order code	24

OPTIONS

- » Model - Disc valve, roll-gerotor
- » Flange and wheel mount
- » Short motor
- » Motor with Drum Brake
- » Tacho connection
- » Speed sensing
- » Side and rear ports
- » Shafts- straight, splined and tapered
- » SAE, Metric and BSPP ports
- » Other special features

GENERAL

Max. Displacement, in ³ /rev [cm ³ /rev]	34.47 [564,9]
Max. Speed, [RPM]	1000
Max. Torque, lb-in [daNm]	cont.: 7520 [85] int.: 8760 [99]
Max. Output, HP [kW]	30.8 [23]
Max. Pressure Drop, PSI [bar]	cont.: 3050 [210] int.: 3990 [275]
Max. Oil Flow, GPM [lpm]	24 [90]
Min. Speed, [RPM]	5
Permissible Shaft Loads lbs [daN]	P _a =1125 [500]
Pressure fluid	Mineral based- HLP(DIN 51524) or HM(ISO 6743/4)
Temperature range, °F [°C]	-40÷284 [-40÷140]
Optimal Viscosity range, SUS [mm²/s]	98÷347 [20÷75]
Filtration	ISO code 20/16 (Min. recommended fluid filtration of 25 microns)

Oil flow in drain line

Pressure drop PSI [bar]	Viscosity SUS [mm ² /s]	Oil flow in drain line GPM [lpm]
2030 [140]	98 [20]	.396 [1,5]
	164 [35]	.264 [1]
3045 [210]	98 [20]	.793 [3]
	164 [35]	.528 [2]

Pressure Losses

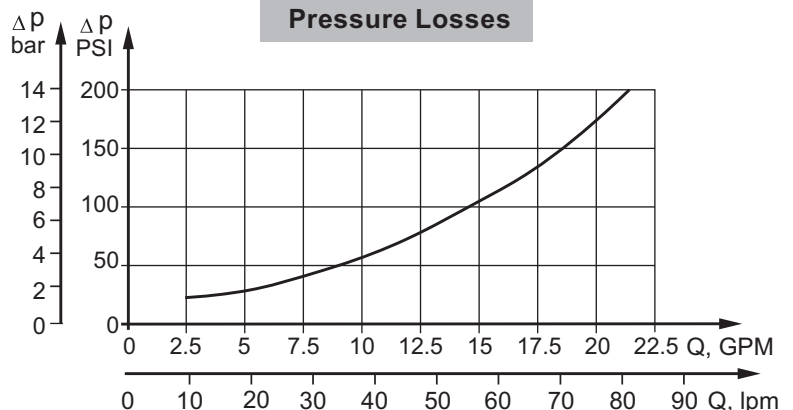

SPECIFICATION DATA

Type		MLHS 80	MLHS 100	MLHS 125	MLHS 160	MLHS 200
Displacement, in³/rev [cm³/rev]		4.91 [80,5]	6.1 [100]	7.67 [125,7]	9.74 [159,7]	12.2 [200]
Max. Speed, [RPM]	cont.	810	750	600	470	375
	Int.*	1000	900	720	560	450
Max. Torque lb-in [daNm]	cont.	2120 [24]	2700 [30,5]	3320 [37,5]	4340 [49]	5400 [61]
	Int.*	2740 [31]	3450 [39]	4340 [49]	5310 [60]	6370 [72]
Max. Output HP [kW]	cont.	20.8 [15,5]	24.1 [18]	24.1 [18]	22.1 [16,5]	22.1 [16,5]
	int.*	26.2 [19,5]	30.2 [22,8]	30.2 [22,5]	30.8 [23]	29.52 [22]
Max. Pressure Drop PSI [bar]	cont.	3050 [210]	3050 [210]	3050 [210]	3050 [210]	3050 [210]
	Int.*	3990 [275]	3990 [275]	3990 [275]	3990 [275]	3990 [275]
	peak**	4280 [295]	4280 [295]	4280 [295]	4280 [295]	4280 [295]
Max. Oil Flow GPM [lpm]	cont.	17 [65]	20 [75]	20 [75]	20 [75]	20 [75]
	Int.*	21 [80]	24 [90]	24 [90]	24 [90]	24 [90]
Max. Inlet Pressure PSI [bar]	cont.	3340 [230]	3340 [230]	3340 [230]	3340 [230]	3340 [230]
	Int.*	4280 [295]	4280 [295]	4280 [295]	4280 [295]	4280 [295]
	peak**	4350 [300]	4350 [300]	4350 [300]	4350 [300]	4350 [300]
Max. Return Pressure with Drain Line PSI [bar]	cont.	2030 [140]	2030 [140]	2030 [140]	2030 [140]	2030 [140]
	Int.*	2540 [175]	2540 [175]	2540 [175]	2540 [175]	2540 [175]
	peak**	3050 [210]	3050 [210]	3050 [210]	3050 [210]	3050 [210]
Max. Starting Pressure with Unloaded Shaft, PSI [bar]		175 [12]	145 [10]	145 [10]	115 [8]	115 [8]
Min. Starting Torque lb-in [daNm]	at max. press. drop cont.	1590 [18]	2040 [23]	2570 [29]	3270 [37]	4160 [47]
	at max. press. drop Int.*	2080 [23,5]	2660 [30]	3360 [38]	4070 [46]	4960 [56]
Min. Speed***, [RPM]		10	10	8	8	6
Weight, lb [kg] For Rear Ports + .88[0,40]	MLHS(F)	21.8 [9,9]	22.2 [10,1]	22.9 [10,4]	23.8 [10,8]	24.7 [11,2]
	MLHSB	22.9 [10,4]	23.3 [10,6]	24 [10,9]	24.6 [11,3]	25.8 [11,7]
	MLHSS(Z)	17.4 [7,9]	17.8 [8,1]	18.5 [8,4]	19.4 [8,8]	20.2 [9,2]
	MLHSV	12.8 [5,8]	13.2 [6]	13.9 [6,3]	14.8 [6,7]	15.6 [7,1]
	MLHSW(E)	22.7 [10,3]	23.2 [10,5]	23.8 [10,8]	24.7 [11,2]	25.6 [11,6]
	MLHSBD	37.3 [16,9]	37.7 [17,1]	38.3 [17,4]	39.2 [17,8]	41.1 [18,2]

* Intermittent operation: the permissible values may occur for max. 10% of every minute.

** Peak load: the permissible values may occur for max. 1% of every minute.

*** For speeds lower than given, consult factory or your regional manager.

1. Intermittent speed and intermittent pressure drop must not occur simultaneously.
2. Recommended filtration is per ISO cleanliness code 20/16. A nominal filtration of 25 micron or better.
3. Recommend using a premium quality, anti-wear type mineral based hydraulic oil HLP(DIN51524) or HM (ISO 6743/4).
If using synthetic fluids consult the factory for alternative seal materials.
4. Recommended minimum oil viscosity 70 SUS [13 mm²/s] at 122°F [50°C].
5. Recommended maximum system operating temperature is 180°F [82°C].
6. To assure optimum motor life fill with fluid prior to loading and run at moderate load and speed for 10-15 minutes.

SPECIFICATION DATA (continued)

Type		MLHS 250	MLHS 315	MLHS 400	MLHS 475	MLHS 525	MLHS 565
Displacement, in³/rev [cm³/rev]		15.3 [250]	19.2 [314,9]	24.2 [397]	28.96[474,6]	31.88 [522,7]	34.47[564,9]
Max. Speed, [RPM]	cont.	300	240	190	160	145	130
	Int.*	360	290	230	190	175	160
Max. Torque lb-in [daNm]	cont.	6370 [72]	7300 [82,5]	7660 [86,5]	7520 [85]	7520 [85]	7520 [85]
	Int.*	7700 [87]	8850 [100]	8760 [99]	8760 [99]	8760 [99]	8760 [99]
Max. Output HP [kW]	cont.	19.4 [14,5]	20.1 [15]	14.8 [11]	11 [8,4]	10.2 [7,6]	9 [6,9]
	int.*	24.1 [18]	22.8 [17]	16.8 [12,5]	15 [11,3]	13.9 [10,4]	13 [9,6]
Max. Pressure Drop PSI [bar]	cont.	2900 [200]	2900 [200]	2320 [160]	1880 [130]	1670 [115]	1520 [105]
	Int.*	3630 [250]	3480 [240]	2760 [190]	2180 [150]	1960 [135]	1810 [125]
	peak**	3920 [270]	3770 [260]	3050 [210]	2470 [170]	2250 [155]	2100 [145]
Max. Oil Flow GPM [lpm]	cont.	20 [75]	20 [75]	20 [75]	20 [75]	20 [75]	20 [75]
	Int.*	24 [90]	24 [90]	24 [90]	24 [90]	24 [90]	24 [90]
Max. Inlet Pressure PSI [bar]	cont.	3340 [230]	3340 [230]	3340 [230]	3340 [230]	3340 [230]	3340 [230]
	Int.*	4280 [295]	4280 [295]	4280 [295]	4280 [295]	4280 [295]	4280 [295]
	peak**	4350 [300]	4350 [300]	4350 [300]	4350 [300]	4350 [300]	4350 [300]
Max. Return Pressure with Drain Line PSI [bar]	cont.	2030 [140]	2030 [140]	2030 [140]	2030 [140]	2030 [140]	2030 [140]
	Int.*	2540 [175]	2540 [175]	2540 [175]	2540 [175]	2540 [175]	2540 [175]
	peak**	3050 [210]	3050 [210]	3050 [210]	3050 [210]	3050 [210]	3050 [210]
Max. Starting Pressure with Unloaded Shaft, PSI [bar]		115 [8]	115 [8]	115 [8]	115 [8]	115 [8]	115 [8]
Min. Starting Torque lb-in [daNm]	at max. press. drop cont.	4960 [56]	6280 [71]	6280 [71]	6280 [71]	6280 [71]	6280 [71]
	at max. press. drop Int.*	6200 [70]	7520 [85]	7430 [84]	7430 [84]	7430 [84]	7430 [84]
Min. Speed***, [RPM]		6	5	5	5	5	5
Weight, lb [kg] For Rear Ports + .88[0,40]	MLHS(F)	25.8 [11,7]	27.3 [12,4]	29.3 [13,1]	31 [14,1]	32.2 [14,6]	33.1 [15]
	MLHSB	26.9 [12,2]	28.4 [12,9]	30.4 [13,8]	32.2 [14,6]	33.3 [15,1]	34.1 [15,5]
	MLHSS(Z)	21.4 [9,7]	22.9 [10,4]	24.9 [11,3]	26.7 [12.1]	27.8 [12,6]	28.6 [13]
	MLHSV	16.7 [7,6]	18.3 [8,3]	20.2 [9,2]	22 [10]	23.1 [10,5]	24 [10,9]
	MLHSW(E)	26.7 [12,1]	28.2 [12,8]	30.2 [13,7]	32 [14,5]	33.1 [15]	33.9 [15,4]
	MLHSBD	41.2 [18,7]	42.7 [19,4]	44.7 [20,3]	46.5 [21,1]	47.6 [21,6]	48.5 [23]

* Intermittent operation: the permissible values may occur for max. 10% of every minute.

** Peak load: the permissible values may occur for max. 1% of every minute.

*** For speeds lower than given, consult factory or your regional manager.

1. Intermittent speed and intermittent pressure drop must not occur simultaneously.
2. Recommended filtration is per ISO cleanliness code 20/16. A nominal filtration of 25 micron or better.
3. Recommend using a premium quality, anti-wear type mineral based hydraulic oil HLP(DIN51524) or HM (ISO 6743/4).
If using synthetic fluids consult the factory for alternative seal materials.
4. Recommended minimum oil viscosity 70 SUS [13 mm²/s] at 122°F [50°C].
5. Recommended maximum system operating temperature is 180°F [82°C].
6. To assure optimum motor life fill with fluid prior to loading and run at moderate load and speed for 10-15 minutes.

FUNCTION DIAGRAMS

MLHS 80

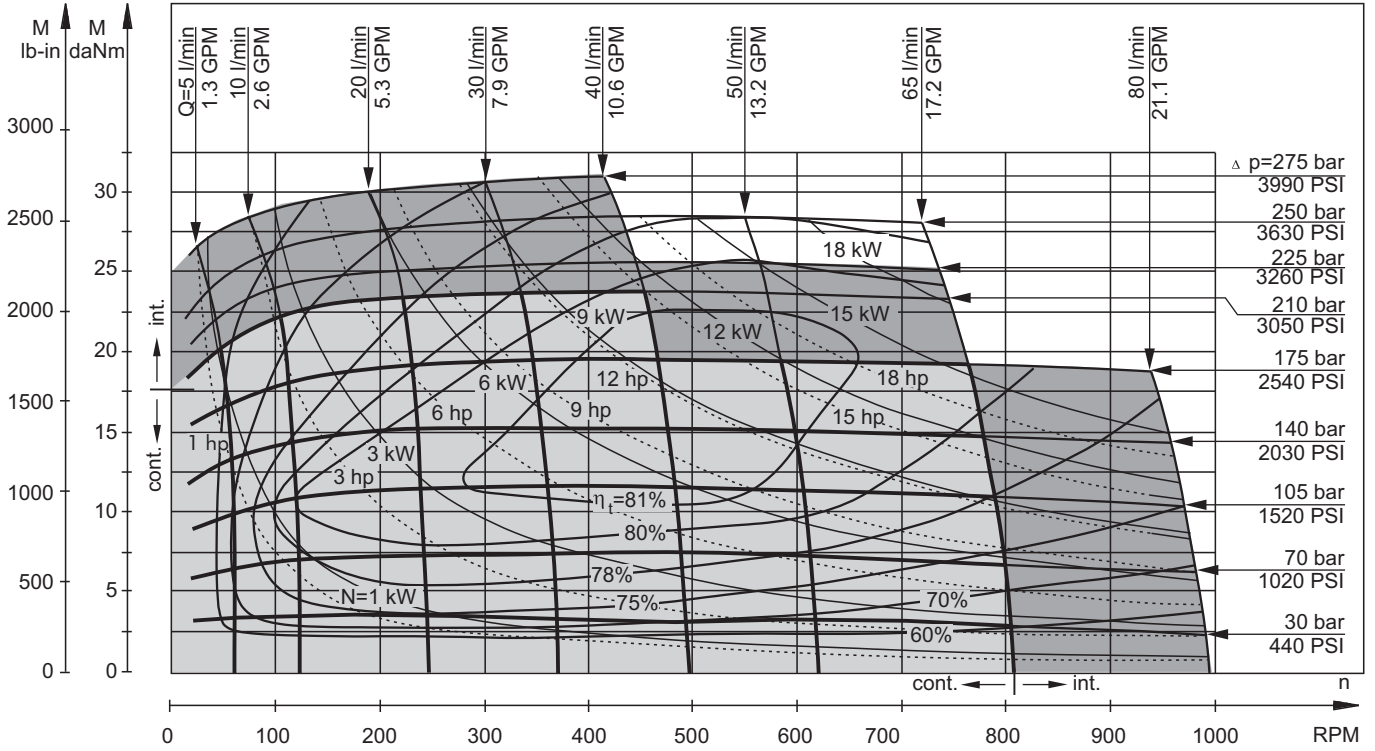

MLHS 100

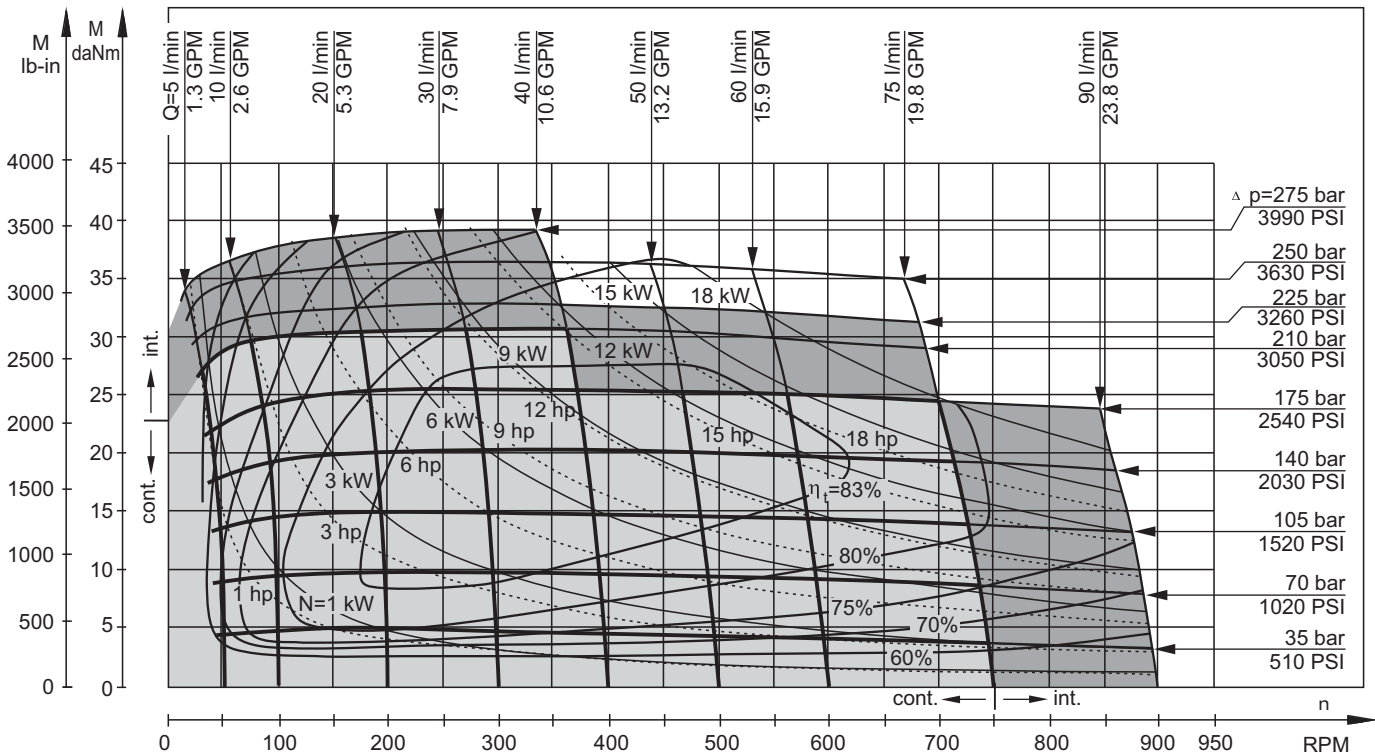

The function diagrams data is for average performance of randomly selected motors at back pressure 5÷10 bar [72.5÷145 PSI] and oil with viscosity of 32 mm²/s [150 SUS] at 50°C [122°F].

FUNCTION DIAGRAMS

MLHS 125

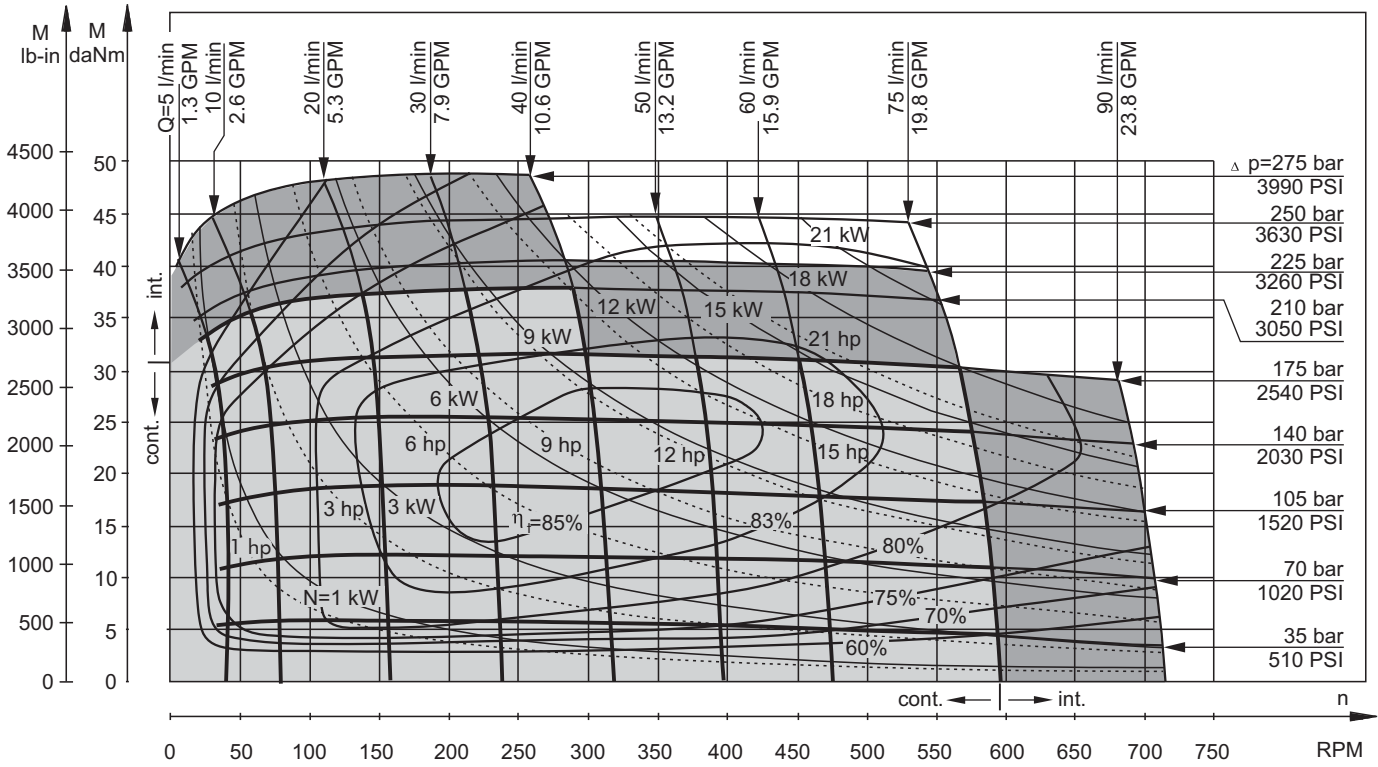

MLHS 160

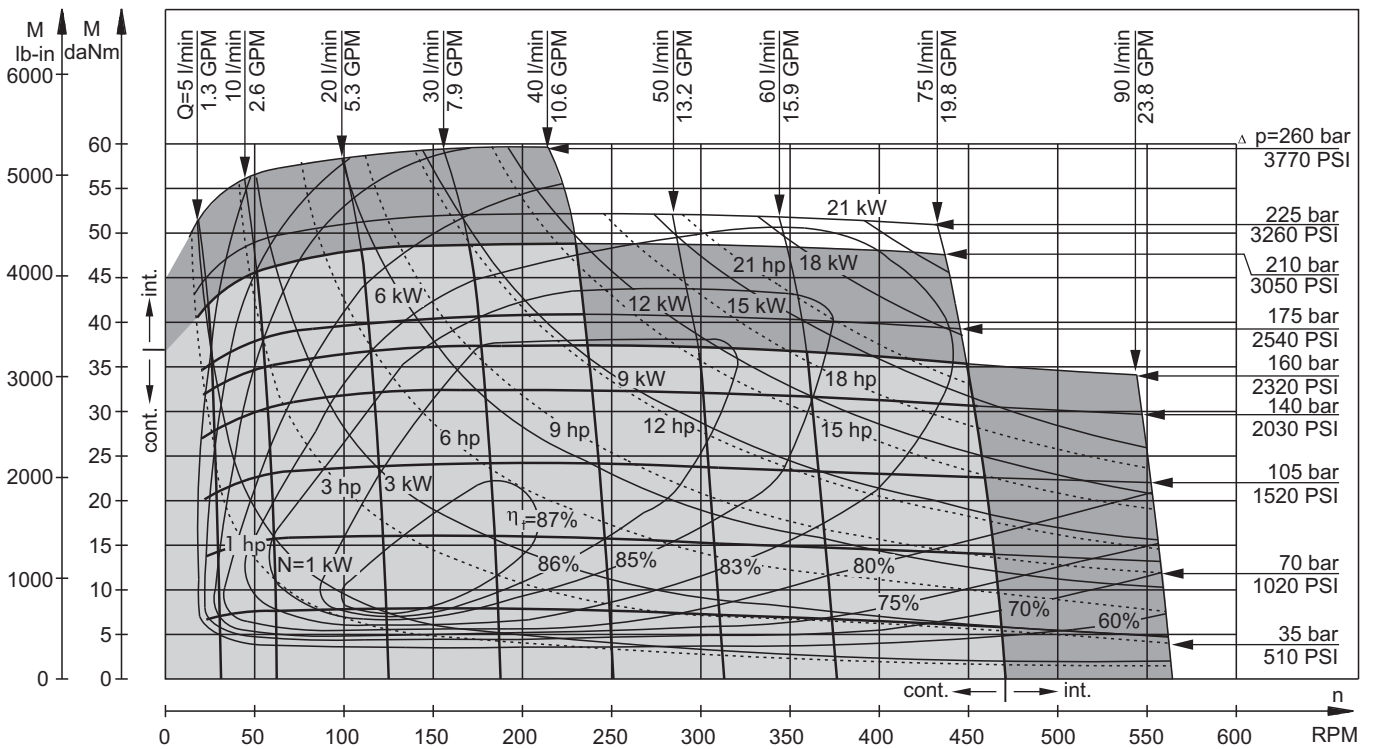

The function diagrams data is for average performance of randomly selected motors at back pressure 5 ± 10 bar [72.5 \pm 145 PSI] and oil with viscosity of 32 mm²/s [150 SUS] at 50°C [122°F].

FUNCTION DIAGRAMS

MLHS 200

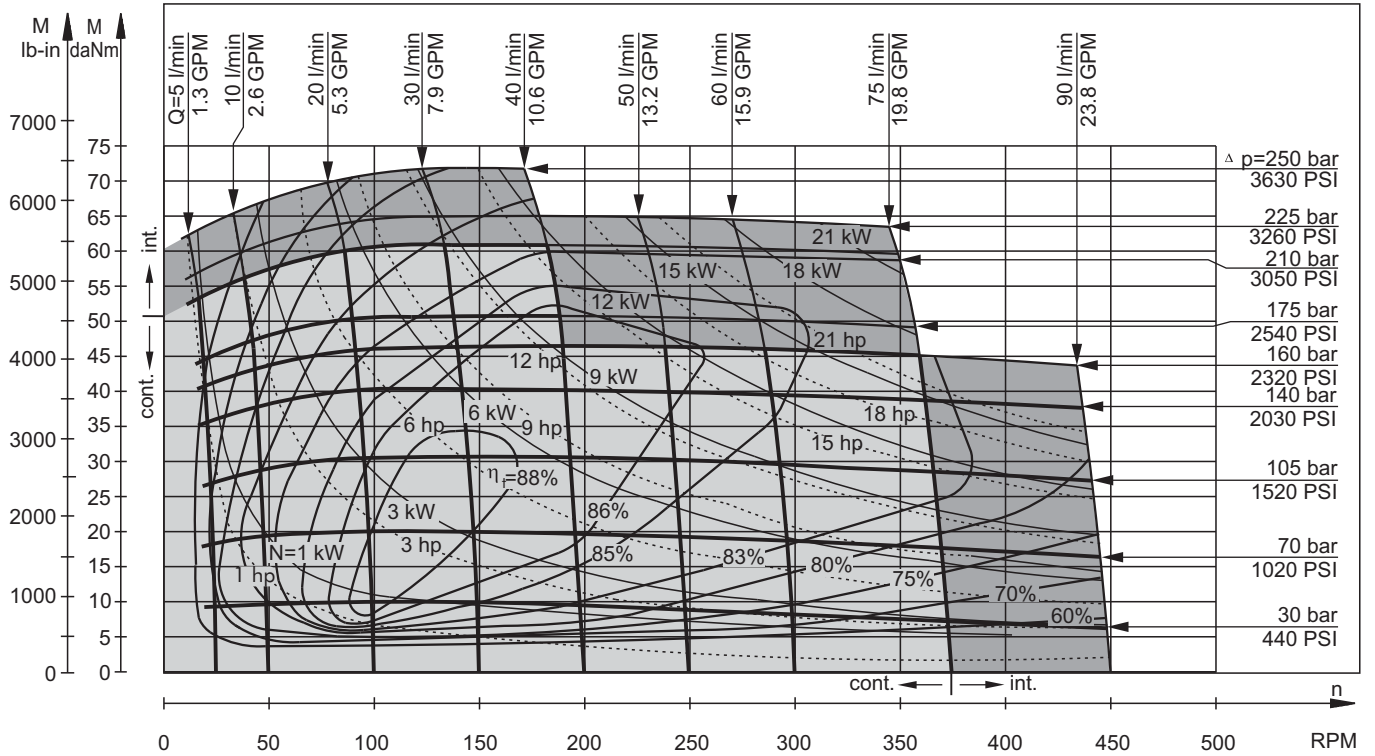

MLHS 250

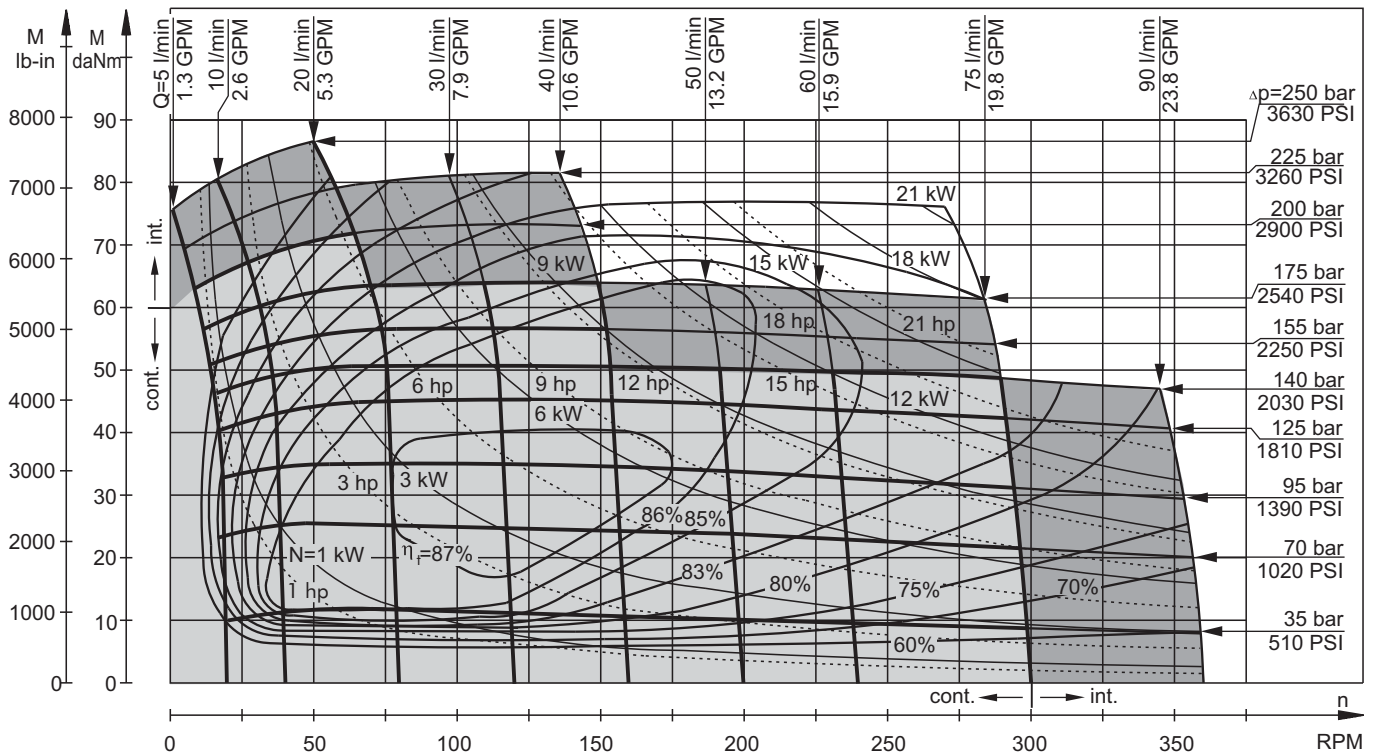

The function diagrams data is for average performance of randomly selected motors at back pressure 5÷10 bar [72.5÷145 PSI] and oil with viscosity of 32 mm²/s [150 SUS] at 50°C [122°F].

FUNCTION DIAGRAMS

MLHS 315

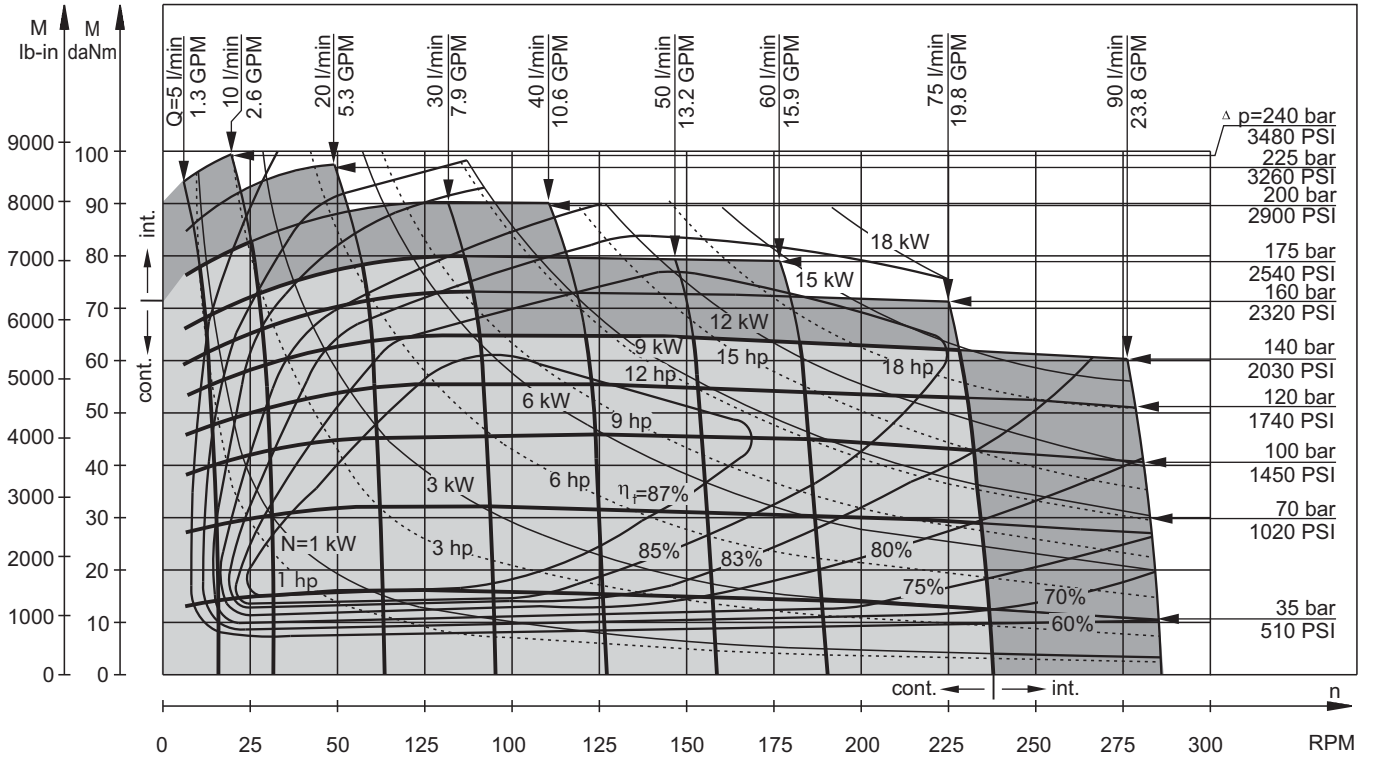

MLHS 400

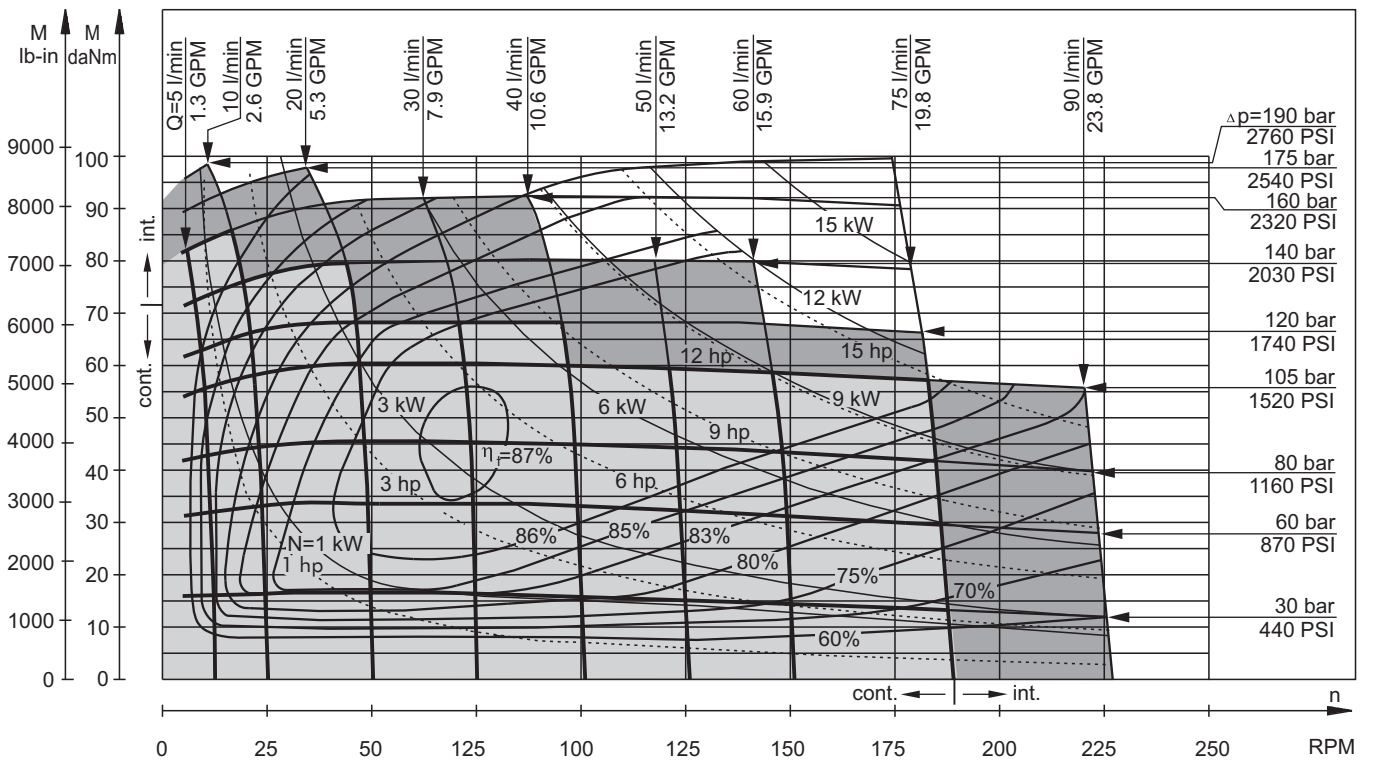

The function diagrams data is for average performance of randomly selected motors at back pressure 5÷10 bar [72.5÷145 PSI] and oil with viscosity of 32 mm²/s [150 SUS] at 50°C [122°F].

FUNCTION DIAGRAMS

MLHS 475

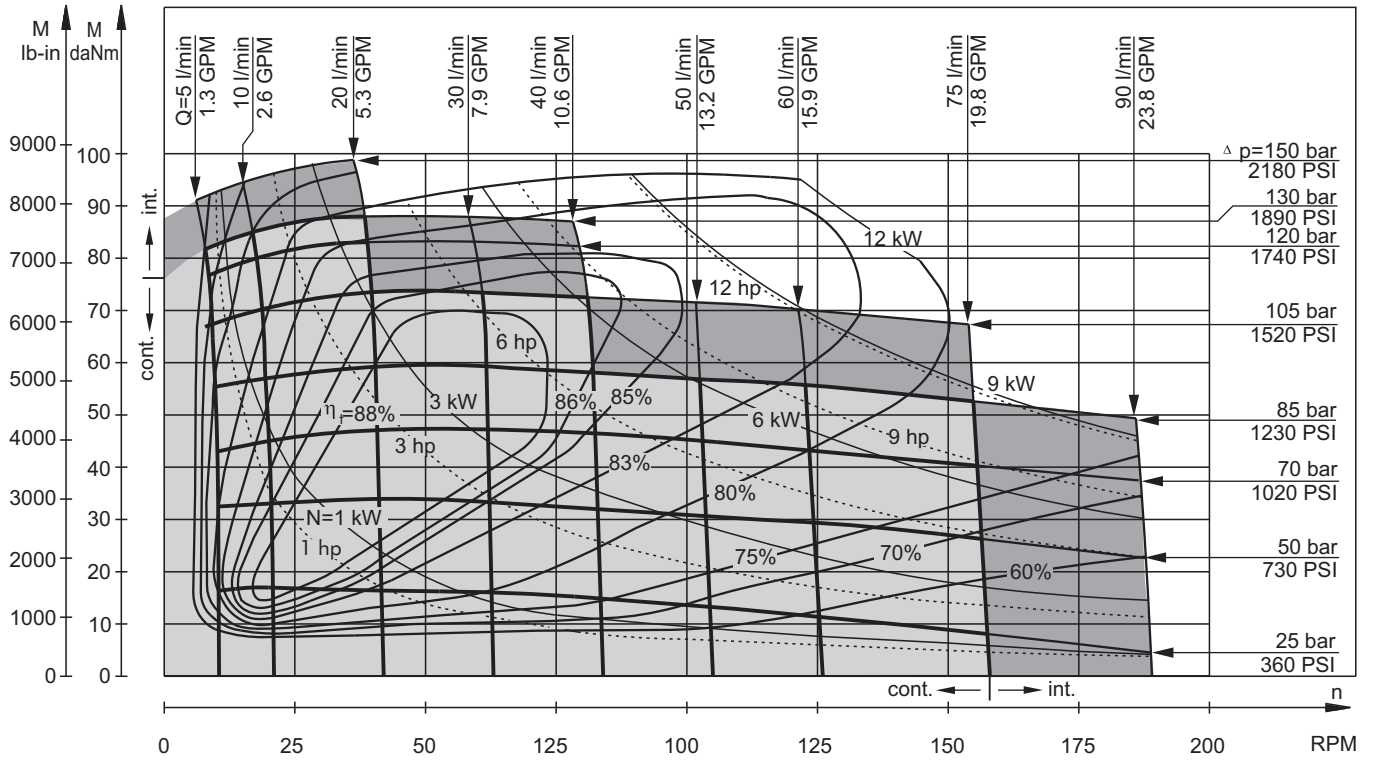

MLHS 525

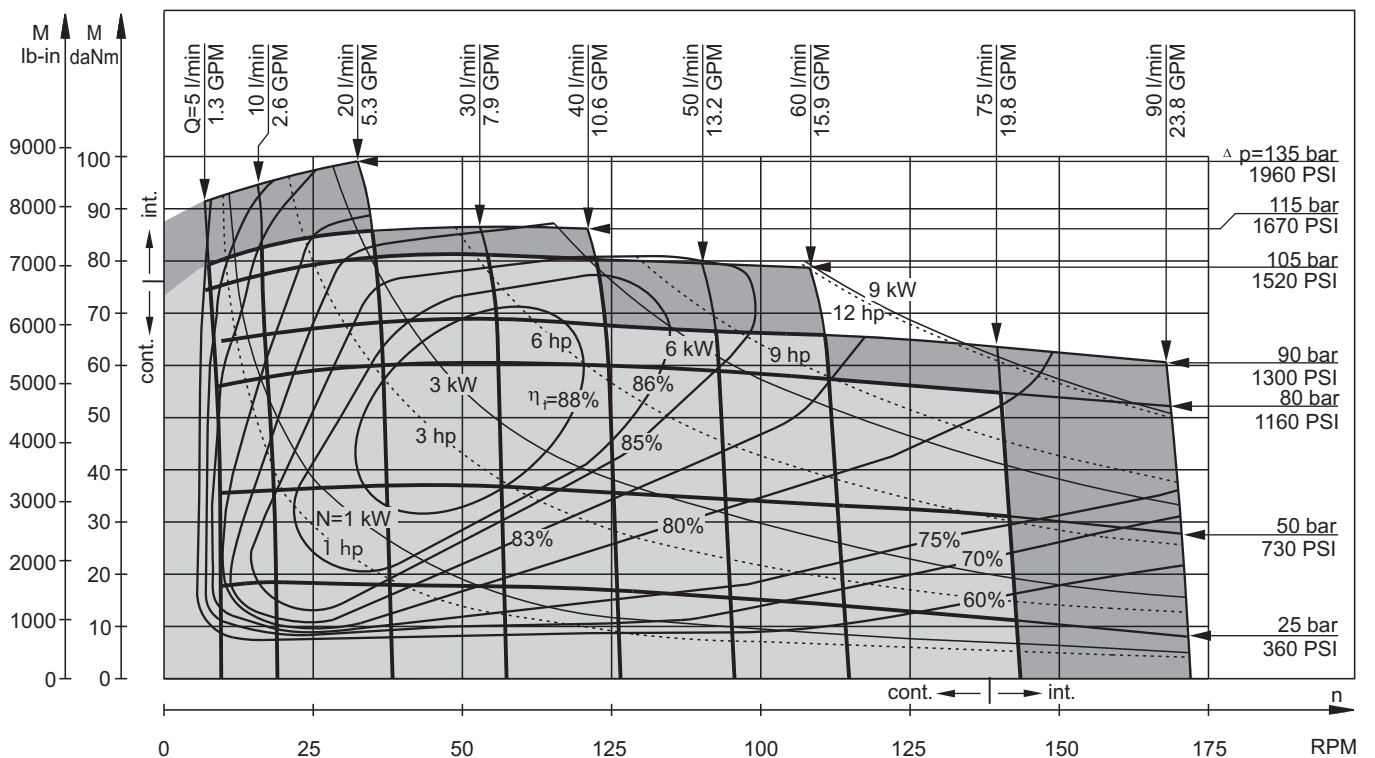

The function diagrams data is for average performance of randomly selected motors at back pressure 5÷10 bar [72.5÷145 PSI] and oil with viscosity of 32 mm²/s [150 SUS] at 50°C [122°F].

FUNCTION DIAGRAMS

MLHS 565

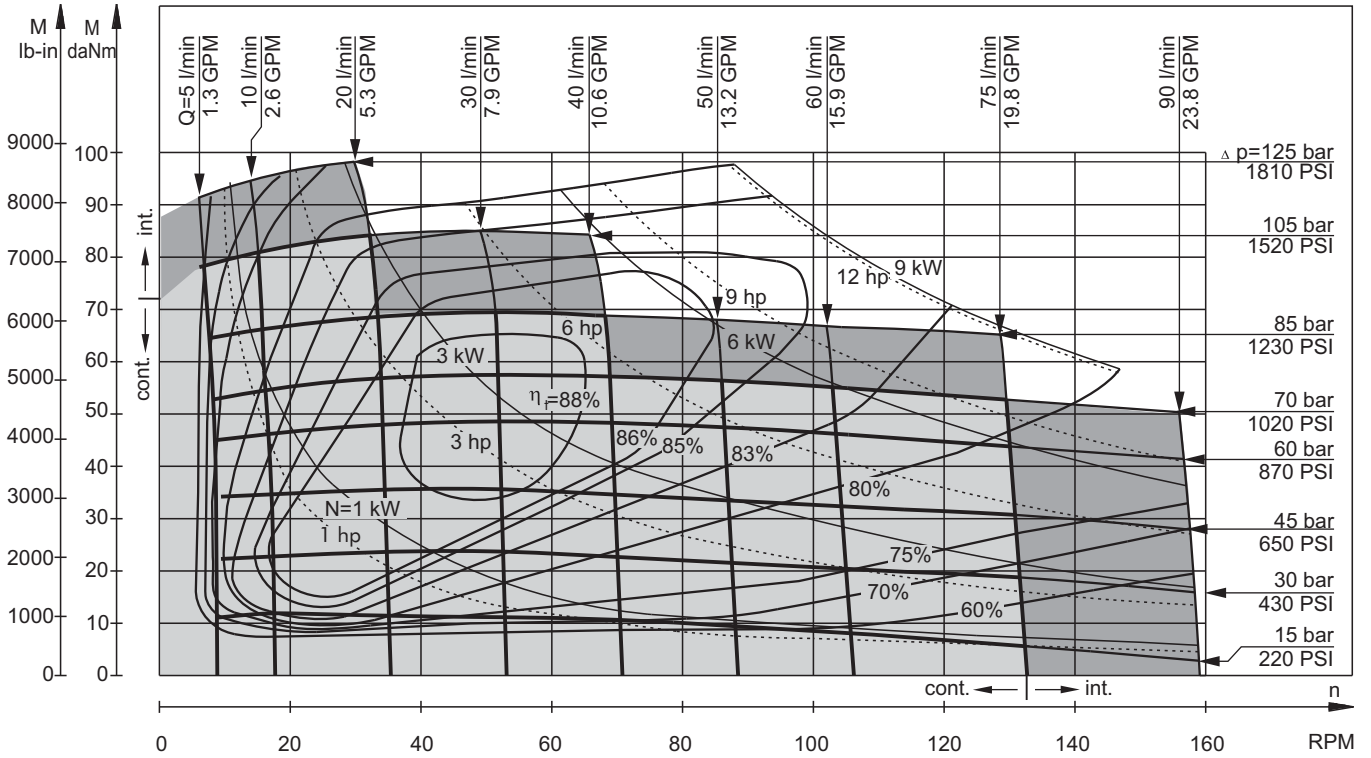

The function diagrams data is for average performance of randomly selected motors at back pressure 5÷10 bar [72.5÷145 PSI] and oil with viscosity of 32 mm²/s [150 SUS] at 50°C [122°F].

MAX. PERMISSIBLE SHAFT SEAL PRESSURE

Max. return pressure without drain line or
max. pressure in the drain line

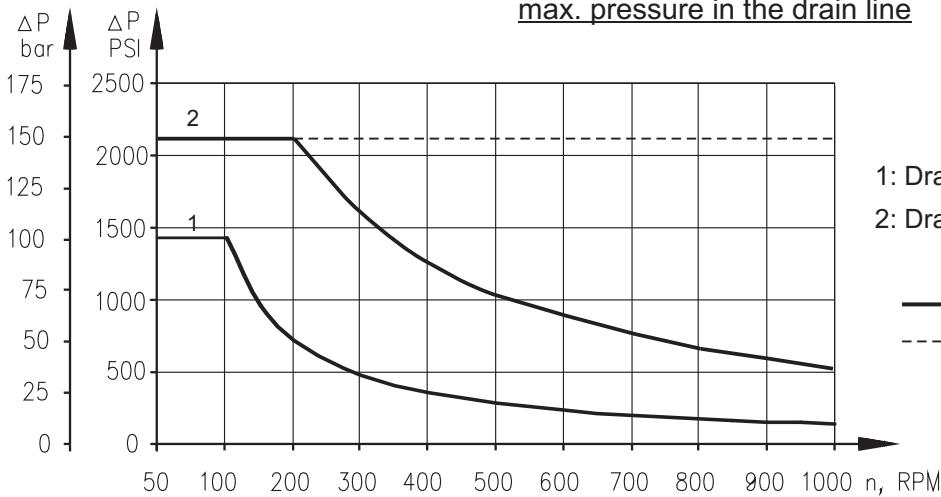

- 1: Drawing for Standard Shaft Seal
- 2: Drawing for High Pressure Seal ("U" Seal)
- - continuous operations
- - - - intermittent operations

DIMENSIONS AND MOUNTING DATA

MLHS, MLHSF, MLHSA

Shaft Dim.
See Page 17

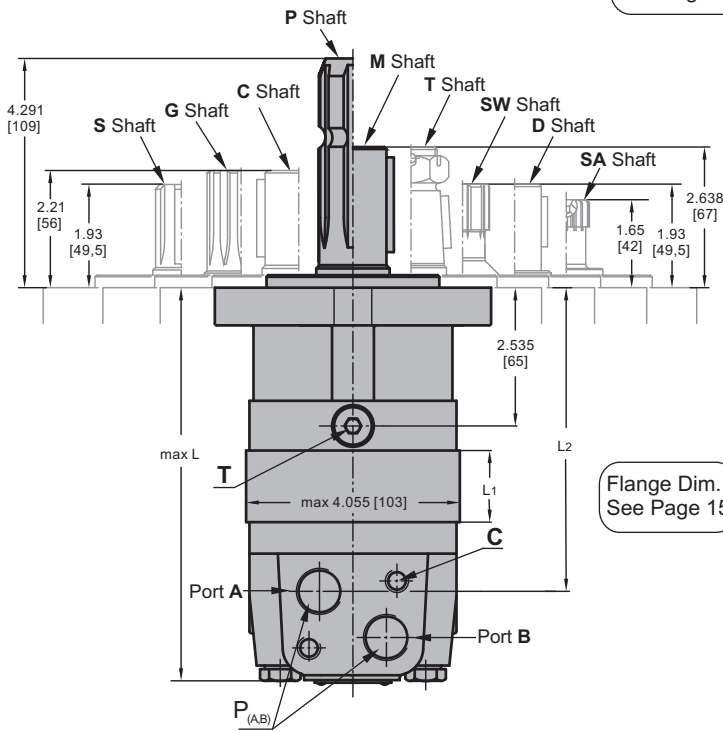

Flange Dim.
See Page 15

MLHSB

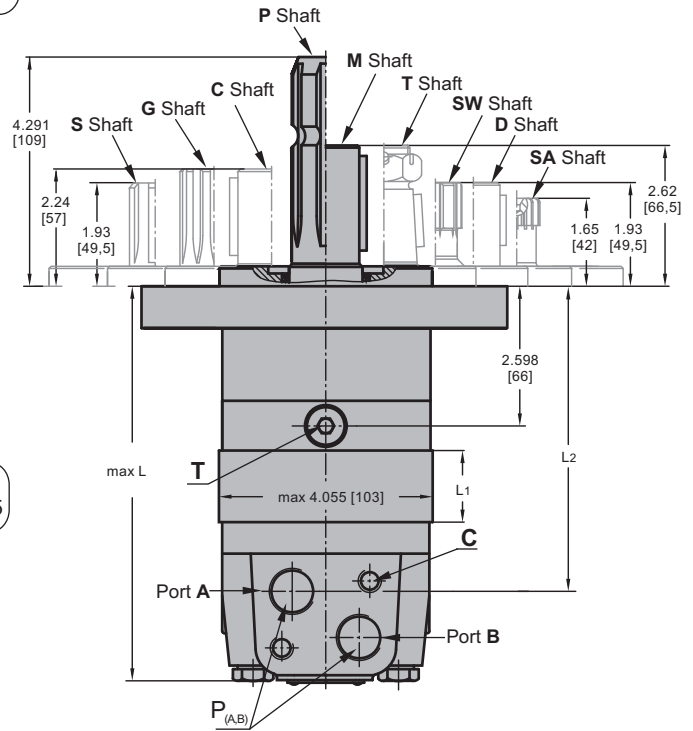

Versions **6 7 8 9**
Rear ports

Port Dim.
See Page 16

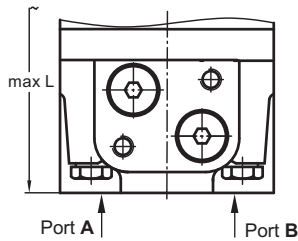

	Versions			
	2,6	3,9	4,7	5,8
C	2xM10	2xM10	2x $\frac{3}{8}$ -16UNC	2x $\frac{3}{8}$ -16UNC
P_(A,B)	2xG $\frac{1}{2}$	2xM22x1,5	2x $\frac{1}{8}$ -14UNF	2x $\frac{1}{2}$ -14NPTF
T	G $\frac{1}{4}$	M14x1,5	$\frac{1}{16}$ -20UNF	$\frac{1}{16}$ -20UNF

Type	L max, in [mm]		L1, in [mm]	L2, in [mm]
	Versions 2,3,4,5	*Versions 6,7,8,9		
MLHS(A,F,B) 80	6.61 [168]	6.89 [175]	.55 [14,0]	4.88 [124]
MLHS(A,F,B) 100	6.73 [171]	7.05 [179]	.69 [17,4]	5.04 [128]
MLHS(A,F,B) 125	6.93 [176]	7.21 [183]	.86 [21,8]	5.20 [132]
MLHS(A,F,B) 160	7.17 [182]	7.44 [189]	1.09 [27,8]	5.43 [138]
MLHS(A,F,B) 200	7.44 [189]	7.72 [196]	1.37 [34,8]	5.71 [145]
MLHS(A,F,B) 250	7.76 [197]	8.07 [205]	1.71 [43,5]	6.06 [154]
MLHS(A,F,B) 315	8.23 [209]	8.50 [216]	2.16 [54,8]	6.50 [165]
MLHS(A,F,B) 400	8.78 [223]	9.05 [230]	2.73 [69,4]	7.05 [179]
MLHS(A,F,B) 475	9.33 [237]	9.61 [244]	3.25 [82,6]	7.60 [193]
MLHS(A,F,B) 525	9.02 [229]	9.29 [236]	2.93 [74,5]	7.28 [185]
MLHS(A,F,B) 565	9.25 [235]	9.53 [242]	3.16 [80,2]	7.52 [191]

* -For Rear Ported Motors.

Standard Rotation
Viewed from Shaft End
Port A Pressurized - **CW**
Port B Pressurized - **CCW**

Reverse Rotation
Viewed from Shaft End
Port A Pressurized - **CCW**
Port B Pressurized - **CW**



DIMENSIONS AND MOUNTING DATA

MLHSW

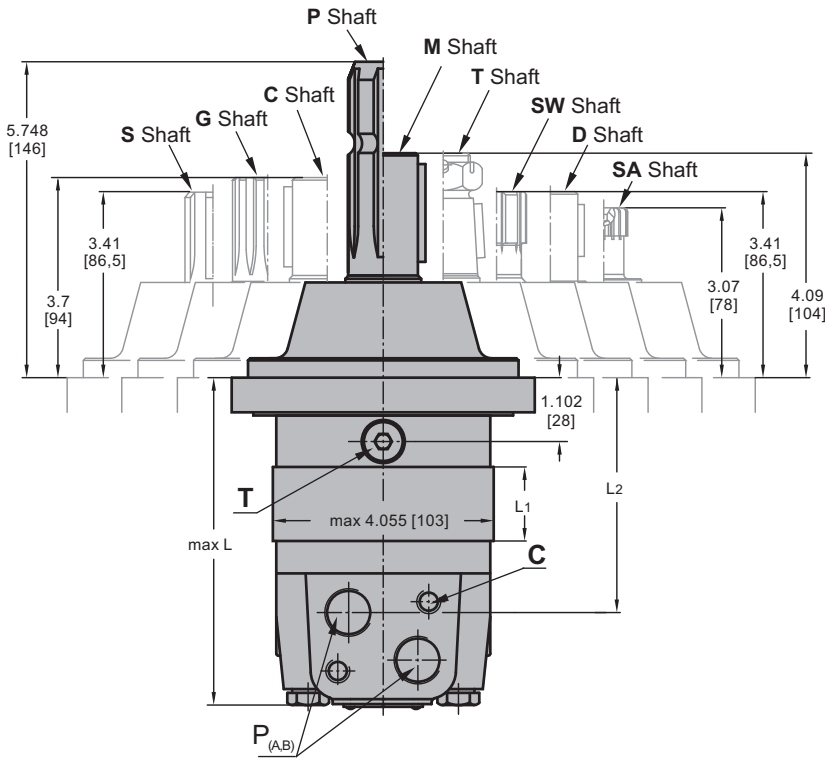

Versions **6 7 8 9**
Rear ports

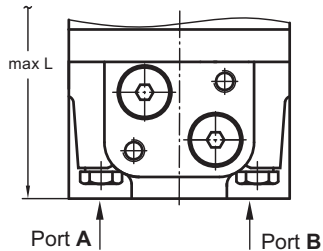

MLHSE

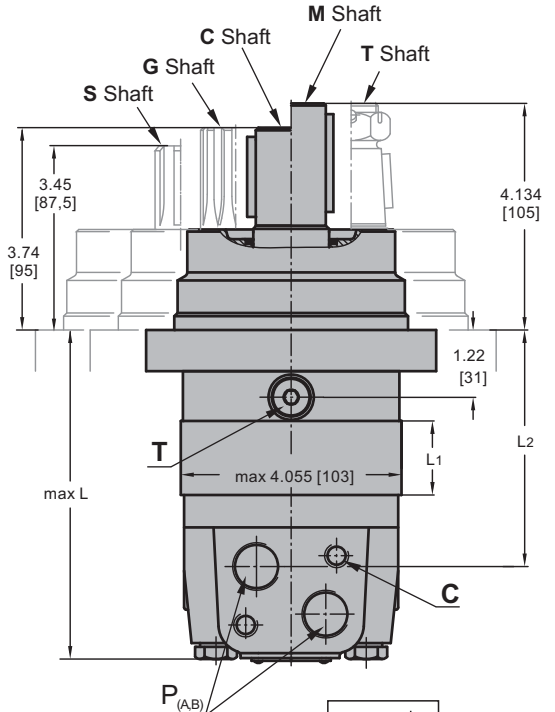

in [mm]

	Versions			
	2,6	3,9	4,7	5,8
C	2xM10	2xM10	2x ³ / ₈ -16UNC	2x ³ / ₈ -16UNC
P_(A,B)	2xG ¹ / ₂	2xM22x1,5	2x ⁷ / ₈ -14UNF	2x ¹ / ₂ -14NPTF
T	G ¹ / ₄	M14x1,5	¹ / ₁₆ -20UNF	¹ / ₁₆ -20UNF

Standard Rotation
Viewed from Shaft End
Port A Pressurized - **CW**
Port B Pressurized - **CCW**

Reverse Rotation
Viewed from Shaft End
Port A Pressurized - **CCW**
Port B Pressurized - **CW**

Type	L max, in [mm]		L2, in [mm]	Type	L max, in [mm]		L2, in [mm]	L1, in [mm]
	Versions 2,3,4,5	*Versions 6,7,8,9			Versions 2,3,4,5	*Versions 6,7,8,9		
MLHSW 80	5.16 [131]	5.43 [138]	3.43 [87]	MLHSE 80	5.24 [133]	5.51 [140]	3.60 [91,5]	.55 [14,0]
MLHSW 100	5.28 [134]	5.59 [142]	3.58 [91]	MLHSE 100	5.39 [137]	5.67 [144]	3.74 [95]	.69 [17,4]
MLHSW 125	5.47 [139]	5.75 [146]	3.74 [95]	MLHSE 125	5.55 [141]	5.83 [148]	3.90 [99]	.86 [21,8]
MLHSW 160	5.71 [145]	5.99 [152]	3.98 [101]	MLHSE 160	5.79 [147]	6.06 [154]	4.13 [105]	1.09 [27,8]
MLHSW 200	5.98 [152]	6.26 [159]	4.25 [108]	MLHSE 200	6.06 [154]	6.34 [161]	4.41 [112]	1.37 [34,8]
MLHSW 250	6.30 [160]	6.62 [168]	4.61 [117]	MLHSE 250	6.42 [163]	6.69 [170]	4.76 [121]	1.71 [43,5]
MLHSW 315	6.73 [171]	7.05 [179]	5.04 [128]	MLHSE 315	6.85 [174]	7.13 [181]	5.20 [132]	2.16 [54,8]
MLHSW 400	7.32 [186]	7.64 [194]	5.63 [143]	MLHSE 400	7.44 [189]	7.72 [196]	5.79 [147]	2.73 [69,4]
MLHSW 475	7.87 [200]	8.15 [207]	6.14 [156]	MLHSE 475	7.95 [202]	8.23 [209]	6.26 [159]	3.25 [82,6]
MLHSW 525	7.56 [192]	7.84 [199]	5.83 [148]	MLHSE 525	7.64 [194]	7.91 [201]	5.95 [151]	2.93 [74,5]
MLHSW 565	7.79 [198]	8.07 [205]	6.06 [154]	MLHSE 565	7.87 [200]	8.15 [207]	6.18 [157]	3.16 [80,2]

* -For Rear Ported Motors.

MOUNTING

SAE A-4 Mount (4 Holes)

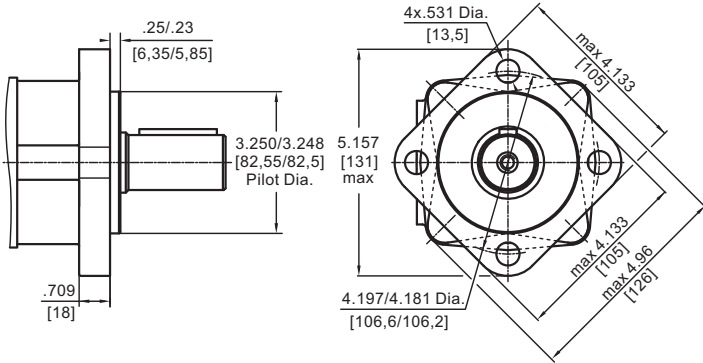

B SAE B Mount (2 Holes)

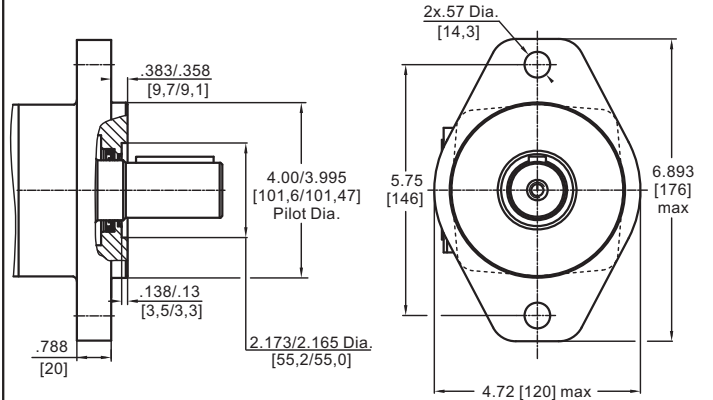

A SAE A-2 Mount (2 Holes)

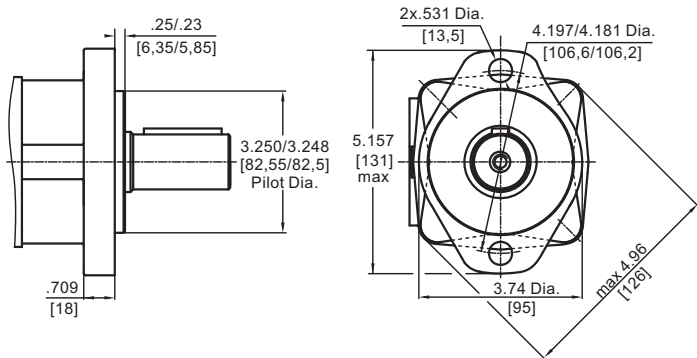

W Wheel Mount

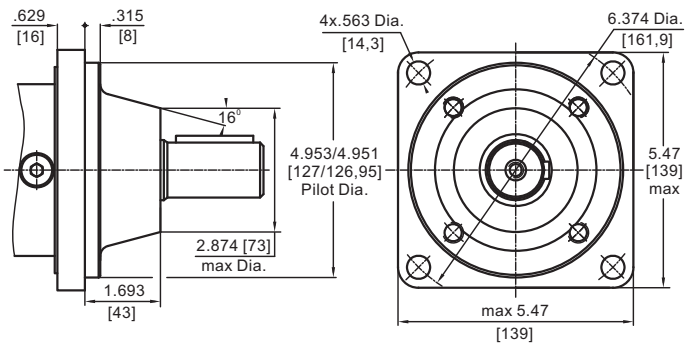

F Magneto Mount (4 Holes)

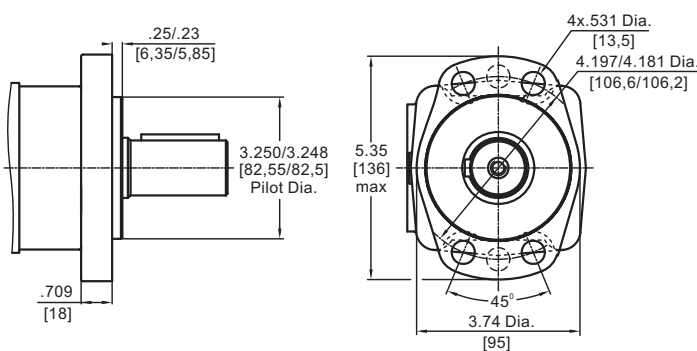

E Wheel Mount

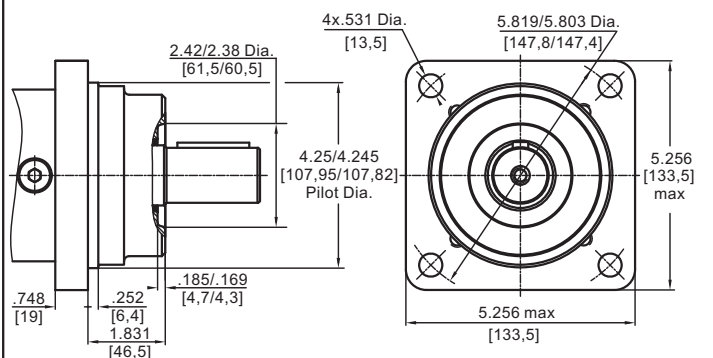

PORTS

Side Ports
Version **2 3 4 5**

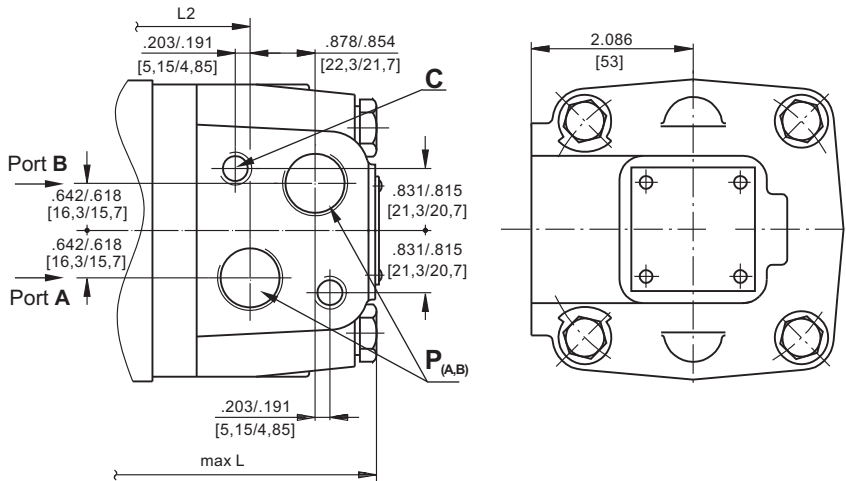

Rear Ports
Version **6 7 8 9**

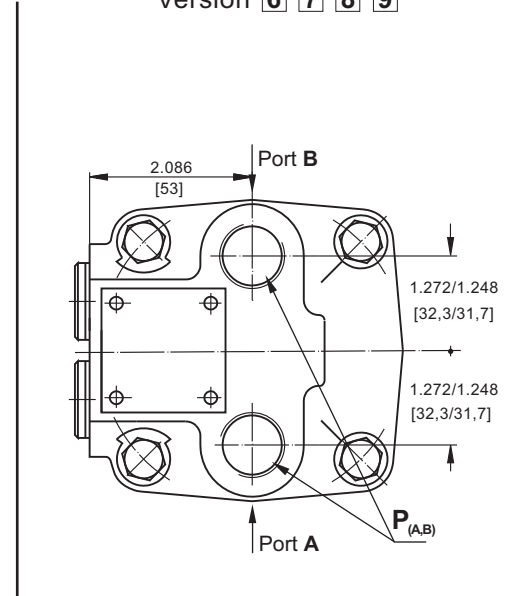

Standard Rotation
Viewed from Shaft End
Port A Pressurized - **CW**
Port B Pressurized - **CCW**

Reverse Rotation
Viewed from Shaft End
Port A Pressurized - **CCW**
Port B Pressurized - **CW**

	Versions			
	2,6	3,9	4,7	5,8
C	2xM10	2xM10	2x $\frac{3}{8}$ -16UNC	2x $\frac{3}{8}$ -16UNC
P_(A,B)	2xG $\frac{1}{2}$	2xM22x1,5	2x $\frac{7}{8}$ -14UNF	2x $\frac{1}{2}$ -14NPTF
T	G $\frac{1}{4}$	M14x1,5	$\frac{7}{16}$ -20UNF	$\frac{7}{16}$ -20UNF

MOTORS WITH TACHO CONNECTION

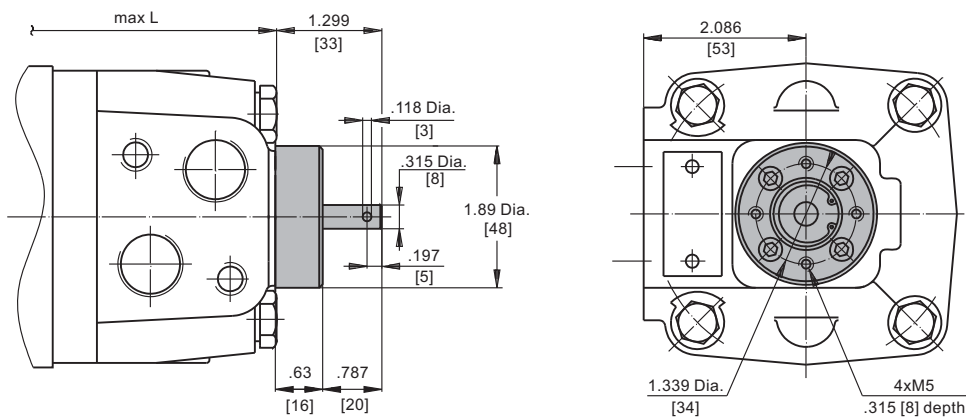

DIMENSIONS AND MOUNTING DATA - MLHSBD (MOTOR WITH DRUM BRAKE)

Actuating the brake level, the brake shaft is turned. The rectangular shape of the inner part of this shaft forces the brake pads to be pressed against the brake drum. This brakes the wheel or the winch drum. Releasing the level, the springs pull it and the brake pads back to the initial position. The motor output shaft is released.

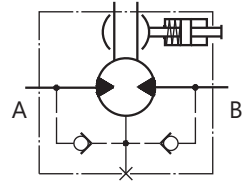

Minimum angle adjustment is 10°. It can be adjusted by dismantling the level. Depending on the application You can choose the actuating direction of the brake level.

The rod connection actuating the brake should be capable of moving at last .975 in [25 mm] from neutral to extreme position.

BD Flange

Versions **2 3 4 5**

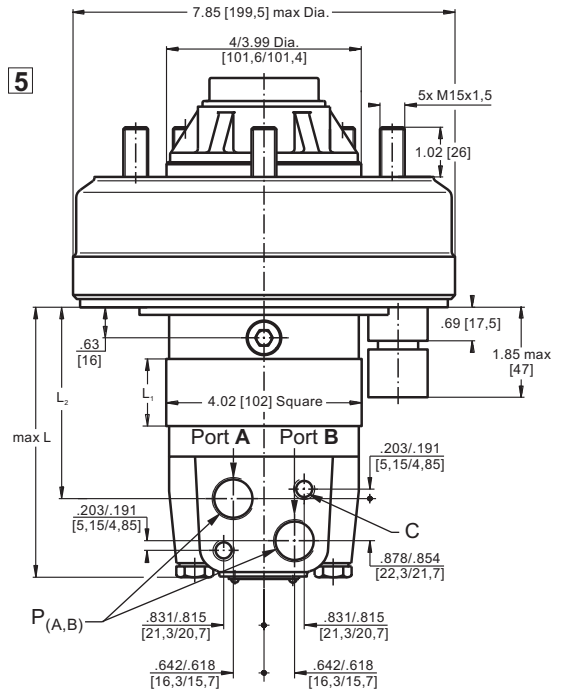
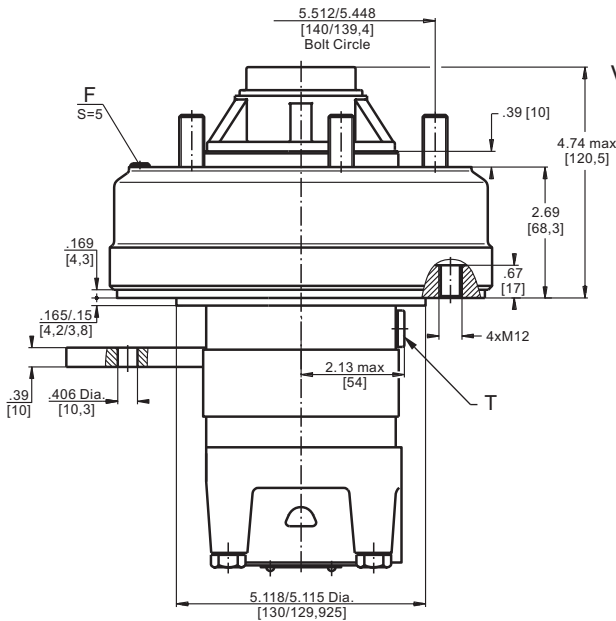

Versions **6 7 8 9**

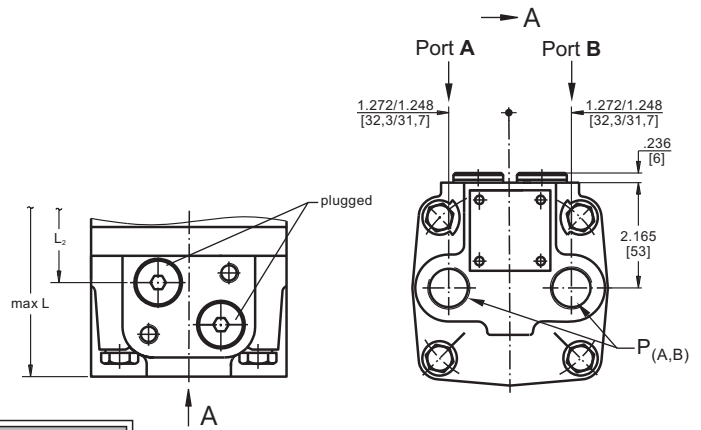
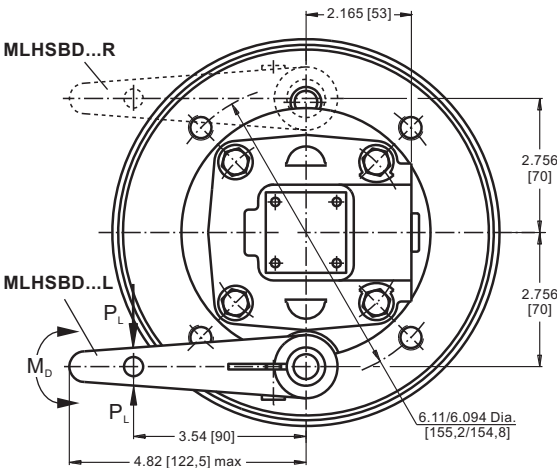

Type	L max, in [mm]		L1, in [mm]	L2, in [mm]
	Versions 2,3,4,5	Versions 6,7,8,9		
MLHSBD 80	4.69 [119]	5.00 [127]	.55 [14,0]	2.91 [74]
MLHSBD 100	4.80 [122]	5.12 [130]	.69 [17,4]	3.03 [77]
MLHSBD 125	4.96 [126]	5.28 [134]	.86 [21,8]	3.23 [82]
MLHSBD 160	5.20 [132]	5.51 [140]	1.09 [27,8]	3.47 [88]
MLHSBD 200	5.47 [139]	5.79 [147]	1.37 [34,8]	3.74 [95]
MLHSBD 250	5.83 [148]	6.14 [156]	1.71 [43,5]	4.33 [110]
MLHSBD 315	6.26 [159]	6.57 [167]	2.16 [54,8]	4.53 [115]
MLHSBD 400	6.85 [174]	7.17 [182]	2.73 [69,4]	5.12 [130]
MLHSBD 475	7.40 [188]	7.72 [196]	3.25 [82,6]	5.63 [143]
MLHSBD 525	7.09 [180]	7.40 [188]	2.93 [74,5]	5.32 [135]
MLHSBD 565	7.32 [186]	7.56 [192]	3.16 [80,2]	5.55 [141]

Standard Rotation
Viewed from Shaft End
Port A Pressurized - CW
Port B Pressurized - CCW

Reverse Rotation
Viewed from Shaft End
Port A Pressurized - CCW
Port B Pressurized - CW

	Versions			
	2,6	3,9	4,7	5,8
C	2xM10	2xM10	2x3/8-16UNC	2x3/8-16UNC
P(A,B)	2xG1/2	2xM22x1,5	2x7/8-14UNF	2x1/2-14NPTF
T	G1/4	M14x1,5	1/16-20UNF	1/16-20UNF
F	Inspection hole for checking brake lining			



SHAFT EXTENSIONS

C

1 1/4" [31,75] straight, Parallel key 5/16"x 5/16"x 1 1/4" BS46
Max. Torque 6815 lb-in [77 daNm]

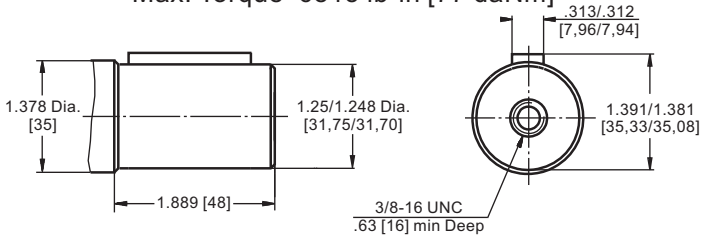

D

1" [25,4] straight, Parallel key 1/4"x 1/4"x 1" BS46
Max. Torque 3900 lb-in [44 daNm]

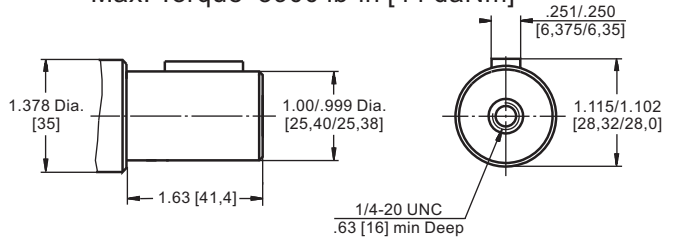

G

14T Splined, 1 1/4" [31,75], ANS B92.1-1976
Max. Torque 8400 lb-in [95 daNm]

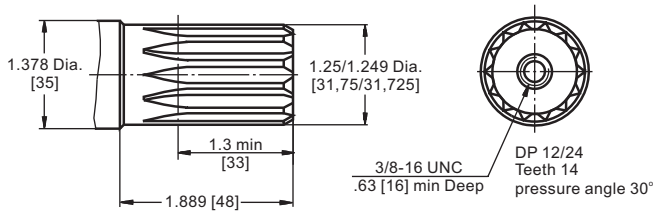

M

ø32 straight, Parallel key A10x8x45 DIN 6885
Max. Torque 6815 lb-in [77 daNm]

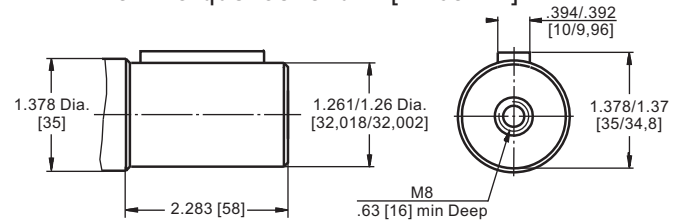

S

1" [25,4], SAE 6B Splined BS2059
Max. Torque 3900 lb-in [44 daNm]

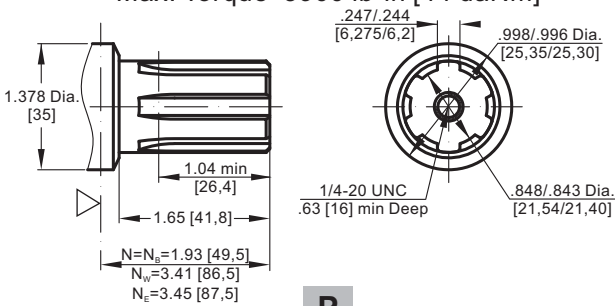

SW

1" [25,4], SAE 6B Splined BS2059
Max. Torque 3400 lb-in [38 daNm]

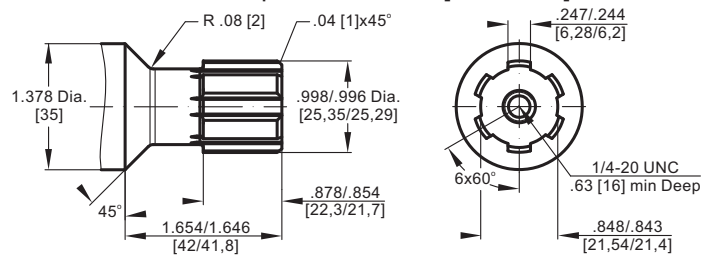

P

ø34,85, p.t.o., DIN 9611 Form 1
Max. Torque 6815 lb-in [77 daNm]

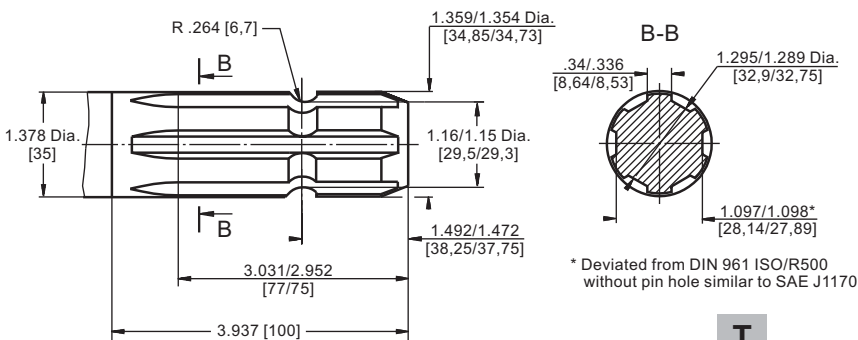

SA

7/8"-13T splined DP16/32 ANS B92.1-1970
Max. Torque 1770 lb-in [20 daNm]

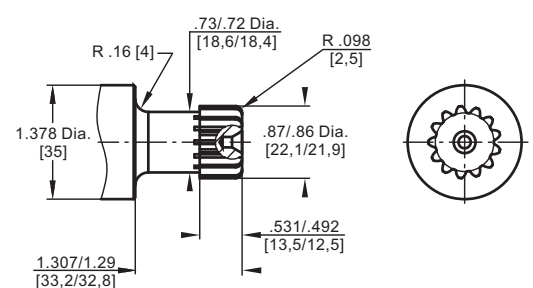

T

1 1/4" [31,75] SAE J501 Tapered, Parallel key 5/16"x 5/16"x 1" BS46
Max. Torque 8400 lb-in [95 daNm]

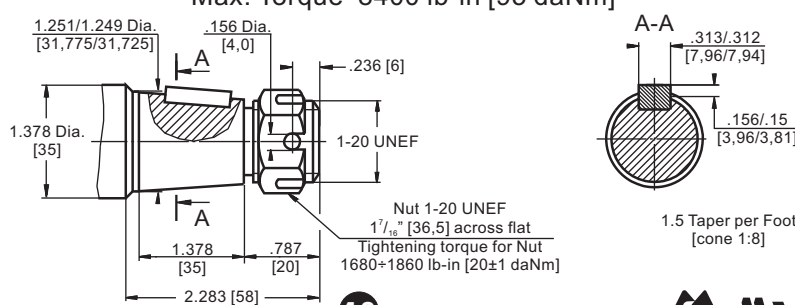

Requirement max. Torque must not be exceeded.



PERMISSIBLE SHAFT LOADS

The output shaft runs in tapered bearings that permit high axial and radial forces. The permissible radial load on the shaft is shown for an axial load of 0 N as function of the distance from the mounting flange to the point of load application. The curves apply to a B10 bearing life of 2000 hours at 100 RPM .

Curve "1" shows max. radial shaft load. Any shaft load exceeding the values shown by the curve will seriously reduce motor life.

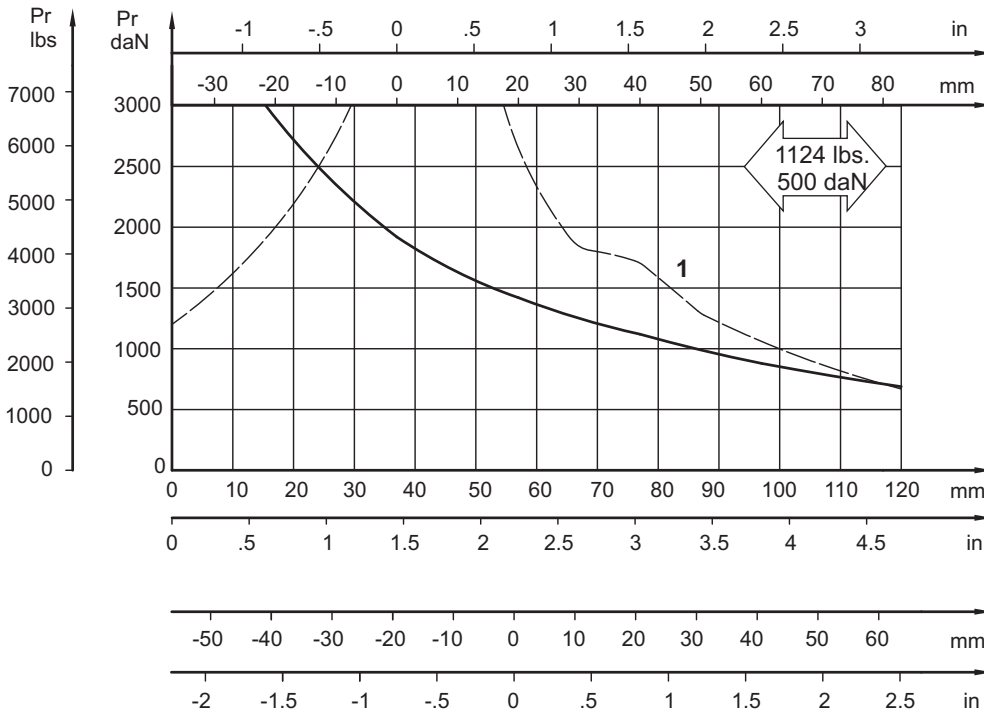

Mounting Flange:

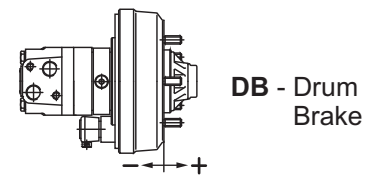
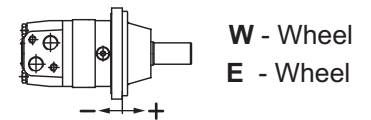
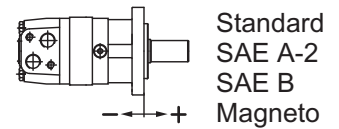

Shaft: All type shafts except SA

FUNCTION DIAGRAM MLHSBD

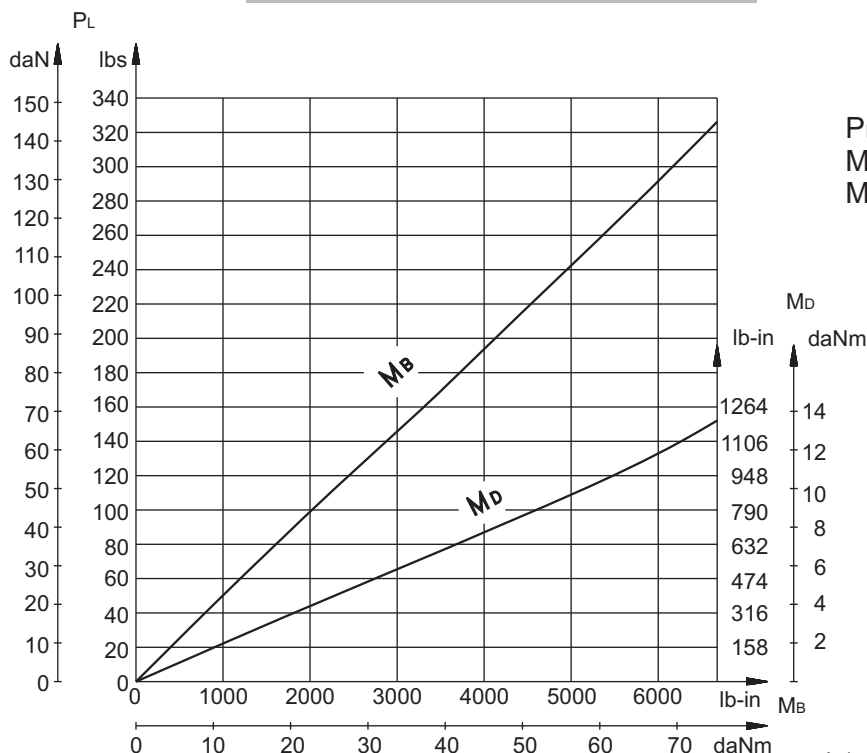

PL - Brake Lever Load
Mb - Brake Torque
Md - Brake Lever Torque

DIMENSIONS AND MOUNTING DATA - MLHSS and MLHSZ

S Short Mount

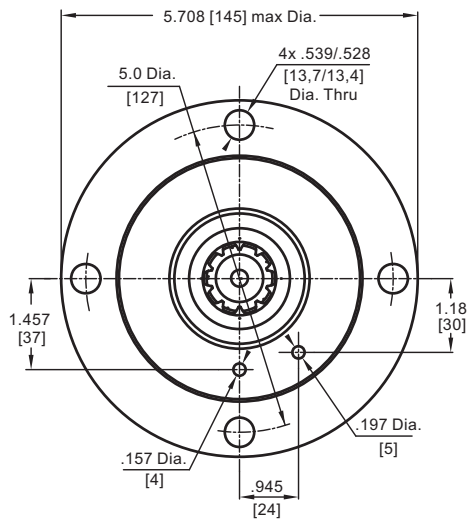

**Z Short Mount
(with place for needle bearing)**

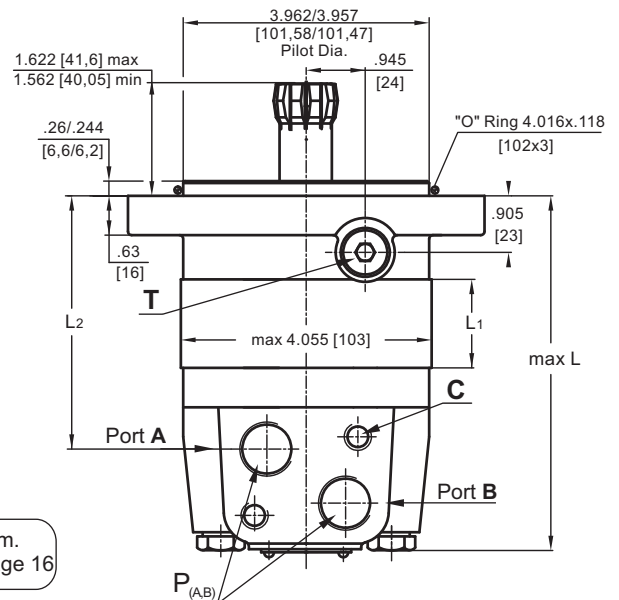
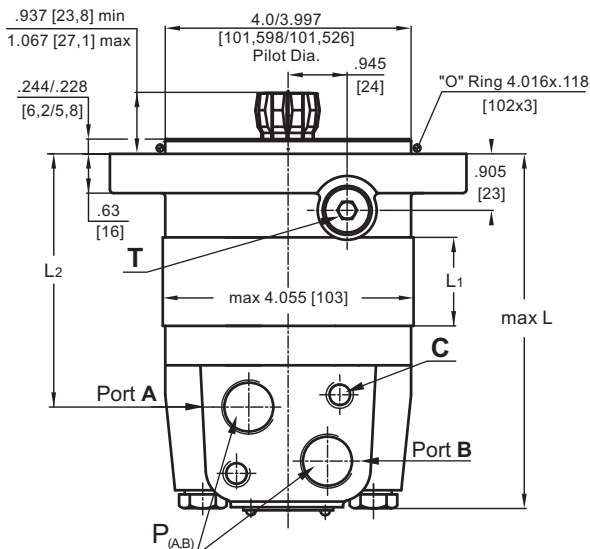
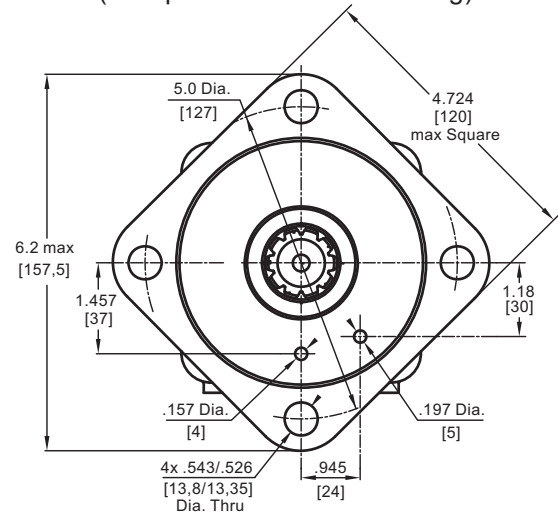

Port Dim.
See Page 16

Versions **6 7 8 9**

Rear ports

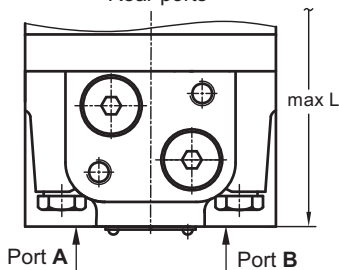

Standard Rotation

Viewed from Shaft End
Port A Pressurized - **CW**
Port B Pressurized - **CCW**

Reverse Rotation

Viewed from Shaft End
Port A Pressurized - **CCW**
Port B Pressurized - **CW**

		Versions			
		2,6	3,9	4,7	5,8
C	2xM10	2xM10	2x $\frac{3}{8}$ -16UNC	2x $\frac{3}{8}$ -16UNC	
P_(A,B)	2xG $\frac{1}{2}$	2xM22x1,5	2x $\frac{7}{8}$ -14UNF	2x $\frac{1}{2}$ -14NPTF	
T	G $\frac{1}{4}$	M14x1,5	$\frac{7}{16}$ -20UNF	$\frac{7}{16}$ -20UNF	

Type	L max, in [mm]		L1, in [mm]	L2, in [mm]
	Versions 2,3,4,5	*Versions 6,7,8,9		
MLHSS(Z) 80	4.92 [125]	5.28 [134]	.55 [14,0]	3.27 [83]
MLHSS(Z) 100	5.08 [129]	5.43 [138]	.69 [17,4]	3.43 [87]
MLHSS(Z) 125	5.24 [133]	5.55 [141]	.86 [21,8]	3.54 [90]
MLHSS(Z) 160	5.47 [139]	5.79 [147]	1.09 [27,8]	3.78 [96]
MLHSS(Z) 200	5.75 [146]	6.06 [154]	1.37 [34,8]	4.05 [103]
MLHSS(Z) 250	6.10 [155]	6.42 [163]	1.71 [43,5]	4.41 [112]
MLHSS(Z) 315	6.54 [166]	6.85 [174]	2.16 [54,8]	4.84 [123]
MLHSS(Z) 400	7.13 [181]	7.44 [189]	2.73 [69,4]	5.43 [138]
MLHSS(Z) 475	7.64 [194]	7.99 [203]	3.25 [82,6]	5.98 [152]
MLHSS(Z) 525	7.32 [186]	7.68 [195]	2.93 [74,5]	5.67 [144]
MLHSS(Z) 565	7.56 [192]	7.91 [201]	3.16 [80,2]	5.91 [150]

* -For Rear Ported Motors.

DIMENSIONS AND MOUNTING DATA - MLHSV and MLHSU

V Very Short Mount

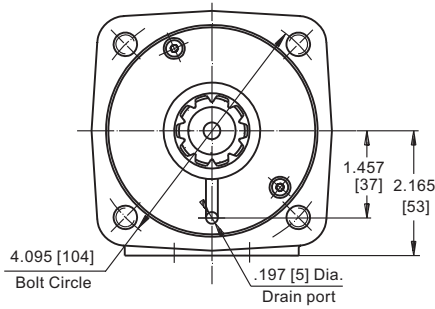

U Ultra Short Mount

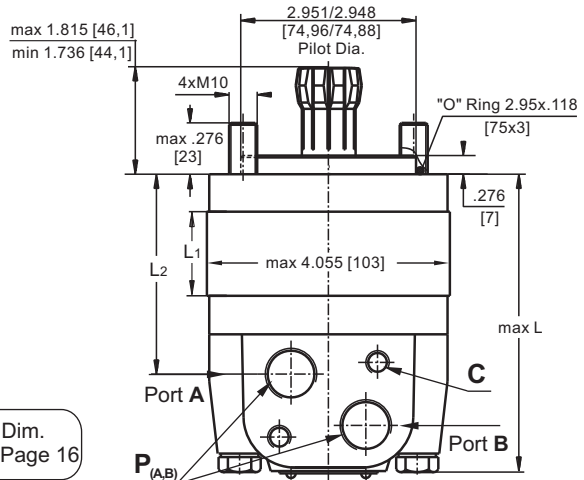
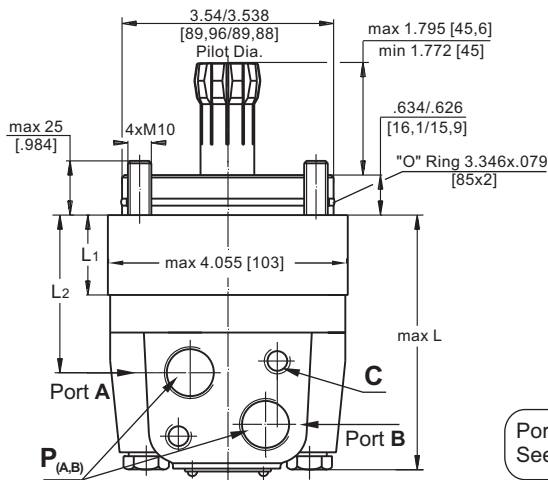
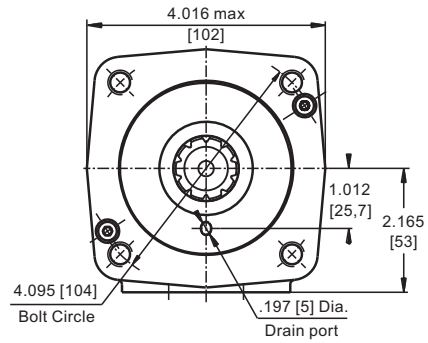

Port Dim.
See Page 16

Versions **6 7 8 9**

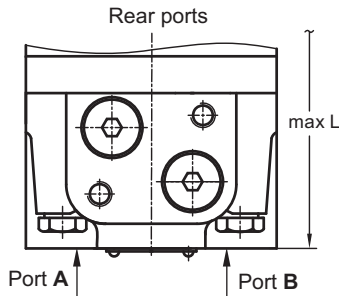

Standard Rotation

Viewed from Shaft End
Port A Pressurized - CW
Port B Pressurized - CCW

Reverse Rotation

Viewed from Shaft End
Port A Pressurized - CCW
Port B Pressurized - CW

	Versions			
	2,6	3,9	4,7	5,8
C	2xM10	2xM10	2x $\frac{3}{8}$ -16UNC	2x $\frac{3}{8}$ -16UNC
P(A,B)	2xG $\frac{1}{2}$	2xM22x1,5	2x $\frac{7}{8}$ -14UNF	2x $\frac{1}{2}$ -14NPTF

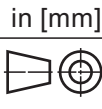

Type	L max, in [mm]		L2, in [mm]	Type	L max, in [mm]		L2, in [mm]	L1, in [mm]
	Versions 2,3,4,5	*Versions 6,7,8,9			Versions 2,3,4,5	*Versions 6,7,8,9		
MLHSV 80	3.58 [91]	3.82 [97]	1.85 [47]	MLHSU 80	4.15 [105,5]	4.39 [111,5]	2.48 [63]	.55 [14,0]
MLHSV 100	3.70 [94]	3.94 [100]	1.99 [50,5]	MLHSU 100	4.29 [109]	4.53 [115]	2.62 [66,5]	.69 [17,4]
MLHSV 125	3.90 [99]	4.13 [105]	2.17 [55]	MLHSU 125	4.45 [113]	4.69 [119]	2.80 [71]	.86 [21,8]
MLHSV 160	4.13 [105]	4.37 [111]	2.40 [61]	MLHSU 160	4.69 [119]	4.92 [125]	3.03 [77]	1.09 [27,8]
MLHSV 200	4.41 [112]	4.64 [118]	2.78 [68]	MLHSU 200	4.96 [126]	5.20 [132]	3.31 [84]	1.37 [34,8]
MLHSV 250	4.72 [120]	4.96 [126]	3.01 [76,5]	MLHSU 250	5.32 [135]	5.55 [141]	3.64 [92,5]	1.71 [43,5]
MLHSV 315	5.20 [132]	5.43 [138]	3.46 [88]	MLHSU 315	5.75 [146]	5.98 [152]	4.09 [104]	2.16 [54,8]
MLHSV 400	5.75 [146]	6.02 [153]	4.05 [103]	MLHSU 400	6.30 [160]	6.58 [167]	4.69 [119]	2.73 [69,4]
MLHSV 475	6.30 [160]	6.54 [166]	4.57 [116]	MLHSU 475	6.85 [174]	7.09 [180]	5.20 [132]	3.25 [82,6]
MLHSV 525	5.98 [152]	6.22 [158]	4.25 [108]	MLHSU 525	6.54 [166]	6.77 [172]	4.88 [124]	2.93 [74,5]
MLHSV 565	6.22 [158]	6.46 [164]	4.49 [114]	MLHSU 565	6.77 [172]	7.01 [178]	5.12 [130]	3.16 [80,2]

* -For Rear Ported Motors.

DIMENSIONS OF THE ATTACHED COMPONENT

For MLHSS

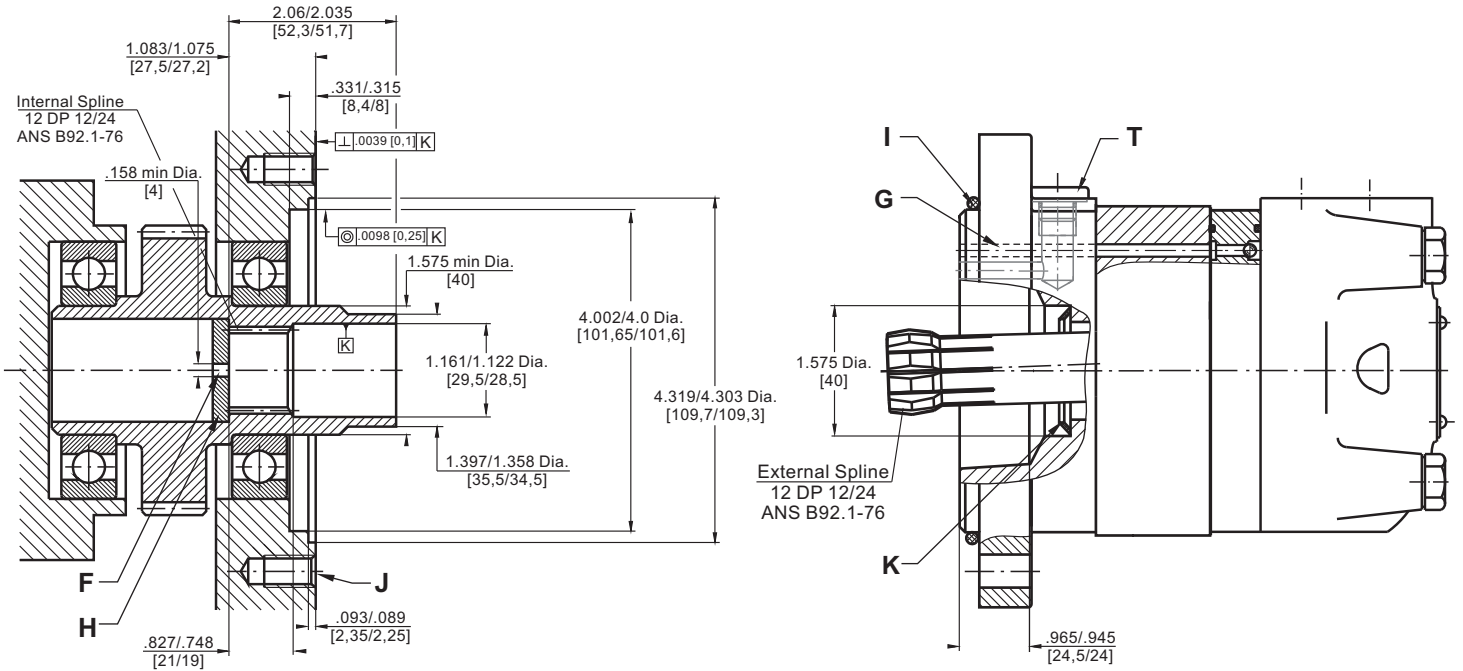

For MLHSZ

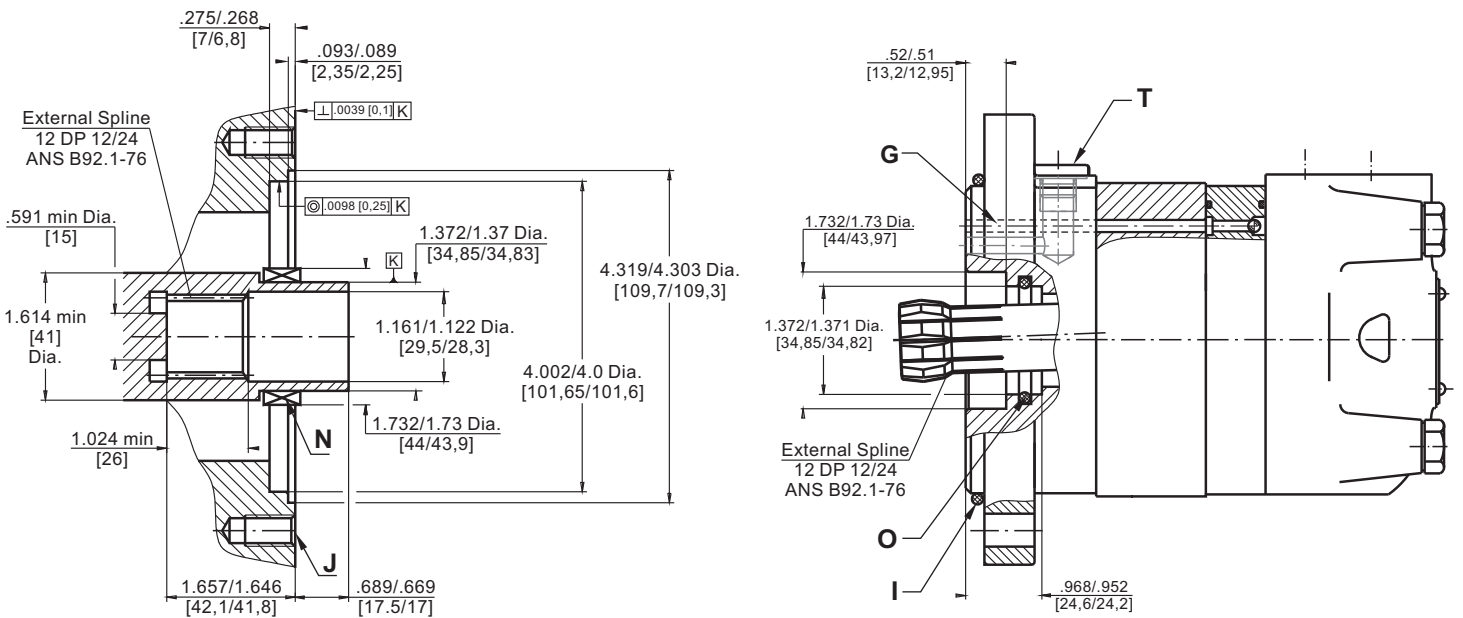

- F: Oil circulation hole
- H: Hardened stop plate
- I: "O"- Ring 4.016x .118 [102x3]
- K: Conical seal ring

- G: Internal drain channel
- J: 4x½ UN- min .61 [15] Deep, 90°, 5.00[127] Dia. B.C.
- N: Needle bearing 1⅜"x 1¾"
- O: "O"- Ring 1.358x .104 [34,5x2,65]
- T: Drain connection G1/4, M14x1,5 or ⅞-20UNF

DIMENSIONS OF THE ATTACHED COMPONENT (continued)

For MLHSV

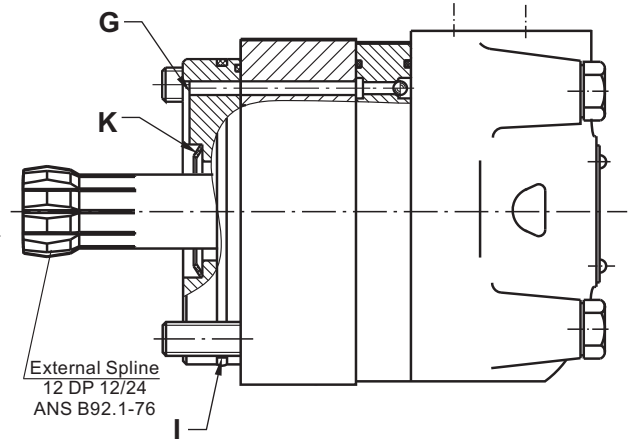
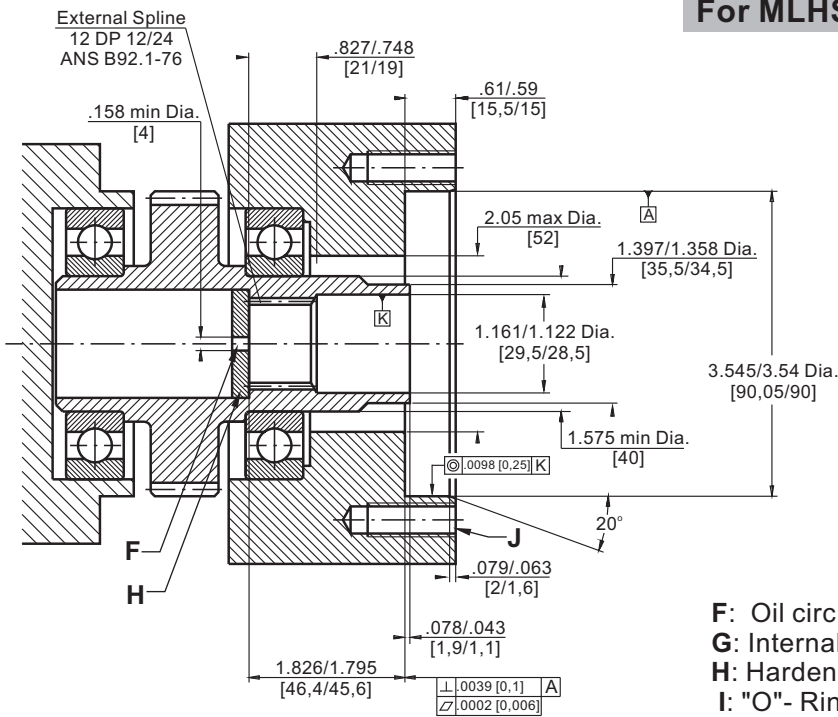

- F: Oil circulation hole
- G: Internal drain channel
- H: Hardened stop plate
- I: "O"- Ring 3.346x .079 [85x2]
- J: 4xM10- min 1.024 [26] Deep, 90°, 4.095[104] Dia. B.C.
- K: Conical seal ring

For MLHSU

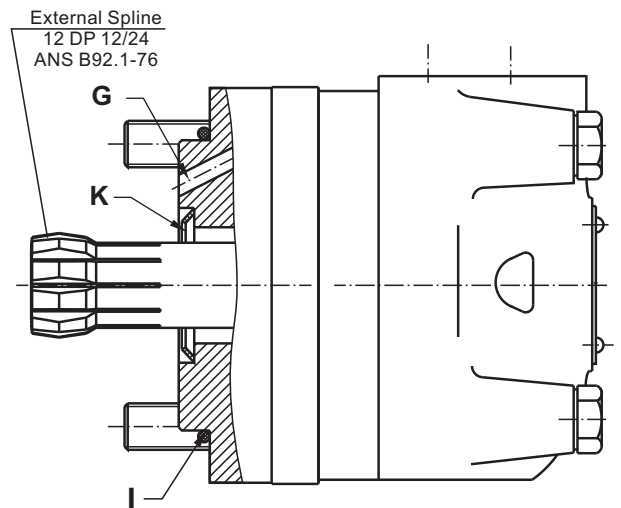
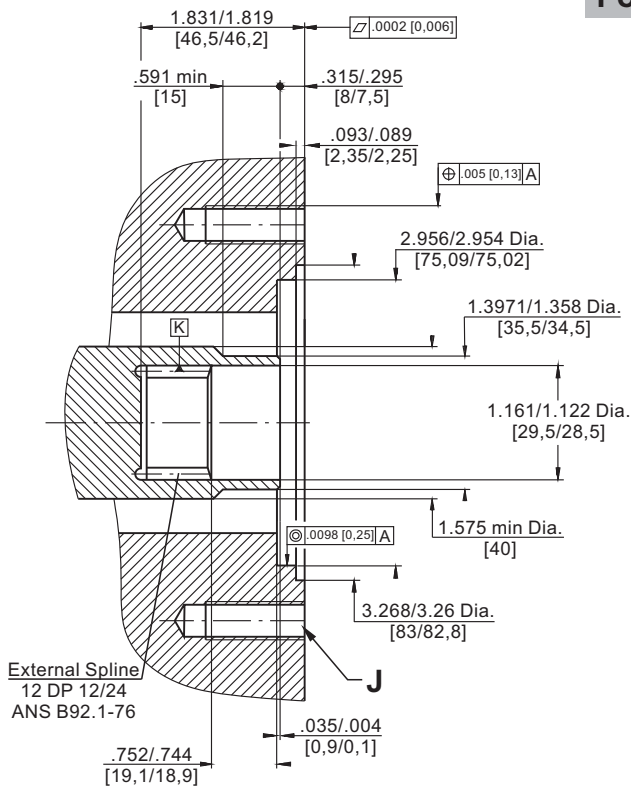

- I: "O"- Ring 2.95x .118 [75x3]
- J: 4xM10- min 1.024 [26] Deep, 90°, 4.095[104] Dia. B.C.
- G: Internal drain channel
- K: Conical seal ring

DRAIN CONNECTION

A drain line has to be used when pressure in the return line can exceed the permissible pressure. It can be connected:

- For MLHSS, MLHSZ at the drain port of the motor;
- For MLHSV, MLHSU at the drain connection of the attached component. The maximum pressure in the drain line is limited by the attached component and its shaft seal.

The drain line must be possible for oil to flow freely between motor and attached component and must be led to the tank. The maximum pressure in the drain line is limited by the attached component and its seal.

INTERNAL SPLINE DATA FOR THE ATTACHED COMPONENT

Standard ANS B92.1-1976, class 5
[$m=2.1166$; corrected $x.m=0.8$]

Fillet Root Side Fit		inch	mm
Number of Teeth	z	12	12
Diametral Pitch	DP	12/24	12/24
Pressure Angle		30°	30°
Pitch Dia.	D	1	25,4
Major Dia.	D _{ri}	1.1 ÷ 1.098	28,0 _{-0,1}
Minor Dia.	D _i	.907 ÷ .905	23,0 ^{+0,033}
Space Width [Circular]	L _o	.1704 ÷ .1688	4,308±0,020
Fillet Radius	R	.008	0,2
Max. Measurement between Pins	L	.699 ÷ .694	17,62 ^{+0,15}
Pin Dia.	d	.19039 ÷ .19031	4,835±0,001

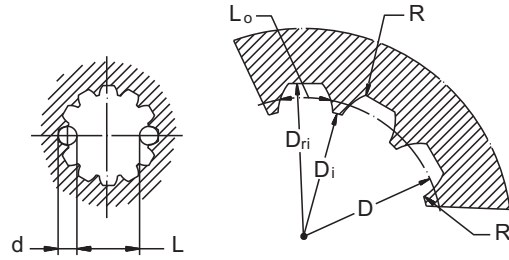

Hardening Specification:
 HV=750±50 on the surface.
 HV=560 at .035±.019 [0,7±0,2] case depth.
 Material: 20 MoCr4 DIN 17210 or SAE8620.

ORDER CODE

1	2	3	4	5	6	7	8
MLHS							

Pos.1 - Mounting Flange

- omit - SAE A-4, four holes
- A** - SAE A-2, two holes
- B** - SAE B, two holes
- E** - Wheel mount, 4.25 Pilot Dia.**
- F** - Magneto, four holes (six holes at customer's request)
- S** - Short
- V** - Very short
- U** - Ultra short
- W** - Wheel mount, 5.00 Pilot Dia.
- Z***** - Short, with place for needle bearing
- BD** - With drum brake

Pos.2 - Displacement code

- 80** - 4.91 in³/rev [80,5 cm³/rev]
- 100** - 6.10 in³/rev [100,0 cm³/rev]
- 125** - 7.67 in³/rev [125,7 cm³/rev]
- 160** - 9.74 in³/rev [159,7 cm³/rev]
- 200** - 12.20 in³/rev [200,0 cm³/rev]
- 250** - 15.30 in³/rev [250,0 cm³/rev]
- 315** - 19.20 in³/rev [314,9 cm³/rev]
- 400** - 24.20 in³/rev [397,0 cm³/rev]
- 475** - 28.96 in³/rev [474,6 cm³/rev]
- 525** - 31.88 in³/rev [522,7 cm³/rev]
- 565** - 34.47 in³/rev [564,9 cm³/rev]

Notes:

- * The permissible output torque for shafts must not be exceeded!
- ** The motor MLHSE is not available with shafts D, P, SW, SA.
- *** MLHSZ is available to max 400 displacement.

The hydraulic motors are mangano-phosphatized as standard.

Pos. 3 - Shaft Extensions*

- omit - for **BD, S, Z, V** and **U** mounting flange
- C** - 1¼" [31,75] straight, Parallel key
- D** - 1" [25,4] straight, Parallel key
- G** - 1¼" [31,75] 14T Splined
- M** - 32 mm straight, Parallel key
- P** - 34,85 mm Splined, p.t.o. DIN 9611 Form 1
- S** - 1" [25,4] SAE 6B Splined
[Max. Torque 3900 in-lb [44 daNm]
- SW** - 1" [25,4] SAE 6B Splined
[Max. Torque 3400 in-lb [38 daNm]
- SA** - 7/8"-13T splined ANS B92.1-1970
- T** - 1¼" [31,75] J501 Tapered

Pos. 4 - Actuating Direction [for MLHSBD only]

- /R** - right
- /L** - left

Pos. 5 - Port Size/Type [standard manifold to each]

- 2** - side ports, 2xG1/2, G1/4, BSP thread, ISO 228
- 3** - side ports, 2xM22x1,5; M14x1,5; metric thread, ISO 262
- 4** - side ports, 2x7/8-14 UNF, O-ring, 7/16-20 UNF
- 5** - side ports, 2x1/2-14 NPTF, 7/16-20 UNF
- 6** - rear ports, 2xG1/2; G1/4; BSP thread, ISO 228
- 7** - rear ports, 2x7/8-14 UNF, O-ring, 7/16-20 UNF
- 8** - rear ports, 2x1/2-14 NPTF, 7/16-20 UNF
- 9** - rear ports, 2xM22x1,5, M14x1,5; metric thread, ISO 262

Pos. 6 - Shaft Seal Version (see page 12)

- omit - Low pressure seal
- U** - High pressure seal

Pos. 7 - Special Features [see page 57]

Pos. 8 - Design Series

- omit - Factory specified