

HYDRAULIC MOTORS MVM

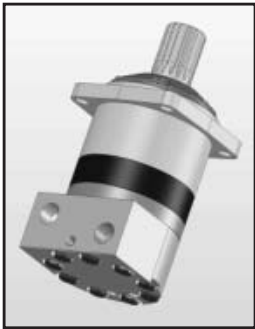

APPLICATION

- » Conveyors
- » Metal working machines
- » Agricultural machines
- » Road building machines
- » Mining machinery
- » Food industries
- » Special vehicles
- » Plastic and rubber machinery etc.

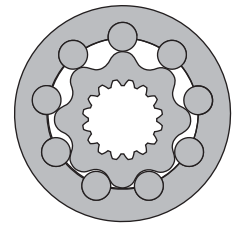
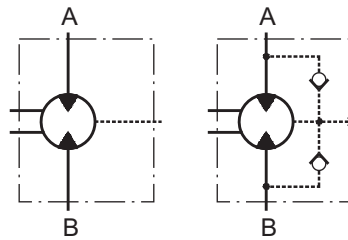

CONTENTS

Specification data	39
Dimensions and mounting	40
Shaft extensions	41
Permissible shaft Seal Pressure	41
Permissible shaft loads	42
Order code	42

OPTIONS

- » Model - Disc valve, roll-gerotor
- » Flange with wheel mount
- » Short motor
- » Side ports
- » Shafts - straight, splined and tapered
- » BSPP ports;
- » Other special features.

EXCELLENCE

- » High torque and pressure drop
- » High inlet pressure
- » High starting torque
- » Improved efficiency at high pressure drop
- » Smooth operation at low speed
- » High radial and axial bearing capacity

GENERAL

Max. Displacement, cm ³ /rev [in ³ /rev]	801,8 [48.91]
Max. Speed, [RPM]	763
Max. Torque, daNm [lb-in]	cont.: 259 [22920] int.: 340 [30090]
Max. Output, kW [HP]	112 [150]
Max. Pressure Drop, bar [PSI]	cont.: 250 [3630] int.: 350 [5080]
Max. Oil Flow, lpm [GPM]	240 [63.4]
Min. Speed, [RPM]	5
Permissible Shaft Loads, daN [lbs]	Pa=1500 [3370]
Pressure fluid	Mineral based- HLP(DIN 51524) or HM(ISO 6743/4)
Temperature range, °C [°F]	-40÷140 [-40÷284]
Optimal Viscosity range, mm ² /s [SUS]	20÷75 [98÷347]
Filtration	ISO code 20/16 (Min. recommended fluid filtration of 25 microns)

Oil flow in drain line

Pressure drop bar [PSI]	Viscosity mm ² /s [SUS]	Oil flow in drain line lpm [GPM]
140 [2030]	20 [98]	3 [.793]
	35 [164]	2 [.528]
210 [3045]	20 [98]	6 [1.585]
	35 [164]	4 [1.057]

Pressure Losses

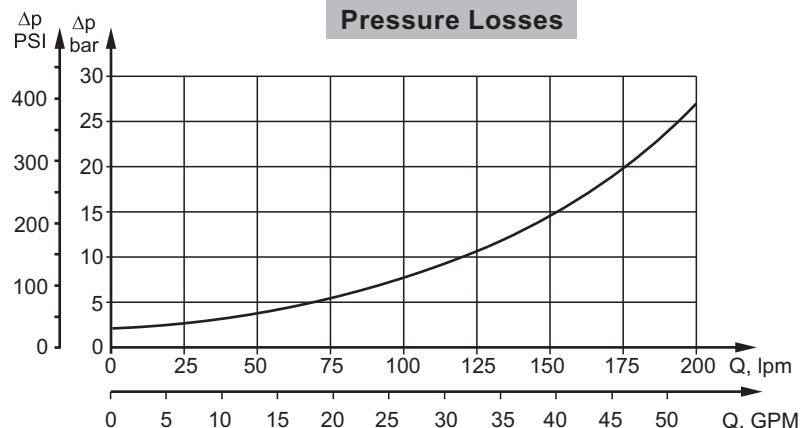

SPECIFICATION DATA

Type	MVM 315	MVM 400	MVM 500	MVM 630	MVM 800	
Displacement, cm³/rev [in³/rev]	314,5 [19.19]	400,9 [24.5]	499,6 [30.5]	629,1 [38.38]	801,8 [48.91]	
Max. Speed, [RPM]	cont.	636	500	400	315	250
	Int.*	763	600	480	380	300
Max. Torque daNm [lb-in]	cont.	115 [10180]	144 [12745]	180 [15930]	227 [20090]	259 [22920]
	Int.*	160 [14160]	200 [17700]	260 [23010]	310 [27440]	340 [30090]
	peak**	180 [15930]	230 [20355]	286 [25315]	360 [31860]	402 [35580]
Max. Output kW [HP]	cont.	67 [90]	67 [90]	67 [90]	67 [90]	67 [90]
	int.*	112 [150]	112 [150]	112 [150]	112 [150]	112 [150]
Max. Pressure Drop bar [PSI]	cont.	250 [3630]	250 [3630]	250 [3630]	250 [3630]	225 [3263]
	Int.*	350 [5080]	350 [5080]	350 [5080]	350 [5080]	300 [4350]
	peak**	400 [5800]	400 [5800]	400 [5800]	400 [5800]	350 [5080]
Max. Oil Flow lpm [GPM]	cont.	200 [52.8]	200 [52.8]	200 [52.8]	200 [52.8]	200 [52.8]
	Int.*	240 [63.4]	240 [63.4]	240 [63.4]	240 [63.4]	240 [63.4]
Max. Inlet Pressure bar [PSI]	cont.	270 [3915]	270 [3915]	270 [3915]	270 [3915]	270 [3915]
	Int.*	370 [5365]	370 [5365]	370 [5365]	370 [5365]	370 [5365]
	peak**	420 [6090]	420 [6090]	420 [6090]	420 [6090]	420 [6090]
Max. Return Pressure with Drain Line bar [PSI]	cont.	140 [2030]	140 [2030]	140 [2030]	140 [2030]	140 [2030]
	Int.*	175 [2540]	175 [2540]	175 [2540]	175 [2540]	175 [2540]
	peak**	210 [3045]	210 [3045]	210 [3045]	210 [3045]	210 [3045]
Max. Starting Pressure with Unloaded Shaft, bar [PSI]	5 [70]	5 [70]	5 [70]	5 [70]	5 [70]	
Min. Starting Torque daNm [lb-in]	92 [8140]	115 [10180]	144 [12745]	180 [15930]	205 [18145]	
Min. Speed***, [RPM]	10	6	8	6	5	
Weight, kg [lb]	41,3 [91]	42,1 [93]	43 [95]	44,5 [98]	46 [101.4]	

* Intermittent operation: the permissible values may occur for max. 10% of every minute.

** Peak load: the permissible values may occur for max. 1% of every minute.

*** For speeds lower than given, consult factory or your regional manager.

1. Intermittent speed and intermittent pressure must not occur simultaneously.
2. Recommended filtration is per ISO cleanliness code 20/16. A nominal filtration of 25 micron or better.
3. Recommend using a premium quality, anti-wear type mineral based hydraulic oil HLP (DIN51524) or HM (ISO 6743/4).
If using synthetic fluids consult the factory for alternative seal materials.
4. Recommended minimum oil viscosity 13 mm²/s [70 SUS] at 50°C [122°F].
5. Recommended maximum system operating temperature is 82°C [180°F].
6. To assure optimum motor life fill with fluid prior to loading and run at moderate load and speed for 10-15 minutes.

DIMENSIONS AND MOUNTING DATA

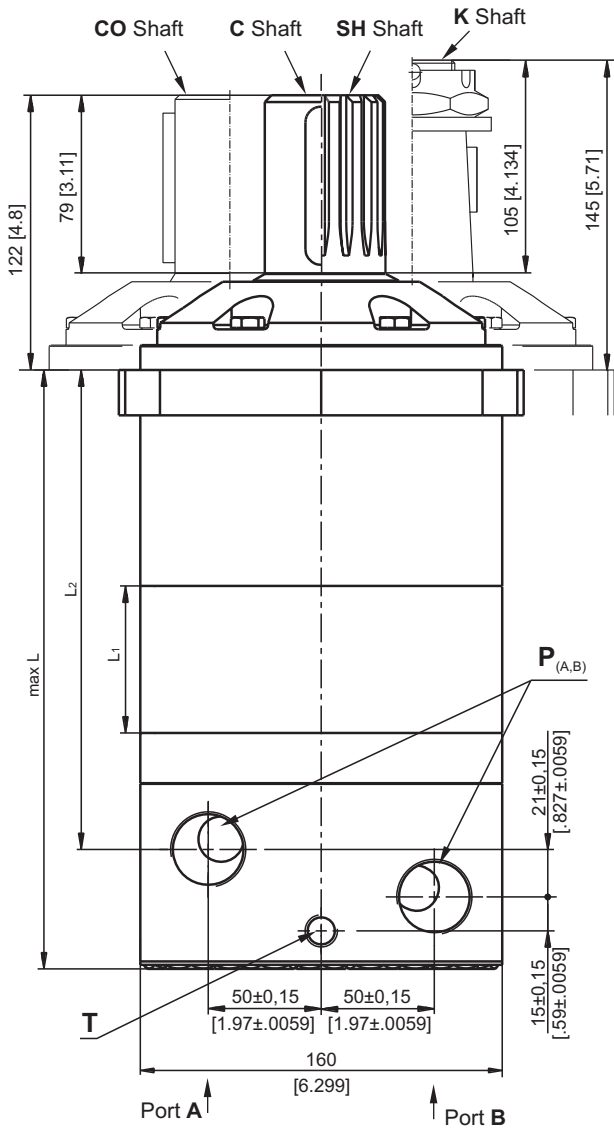

Shaft Dim.
See Page 41

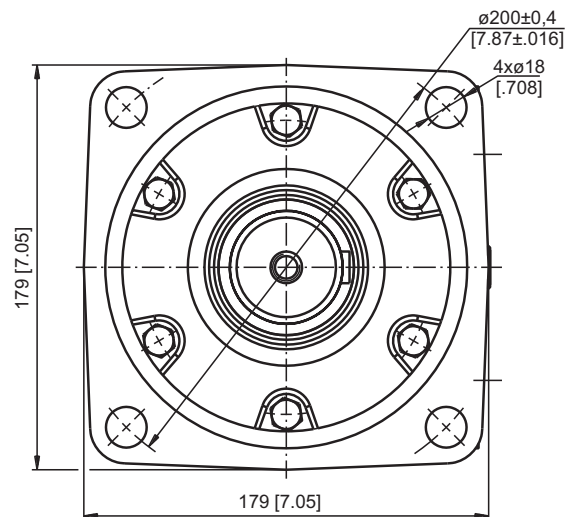
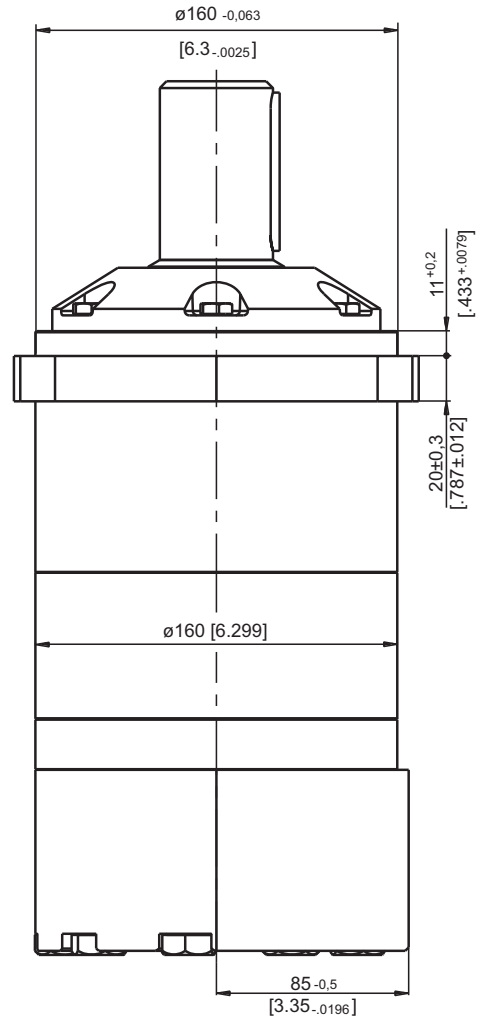

	Versions	
	2	4
P_(A,B)	2xG1	2x1 ⁵ / ₁₆ -12UN
T	G ¹ / ₄	9 ¹⁶ -18UNF

Warning: Drain line should always be used.

Type	L, mm [in]	L ₂ , mm [in]	L ₁ , mm [in]
MVM 315	226,5 [8.92]	172,5 [6.79]	25,5 [1.00]
MVM 400	233,5 [9.19]	179,5 [7.07]	32,5 [1.28]
MVM 500	241,5 [9.51]	187,5 [7.38]	40,5 [1.59]
MVM 630	252 [9.92]	198 [7.79]	51 [2.01]
MVM 800	266 [10.47]	212 [8.35]	65 [2.56]

Standard Rotation
Viewed from Shaft End
Port A Pressurized - CW
Port B Pressurized - CCW

Reverse Rotation
Viewed from Shaft End
Port A Pressurized - CCW
Port B Pressurized - CW



SHAFT EXTENSIONS

C - $\varnothing 50$ straight, Parallel key A14x9x70 DIN 6885

CO - $\varnothing 2\frac{1}{4}$ " [57,15] straight, Parallel key $\frac{1}{2}$ " x $\frac{1}{2}$ " x $2\frac{1}{4}$ " BS46

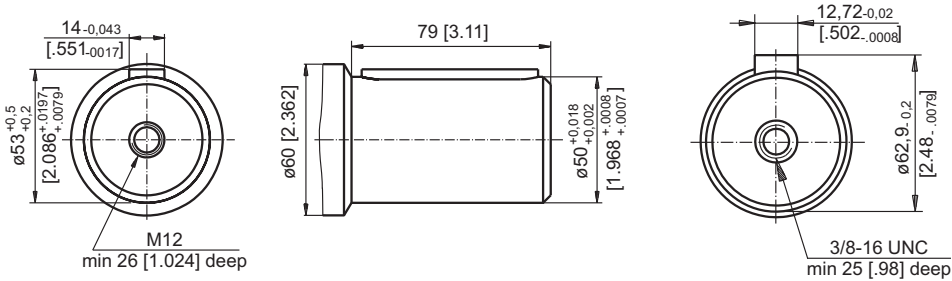

SH - $\varnothing 2\frac{1}{8}$ " splined, 16 DP 8/16 ANS B92.1-1976

K - tapered 1:10, Parallel key B16x10x32 DIN 6885

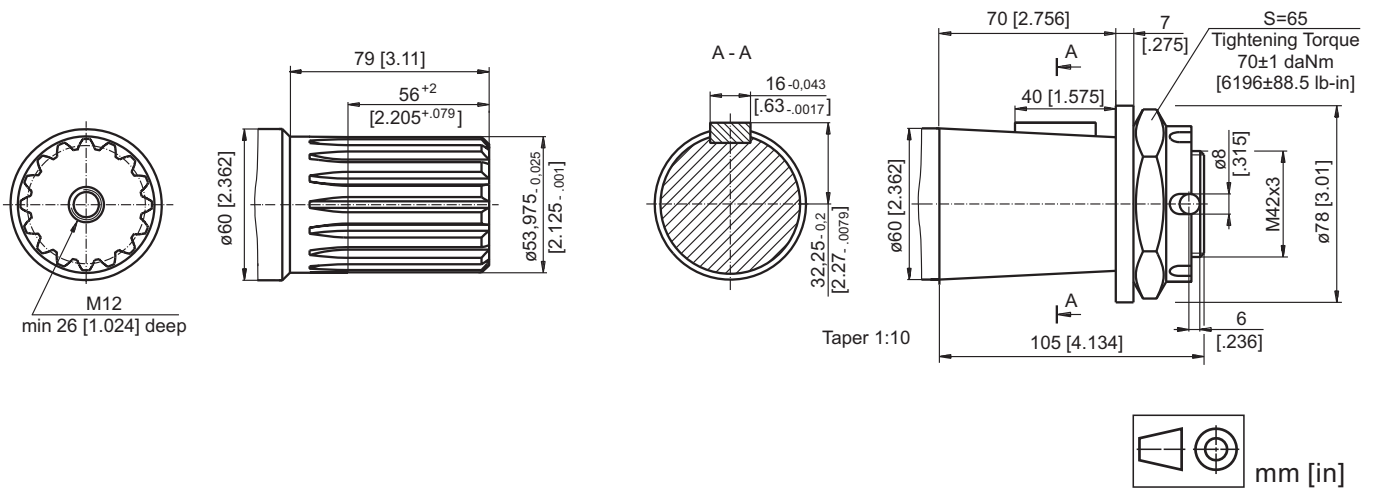

MAX. PERMISSIBLE SHAFT SEAL PRESSURE

**Max. return pressure without drain line or
max. pressure in the drain line**

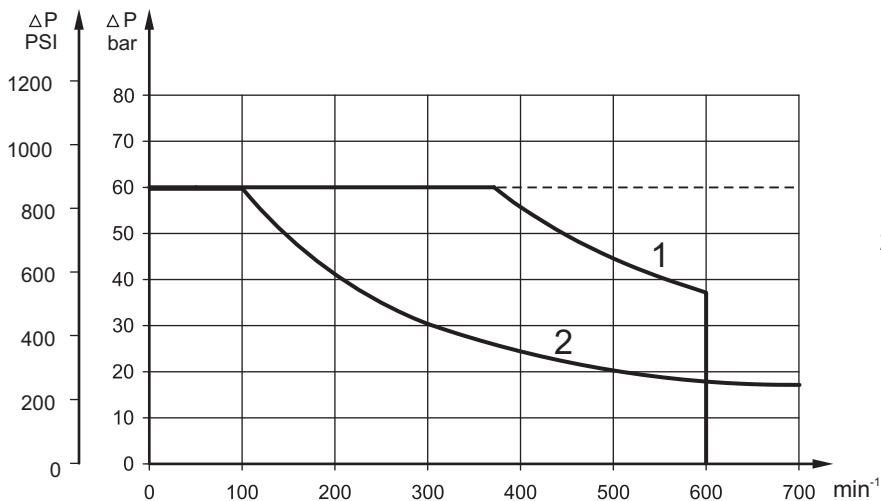

1: Drawing for High Pressure Seal ("U" Seal)
2: Drawing for Standard Shaft Seal

— - continuous operations
- - - - intermittent operations

PERMISSIBLE SHAFT LOADS

The output shaft runs in tapered bearings that permit high axial and radial forces. Curve "1" shows max. radial shaft load. Any shaft load exceeding the values shown by the curve will seriously reduce motor life. The two other curves apply to a B10 bearing life of 3000 hours at 200 RPM.

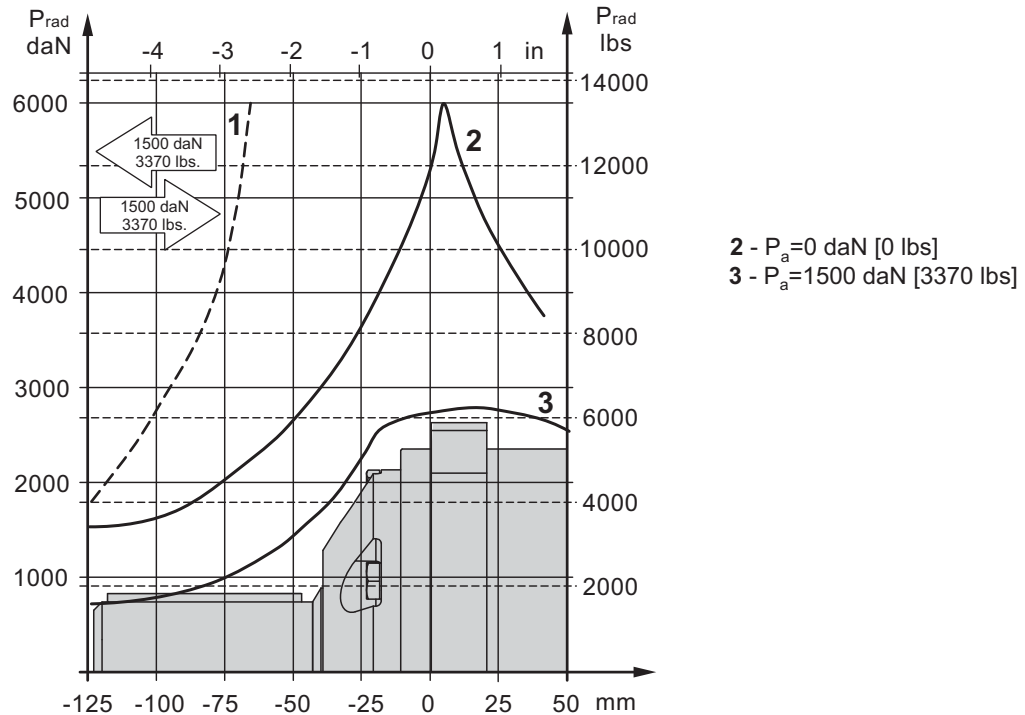

ORDER CODE

	1	2	3	4	5	6	7
M V M						HD	

- Pos.1 - Displacement code**
- 315** - 314,5 cm³/rev [19.8 in³/rev]
 - 400** - 400,9 cm³/rev [24.45 in³/rev]
 - 500** - 499,6 cm³/rev [30.48 in³/rev]
 - 630** - 629,1 cm³/rev [38.38 in³/rev]
 - 800** - 801,8 cm³/rev [48.91 in³/rev]
- Pos.2 - Shaft Extensions***
- C** - $\varnothing 50$ straight, Parallel key A14x9x70 DIN6885
 - CO** - $\varnothing 2\frac{1}{4}$ " straight, Parallel key $\frac{1}{2}$ "x $\frac{1}{2}$ "x $2\frac{1}{4}$ " BS 46
 - SH** - $\varnothing 2\frac{1}{8}$ " splined, ANSI B92.1-1976
 - K** - $\varnothing 60$ tapered 1:10, Parallel key B16x10x32 DIN6885

- Pos.3 - Ports**
- 2** - side ports, 2xG1, G1/4, BSP thread, ISO 228
 - 4** - side ports, 2x1 5/16-12 UN, O-ring, 9/16-18 UNF
- Pos.4 - Check Valves**
- omit - without check valves
 - 1** - with check valves
- Pos.5 - Shaft Seal Version (see page 41)**
- omit - Low pressure shaft seal
 - U** - High pressure shaft seal
- Pos.6 - Special Features (see page 52)**
- HD** - Reinforced motor HD**
For Other **Special Features** see page 52
- Pos.7 - Design Series**
- omit - Factory specified

NOTES:

- * The permissible output torque for shafts must not be exceeded!
- ** Drain line should always be used.

The hydraulic motors are mangano-phosphatized as standard.

MOTOR SPECIAL FEATURES

Special Feature Description	Order Code	Motor type						
		MSWM	MTK	MTM	TMF	MVM	MVMC	VMF
Speed Sensor*	RS	O	O	O	O	O	-	O
Reinforced motor	HD	-	S	S	S	S	S	S
Low Leakage	LL	O	O	O	O	O	O	O
Low Speed Valving	LSV	O	O	O	O	O	O	O
Free Running	FR	-	O	-	-	-	O	-
Reverse Rotation	R	O	O	O	O	O	O	O
Paint**	P	O	O	O	O	O	O	O
Corrosion Protected Paint**	PC	O	O	O	O	O	O	O
Special Paint***	PS	O	O	O	O	O	O	O
	PCS	O	O	O	O	O	O	O
Check Valves		S	O	O	-	O	O	-

O	Optional
-	Not applicable
S	Standard

* For sensor ordering see pages 53÷54.

** Colour at customer's request.

*** Non painted feeding surfaces, colour at customer's request.

 For more information about **HD** option please contact with "M+S Hydraulic".

MOTORS WITH SPEED SENSOR

MSWM...RS

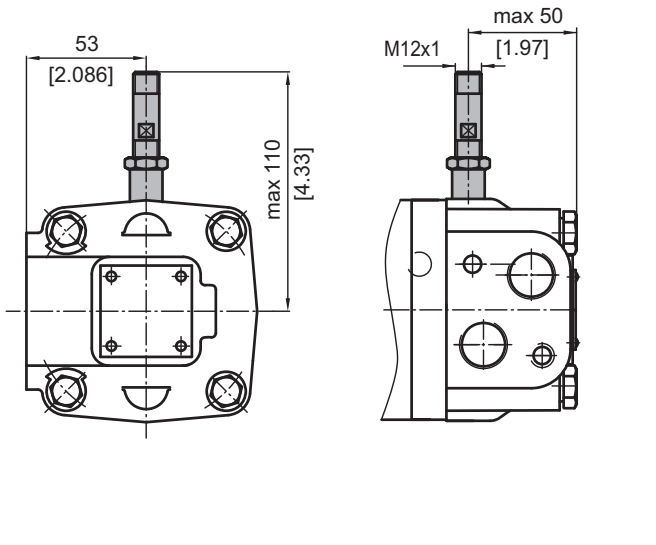

MTK...RS

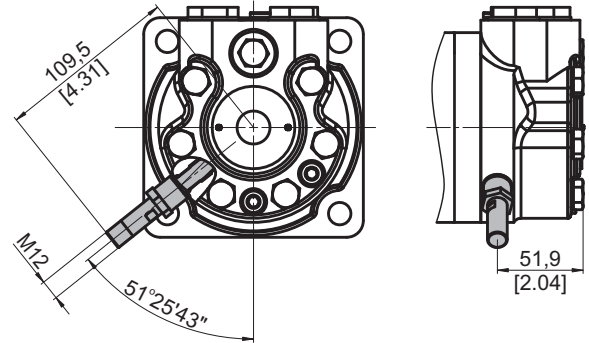

MTM...RS TMF...RS

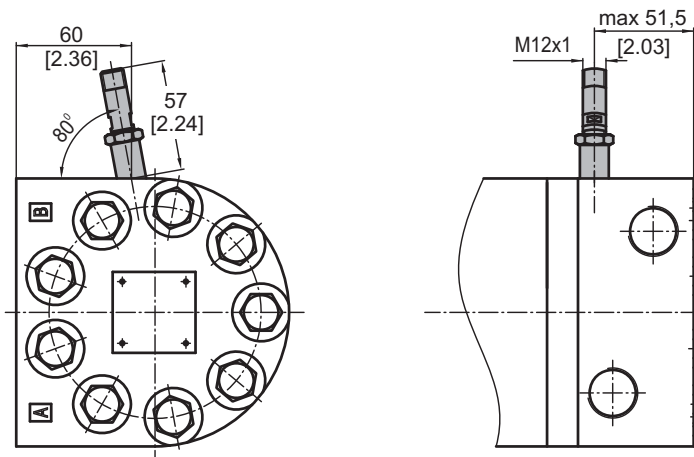

MVM...RS VMF...RS

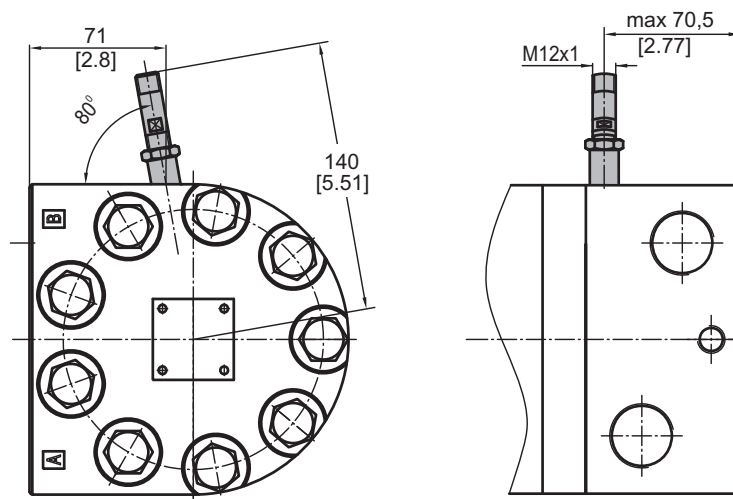

TECHNICAL DATA OF THE SPEED SENSOR

Technical data

Frequency range	0...15 000 Hz
Output	PNP, NPN
Power supply	10...36 VDC
Current input	20 mA (@24 VDC)
Ambient Temperature	-40...+125°C [-40...+257°F]
Protection	IP 67
Plug connector	M12-Series
Mounting principle	ISO 6149

Output signal

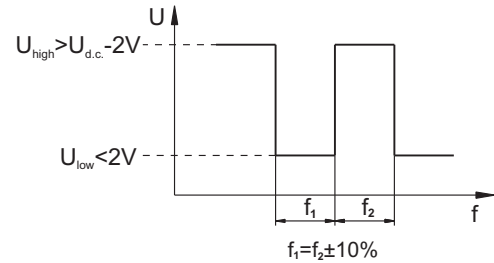

Load max.: $I_{high} = I_{low} < 50\text{mA}$

Motor type	MSWM MTK	MTM TMF	MVM VMF
Pulses per revolution	54	84	102

Wiring diagrams

PNP

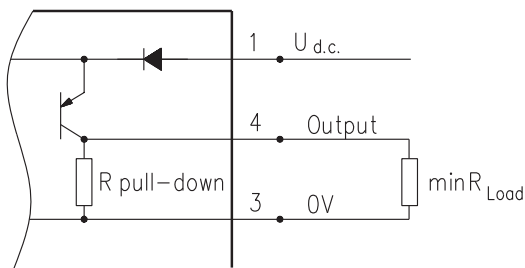

NPN

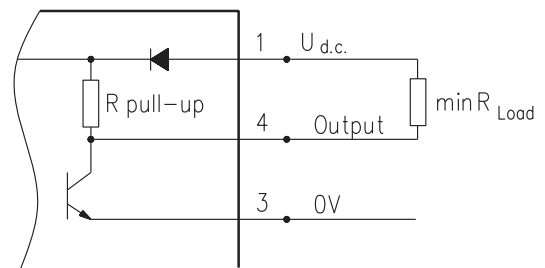

$$R_{Load} [\text{k}\Omega] = U_{d.c.} [\text{V}] / I_{max} [\text{mA}]$$

Stick type

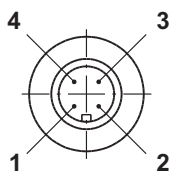

Terminal No.	Connection	Cable Output
1	$U_{d.c.}$	Brown
2	No connection	White
3	0V	Blue
4	Output signal	Black

Order Code for Speed Sensor

Sensor Code	Output type	Electric connection
RSN	NPN	Connector BINDER 713 series
RSP	PNP	Connector BINDER 713 series
RSNL5	NPN	Cable output 3x0,25; 5 m [196 in] long
RSPL5	PNP	Cable output 3x0,25; 5 m [196 in] long

NOTE: *- The speed sensor is not fitted at the factory, but is supplied in a plastic bag with the motor. For installation see enclosed instructions.

APPLICATION CALCULATION

VEHICLE DRIVE CALCULATIONS

1. Motor speed: n, RPM

$$n = \frac{2,65 \times v_{km} \times i}{R_m} \quad n = \frac{168 \times v_{mi} \times i}{R_{in}}$$

v_{km} - vehicle speed, km/h;

v_{mi} - vehicle speed, mil/h;

R_m - wheel rolling radius, m;

R_{in} - wheel rolling radius, in;

i - gear ratio between motor and wheels.

If no gearbox, use $i=1$.

2. Rolling resistance: RR, daN [lbs]

The resistance force resulted in wheels contact with different surfaces:

$$RR = G \times \rho$$

G - total weight loaded on vehicle, daN [lbs];

ρ - rolling resistance coefficient (Table 1).

Table 1

Rolling resistance coefficient In case of rubber tire rolling on different surfaces	
Surface	ρ
Concrete- faultless	0.010
Concrete- good	0.015
Concrete- bad	0.020
Asphalt- faultless	0.012
Asphalt- good	0.017
Asphalt- bad	0.022
Macadam- faultless	0.015
Macadam- good	0.022
Macadam- bad	0.037
Snow- 5 cm	0.025
Snow- 10 cm	0.037
Polluted covering- smooth	0.025
Polluted covering- sandy	0.040
Mud	0.037÷0.150
Sand- Gravel	0.060÷0.150
Sand- loose	0.160÷0.300

3. Grade resistance: GR, daN [lbs]

$$GR = G \times (\sin \alpha + \rho \times \cos \alpha)$$

α - gradient negotiation angle (Table 2)

Table 2

Grade %	α Degrees	Grade %	α Degrees
1%	0° 35'	12%	6° 5'
2%	1° 9'	15%	8° 31'
5%	2° 51'	20%	11° 19'
6%	3° 26'	25%	14° 3'
8%	4° 35'	32%	18°
10%	5° 43'	60%	31°

4. Acceleration force: FA, daN [lbs]

Force FA necessary for acceleration from 0 to maximum speed v and time t can be calculated with a formula:

$$FA = \frac{v_{km} \times G}{3,6 \times t}, [\text{daN}] \quad FA = \frac{v_{mi} \times G}{22 \times t}, [\text{lbs}];$$

FA - acceleration force, daN [lbs];

t - time, [s].

5. Tractive effort: DP, daN [lbs]

Tractive effort DP is the additional force of trailer. This value will be established as follows:

-acc.to constructor's assessment;

-as calculating forces in items 2, 3 and 4 of trailer; the calculated sum corresponds to the tractive effort requested.

6. Total tractive effort: TE, daN [lbs]

Total tractive effort TE is total effort necessary for vehicle motion; that the sum of forces calculated in items from 2 to 5 and increased with 10 % because of air resistance.

$$TE = 1,1 \times (RR + GR + FA + DP)$$

RR - force acquired to overcome the rolling resistance;

GR - force acquired to slope upwards;

FA - force acquired to accelerate (acceleration force);

DP - additional tractive effort (trailer).

7. Motor Torque moment: M, daNm [lb-in]

Necessary torque moment for every hydraulic motor:

$$M = \frac{TE \times R_m [R_{in}]}{N \times i \times \eta_m}$$

N - motor numbers;

η_m - mechanical gear efficiency (if it is available).

8. Cohesion between tire and road covering: M_w, daNm [lb-in]

$$M_w = \frac{G_w \times f \times R_m [R_{in}]}{i \times \eta_m}$$

To avoid wheel slipping, the following condition should be observed $M_w > M$

f - frictional factor;

G_w - total weight over the wheels, daN [lbs].

Table 3

Surface	Frictional factor f
Steel on steel	0.15 ÷ 0.20
Rubber tire on polluted surface	0.5 ÷ 0.7
Rubber tire on asphalt	0.8 ÷ 1.0
Rubber tire on concrete	0.8 ÷ 1.0
Rubber tire on grass	0.4

9.Radial motor loading: P_{rad} , daN [lbs]

When motor is used for vehicle motion with wheels mounted directly on motor shaft, the total radial loading of motor shaft P_{rad} is a sum of motion force and weight force acting on one wheel.

- G_w - Weight held by wheel;
- P_{rad} - Total radial loading of motor shaft;
- M/R - Motion force.

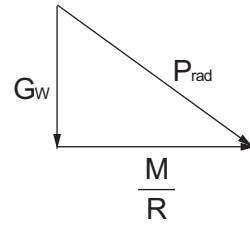

$$P_{rad} = \sqrt{G_w^2 + \left(\frac{M}{R}\right)^2}$$

In accordance with calculated loadings the suitable motor from the catalogue is selected.

DRAINAGE SPACE AND DRAINAGE PRESSURE

Advantages in oil drainage from drain space: Cleaning; Cooling and Seal lifetime prolonging.

