

Series NF 250

232 PSI

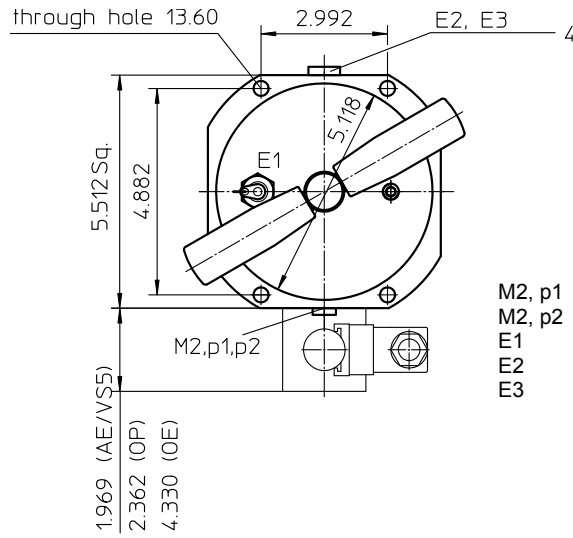

- M2, p1 = measure connection dirt side
- M2, p2 = measure connection clean side
- E1 = air bleeding dirt side
- E2 = drain dirt side
- E3 = drain clean side

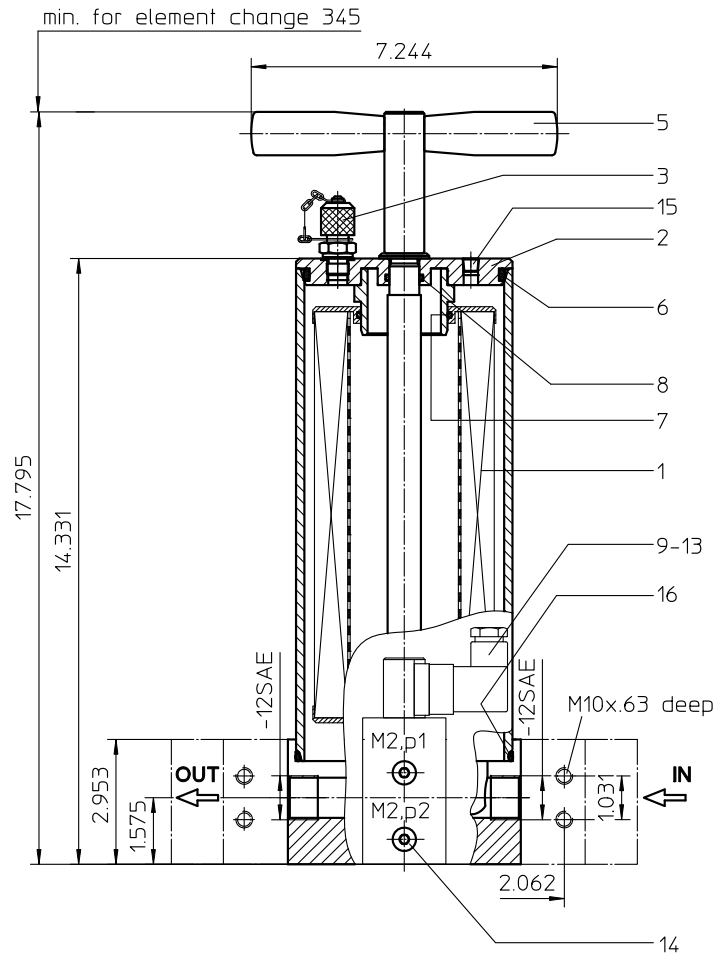

Weight: approx. 16 lbs.

Dimensions: inches

Designs and performance values are subject to change.



Powering Business Worldwide

Offline Filter

Series NF 250

232 PSI

Description:

The offline filter series NF is used for fine filtration of hydraulic or lubrication circuits. This filter is designed to be installed in an offline filtration circuit, independent of the main circuit. This filter is designed to have a high dirt holding capacity which will provide a long service life.

The filter is flanged mounted to the line.

The filter element consists of star-shaped, pleated filter material, which is supported on the inside by a perforated core tube and is bonded to the end caps with a high-quality adhesive. The flow direction is from outside to inside. Filter elements are available down to 5 $\mu\text{m}_{(c)}$. Finer filtration is available upon request.

Changing the elements is possible without tools. Release the key handle and remove the cover to access the elements.

Eaton filter elements are known for high intrinsic stability and an excellent filtration capability, a high dirt-retaining capacity and a long service life.

1. Type index:

1.1. Complete filter: (ordering example)

NF.	250.	10VG.	10.	B.	P.	-.	FS.	5.	-.	AE
1	2	3	4	5	6	7	8	9	10	11

- 1 | **series:**
NF = offline filter
- 2 | **nominal size:** 250
- 3 | **filter-material and filter-fineness:**
80G, 40G, 25G, 10G stainless steel wire mesh
25VG, 16VG, 10VG, 6VG, 3VG microglass
10WVG, 3WVG watersorp-filter element
- 4 | **resistance of pressure difference for filter element:**
10 = Δp 145 PSI
- 5 | **filter element design:**
B = both sides open
- 6 | **sealing material:**
P = Nitrile (NBR)
V = Viton (FPM)
- 7 | **filter element specification:** (see catalog)
- = standard
VA = stainless steel
IS06 = for HFC applications, see sheet-no. 31601
- 8 | **process connection:**
FS = SAE-flange 3000 PSI ¹⁾
- 9 | **process connection size:**
5 = 1" ¹⁾
- 10 | **filter housing specification:** (see catalog)
- = standard
IS06 = for HFC applications, see sheet-no. 31605
- 11 | **clogging indicator or clogging sensor:**
- = without
AE = visual-electric, see sheet-no. 1609
OP = visual, see sheet-no. 1628
OE = visual-electric, see sheet-no. 1628
VS5 = electronic, see sheet-no. 1641

¹⁾ in addition available
thread -12 SAE according to DIN 3852 T2, design Z

To add an indicator to your filter, use the corresponding indicator data sheet to find the indicator details and add them to the filter assembly model code.

1.2. Filter element: (ordering example)

01NR.	250.	10VG.	10.	B.	P.	-
1	2	3	4	5	6	7

- 1 | **series:**
01NR. = standard return line filter element according to DIN 24550, part 4
- 2 | **nominal size:** 250
- 3 | - 7 | see type index-complete filter

Accessories:

- gauge port- and bleeder connection, see sheet-no. 1650
- drain- and bleeder connection, see sheet-no. 1651

Technical data:

design temperature:	14 °F to +212 °F
operating temperature:	14 °F to +176 °F
operating medium	mineral oil, other media on request
max. operating pressure:	232 PSI
test pressure:	333 PSI
process connection:	SAE-flange 3000 PSI
housing material:	aluminium forging alloy
sealing material:	Nitrile (NBR) or Viton (FPM), other materials on request
installation position:	vertical
measure connections:	BSPP 1/8
drain- and bleeder connections:	BSPP 1/4
volume tank:	.87 Gal.

Classified under the Pressure Equipment Directive 2014/68/EC for mineral oil (fluid group 2), Article 4, Para. 3.
 Classified under ATEX Directive 2014/34/EC according to specific application (see questionnaire sheet-no. 34279-4).

Pressure drop flow curves:

Filter calculation/sizing

The pressure drop of the assembly at a given flow rate Q is the sum of the housing Δp and the element Δp and is calculated as follows:

$$\Delta p_{assembly} = \Delta p_{housing} + \Delta p_{element}$$

$$\Delta p_{housing} = (\text{see } \Delta p = f(Q) \text{ - characteristics})$$

$$\Delta p_{element} (PSI) = Q (GPM) \times \frac{MSK}{1000} \left(\frac{PSI}{GPM} \right) \times \nu (SUS) \times \frac{\rho}{0.876} \left(\frac{kg}{dm^3} \right)$$

For ease of calculation our Filter Selection tool is available online at www.eatonpowersource.com/calculators/filtration/

Material gradient coefficients (MSK) for filter elements

The material gradient coefficients in psi/gpm apply to mineral oil (HLP) with a density of 0.876 kg/dm³ and a kinematic viscosity of 139 SUS (30 mm²/s). The pressure drop changes proportionally to the change in kinematic viscosity and density.

NF	VG				
	3VG	6VG	10VG	16VG	25VG
250	0.669	0.464	0.297	0.259	0.177

$\Delta p = f(Q)$ – characteristics according to ISO 3968

The pressure drop characteristics apply to mineral oil (HLP) with a density of 0.876 kg/dm³. The pressure drop changes proportionally to the density.

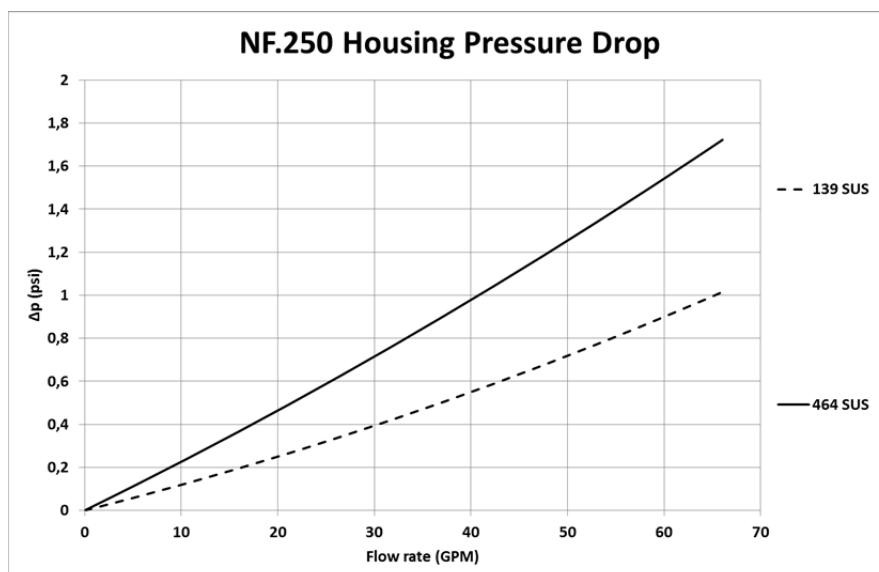

Symbols:

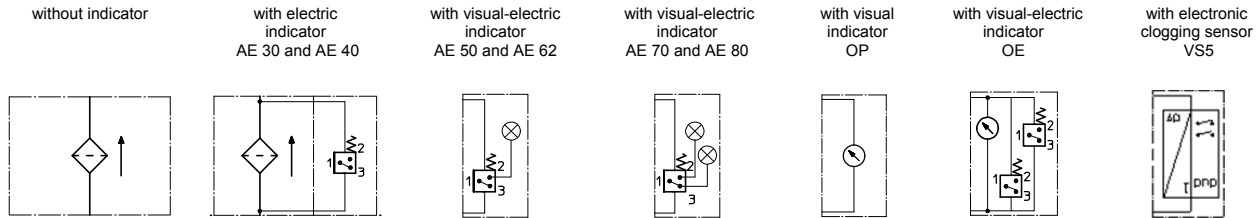

Spare parts:

item	qty.	designation	dimension	article-no.
1	1	filter element	01NR.250...	
2	1	filter cover	30615-3	315437
3	1	mini-measuring connection	MA.1.ST	305453
4	2	screw plug	1/4 BSPP	305003
5	1	straining screw	30631-3	316404
6	1	O-ring	110 x 6	337001 (NBR) 337002 (FPM)
7	2	O-ring	52 x 3	314206 (NBR) 316698 (FPM)
8	1	O-ring	18 x 3	304359 (NBR) 304399 (FPM)
9	1	clogging indicator, visual	OP	see sheet-no. 1628
10	1	clogging indicator, visual-electric	OE	see sheet-no. 1628
11	1	clogging indicator, visual-electric	AE	see sheet-no. 1609
12	1	clogging sensor, electronic	VS5	see sheet-no. 1641
13	2	O-ring	14 x 2	304342 (NBR) 304722 (FPM)
14	2	screw plug	1/8 BSPP	304791
15	1	screw plug	1/8 BSPP	305496
16	1	O-ring	123 x 4	337003 (NBR) 337004 (FPM)

item 14 execution only without clogging indicator or clogging sensor

Test methods:

Filter elements are tested according to the following ISO standards:

ISO 2941	Verification of collapse/burst resistance
ISO 2942	Verification of fabrication integrity
ISO 2943	Verification of material compatibility with fluids
ISO 3723	Method for end load test
ISO 3724	Verification of flow fatigue characteristics
ISO 3968	Evaluation of pressure drop versus flow characteristics
ISO 16889	Multi-pass method for evaluating filtration performance

North America

44 Apple Street
Tinton Falls, NJ 07724
Toll Free: 800 656-3344
(North America only)
Tel: +1 732 212-4700

Europe/Africa/Middle East

Auf der Heide 2
53947 Nettersheim, Germany
Tel: +49 2486 809-0

Friedensstraße 41
68804 Altlußheim, Germany
Tel: +49 6205 2094-0

An den Nahewiesen 24
55450 Langerlonsheim, Germany
Tel: +49 6704 204-0

China

No. 3, Lane 280,
Linhong Road
Changning District, 200335
Shanghai, P.R. China
Tel: +86 21 5200-0099

Singapore

4 Loyang Lane #04-01/02
Singapore 508914
Tel: +65 6825-1668

Brazil

Av. Julia Gaioli, 474 – Bonsucesso
07251-500 – Guarulhos, Brazil
Tel: +55 11 2465-8822

**For more information, please
email us at filtration@eaton.com
or visit www.eaton.com/filtration**

© 2015 Eaton. All rights reserved. All trademarks and registered trademarks are the property of their respective owners. All information and recommendations appearing in this brochure concerning the use of products described herein are based on tests believed to be reliable. However, it is the user's responsibility to determine the suitability for his own use of such products. Since the actual use by others is beyond our control, no guarantee, expressed or implied, is made by Eaton as to the effects of such use or the results to be obtained. Eaton assumes no liability arising out of the use by others of such products. Nor is the information herein to be construed as absolutely complete, since additional information may be necessary or desirable when particular or exceptional conditions or circumstances exist or because of applicable laws or government regulations.

Series NF 631

232 PSI

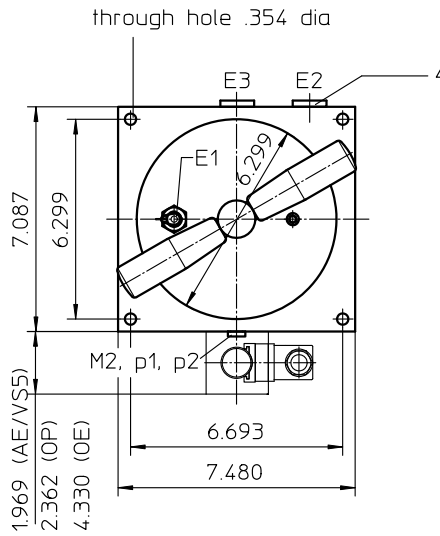

- M2, p1 = measure connection dirt side
- M2, p2 = measure connection clean side
- E1 = air bleeding dirt side
- E2 = drain dirt side
- E3 = drain clean side

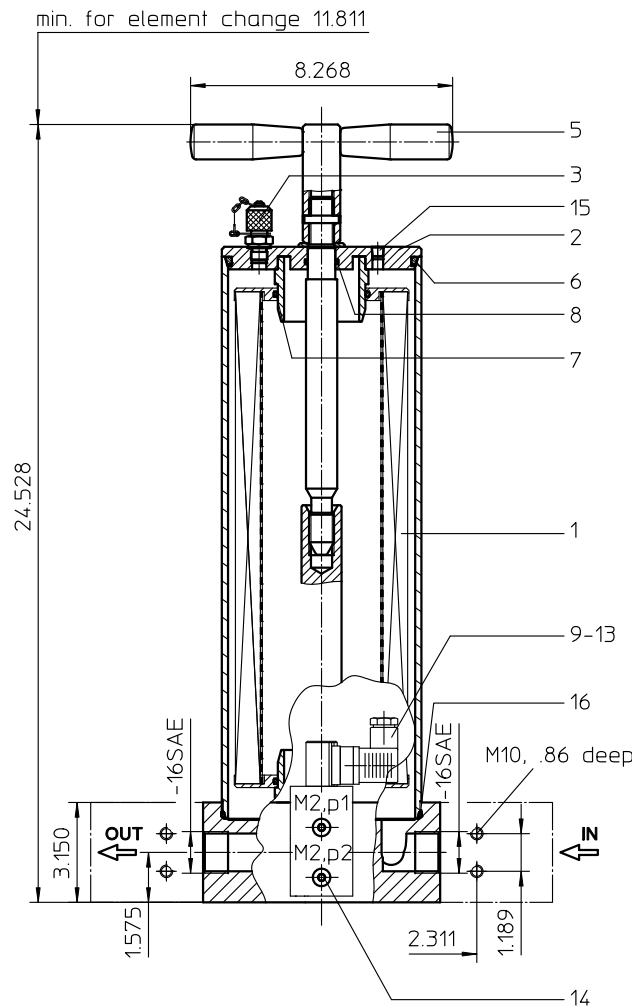

Weight: approx. 37 lbs.

Dimensions: inches

Designs and performance values are subject to change.

Offline Filter

Series NF 631

232 PSI

Description:

The offline filter series NF is used for fine filtration of hydraulic or lubrication circuits. This filter is designed to be installed in an offline filtration circuit, independent of the main circuit. This filter is designed to have a high dirt holding capacity which will provide a long service life.

The filter is flanged mounted to the line.

The filter element consists of star-shaped, pleated filter material, which is supported on the inside by a perforated core tube and is bonded to the end caps with a high-quality adhesive. The flow direction is from outside to inside. Filter elements are available down to 5 $\mu\text{m}_{(c)}$. Finer filtration is available upon request.

Changing the elements is possible without tools. Release the key handle and remove the cover to access the elements.

Eaton filter elements are known for high intrinsic stability and an excellent filtration capability, a high dirt-retaining capacity and a long service life.

1. Type index:

1.1. Complete filter: (ordering example)

NF. 631. 10VG. 10. B. P. -. FS. 6. -. AE

1	2	3	4	5	6	7	8	9	10	11
---	---	---	---	---	---	---	---	---	----	----

- 1 series:**
NF = offline filter
- 2 nominal size:** 631
- 3 filter-material and filter-fineness:**
80G, 40G, 25G, 10G stainless steel wire mesh
25VG, 16VG, 10VG, 6VG, 3VG microglass
10WVG, 3WVG watersorp-filter element
- 4 filter element collapse rating:**
10 = Δp 145 PSI
- 5 filter element design:**
B = both sides open
- 6 sealing material:**
P = Nitrile (NBR)
V = Viton (FPM)
- 7 filter element specification:** (see catalog)
- = standard
VA = stainless steel
IS06 = for HFC applications, see sheet-no. 31601
- 8 process connection:**
FS = SAE-flange 3000 PSI ¹⁾
- 9 process connection size:**
6 = 1 1/4" ¹⁾
- 10 filter housing specification:** (see catalog)
- = standard
IS06 = for HFC applications, see sheet-no. 31605
- 11 clogging indicator or clogging sensor:**
- = without
AE = visual-electric, see sheet-no. 1609
OP = visual, see sheet-no. 1628
OE = visual-electric, see sheet-no. 1628
VS5 = electronic, see sheet-no. 1641

¹⁾ in addition available
thread -16 SAE according to DIN 3852 T2, design Z

To add an indicator to your filter, use the corresponding indicator data sheet to find the indicator details and add them to the filter assembly model code.

1.2. Filter element: (ordering example)

01NR. 630. 10VG. 10. B. P. -

1	2	3	4	5	6	7
---	---	---	---	---	---	---

- 1 series:**
01NR. = standard return line filter element according to DIN 24550, part 4
- 2 nominal size:** 630
- 3 - 7** see type index-complete filter

Accessories:

- gauge port- and bleeder connection, see sheet-no. 1650
- drain- and bleeder connection, see sheet-no. 1651
- SAE-counter flange, see sheet no. 1652

Technical data:

design temperature:	14 °F to +212 °F
operating temperature:	14 °F to +176 °F
operating medium:	mineral oil, other media on request
max. operating pressure:	232 PSI
test pressure:	333 PSI
process connection:	SAE-flange 3000 PSI
housing material:	aluminum forging alloy
sealing material:	Nitrile (NBR) or Viton (FPM), other materials on request
installation position:	vertical
measure connections:	BSPP ¼
drain- and bleeder connections:	BSPP ½
volume tank:	1.90 Gal.

Classified under the Pressure Equipment Directive 2014/68/EC for mineral oil (fluid group 2), Article 4, Para. 3.
 Classified under ATEX Directive 2014/34/EC according to specific application (see questionnaire sheet-no. 34279-4).

Pressure drop flow curves:

Filter calculation/sizing

The pressure drop of the assembly at a given flow rate Q is the sum of the housing Δp and the element Δp and is calculated as follows:

$$\Delta p_{assembly} = \Delta p_{housing} + \Delta p_{element}$$

$$\Delta p_{housing} = (\text{see } \Delta p = f(Q) \text{ - characteristics})$$

$$\Delta p_{element} (PSI) = Q (GPM) \times \frac{MSK}{1000} \left(\frac{PSI}{GPM} \right) \times v (SUS) \times \frac{\rho}{0.876} \left(\frac{kg}{dm^3} \right)$$

For ease of calculation our Filter Selection tool is available online at www.eatonpowersource.com/calculators/filtration/

Material gradient coefficients (MSK) for filter elements

The material gradient coefficients in psi/gpm apply to mineral oil (HLP) with a density of 0.876 kg/dm³ and a kinematic viscosity of 139 SUS (30 mm²/s). The pressure drop changes proportionally to the change in kinematic viscosity and density.

NF	VG				
	3VG	6VG	10VG	16VG	25VG
631	0.356	0.247	0.158	0.138	0.094

$\Delta p = f(Q)$ – characteristics according to ISO 3968

The pressure drop characteristics apply to mineral oil (HLP) with a density of 0.876 kg/dm³. The pressure drop changes proportionally to the density.

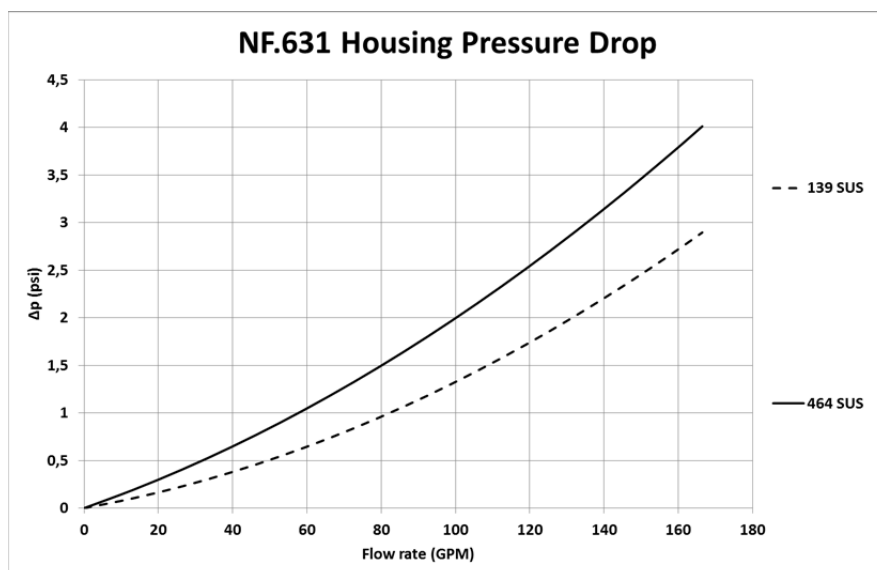

Symbols:

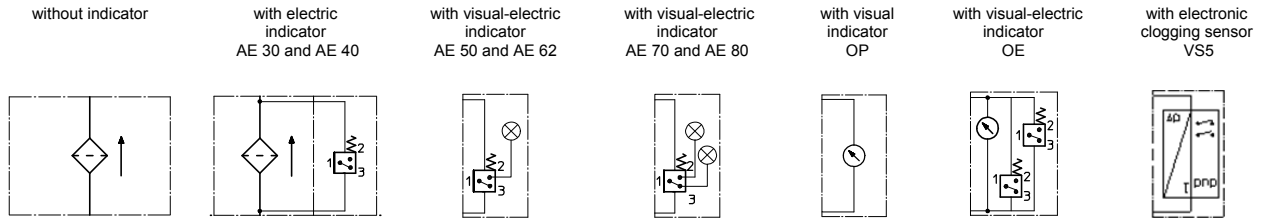

Spare parts:

item	qty.	designation	dimension	article-no.
1	1	filter element	01NR.630...	
2	1	filter cover	30600-3	315492
3	1	mini-measuring connection	MA.1.St	305453
4	2	screw plug	1/2 BSPP	304678
5	1	straining screw	30595-3	316312
6	1	O-ring	140 x 6	315392 (NBR) 316322 (FPM)
7	2	O-ring	70 x 4	306253 (NBR) 310280 (FPM)
8	1	O-ring	22 x 3	304387 (NBR) 304931 (FPM)
9	1	clogging indicator, visual	OP	see sheet-no. 1628
10	1	clogging indicator, visual-electric	OE	see sheet-no. 1628
11	1	clogging indicator, visual-electric	AE	see sheet-no. 1609
12	1	clogging sensor, electronic	VS5	see sheet-no. 1641
13	2	O-ring	14 x 2	304342 (NBR) 304722 (FPM)
14	2	screw plug	1/8 BSPP	304791
15	1	screw plug	1/8 BSPP	305496
16	1	O-ring	153 x 4	320763 (NBR) 322368 (FPM)

item 14 execution only without clogging indicator or clogging sensor

Test methods:

Filter elements are tested according to the following ISO standards:

ISO 2941	Verification of collapse/burst resistance
ISO 2942	Verification of fabrication integrity
ISO 2943	Verification of material compatibility with fluids
ISO 3723	Method for end load test
ISO 3724	Verification of flow fatigue characteristics
ISO 3968	Evaluation of pressure drop versus flow characteristics
ISO 16889	Multi-pass method for evaluating filtration performance

North America

44 Apple Street
Tinton Falls, NJ 07724
Toll Free: 800 656-3344
(North America only)
Tel: +1 732 212-4700

Europe/Africa/Middle East

Auf der Heide 2
53947 Nettersheim, Germany
Tel: +49 2486 809-0

Friedensstraße 41
68804 Altlußheim, Germany
Tel: +49 6205 2094-0

An den Nahewiesen 24
55450 Langerlonsheim, Germany
Tel: +49 6704 204-0

China

No. 3, Lane 280,
Linhong Road
Changning District, 200335
Shanghai, P.R. China
Tel: +86 21 5200-0099

Singapore

4 Loyang Lane #04-01/02
Singapore 508914
Tel: +65 6825-1668

Brazil

Av. Julia Gaioli, 474 – Bonsucesso
07251-500 – Guarulhos, Brazil
Tel: +55 11 2465-8822

**For more information, please
email us at filtration@eaton.com
or visit www.eaton.com/filtration**

© 2015 Eaton. All rights reserved. All trademarks and registered trademarks are the property of their respective owners. All information and recommendations appearing in this brochure concerning the use of products described herein are based on tests believed to be reliable. However, it is the user's responsibility to determine the suitability for his own use of such products. Since the actual use by others is beyond our control, no guarantee, expressed or implied, is made by Eaton as to the effects of such use or the results to be obtained. Eaton assumes no liability arising out of the use by others of such products. Nor is the information herein to be construed as absolutely complete, since additional information may be necessary or desirable when particular or exceptional conditions or circumstances exist or because of applicable laws or government regulations.

Series NF 1000 232 PSI

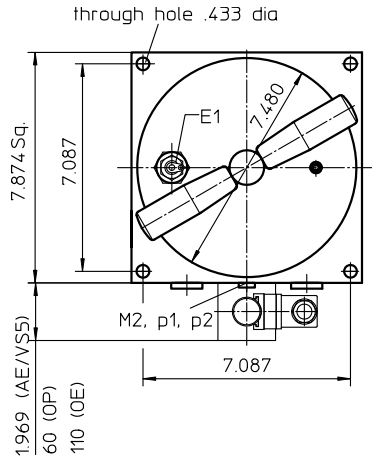

- M2, p1 = measure connection dirt side
- M2, p2 = measure connection clean side
- E1 = air bleeding dirt side
- E2 = drain dirt side
- E3 = drain clean side

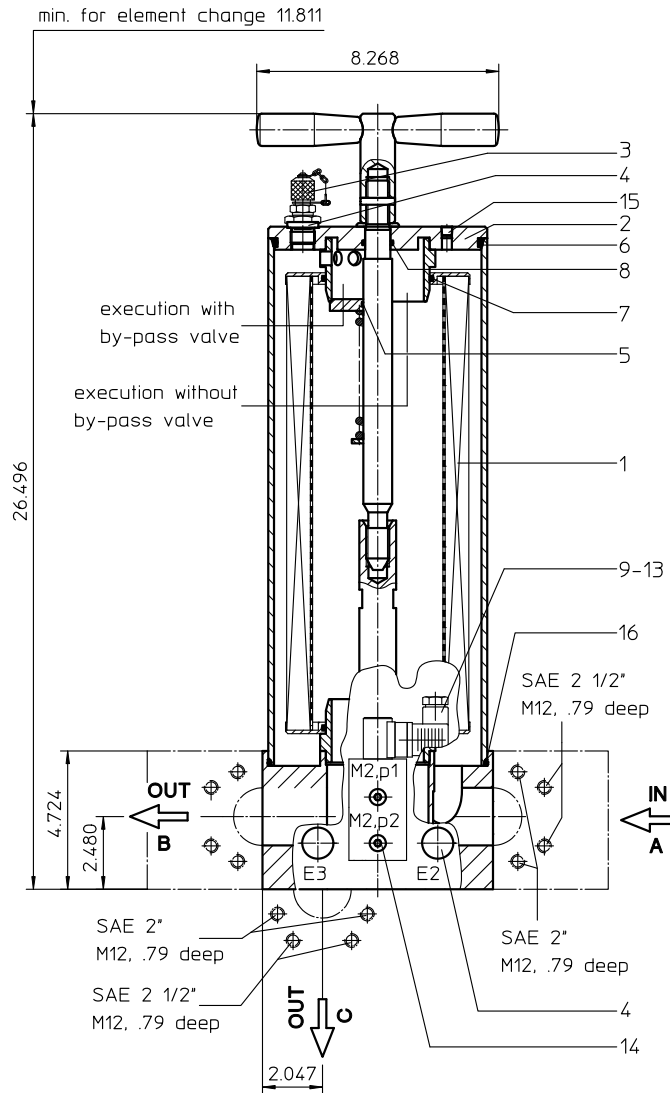

Weight: approx. 51 lbs.

Dimensions: inches

Designs and performance values are subject to change.



Powering Business Worldwide

Offline Filter

Series NF 1000

232 PSI

Description:

The offline filter series NF is used for fine filtration of hydraulic or lubrication circuits. This filter is designed to be installed in an offline filtration circuit, independent of the main circuit. This filter is designed to have a high dirt holding capacity which will provide a long service life.

The filter is flanged mounted to the line.

The filter element consists of star-shaped, pleated filter material, which is supported on the inside by a perforated core tube and is bonded to the end caps with a high-quality adhesive. The flow direction is from outside to inside. Filter elements are available down to 5 $\mu\text{m(c)}$. Finer filtration is available upon request.

Changing the elements is possible without tools. Release the key handle and remove the cover to access the elements.

Eaton filter elements are known for high intrinsic stability and an excellent filtration capability, a high dirt-retaining capacity and a long service life.

1. Type index:

1.1. Complete filter: (ordering example)

NF. 1000. 10VG. 10. B. P. -. FS. 3. -. -. AE

1	2	3	4	5	6	7	8	9	10	11	12
---	---	---	---	---	---	---	---	---	----	----	----

- 1 | **series:**
NF = offline filter
- 2 | **nominal size:** 1000
- 3 | **filter-material and filter-fineness:**
80G, 40G, 25G, 10G stainless steel wire mesh
25VG, 16VG, 10VG, 6VG, 3VG microglass
10WVG, 3WVG watersorp-filter element
- 4 | **filter element collapse rating:**
10 = Δp 145 PSI
- 5 | **filter element design:**
B = both sides open
- 6 | **sealing material:**
P = Nitrile (NBR)
V = Viton (FPM)
- 7 | **filter element specification:** (see catalog)
- = standard
VA = stainless steel
IS06 = for HFC applications, see sheet-no. 31601
- 8 | **connection:**
FS = SAE-flange 3000 PSI
- 9 | **no. of version:**

version	connection		
	A connection size	B connection size	C connection size
1	8	8	-
2	8	8	8
3	9	9	-
4	9	9	9

connection size: 8 = 2"
9 = 2 1/2"
- = without connection

- 10 | **filter housing specification:** (see catalog)
- = standard
IS06 = for HFC applications, see sheet-no. 31605
- 11 | **internal valve:**
- = without
S1 = with by-pass valve Δp 51 PSI
- 12 | **clogging indicator or clogging sensor :**
- = without
AE = visual-electrical, see sheet-no. 1609
OP = visual, see sheet-no. 1628
OE = visual-electrical, see sheet-no. 1628
VS5 = electrical, see sheet-no. 1641

To add an indicator to your filter, use the corresponding indicator data sheet to find the indicator details and add them to the filter assembly model code.

1.2. Filter element: (ordering example)

01NR. 1000. 10VG. 10. B. P. -

1	2	3	4	5	6	7
---	---	---	---	---	---	---

- 1 | **series:**
01NR. = standard return line filter element according to DIN 24550, T4
- 2 | **nominal size:** 1000
- 3 | - 7 | see type index-complete filter

Accessories:

- gauge port- and bleeder connection, see sheet-no. 1650
- drain- and bleeder-connections, see sheet-no. 1651
- counter flange, see sheet-no. 1652

Technical data:

design temperature:	14 °F to +212 °F
operating temperature:	14 °F to +176 °F
operating medium:	mineral oil, other media on request
max. operating pressure:	232 PSI
test pressure:	333 PSI
process connection:	SAE-flange 3000 PSI
housing material:	aluminium forging alloy
sealing material:	Nitrile (NBR) or Viton (FPM), other materials on request
installation position:	vertical
measure connections:	BSPP ¼
drain- and bleeder connections:	BSPP ½
volume tank:	3.0 Gal.

Classified under the Pressure Equipment Directive 2014/68/EC for mineral oil (fluid group 2), Article 4, Para. 3.
 Classified under ATEX Directive 2014/34/EC according to specific application (see questionnaire sheet-no. 34279-4).

Pressure drop flow curves:

Filter calculation/sizing

The pressure drop of the assembly at a given flow rate Q is the sum of the housing Δp and the element Δp and is calculated as follows:

$$\Delta p_{assembly} = \Delta p_{housing} + \Delta p_{element}$$

$$\Delta p_{housing} = (\text{see } \Delta p = f(Q) \text{ - characteristics})$$

$$\Delta p_{element} (PSI) = Q (GPM) \times \frac{MSK}{1000} \left(\frac{PSI}{GPM} \right) \times \nu (SUS) \times \frac{\rho}{0.876} \left(\frac{kg}{dm^3} \right)$$

For ease of calculation our Filter Selection tool is available online at www.eatonpowersource.com/calculators/filtration/

Material gradient coefficients (MSK) for filter elements

The material gradient coefficients in psi/gpm apply to mineral oil (HLP) with a density of 0.876 kg/dm³ and a kinematic viscosity of 139 SUS (30 mm²/s). The pressure drop changes proportionally to the change in kinematic viscosity and density.

NF	VG				
	3VG	6VG	10VG	16VG	25VG
1000	0.237	0.165	0.105	0.092	0.063

$\Delta p = f(Q)$ – characteristics according to ISO 3968

The pressure drop characteristics apply to mineral oil (HLP) with a density of 0.876 kg/dm³. The pressure drop changes proportionally to the density.

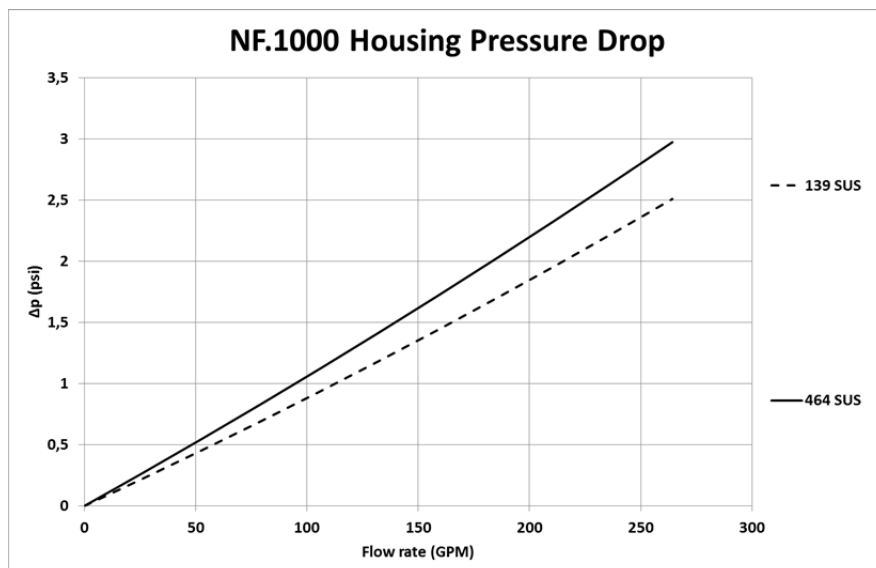

Symbols:

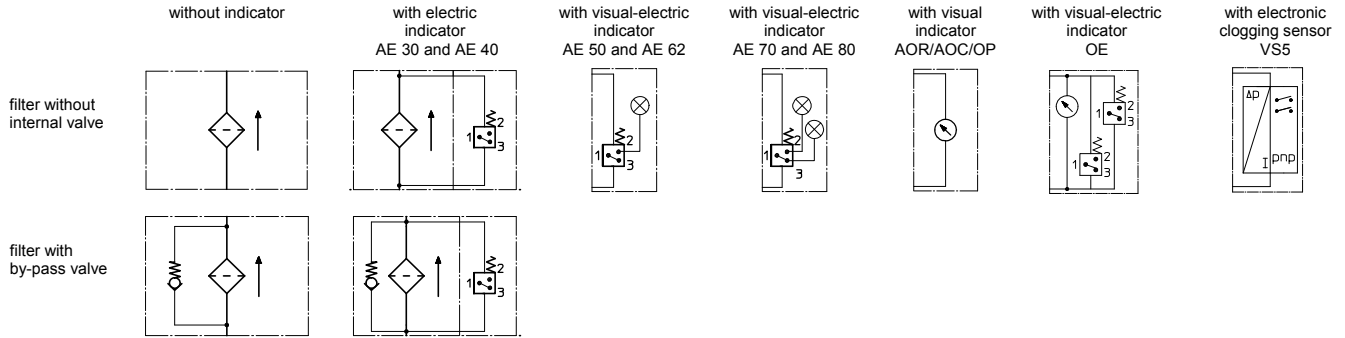

Spare parts:

item	qty.	designation	dimension	article-no.
1	1	filter element	01NR.1000...	
2	1	filter cover without by-pass valve	31065-3	
	1	filter cover with by-pass valve S1	31461-3	
3	1	mini-measuring connection	MA.3.ST	308630
4	3	screw plug	1/2 BSPP	304678
5	1	O-ring (only with by-pass valve)	22 x 3	304387 (NBR) 304931 (FPM)
6	1	O-ring	170 x 6	304799 (NBR) 306529 (FPM)
7	2	O-ring	90 x 4	306941(NBR) 307031(FPM)
8	1	O-ring	22 x 3	304387(NBR) 304931(FPM)
9	1	clogging indicator, visual	OP	see sheet-no. 1628
10	1	clogging indicator, visual-electric	OE	see sheet-no. 1628
11	1	clogging indicator, visual-electric	AE	see sheet-no. 1609
12	1	clogging sensor, electronic	VS5	see sheet-no. 1641
13	2	O-ring	14 x 2	304342 (NBR) 304722 (FPM)
14	2	screw plug	1/8 BSPP	304791
15	1	screw plug	1/8 BSPP	305496
16	1	O-ring	183 x 4	3337005(NBR) 337006(FPM)

item 14 execution only without clogging indicator or clogging sensor

Test methods:

Filter elements are tested according to the following ISO standards:

ISO 2941	Verification of collapse/burst resistance
ISO 2942	Verification of fabrication integrity
ISO 2943	Verification of material compatibility with fluids
ISO 3723	Method for end load test
ISO 3724	Verification of flow fatigue characteristics
ISO 3968	Evaluation of pressure drop versus flow characteristics
ISO 16889	Multi-pass method for evaluating filtration performance

North America

44 Apple Street
Tinton Falls, NJ 07724
Toll Free: 800 656-3344
(North America only)
Tel: +1 732 212-4700

Europe/Africa/Middle East

Auf der Heide 2
53947 Nettersheim, Germany
Tel: +49 2486 809-0

Friedensstraße 41
68804 Altlußheim, Germany
Tel: +49 6205 2094-0

An den Nahewiesen 24
55450 Langenlonsheim, Germany
Tel: +49 6704 204-0

China

No. 3, Lane 280,
Linhong Road
Changning District, 200335
Shanghai, P.R. China
Tel: +86 21 5200-0099

Singapore

4 Loyang Lane #04-01/02
Singapore 508914
Tel: +65 6825-1668

Brazil

Av. Julia Gaioli, 474 – Bonsucesso
07251-500 – Guarulhos, Brazil
Tel: +55 11 2465-8822

For more information, please

email us at filtration@eaton.com
or visit www.eaton.com/filtration

© 2015 Eaton. All rights reserved. All trademarks and registered trademarks are the property of their respective owners. All information and recommendations appearing in this brochure concerning the use of products described herein are based on tests believed to be reliable. However, it is the user's responsibility to determine the suitability for his own use of such products. Since the actual use by others is beyond our control, no guarantee, expressed or implied, is made by Eaton as to the effects of such use or the results to be obtained. Eaton assumes no liability arising out of the use by others of such products. Nor is the information herein to be construed as absolutely complete, since additional information may be necessary or desirable when particular or exceptional conditions or circumstances exist or because of applicable laws or government regulations.