

CARATTERISTICHE

Luce nominale
 Portata min/max
 Pressione max. di picco
 Pressione max. di taratura
 Rapporto di pilotaggio standard
 Temperatura ambiente
 Temperatura olio
 Filtraggio consigliato
 Coppia di serraggio
 Peso

DN 4
1/25 l/min - 0.15/6.6 GPM
450 bar - 6525 PSI
350 bar - 5075 PSI
Vedi tab. / See tab.
-30°C + 50°C
-30°C + 80°C
30 micron
76÷82 Nm
0.300 Kg

PERFORMANCE

Rated size
 Min/max flow-rate
 Max peak pressure
 Max setting pressure
 Standard pilot ratio
 Room temperature
 Oil temperature
 Recommended filtration
 Tightening torque
 Weight

NOTE:

La taratura deve essere **1.3** volte maggiore della pressione indotta dal carico.

Valve should be set at **1.3** times load induced pressure.

ESEMPIO/EXAMPLE:

Pressione di lavoro max:

Max working pressure:

350 bar / 1.3 = 270 bar

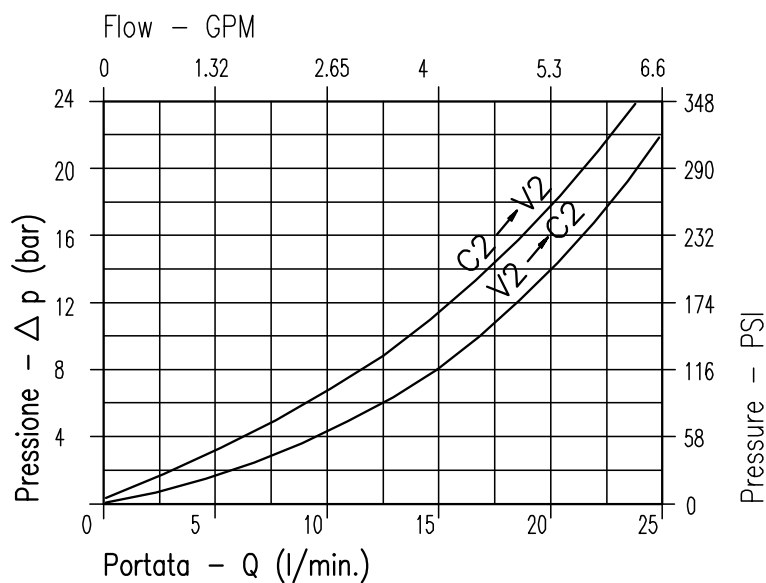

Viscosità olio 46 cSt a 50°C
Oil viscosity 46 cSt at 50°C

VALVOLA BILANCIAMENTO, BLOCCO E CONTROLLO MOVIMENTO A CARTUCCIA CARTRIDGE COUNTERBALANCE VALVES WITHOUT BODY

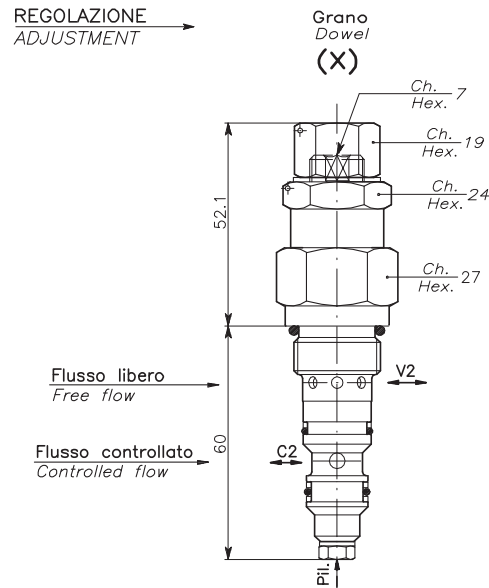

CAVITÀ
CAVITY

CE.120.N

ESEMPIO TIPICO DI CIRCUITO
TYPICAL CIRCUIT EXAMPLE

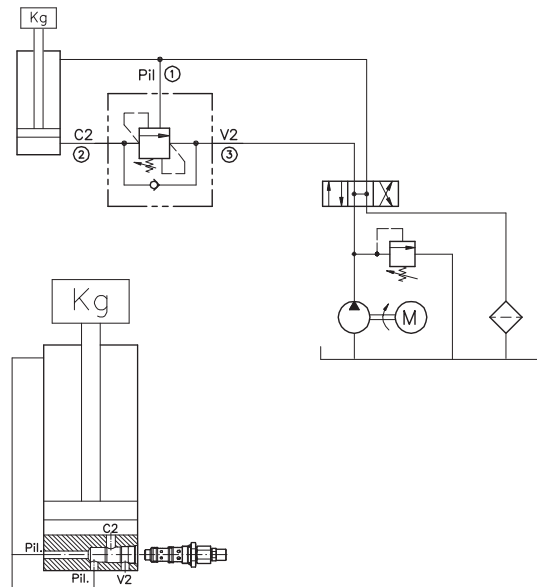
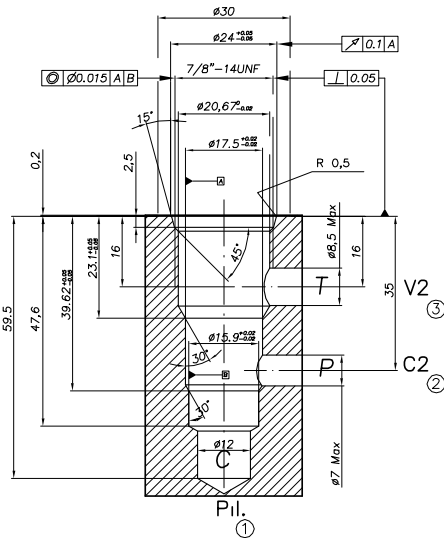

Si raccomanda l'esatta esecuzione della sede
The valve seat should be perfectly tooled

CODICE DI ORDINAZIONE HOW TO ORDER

001.620 . 0 X 0

Campo taratura / Setting range				Rapporto di pilotaggio Pilot ratios		Regolazione Adjustment	
620		635		O	4: 1	X	Grano - Dowel
Campo taratura 30÷220 bar (molla colore verde) Setting range 30÷220 bar (green spring)		Campo taratura 60÷350 bar (molla colore giallo) Setting range 60÷350 bar (yellow spring)		F	7: 1		
Taratura standard (Q=5 l/1')	Incr. press. - bar giro/vite	Taratura standard (Q=5 l/1')	Incr. press. - bar giro/vite				
Std. bar setting (Q=5 l/1')	Pressure rise - turn of screw	Std. bar setting (Q=5 l/1')	Pressure rise - turn of screw				
180 bar	(45)	250 bar	(75)				