



VAVLOLE DI RITEGNO

FD

CHECK-Q-METER

CHECK-Q-METERS ARE USED IN HYDRAULIC SYSTEMS TO INFLUENCE THE SPEEDS OF HYDRAULIC MOTORS AND CYLINDERS INDEPENDENT OF THE LOAD (PREVENTS RUNNING AWAY). IN ADDITION THERE IS AN ISOLATOR FUNCTION FOR PIPE BURST SAFETY.

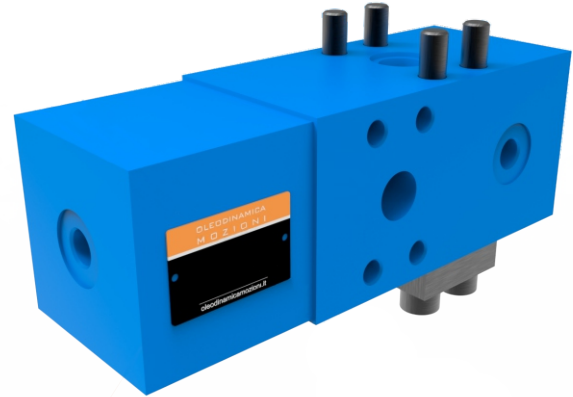

TECHNICAL DATA

SIZE	12, 16, 25, 32	
MAX. FLOW RATE (L/MIN)	80, 200, 320, 560	
OPERATING PRESSURE (MPA)	A, X PORTS	35
	B PORT	42
FLUID TEMPERATURE (°C)	-20 - 80	
FILTRATION ACCURACY (µM)	10	
WEIGHT (KG)	SEE PAGES 5 - 8	
VALVE BODY (MATERIAL)	CASTING PHOSPHATING SURFACE	



CHARACTERISTIC CURVES

ΔP -Q CHARACTERISTIC CURVES

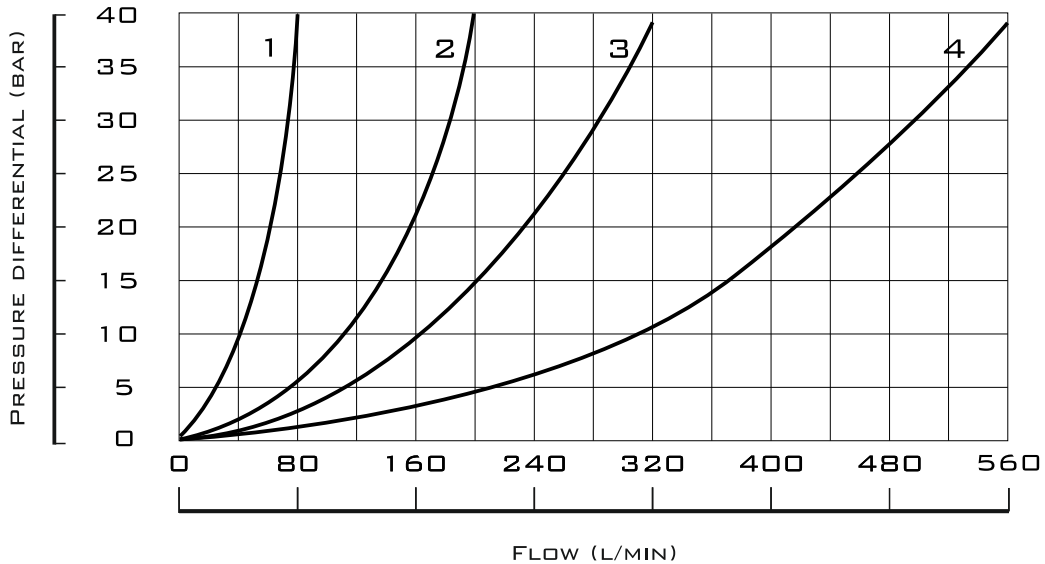

MEASURED AT THROTTLE POSITION: B → A
 THROTTLE FULLY OPEN ($P_x =$ UP TO 70 BAR)

- 1 - SIZE 12
- 2 - SIZE 16
- 3 - SIZE 25
- 4 - SIZE 32

ΔP -Q CHARACTERISTIC CURVES

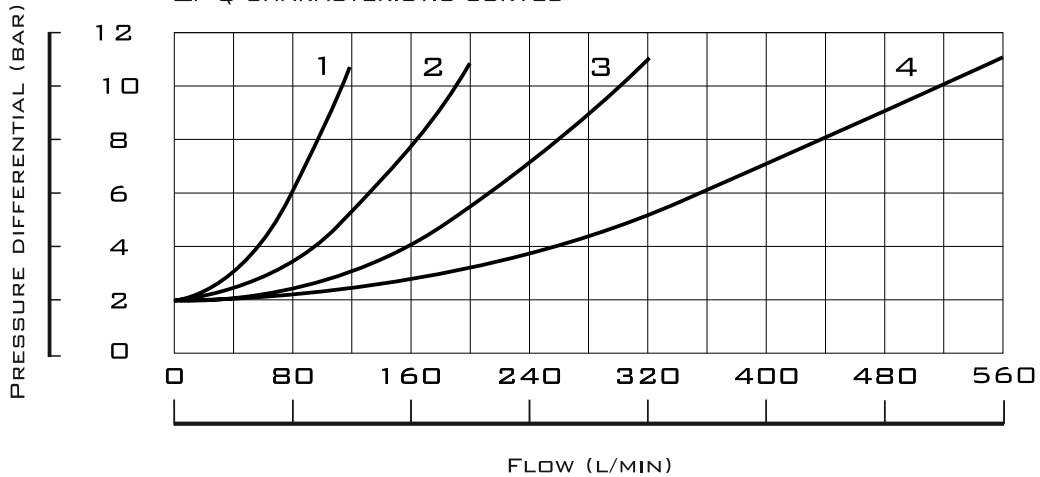

MEASURED VIA THE CHECK VALVE: A → B

- 1 - SIZE 12
- 2 - SIZE 16
- 3 - SIZE 25
- 4 - SIZE 32

NOTE
 CHARACTERISTIC CURVES MEASURED AT $V = 41 \text{ mm}^2$ AND $\theta = 50^\circ \text{ C}$.



SPOOL SYMBOLS

WITHOUT SECONDARY PRESSURE RELIEF VALVE

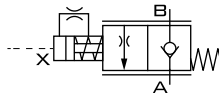

VALVE TYPE:
 FD 12 KA 2X/B03..
 FD 16 KA 2X/B03..
 FD 25 KA 2X/B04..
 FD 32 KA 2X/B06..

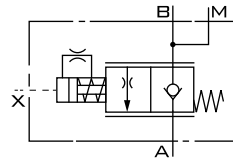

VALVE TYPE:
 FD 12 PA 2X/B03.. FD 12 FA 2X/B03..
 FD 16 PA 2X/B03.. FD 16 FA 2X/B03..
 FD 25 PA 2X/B04.. FD 25 FA 2X/B04..
 FD 32 PA 2X/B06.. FD 32 FA 2X/B06..

WITH SECONDARY PRESSURE RELIEF VALVE

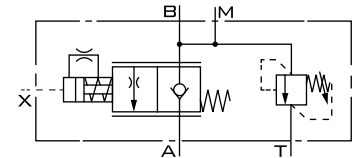

VALVE TYPE:
 FD 12 FB 2X/.B03..
 FD 16 FB 2X/.B03..
 FD 25 FB 2X/.B04..
 FD 32 FB 2X/.B06..

PORTS

A	CONTROL BLOCK
B	CONSUMER
T	TANK
X	CONTROL PORT
M	MEASURING PORT

THE CHECK-Q-METER COMPRISES BASICALLY OF THE HOUSING (1), MAIN POPPET (2), PILOT PART (3), PILOT SPOOL (4), DAMPING SPOOL (5) UND PILOT DAMPING (6).

LIFTING THE LOAD

WITH FREE-FLOW FROM A TO B THE MAIN SPOOL (2) IS OPENED. IF THE LOAD PRESSURE FAILS (E.G. PIPE BREAK BETWEEN THE DIRECTIONAL VALVE AND PORTS A) THEN THE MAIN SPOOL (2) IMMEDIATELY CLOSES.

THIS FUNCTION IS ACHIEVED BY THE CONNECTION OF THE LOAD SIDE (7) WITH SPRING CHAMBER (8).

LOWERING THE LOAD (CIRCUIT EXAMPLES)

THE DIRECTION OF FLOW IS FROM B TO A. PORT A IS CONNECTED TO TANK VIA THE DIRECTIONAL VALVE. THE PISTON ROD SIDE OF THE CYLINDER HAS A FLOW APPLIED WHICH CORRESPONDS TO THE WORKING CONDITIONS. THE RELATIONSHIP BETWEEN THE CONTROL PRESSURE AT PORT X AND THE LOAD PRESSURE AT PORT B = 1 : 20. WHEN THE CONTROL PRESSURE IS REACHED THE PRE-OPENING OF THE MAIN SPOOL TAKES PLACE. VIA THE CONTROL SPOOL (4) THE PILOT STAGE (3) IS LIFTED OFF ITS SEAT AND CHAMBER (8) IS DECOMPRESSED VIA THIS DRILLING AND PORT A TO TANK. AT THE SAME TIME THE LOAD PRESSURE IN PORT B IS NO LONGER APPLIED TO CHAMBER (8), WITHIN THE MAIN SPOOL. THE MAIN POPPET (2) IS THEREBY UNLOADED. THE REVERSE SIDE OF THE CONTROL SPOOL (4) AT THE MAIN POPPET (2), LIES AGAINST THE COLLAR OF THE DAMPING SPOOL (5).

THE PRESSURE REQUIRED AT PORT X TO OPEN B TO A IS NOW ONLY INFLUENCED BY THE SPRING IN CHAMBER (9). THE PRESSURE REQUIRED TO BEGIN OPENING THE CONNECTION B TO A IS 20 BAR; TO FULLY OPEN THE CONNECTION UP TO 70 BAR IS REQUIRED DEPENDING ON THE VERSION.

THE OPENING CROSS-SECTION FOR FLOW CONTROL INCREASES PROGRESSIVELY. IT IS CREATED BY THE SUCCESSIVE OPENING OF RADIAL DRILLINGS IN THE BUSH AND THE MAIN POPPET (2) LAND.

THE RELATIONSHIP BETWEEN THE CONTROL PRESSURE, CRACKING PRESSURE AND DIFFERENTIAL PRESSURE DETERMINES THE FLOW TO THE ACTUATOR VIA THE CONNECTION OF B TO A.

THUS UNCONTROLLED RUNNING AWAY OF THE ACTUATOR IS PREVENTED. THE CONTROLLED LOWERING PROCEDURE IS NOT AFFECTED EVEN IF THERE IS A PIPE BURST BETWEEN THE DIRECTIONAL VALVE AND PORT A.

GUIDELINES FOR INFLUENCING THE OPENING AND CLOSING TIMES OF THE CHECK-Q-METER

► THROTTLING OF THE OPENING SEQUENCE IS VIA ORIFICE (6) IN THE CONTROL SPOOL (4) AND BOTH SIDES OF THE DAMPING SPOOL (5). THE ORIFICE (6) IS PROTECTED BY SIEVES.

► THE CLOSING MOVEMENT OF THE CHECK-Q-METER IS VIRTUALLY UN-THROTTLED.

► WHEN BEING USED IN CONJUNCTION WITH CYLINDERS THE CONTROL LINE TO PORT X CAN BE FITTED WITH A THROTTLE CHECK VALVE (METER-OUT CONTROL) TO INFLUENCE THE CLOSING SEQUENCE.

► WHEN BEING USED IN CONJUNCTION WITH MOTORS A THROTTLE CHECK VALVE SHOULD NOT BE FITTED IN THE CONTROL LINE TO PORT X. IN THIS CASE IT IS RECOMMENDED THAT THE CONTROL TIMES OF THE DIRECTIONAL VALVE ARE INFLUENCED.

CROSS SECTION

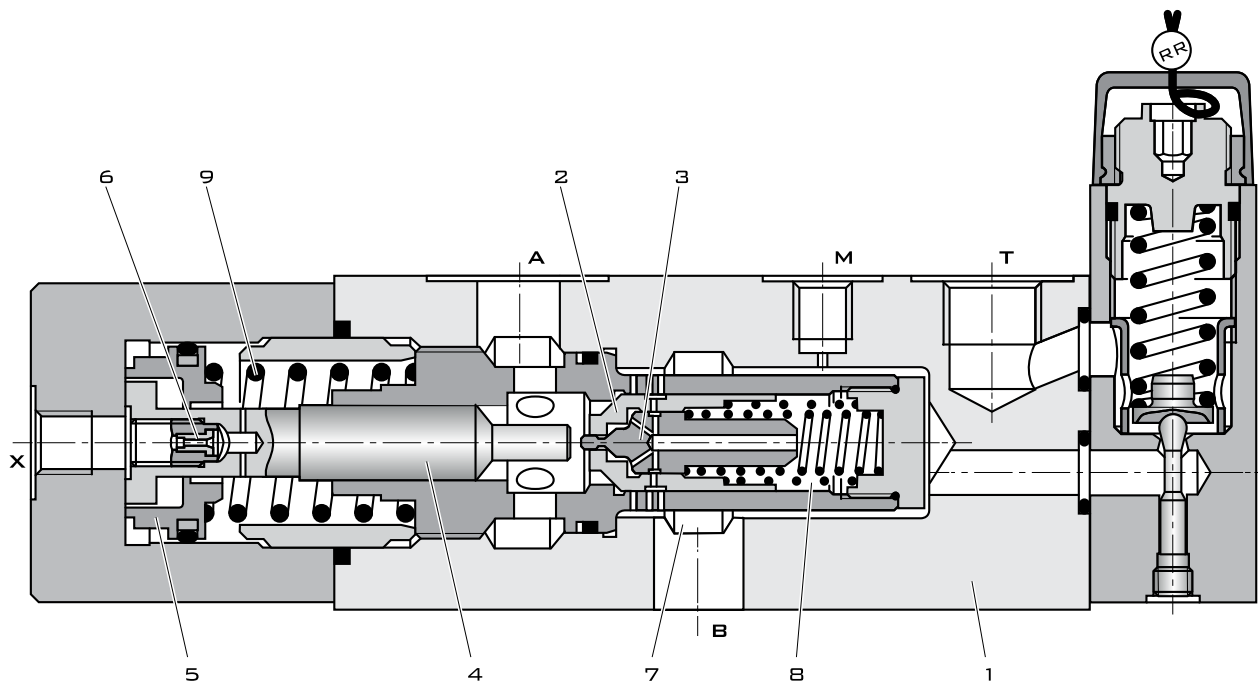

- 1 HOUSING
- 2 MAIN POPPET
- 3 PILOT PART
- 4 PILOT SPOOL
- 5 DAMPING SPOOL
- 6 PILOT DAMPING (ORIFICE)
- 7 LOAD SIDE
- 8 SPRING CHAMBER
- 9 SPRING

FD...FB2X/...VO 1

FD VALVE FOR MANIFOLD MOUNTING (VERSION KA)

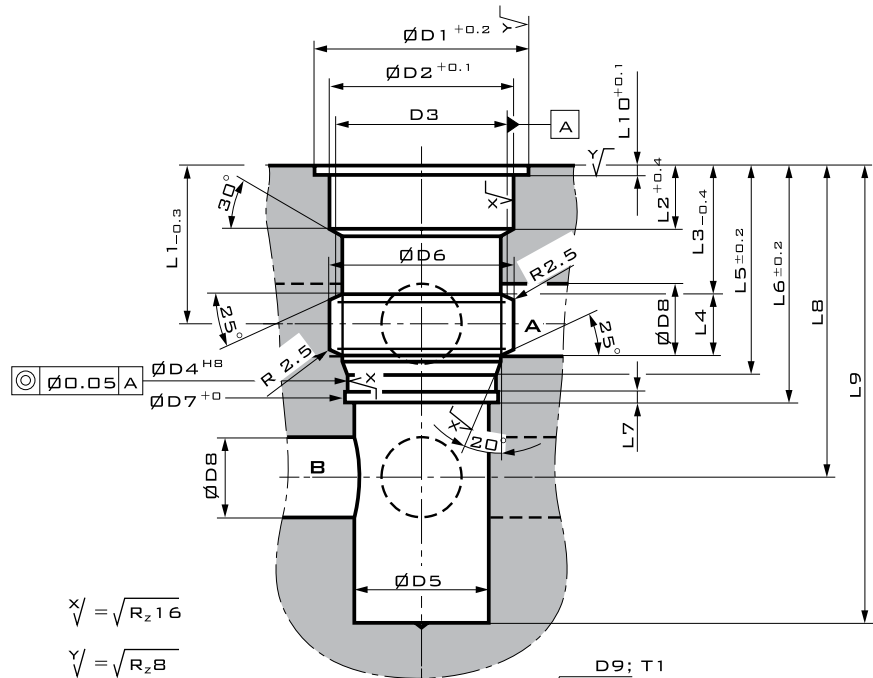
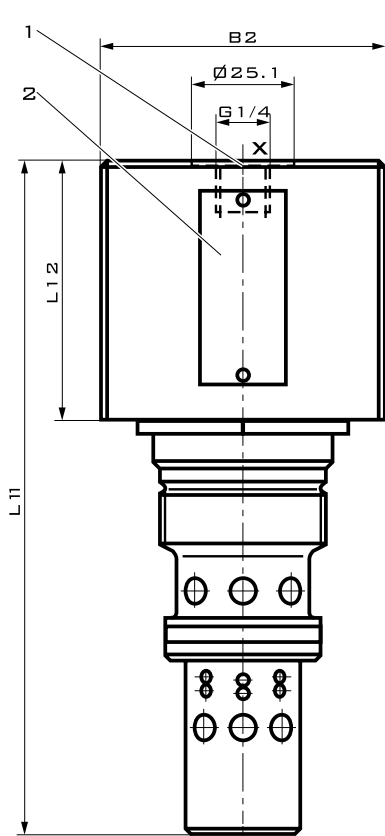

$$X/\sqrt{R_2} = 16$$

$$X/\sqrt{R_2} = 8$$

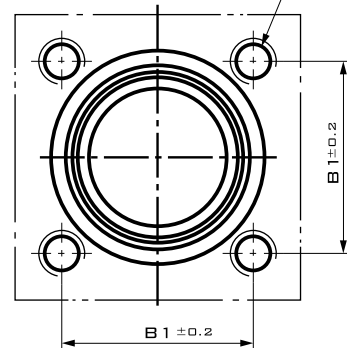

1 CONTROL PORT
2 NAME PLATE

PORTS A AND B CAN BE OPTIONALLY ARRANGED ABOUT THE CIRCUMFERENCE.

ATTENTION!
THE VALVE FIXING HOLES MUST NOT BE DAMAGED.

TIGHTENING TORQUE M_T OF CARTRIDGE VALVE:

SIZE	M_A [NM]
12, 16	65
25	110
32	270

TYPE	B1	B2	D1	D2	D3	D4	D5	D6	D7	D8	D9	T1	L1	L2	L3	L4	L5	L6
FD 12 KA 2X/...	48	70	54	46	M42 X 2	38	34	46	38.6	16	M10	16	39	16	32	15.5	50.5	60
FD 16 KA 2X/...	48	70	54	46	M42 X 2	38	34	46	38.6	16	M10	16	39	16	32	15.5	50.6	60
FD 25 KA 2X/...	56	80	60	54	M52 X 2	48	40	60	48.6	25	M12	19	50	19	39	22	65	80
FD 32 KA 2X/...	66	95	72	65	M64 X 2	58	52	74	58.6	30	M16	23	52	19	40	25	71	85

TYPE	L7	L8	L9	L10	L11	L12	VALVE FIXING SCREWS	TIGHTENING TORQUE M_T [NM]	WEIGHT [KG]
FD 12 KA 2X/...	3	78	128	2.3	191	65	4 PIECES M10 X 70 DIN 912-10.9	69	2.8
FD 16 KA 2X/...	3	78	128	2.3	191	65	4 PIECES M10 X 70 DIN 912-10.9	69	2.8
FD 25 KA 2X/...	4	105	182	2.3	253	75	4 PIECES M12 X 80 DIN 912-10.9	120	5.6
FD 32 KA 2X/...	4	105	198	2.3	289	94	4 PIECES M16 X 100 DIN 912-10.9	295	7.5

PIPE THREADS G ACCORDING TO ISO 228/1

FD VALVE FOR SAE FLANGE CONNECTIONS, WITHOUT SECONDARY PRESSURE RELIEF VALVE (VERSION FA)

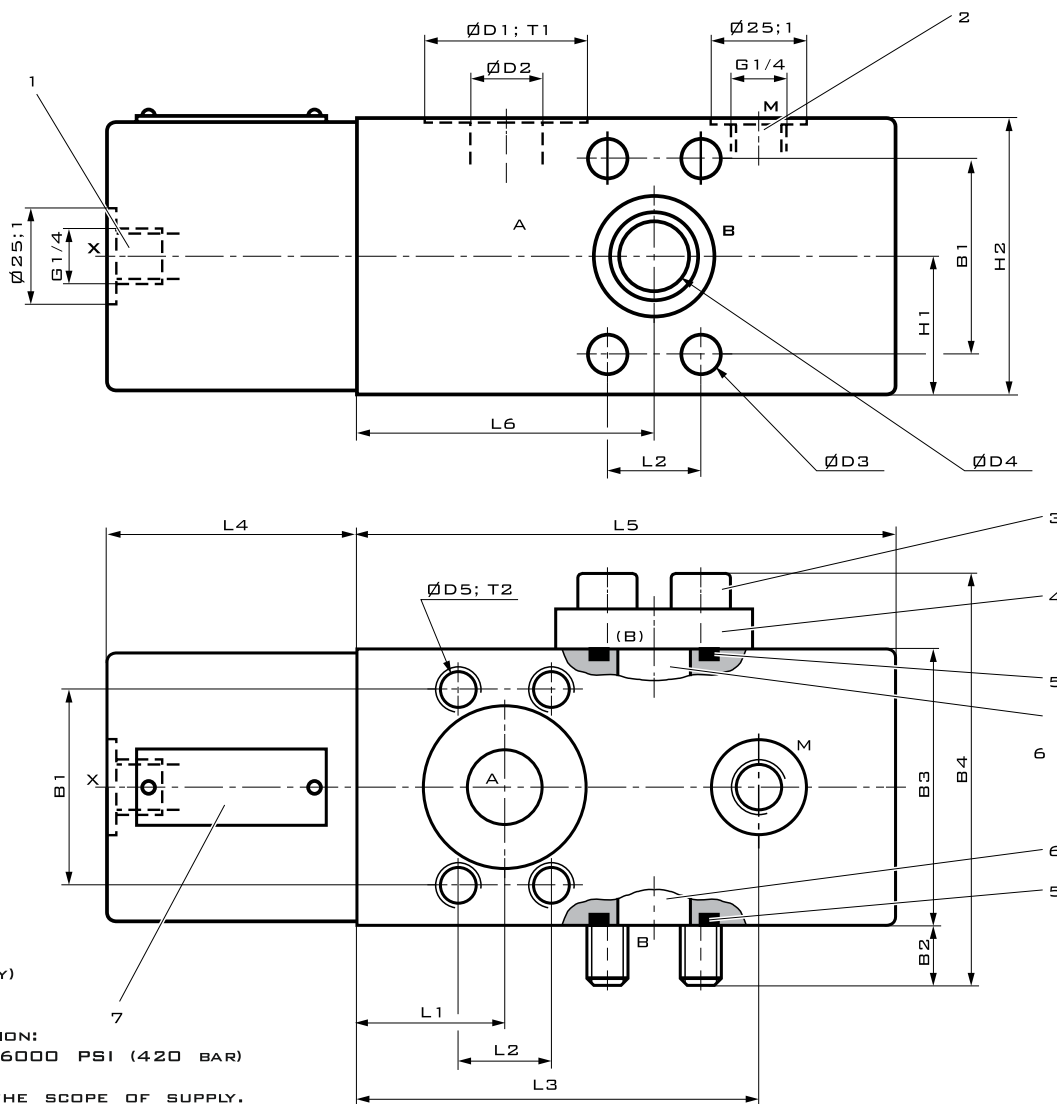

TYPE	B1	B2	B3	B4	D1	D2	D3	D4	D5	H1	H2
FD 12 FA 2X/...	50.8	16.5	72	110	43	18	10.5	18	M10	36	72
FD 16 FA 2X/...	50.8	16.5	72	110	43	18	10.5	18	M10	36	72
FD 25 FA 2X/...	57.2	14.5	90	132	50	25	13.5	25	M12	45	90
FD 32 FA 2X/...	66.7	20	105	154	56	30	15	30	M14	50	105

TYPE	L1	L2	L3	L4	L5	L6	T1	T2	WEIGHT [KG]	O-RING (5)
FD 12 FA 2X/...	39	23.8	105	65	140	78	0.1	15	7	25 × 3.5
FD 16 FA 2X/...	39	23.8	105	65	140	78	0.1	15	7	25 × 3.5
FD 25 FA 2X/...	50	27.8	148	75	200	105	0.1	18	16	32.92 × 3.53
FD 32 FA 2X/...	52	31.6	155	94	215	115	0.1	21	21	37.7 × 3.53

PIPE THREADS G ACCORDING TO ISO 228/1

FD VALVE FOR SAE FLANGE CONNECTIONS, WITH SECONDARY PRESSURE RELIEF VALVE (VERSION FB)

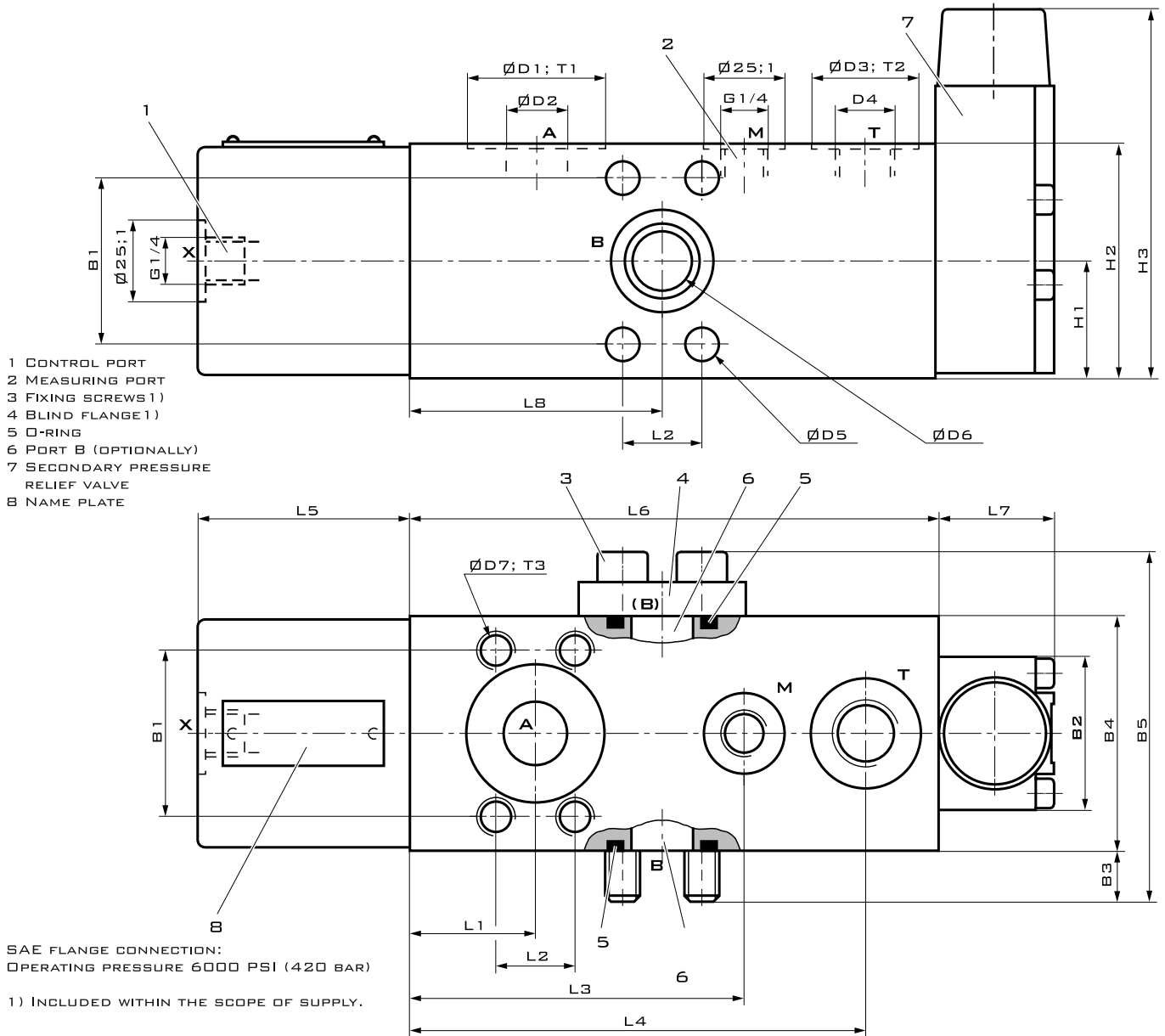

TYPE	B1	B2	B3	B4	B5	D1	D2	D3	D4	D5	D6	D7	H1	H2
FD 12 FB 2X/...	50.8	47	16.5	72	110	43	18	34	G 1/2	10.5	18	M10	36	72
FD 16 FB 2X/...	50.8	47	16.5	72	110	43	18	34	G 1/2	10.5	18	M10	36	72
FD 25 FB 2X/...	57.2	80	14.5	90	132	50	25	42	G 3/4	13.5	25	M12	45	90
FD 32 FB 2X/...	66.7	80	20	105	154	56	30	42	G 3/4	15	30	M14	50	105

TYPE	H3	L1	L2	L3	L4	L5	L6	L7	L8	T1	T2	T3	WEIGHT [KG]	O-RING (5)
FD 12 FB 2X/...	118	39	23.8	105	141.5	65	162	38	78	0.1	1	15	9	25 × 3.5
FD 16 FB 2X/...	118	39	23.8	105	141.5	65	162	38	78	0.1	1	15	9	25 × 3.5
FD 25 FB 2X/...	145	50	27.8	148	198	75	225	50	105	0.1	1	18	18	32.92 × 3.53
FD 32 FB 2X/...	145	52	31.6	155	215	94	240	50	115	0.1	1	21	24	37.7 × 3.53

PIPE THREADS G ACCORDING TO ISO 228/1

FD VALVE FOR SUB-PLATE MOUNTING (VERSION PA)

PORTING PATTERN ACCORDING TO ISO 5781:

SIZE	CODE
12, 16	5781-06-07-0-00
25	5781-08-10-0-00
32	5781-10-13-0-00

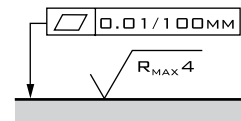

REQUIRED SURFACE FINISH OF MATING PLUGS

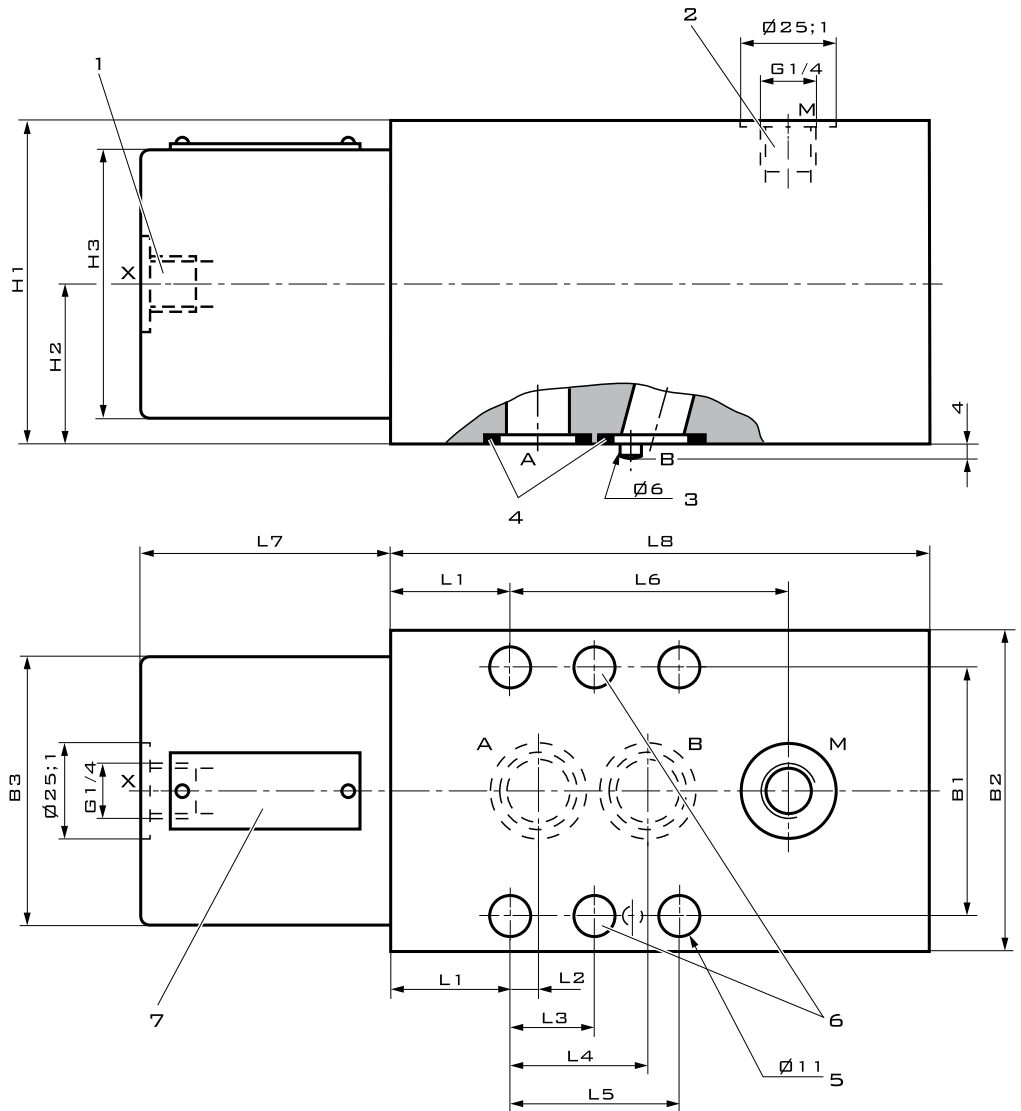

TYPE	B1	B2	B3	H1	H2	H3	L1	L2	L3	L4	L5	L6	L7	L8
FD 12 PA 2X/...	66.7	85	70	85	42.5	70	31.8	7.2	-	35.8	42.9	73.2	65	140
FD 16 PA 2X/...	66.7	85	70	85	42.5	70	31.8	7.2	-	35.8	42.9	73.2	65	140
FD 25 PA 2X/...	79.4	100	80	100	50	80	38.9	11.1	-	49.2	60.3	109.1	75	200
FD 32 PA 2X/...	96.8	120	95	120	60	95	35.3	16.7	42.1	67.5	84.2	119.7	94	215

TYPE	\varnothing A, B	VALVE FIXING SCREWS	TIGHTENING TORQUE M_T [NM]	WEIGHT [KG]	O-RING (4)
FD 12 PA 2X/...	16	4 PIECES M10 X 100 DIN 912-10.9	75	9	21.3 X 2.4
FD 16 PA 2X/...	16	4 PIECES M10 X 100 DIN 912-10.9	75	9	21.3 X 2.4
FD 25 PA 2X/...	22	4 PIECES M10 X 120 DIN 912-10.9	75	18	29.82 X 2.62
FD 32 PA 2X/...	30	6 PIECES M10 X 140 DIN 912-10.9	75	24	27.69 X 3.53

PIPE THREADS G ACCORDING TO ISO 228/1

CIRCUIT EXAMPLES

DIFFERENTIAL CYLINDER

FOR SAFETY REASONS, ALWAYS A CLOSED CENTRE DIRECTIONAL VALVE SHOULD BE USED!

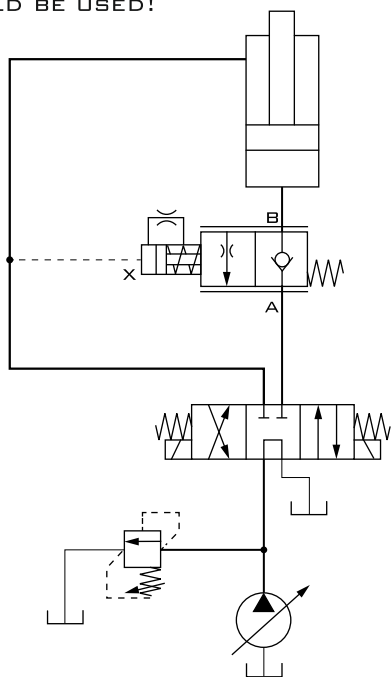

NOTE

TWO SINGLE CHECK-Q-METERS CANNOT BE USED TO CONTROL TWO CYLINDERS WHICH ARE FORCED MECHANICALLY TO MOVE TOGETHER, AS SYNCHRONISATION AND THE SAME PRESSURE CANNOT BE GUARANTEED IN EACH CYLINDER.

THEREFORE, THE CYLINDERS HAVE TO BE EQUIPPED WITH TWO PILOT OPERATED CHECK VALVES, TYPE SL FROM BOSCH REXROTH (SEE DATA SHEET 21460 FOR SIZE 6 OR 21468 FOR SIZE 10 TO 32). THE CHECK-Q-METER IS FITTED IN A COMMON LINE.

IN THIS CASE, THE LOAD PRESSURE MUST NOT EXCEED 200 BAR BECAUSE OF THE OPENING RATIO OF THE SL VALVES!

EXAMPLE:

LOAD PRESSURE AT CYLINDER: 200 BAR
 AREA RATIO SL CHECK VALVE: 1/11
 CRACKING PRESSURE SPRING FD VALVE: 20 BAR

$$\frac{200 \text{ BAR}}{11} = 18.2 \text{ BAR}$$

HYDRAULIC MOTOR

► INTERNAL CONTROL OF THE HOLDING BRAKE: SO THAT THE HOLDING BRAKE CAN OPERATE BOTH OF THE DIRECTION ALL VALVE PORTS HAVE TO BE CONNECTED TO PORT T IN THE NEUTRAL POSITION.

► EXTERNAL CONTROL OF THE HOLDING BRAKE: FOR SAFETY REASONS, IF THE BRAKE IS EXTERNALLY UNLOADED THEN IT IS POSSIBLE TO USE A CLOSED CENTER DIRECTIONAL VALVE FOR THE NEUTRAL POSITION.

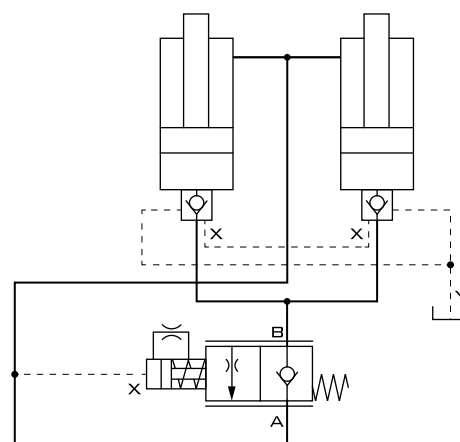
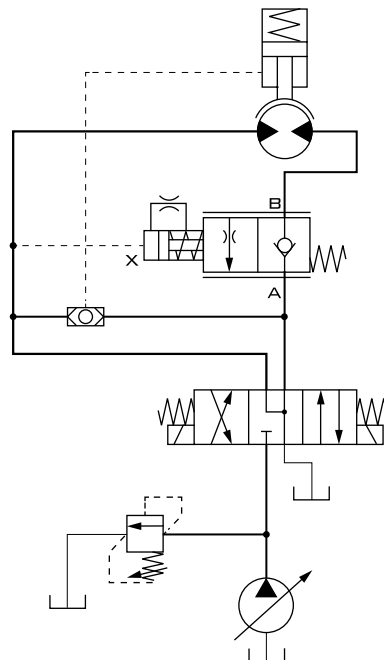

18.2 BAR < 20 BAR
 CRACKING PRESSURE SL VALVE < CRACKING PRESSURE FD VALVE

FD

VAVLOLE DI RITEGNO



CHECK-Q-METER

ORDER CODE

FD 2X / V *

CHECK-Q-METER

12 = SIZE 12
16 = SIZE 16
25 = SIZE 25
32 = SIZE 32

KA = MANIFOLD MOUNTING (CARTRIDGE VALVE)
FA = SAE FLANGE CONNECTIONS WITHOUT SECONDARY PRESSURE RELIEF VALVE
FB = SAE FLANGE CONNECTIONS WITH SECONDARY PRESSURE RELIEF VALVE
PA = SUB-PLATE MOUNTING WITHOUT SECONDARY PRESSURE RELIEF VALVE

20 TO 29 (UNCHANGED INSTALLATION AND CONNECTION DIMENSIONS)

200 = PRESSURE SETTING UP TO 200 BAR
315 = PRESSURE SETTING UP TO 315 BAR
420 = PRESSURE SETTING UP TO 420 BAR

B00 = WITHOUT DRIFICE
B03 = WITH DRIFICE 0.3 MM (SIZES 12 AND 16)
B04 = WITH DRIFICE 0.4 MM (SIZE 25)
B06 = WITH DRIFICE 0.6 MM (SIZE 32)

V = FKM (FLUOROELASTOMER)

FURTHER SPECIFICATIONS IN PLAIN TEXT