

DESCRIPTION

PRESSURE TEST DEVICE IS USED FOR CONTROL OPERATION OF COMPRESSED GASES AND LIQUIDS. TB1.4 SERIES PRESSURE TEST DEVICE HAS FOUR PIECES MANOMETERS. IT CAN BE MEASURED FROM TWO DIFFERENT LINE, AT THE SAME TIME THANKS TO TWO PIECES PRESSURE TEST HOSES. PRODUCT IS SOLID FOR THESE MEASUREMENTS.

APPLICATIONS

- MOBILE HYDRAULICS, HYDRAULICS AND MACHINES
- AUTOMOTIVE SECTOR
- HYDRAULIC PRESS MACHINES
- HEAVY-DUTY MACHINES
- ON VEHICLE SECTOR (CRANE, FIRE TRUCKS, GARBAGE TRUCKS ETC.)

TECHNICAL FEATURES

MODEL	TB1.4
MANOMETER	MANOMETERS WHICH ARE INSIDE OF PRESSURE TEST DEVICE ARE OPTIONALFOR COSTUMERS
PERMITTED FLUID TEMPERATURE	+20°C ... +60°C
MANOMETER TEST GLANDS	TEST GLANDS OF PRESSURE TEST DEVICE: M16X2 - 1/8" BSP HYDRAULIC MANOMETER TEST GLANDS: 2 PIECES M16X2 - 3/8" BSP HYDRAULIC MANOMETER TEST GLANDS: 2 PIECES M16X2 - 1/4" BSP HYDRAULIC MANOMETER TEST GLANDS: 2 PIECES
PRESSURE TEST HOSES	DN2 MANOMETER TEST HOSES M16X2 - 1/4" BSP -200CM 2 PIECES MAX: 630 BAR

NOTE

USER HAS TO SUPPLY ALL SAFETY CONDITIONS TO HAVE BENEFIT FROM PRESSURE TEST DEVICE.

TECHNICAL DIMENSIONS

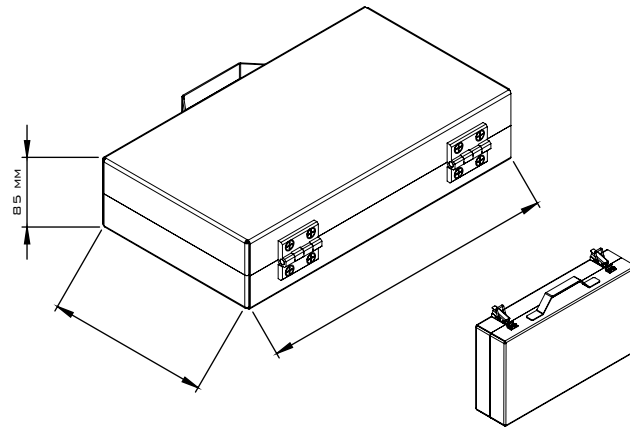

BASIC TEST BOX'S WEIGHT

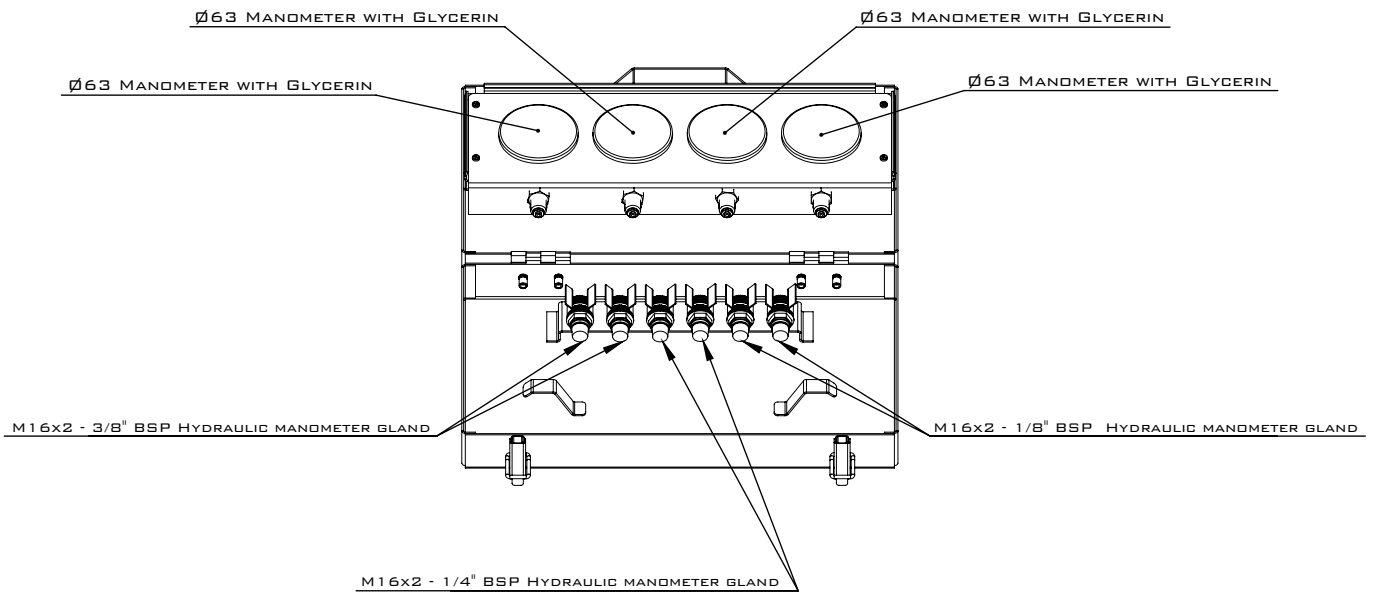

NOTE

- THERE IS 2 PIECES 2 METER HEIGHT PRESSURE TEST HOSE FOR 1 PIECE TB1.4
- PRESSURE TEST HOSE COMPLIES WITH MANOMETER AND MANOMETER TEST GLANDS



TB1.4

PRESSURE TEST DEVICE

ORDER CODE

PLEASE FILL THE "... " BLANK WITH COMPLIED NUMBER TO CREATE ORDER CODE.
MANOMETERS WHICH ARE INSIDE OF PRESSURE TEST DEVICE, ARE PREPARED CUSTOMLY
ACCORDING TO USER'S DESIRE

TB1.4 - ... - ... - ... - ...

- | | |
|----------------|-----------------|
| 1. 0...6 BAR | 7. 0...160 BAR |
| 2. 0...10 BAR | 8. 0...250 BAR |
| 3. 0...25 BAR | 9. 0...315 BAR |
| 4. 0...40 BAR | 10. 0...400 BAR |
| 5. 0...60 BAR | 11. 0...600 BAR |
| 6. 0...100 BAR | |