

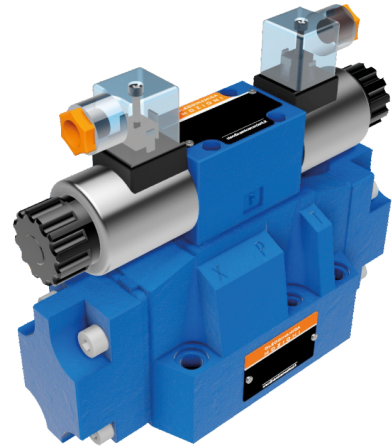

**SOLENOID PILOT OPERATED
DIRECTIONAL CONTROL VALVES**

WEH SERIES ARE SOLENOID PILOT OPERATED
SPOOL TYPE VALVES.
THIS SERIES ARE USED TO CONTROL THE
START, STOP AND DIRECTION OF FLOW.



TECHNICAL DATA

SIZE		16	25	32
MAX. FLOW RATE (L/MIN)		300	650	1100
OPERATING PRESSURE (MPA)	A, B, P PORTS	35		
	T PORT	16		
MIN. PILOT PRESSURE (MPA)		0.45 - 1.3	0.45 - 1	0.45 - 1
WEIGHT (KG)		9.5	18	38.5
VALVE BODY (MATERIAL)		CASTING PHOSPHATING SURFACE		



CHARACTERISTIC CURVES 4WEH16...

ΔP -QV CHARACTERISTIC CURVES

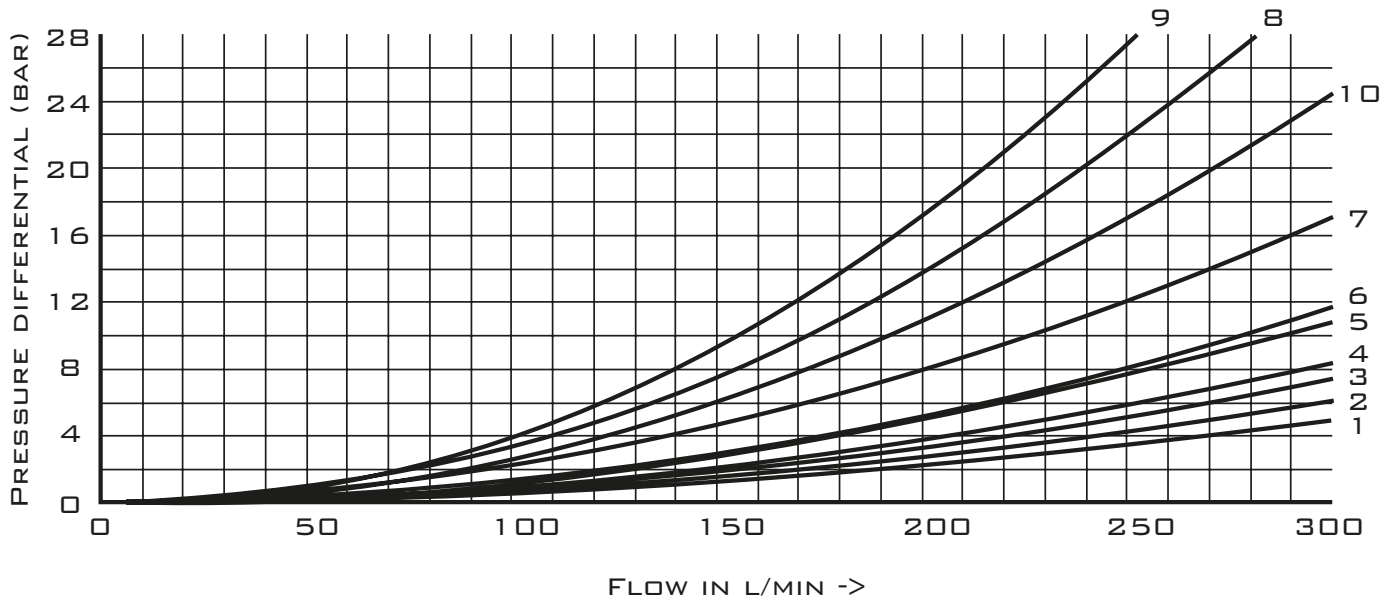

SYMBOL	SPOOL POSITION				ZERO POSITION		
	P — A	P — B	A — T	B — T	P — T	A — T	B — T
D, E, Y	1	1	3	3			
F	1	2	5	5	4	3	—
G	4	1	5	5	7	—	—
C, H	1	1	5	6	2	4	4
K, J	2	2	6	6	—	3	—
L	2	2	5	4	—	3	—
M	1	1	3	4			
P	2	1	3	6	5	—	—
Q	1	1	6	6			
R	2	4	7	—			
S	3	3	3	—	9	—	—
T	4	1	5	5	7	—	—
U	2	2	3	4			6
V, Z	1	1	6	6	10	8	8
W	1	1	3	4			

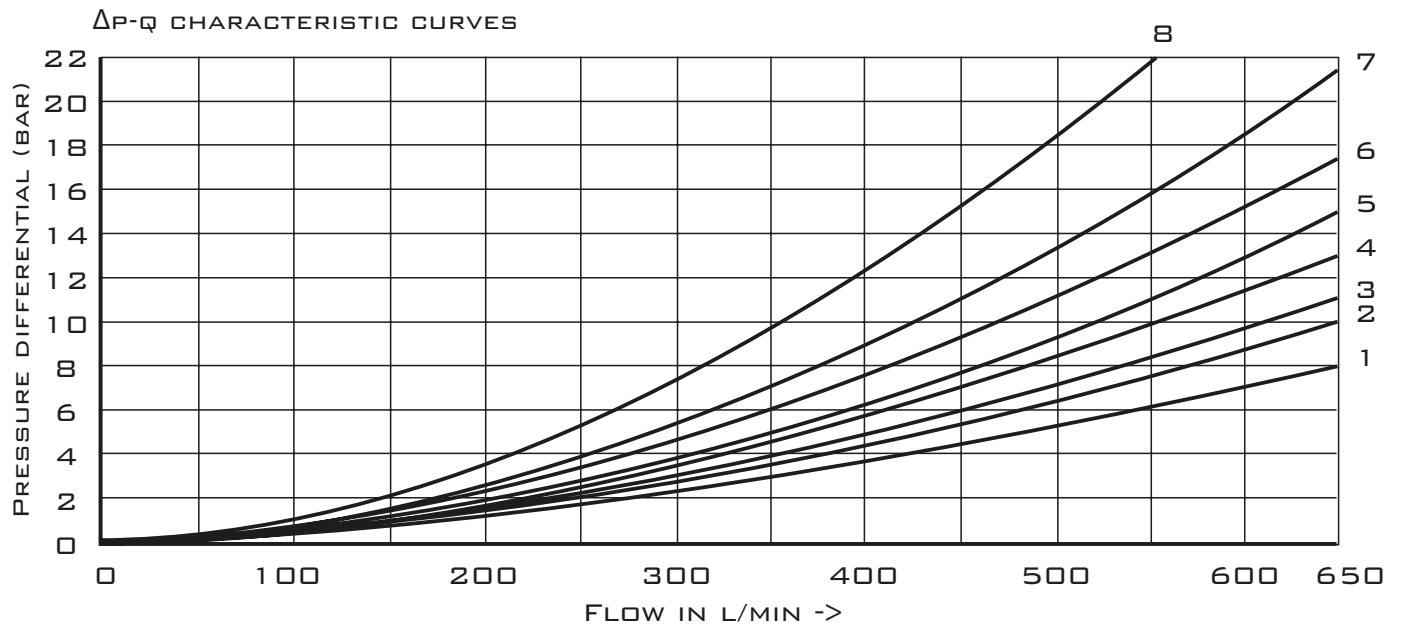
CHARACTERISTIC CURVES 4WEH25...

SYMBOL	SPOOL POSITION				ZERO POSITION		
	P - A	P - B	A - T	B - T	A - T	B - T	P - T
E, Y, D	1	1	3	4			
F	1	1	2	4	2	—	5
G, T	1	1	2	5	—	—	7
H	1	1	2	5	2	2	4
C	1	1	2	5			
J	1	1	2	5	6	5	—
K	1	1	2	5			
L	1	1	2	4	5	—	—
M	1	1	3	4			
P	1	1	3	5	—	3	5
Q	1	1	2	3			
R	1	1	3	—			
U	1	1	2	5	—	5	—
V	1	1	2	5	8	7	—
Z	1	1	2	5			
W	1	1	3	4			

CHARACTERISTIC CURVES 4WEH32...

CHARACTERISTIC CURVES: NG32
(MEASURED WITH HLP46, $t_{oil} = 40 \pm 5 \text{ }^\circ\text{C}$)

$\Delta P-Q_v$ -CHARACTERISTIC CURVES - SYMBOL E, R AND W

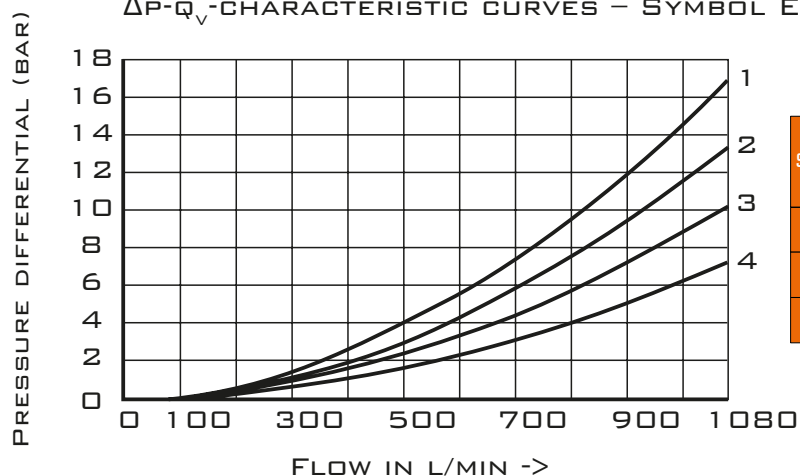

SYMBOL	SPOOL POSITION				
	P - A	P - B	A - T	B - T	B - A
E	4	4	3	2	—
R	4	4	3	—	1
W	4	4	3	2	—

$\Delta P-Q_v$ CHARACTERISTIC CURVES - SYMBOL G AND T

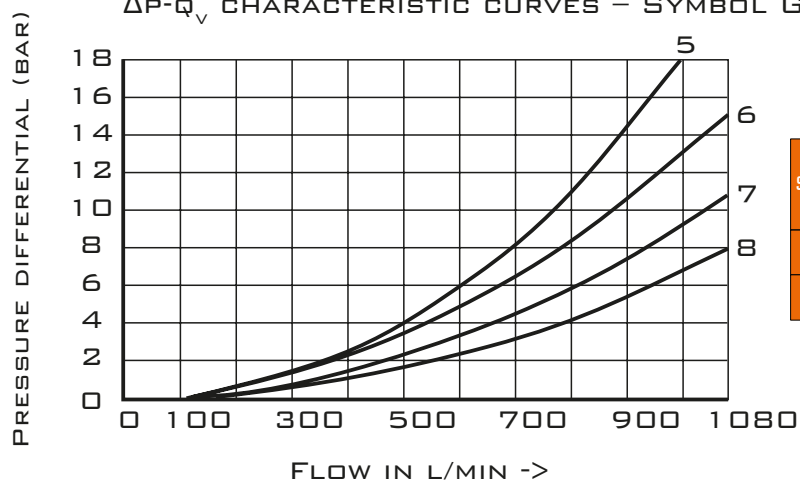

SYMBOL	SPOOL POSITION				
	P - A	P - B	A - T	B - T	P - T
G	7	8	7	5	6
T	7	8	7	5	6

SPOOL SYMBOLS

2-POSITION VALVES

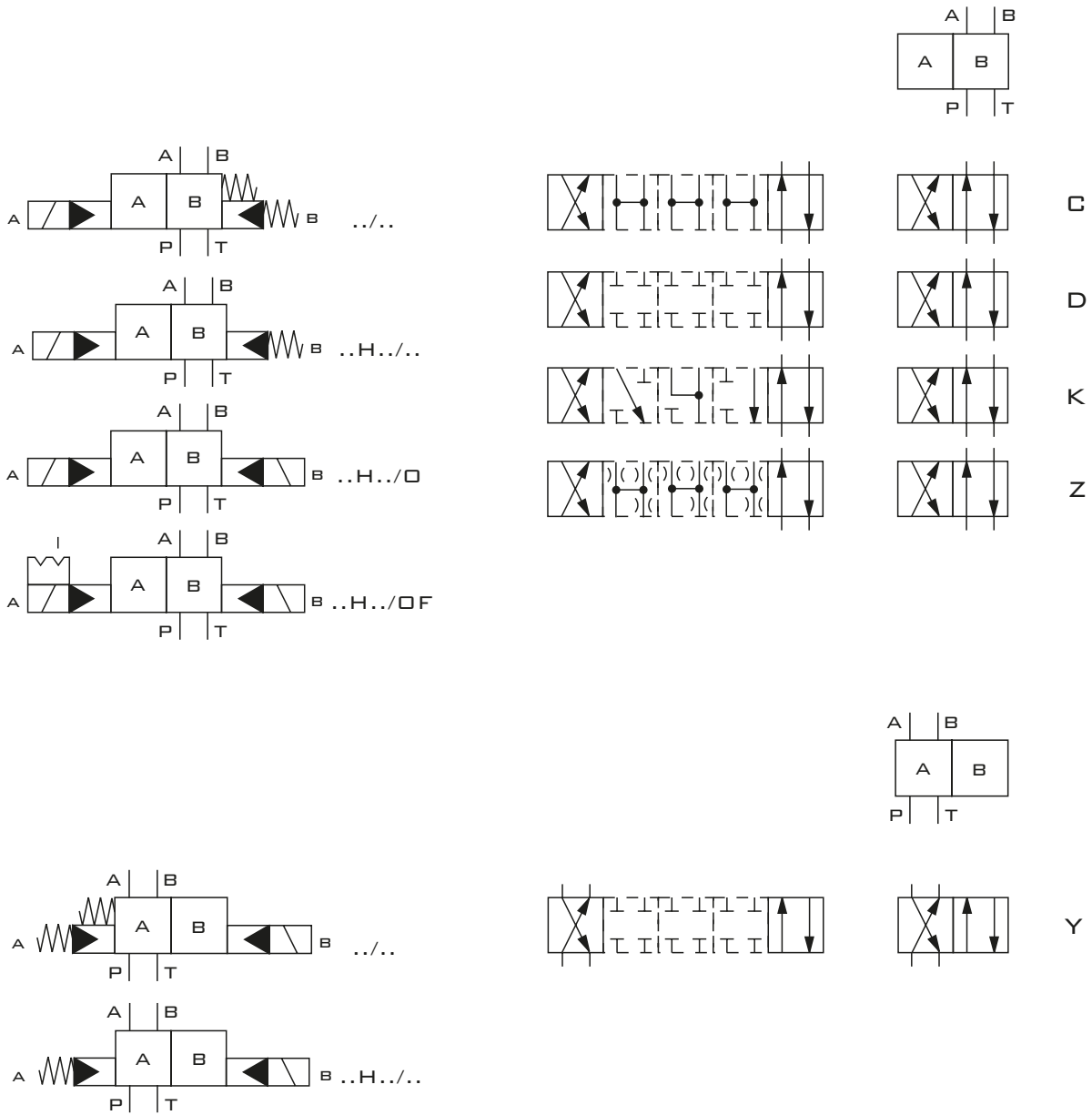

SEE ALSO:
WE6, WE10

SOLENOID PILOT OPERATED
DIRECTIONAL CONTROL VALVES

SPOOL SYMBOLS

3-POSITION VALVES

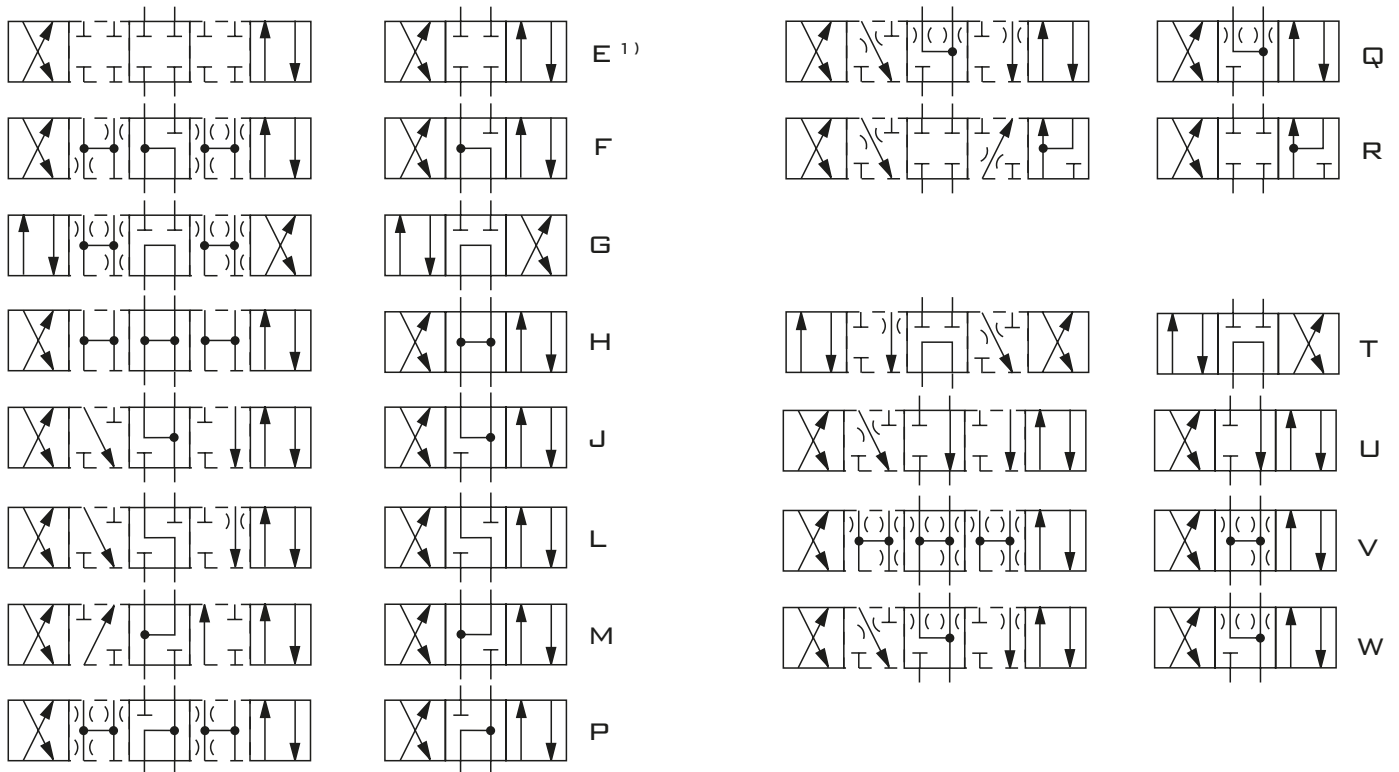
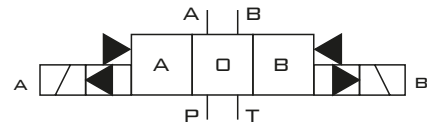
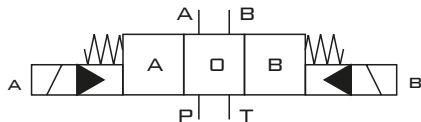

1) EXAMPLE: SYMBOL E WITH ACTUATING SIDE "A" = ORDERING CODE ..EA..

SUBPLATE INSTALLATION DIMENSIONS 4WEH16...

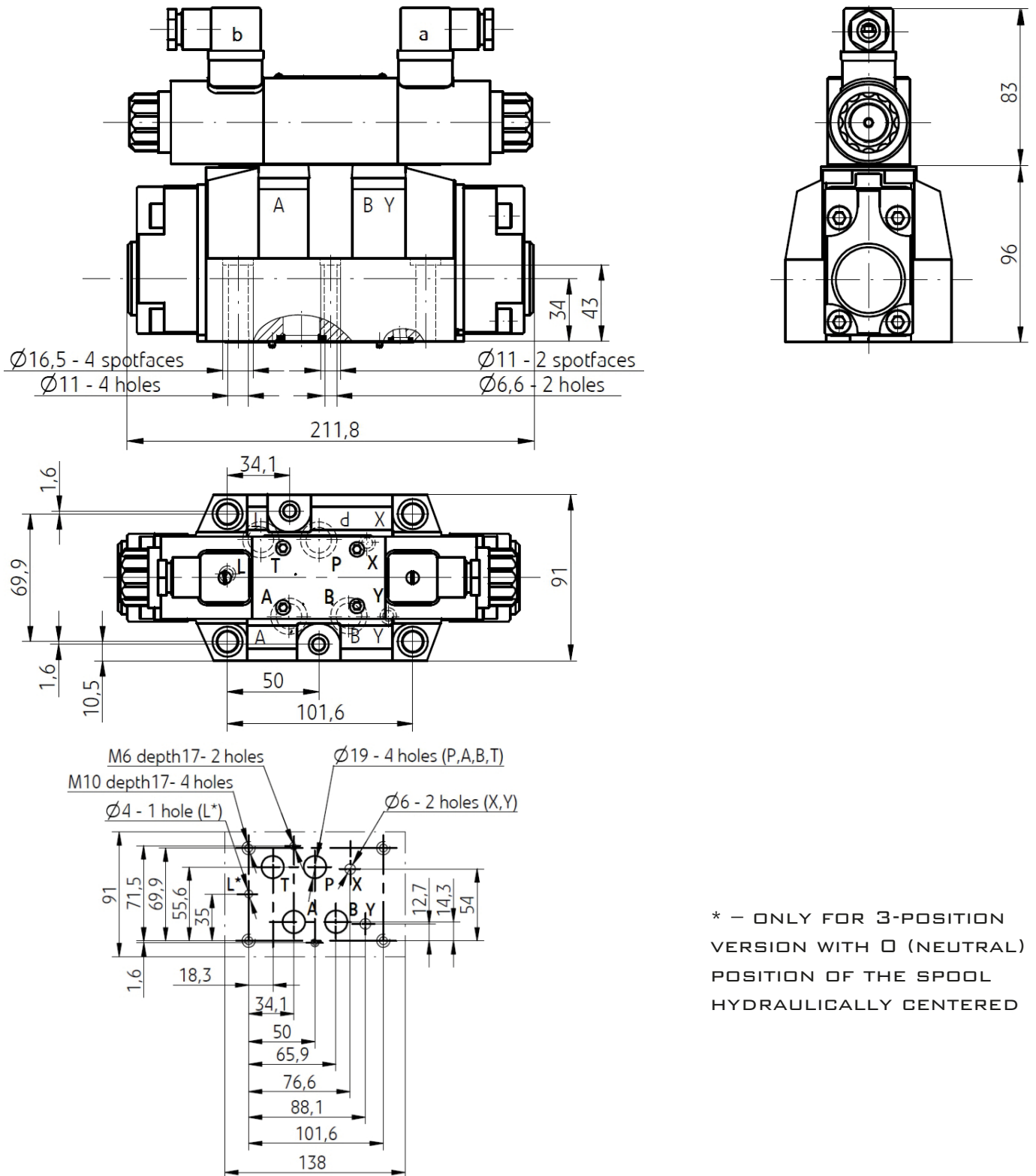

* - ONLY FOR 3-POSITION
VERSION WITH O (NEUTRAL)
POSITION OF THE SPOOL
HYDRAULICALLY CENTERED

SUBPLATE INSTALLATION DIMENSIONS 4WEH25...

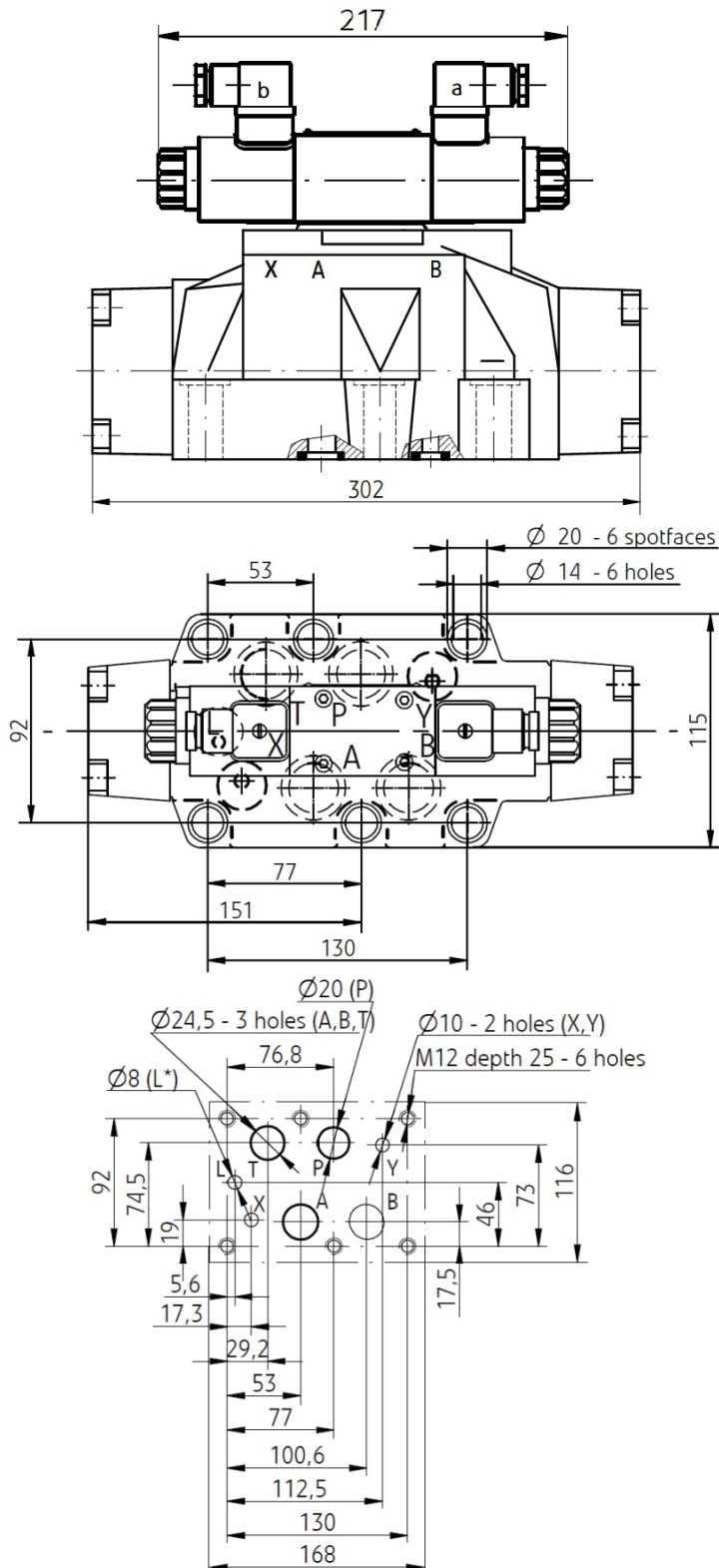

* - ONLY FOR 3-POSITION
VERSION WITH O (NEUTRAL)
POSITION OF THE SPOOL
HYDRAULICALLY CENTERED

SUBPLATE INSTALLATION DIMENSIONS 4WEH32...

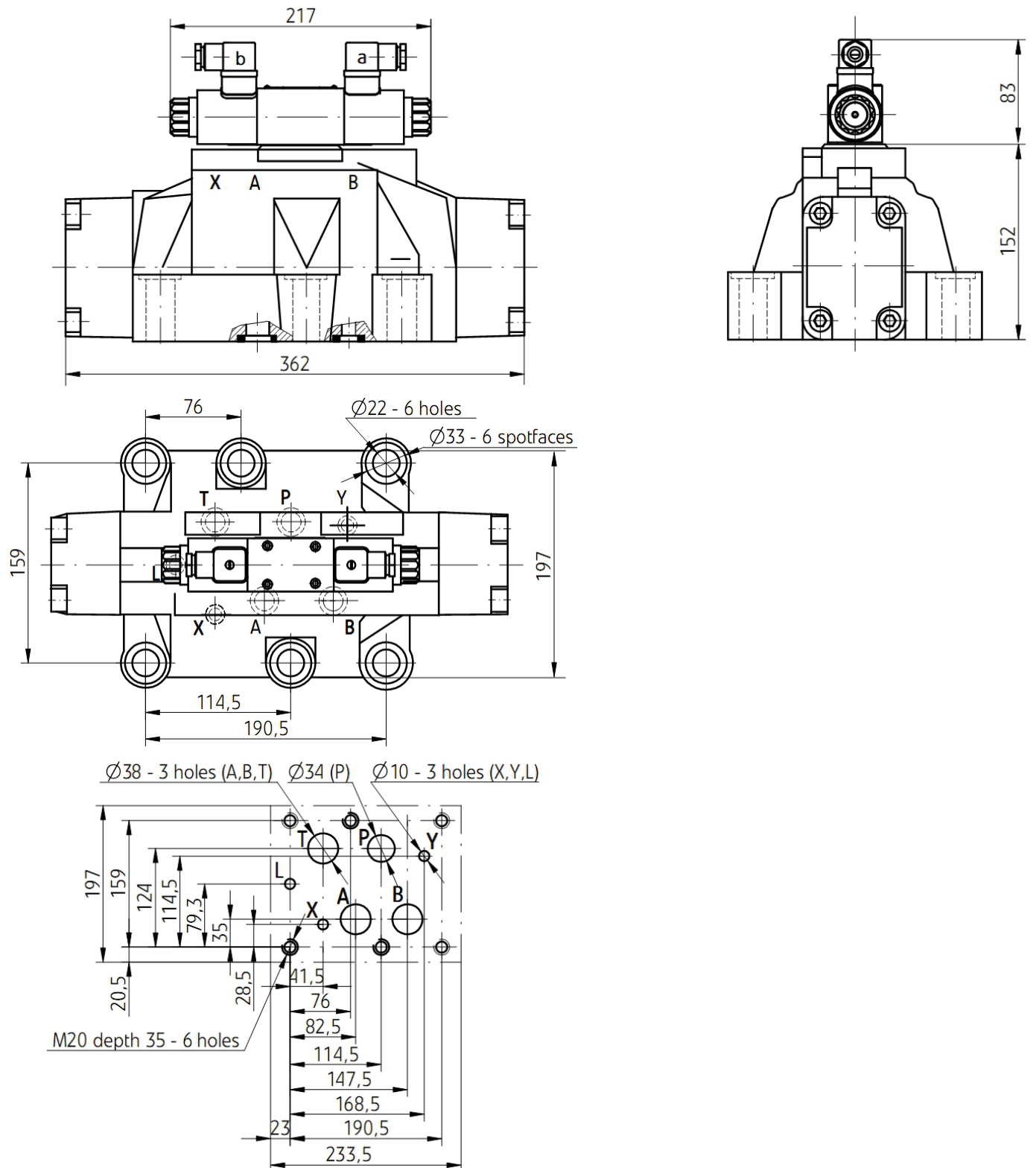

ACCESSORIES FOR STANDART VERSION
OF THE DIRECTIONAL VALVE WEH 16

PRE-LOAD VALVE

VERSIONS: ...4WEH16.../...P4,5...

...4WEH16.../...P7...

DIRECTIONAL VALVE TYPE...4WEH16... WITH INTERNAL PILOT OIL SUPPLY (X) - VERSIONS: ...E...; ...ET... WITH SPOOLS C, Z, F, G, H, S, T, V (DIAGRAMS ACCORDING TO PAGE 8) WITH PRESSURELESS CIRCULATION OF HYDRAULIC FLUID (SUPPLY AND DRAIN CONNECTED AT WORKING OR INDIRECT POSITIONS) MUST BE EQUIPPED WITH THE PRE-LOAD VALVE (2) FIXED IN PORT P OF THE MAIN VALVE (1).

CRACKING PRESSURE FOR PRE-LOAD VALVES:

VERSION P 4.5 - 0,45 MPA

VERSION P 7 - 0,7 MPA

FOR DIRECTIONAL VALVES WITH FIXED PRESSURE RATIO VALVE VERSIONS H4 - 4WEH16.../...D1... THE PRE-LOAD VALVE P7 MUST BE APPLIED.

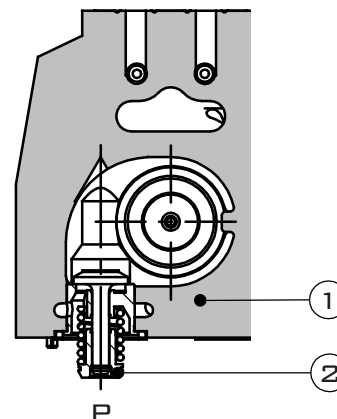

1 - MAIN VALVE BODY
2 - PRE-LOAD VALVE

PERFORM PERFORMANCE CURVES FOR PRE- OR PRE- OR PRE-LOAD VALVES (MEASURED AT VISCOSITY $\nu = 41 \text{ mm}^2/\text{s}$ AND TEMPERATURE $T = 50^\circ\text{C}$)

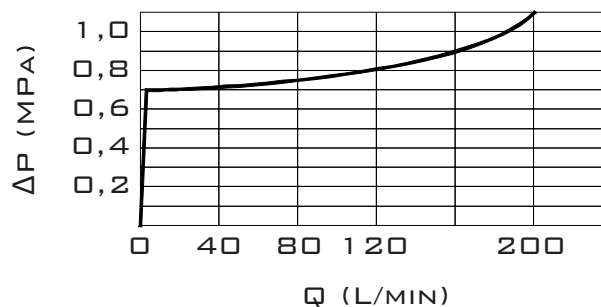
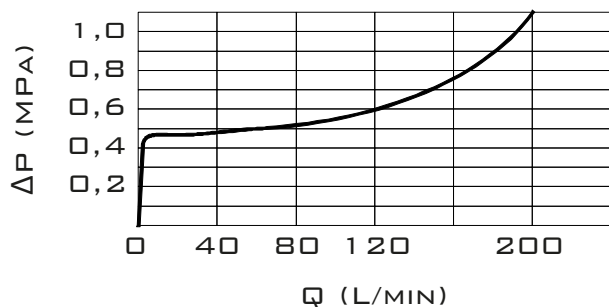

THROTTLE INSERT

VERSION ...4WEH16.../...B...

DIRECTIONAL VALVES TYPE ...4WEH16... MAY BE EQUIPPED WITH THROTTLE INSERT (3) IN PORT P IN PILOT VALVE (2) WHICH ALLOWS TO DELAY SWITCHING TIME OF THE MAIN VALVE.

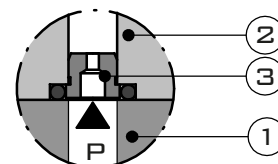

1 - MAIN VALVE
2 - PILOT VALVE
3 - THROTTLE INSERT

**ACCESSORIES FOR STANDART VERSION
OF THE DIRECTIONAL VALVE WEH25 AND WEH32**
PRE-LOAD VALVE

VERSIONS: ...4WEH25.../...P4,5...

...4WEH25.../...P7...

DIRECTIONAL VALVE TYPE...WEH25... WITH INTERNAL
PILOT OIL SUPPLY (X) - VERSIONS:

... 4WEH25.../...E...

...4WEH25.../...ET...

WITH SPOOLS WITH PRESSURELESS CIRCULATION OF
HYDRAULIC FLUID MUST BE EQUIPPED WITH THE
PRE-LOAD VALVE (2) FIXED IN PORT P OF THE MAIN
VALVE (1).

CRACKING PRESSURE FOR PRE-LOAD VALVES:

VALVE VERSION P 4.5 - 0,45 MPA

VALVE VERSION P 7 - 0,7 MPA

FOR DIRECTIONAL VALVES WITH FIXED PRESSURE
RATIO VALVE - VERSIONS ...4WEH25.../...D1... THE
PRE-LOAD VALVE P7 MUST BE APPLIED.

PERFORM PERFORMANCE CURVES FOR PRE- OR PRE- OR PRE-LOAD VALVES
(MEASURED AT VISCOSITY $\nu = 41 \text{ MM}^2/\text{S}$ AND TEMPERATURE $T = 50^\circ\text{C}$)

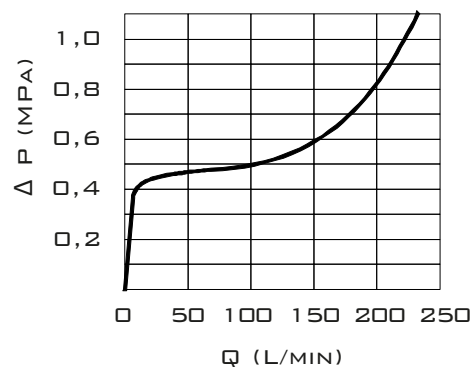
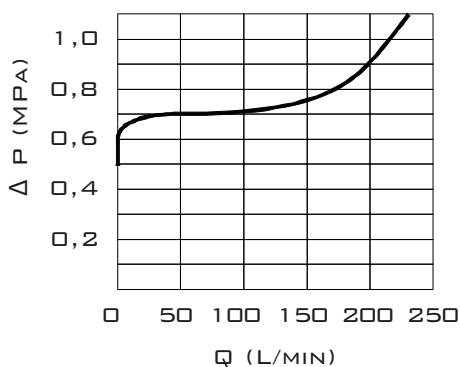

THROTTLE INSERT

VERSION ...4WEH25.../...B...

DIRECTIONAL VALVES TYPE...WEH22... MAY BE
EQUIPPED WITH THROTTLE INSERT (3) IN PORT P IN
PILOT VALVE (2) WHICH ALLOWS TO DELAY SWITCHING
TIME OF THE MAIN VALVE.

...4WEH22.../...B...

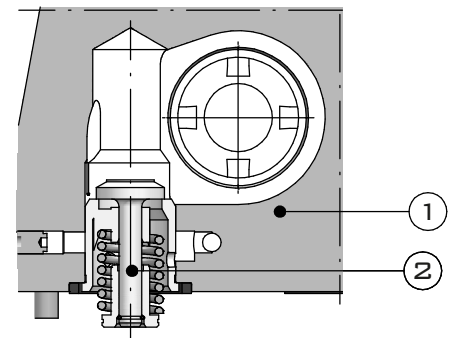
...4WEH25.../...P...



1 - MAIN VALVE BODY
2 - PRE-LOAD VALVE

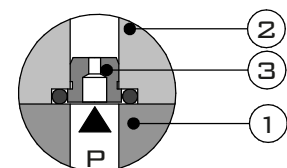

1 - MAIN VALVE
2 - PILOT VALVE
3 - THROTTLE INSERT

PILOT FLUID SUPPLY

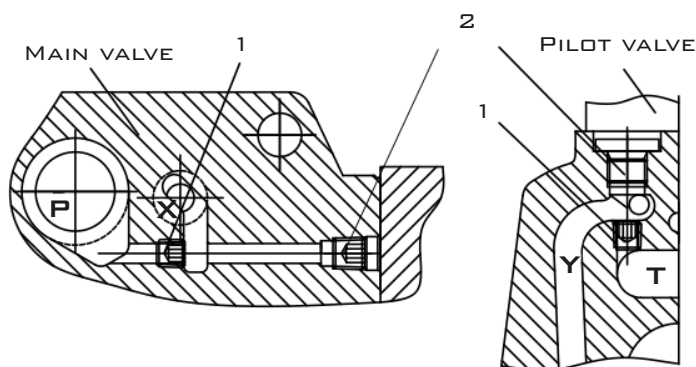

4WEH16

1. CONVERSION BETWEEN INTERNAL SUPPLY AND EXTERNAL SUPPLY:
DISMOUNTING PLUG SCREW (2) FROM P CHANNEL ON THE SIDESURFACE OF MAIN VALVES AND INSTALLING M6 BOLT (1) IS INTERNAL SUPPLY. DISMOUNTING M6 PLUG BOLT (1) IS INTERNAL SUPPLY.
2. CONVERSION BETWEEN INTERNAL DRAIN AND EXTERNAL DRAIN:
DISMOUNTING PLUG SCREW (2) FROM T HOLE ON THE TOP OF MAIN VALVES AND INSTALLING M6 PLUG BOLT (1) IS INTERNAL DRAIN. DISMOUNTING M6 BOLT (1) IS EXTERNAL DRAIN.

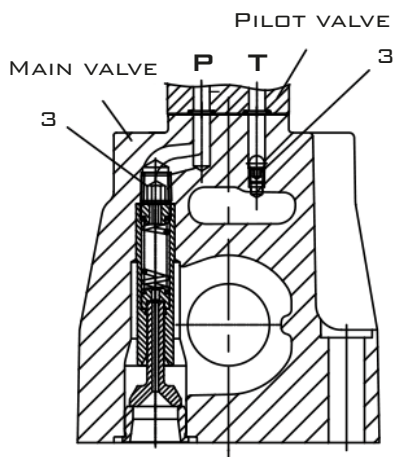

4WEH25

1. CONVERSION BETWEEN INTERNAL SUPPLY AND EXTERNAL SUPPLY:
P CHANNEL ON THE TOP OF MAIN VALVE BODIES WITH M6 BOLT (3) IS EXTERNAL SUPPLY AND WITH M6 BOLT (3) DISMOUNTED IS INTERNAL SUPPLY.
2. CONVERSION BETWEEN INTERNAL DRAIN AND EXTERNAL DRAIN:
DISMOUNTING PLUG BOLT (3) FROM T HOLE ON THE TOP OF MAIN VALVES AND INSTALLING M6 PLUG BOLT (1) IS INTERNAL DRAIN. DISMOUNTING M6 BOLT (1) IS EXTERNAL DRAIN.

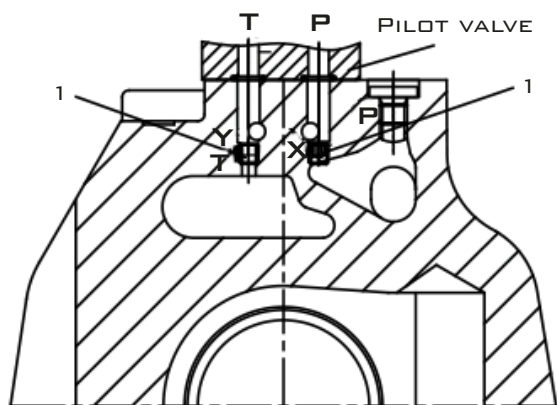

4WEH32

1. CONVERSION BETWEEN INTERNAL SUPPLY AND EXTERNAL SUPPLY:
DISMOUNTING PLUG SCREW (1) FROM P HOLE ON THE UNDERSURFACE OF MAIN VALVES AND INSTALLING M6 BOLT (1) IS INTERNAL SUPPLY. DISMOUNTING M6 PLUG BOLT (1) IS INTERNAL SUPPLY.
2. CONVERSION BETWEEN INTERNAL DRAIN AND EXTERNAL DRAIN:
DISMOUNTING PLUG SCREW (1) FROM T HOLE ON THE TOP OF MAIN VALVES AND INSTALLING M6 PLUG BOLT (1) IS INTERNAL DRAIN. DISMOUNTING M6 BOLT (1) IS EXTERNAL DRAIN.

