



VALVOLE DI RITEGNO

Z2S16

PILOT OPERATED CHECK VALVES

Z2S16 SERIES ARE PILOT OPERATED CHECK VALVES.
 THIS VALVES ARE USED TO SHUT-OFF AN OIL FLOW IN ONE DIRECTION AND ALLOW FREE FLOW IN THE OPPOSITE DIRECTION.
 THEY CAN ALSO BE OPENED IN THE DIRECTION OF CLOSURE.



TECHNICAL DATA

SIZE	16
OPERATING PRESSURE (MPA)	31.5
MAX. FLOW RATE (L/MIN)	200
FLUID TEMPERATURE (°C)	-30 - 80
WEIGHT (KG)	6.8
VALVE BODY (MATERIAL)	CASTING PHOSPHATING SURFACE

SCHEMES

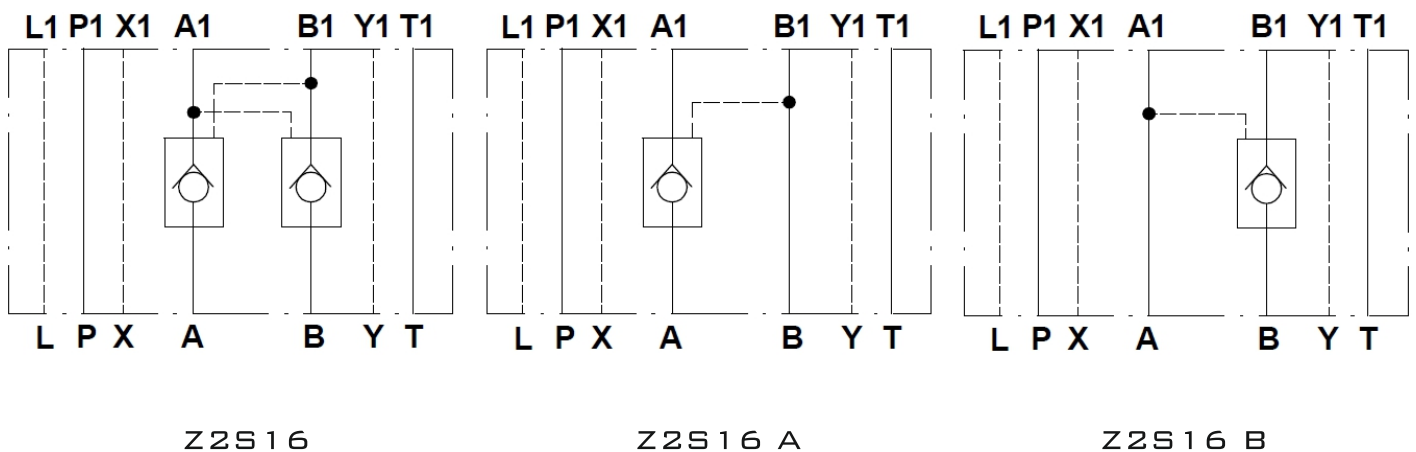

CHARACTERISTIC CURVES

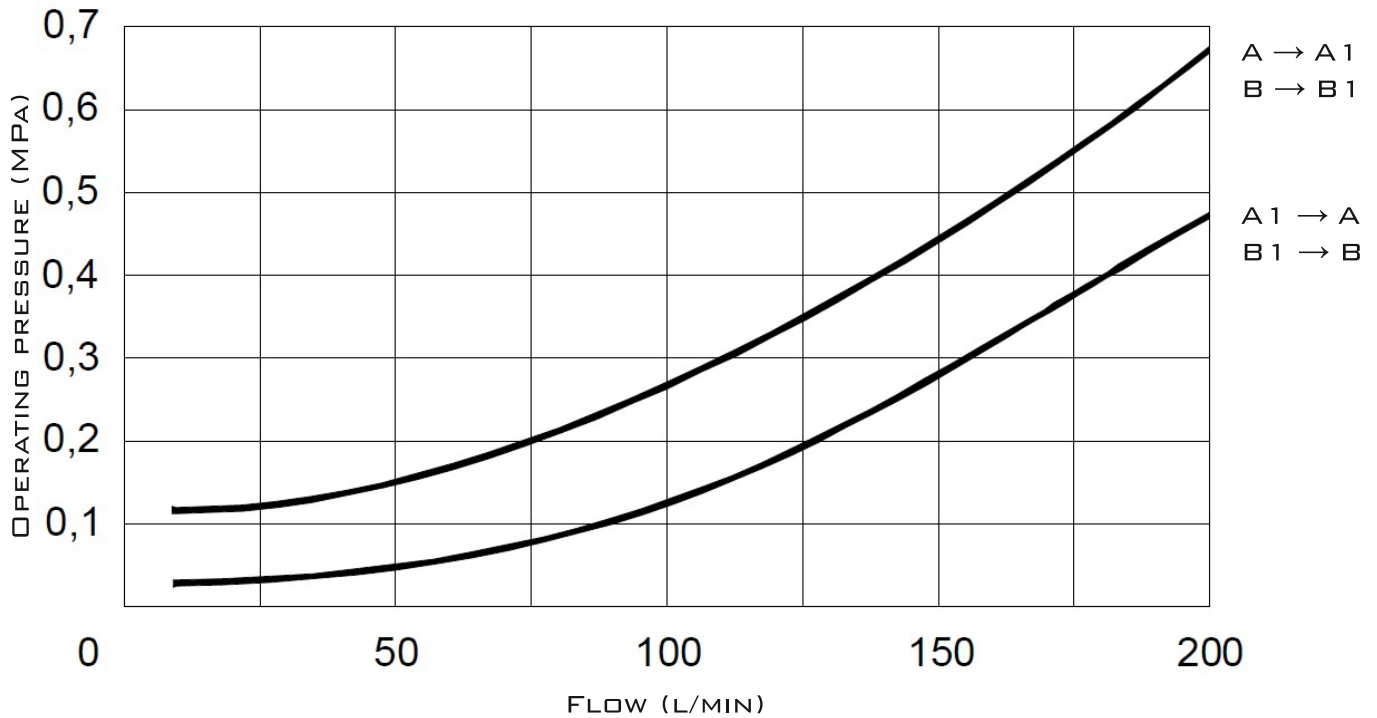

SUBPLATE INSTALLATION DIMENSIONS

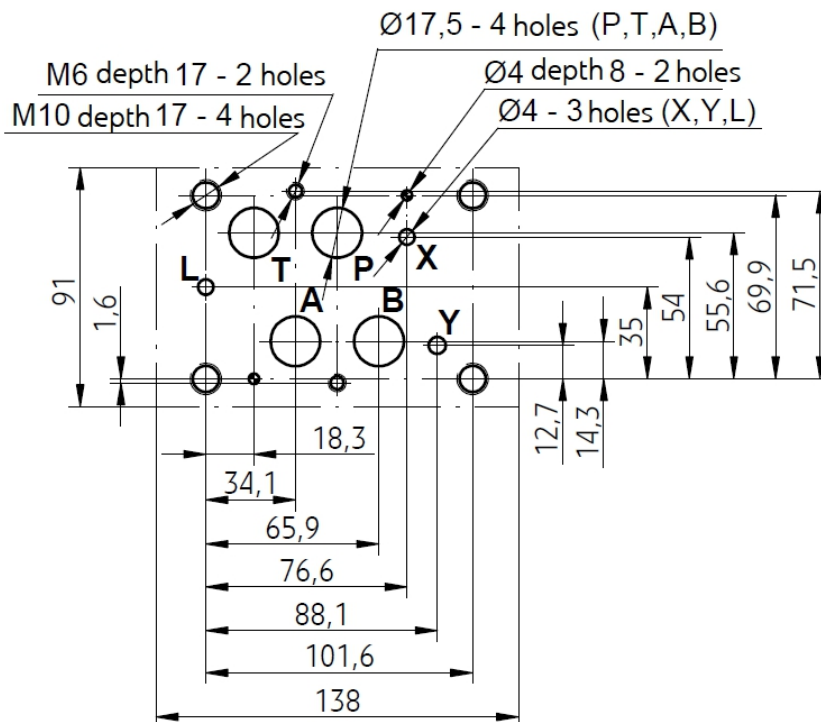

SUBPLATE INSTALLATION DIMENSIONS

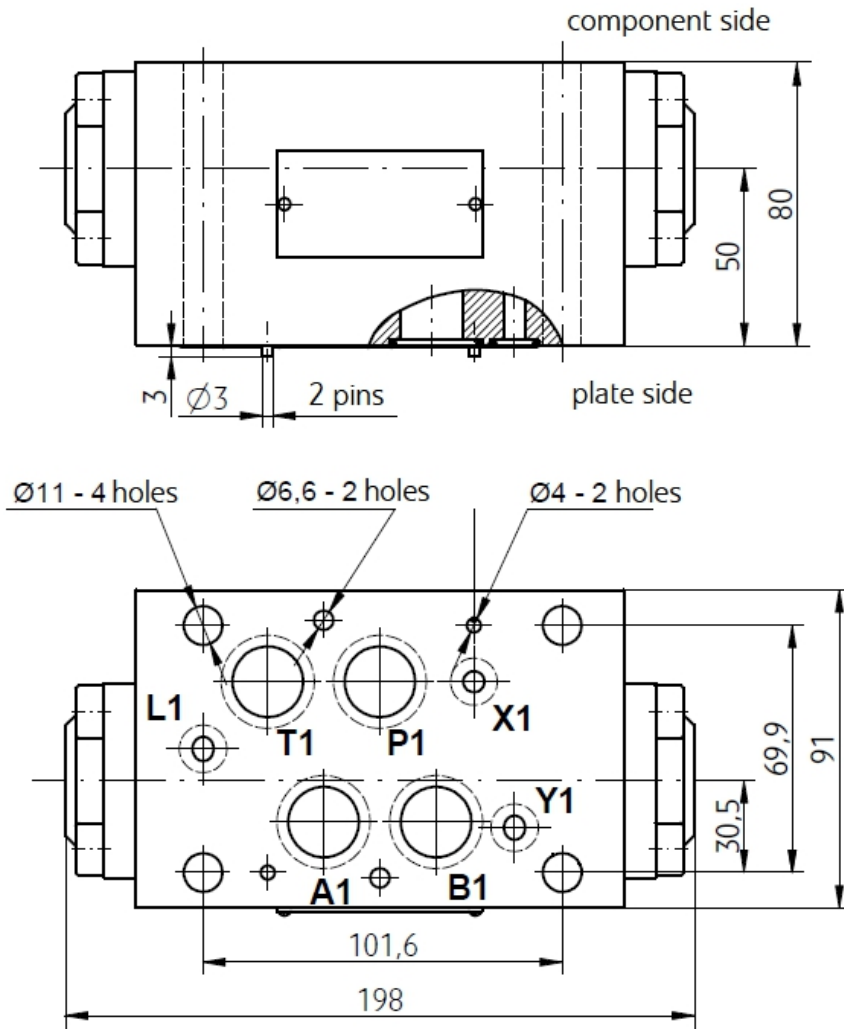

ORDER CODE

Z2S	16			30	
-----	----	--	--	----	--

16 = 16 SIZE

NO CODE = PORT A, B WITH CHECK VALVE
 A = PORT A WITH CHECK VALVE
 B = PORT B WITH CHECK VALVE

1 = OPENING PRESSURE 0.15 MPA
 2 = OPENING PRESSURE 0.3 MPA
 3 = OPENING PRESSURE 0.6 MPA

NO CODE = MINERAL
 SUBSTANCE HYDRAULIC OIL
 V = PHOSPHATE EATER
 HYDRAULIC OIL

30 = 30 SERIES