



VALVOLE DI PRESSIONE

ZDR

DIRECT MODULAR  
REDUCING VALVES

ZDR SERIES ARE 3-WAY DIRECT OPERATED PRESSURE REDUCING VALVES, WHICH ARE USED TO REDUCE THE PRESSURE IN A CERTAIN CIRCUIT LOWER THAN OF THE MAIN CIRCUIT.



### TECHNICAL DATA

SIZE	6	10
OPERATING PRESSURE (MPA)	31.5	31.5
MAX. FLOW RATE (L/MIN)	30	50
FLUID TEMPERATURE (°C)	-20 - 80	-20 - 80
WEIGHT (KG)	1.3	2.8
VALVE BODY (MATERIAL)	CASTING PHOSPHATING SURFACE	

### SCHEMES

1=COMPONENT SIDE, 2=PLATE SIDE

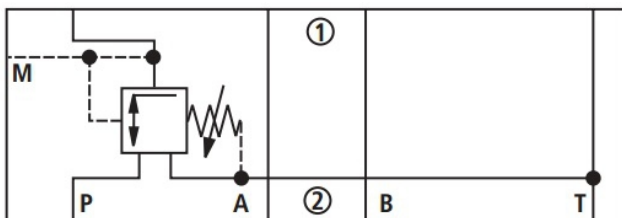

ZDR 6 DP ... YM

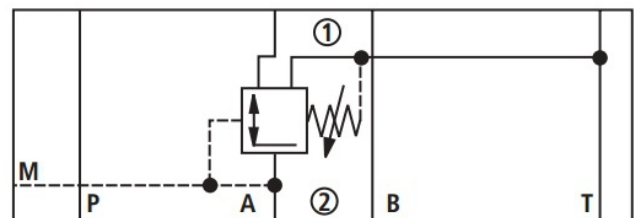

ZDR 6 DA ... YM

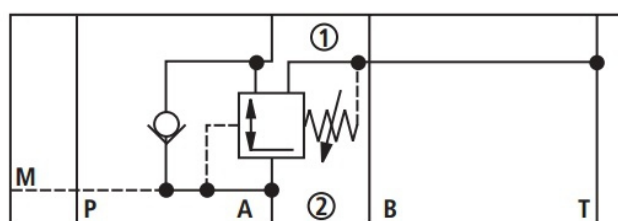

ZDR 6 DA ... Y



DIRECT MODULAR  
REDUCING VALVES

**CHARACTERISTIC CURVES**

**ZDR6**

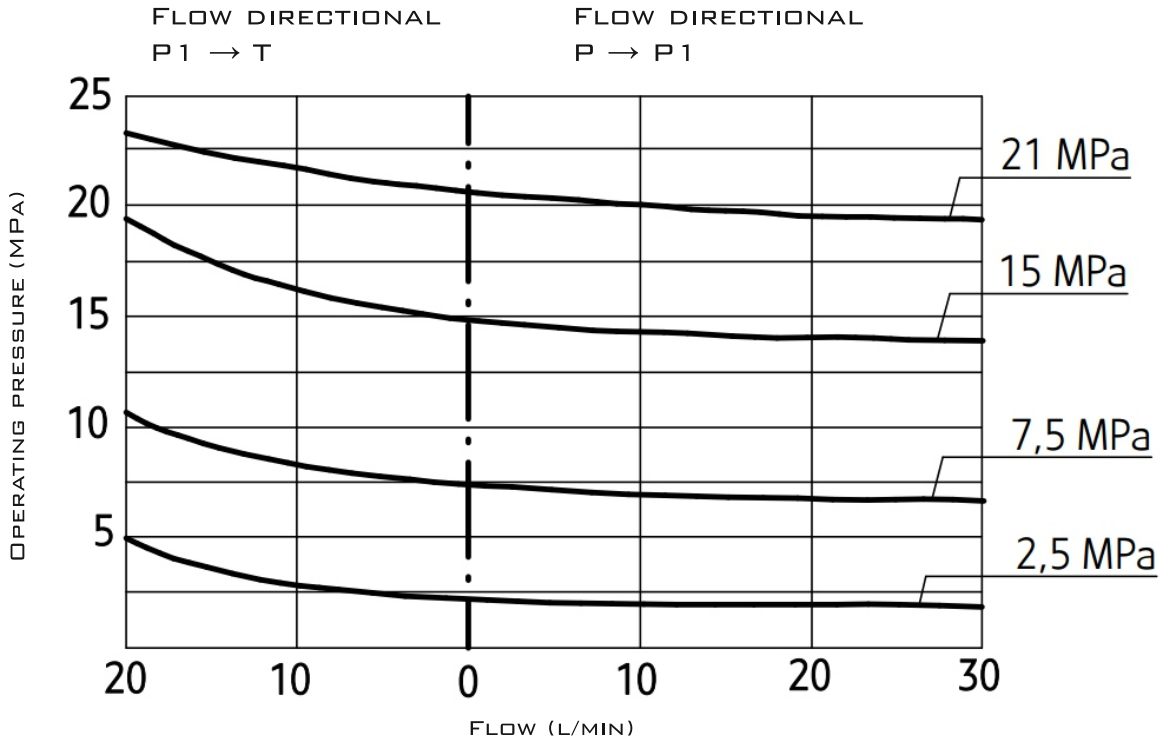

**ZDR10**

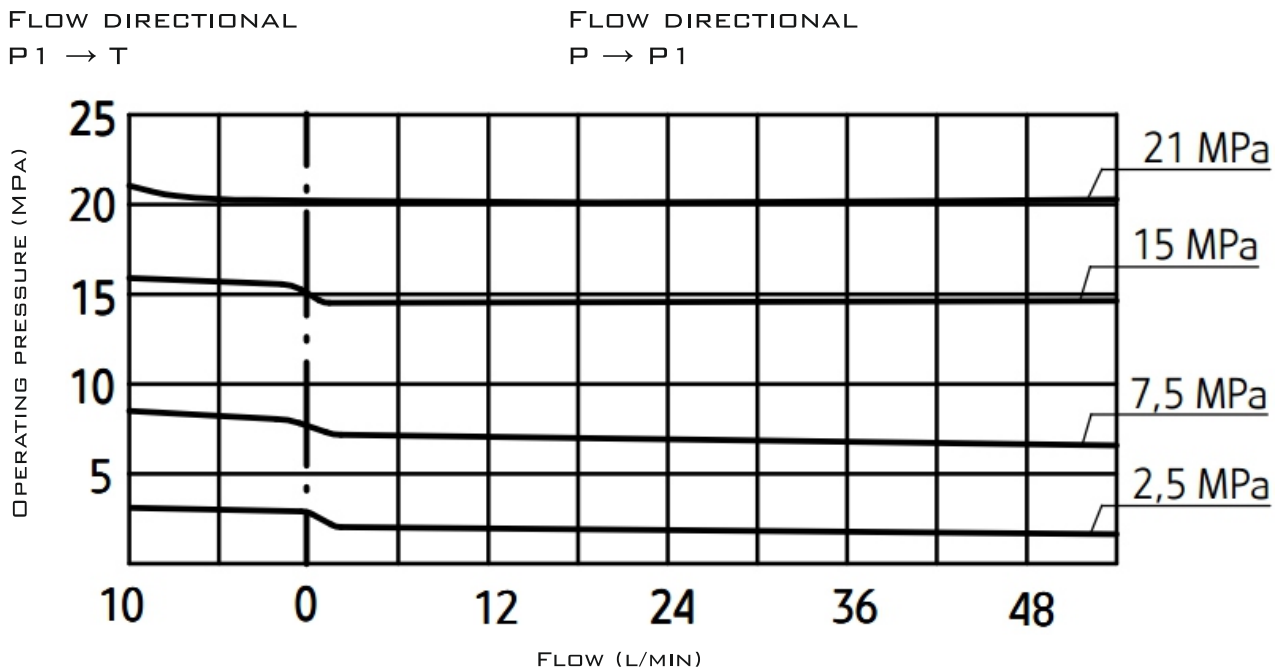

MODULAR INSTALLATION DIMENSIONS

ZDR6

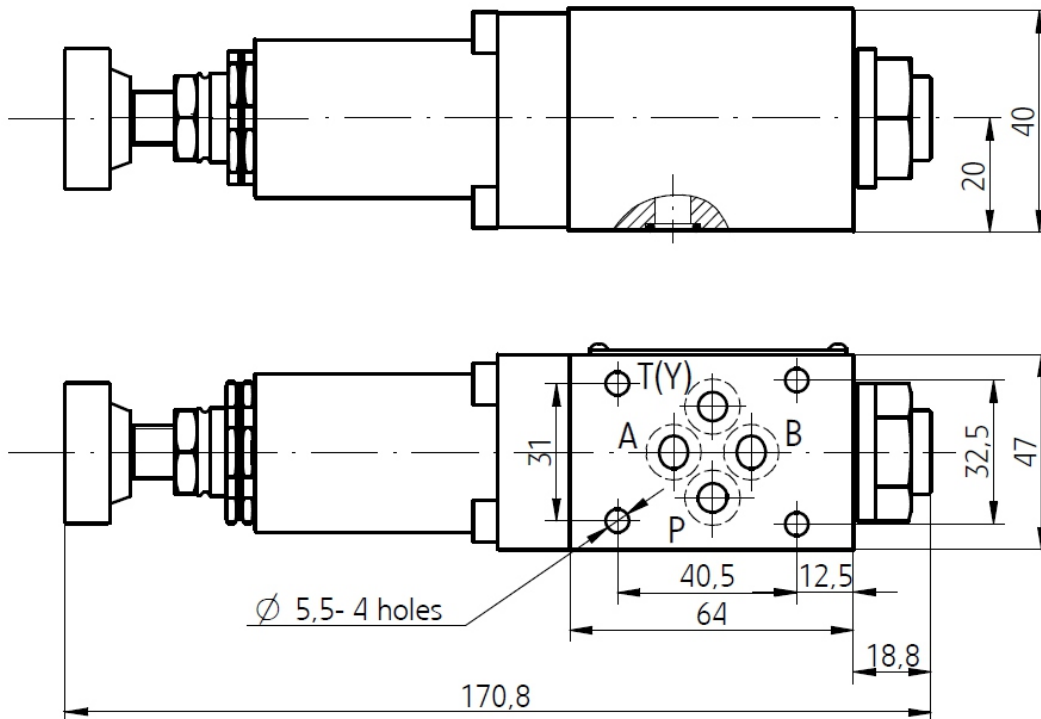

ZDR10

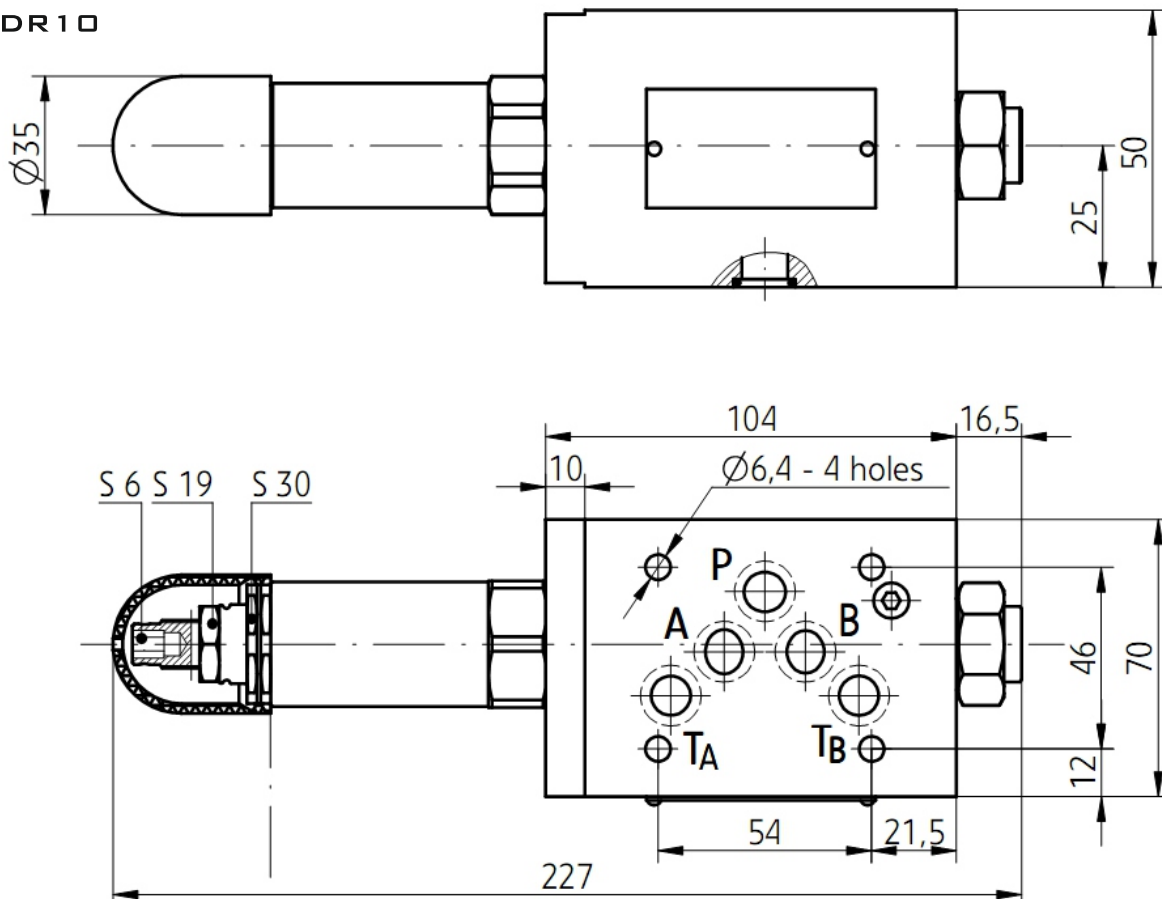

DIRECT MODULAR  
REDUCING VALVES

### MODULAR INSTALLATION DIMENSION SIZE - 6

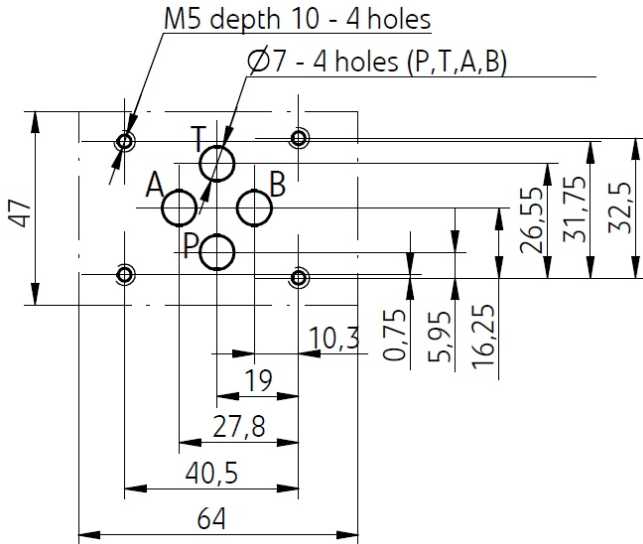

### MODULAR INSTALLATION DIMENSION SIZE - 10

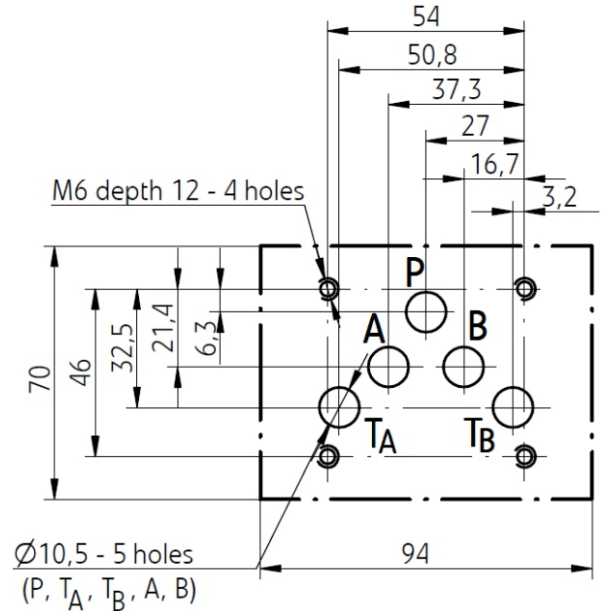

### ORDER CODE

Z	DR	D											
---	----	---	--	--	--	--	--	--	--	--	--	--	--

Z=MODULAR  
MOUNTING

6=6 SIZE  
10=10 SIZE

D=DIRECT OPERATED

A=PRESSURE REDUCTION IN  
PORT A

P=PRESSURE REDUCTION IN  
PORT P

30=30 SERIES (6 SIZE)  
40=40 SERIES (10 SIZE)

1=HANDLE  
2=ADJUSTING BOLT WITH PROTECT  
COVER  
3=KNOB WITH HANDLE

NO CODE=NBR SEALS  
V=FKM SEALS

NO CODE=CHECK VALVE  
M=WITHOUT CHECK VALVE

Y=PILOT OIL INTERNAL SUPPLY  
EXTERNAL DRAIN

25=MAX SECONDARY PRESSURE 2.5 MPA  
75=MAX SECONDARY PRESSURE 7.5 MPA  
150=MAX SECONDARY PRESSURE 15 MPA  
210=MAX SECONDARY PRESSURE 21 MPA