



PE3029

PE-0-1BRDR14-MFPKG/US/ /E



Pressure sensors

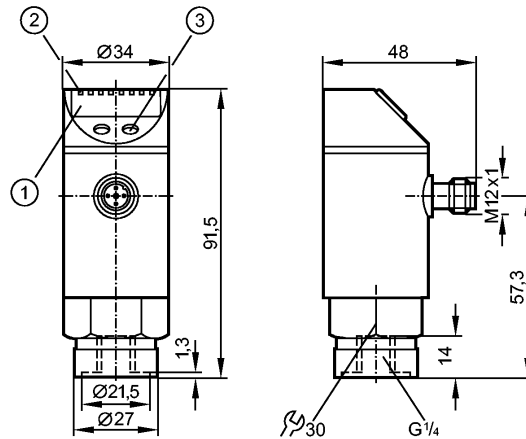

- 1: 4-digit alphanumeric display
- 2: LEDs (display unit / switching status)
- 3: Programming button



Product characteristics

- Combined pressure sensor
- Quick disconnect
- Sealing of the measuring cell: EPDM
- Function programmable
- Process connection: G 1/4 I
- Switching output, Analog output
- 4-digit alphanumeric display
- Measuring range: -1000...0 mbar

Application

Application	Type of pressure: relative pressure Liquids and gases Cannot be used for oils
Pressure rating [mbar]	10000
Bursting pressure min. [mbar]	30000
Medium temperature [°C]	-25...80

Electrical data

Electrical design	DC PNP
Operating voltage [V]	18...36 DC ¹⁾
Current consumption [mA]	< 50
Insulation resistance [MΩ]	> 100 (500 V DC)
Protection class	III
Reverse polarity protection	yes
Overvoltage protection [V]	up to 40 V

Outputs

Output	Switching output, Analog output
Output function	normally open / closed programmable; 4...20 mA or 0...10 V
Current rating [mA]	250
Voltage drop [V]	< 2
Short-circuit protection	yes (non-latching)



PE3029

PE-0-1BRDR14-MFPKG/US/ /E



Pressure sensors

Switching frequency [Hz]	≤ 170
Analog output	4...20 mA / 0...10 V
Max. load [Ω]	4...20 mA: max. 500 / 0...10 V: min. 2000

Measuring / setting range	
Display unit	mbar, kPa, psi, inHg
Measuring range [mbar]	-1000...0
Setting range	
Set point, SP [mbar]	-990...0
Reset point, rP [mbar]	-995...-5
in steps of [mbar]	5
Factory setting	SP1 = -750 mbar; rP1 = -770 mbar

Accuracy / deviations	
Accuracy / deviations (in % of the span)	
Switch point accuracy	< ± 0.5
Characteristics deviation *)	< ± 0.25 (BFSL) / < ± 0.5 (LS)
Hysteresis	< ± 0.25
Repeatability **)	< ± 0.1
Long-term stability ***)	< ± 0.05
Temperature coefficients (TEMPCO) in the temperature range -20...80° C (in % of the span per 10 K)	
Greatest TEMPCO of the zero point	0.2
Greatest TEMPCO of the span	0.2

Reaction times	
Power-on delay time [s]	0.3
Delay time programmable dS, dr [s]	0; 0.2...50
Response time analog output [ms]	< 3
Integrated watchdog	yes

Software / programming	
Programming options	hysteresis / window function; N.O. / N.C; on delay, off delay; damping; display unit; current / voltage output
Adjustment of the switch point	Programming button

Environment	
Ambient temperature [°C]	-20...80
Storage temperature [°C]	-40...100
Protection	IP 67

Tests / approvals	
EMC	EN 61000-4-2 ESD: 4 kV CD / 8 kV AD EN 61000-4-3 HF radiated: 10 V/m EN 61000-4-4 Burst: 2 kV EN 61000-4-5 Surge: 0.5/1 kV EN 61000-4-6 HF conducted: 10 V
Shock resistance	DIN IEC 68-2-27: 50 g (11 ms)
Vibration resistance	DIN IEC 68-2-6: 20 g (10...2000 Hz)
MTTF [Years]	213

Mechanical data	
Process connection	G ¼ I
Materials (wetted parts)	stainless steel 316L / 1.4404; ceramics (99.9 % Al ₂ O ₃); EPDM



PE3029

PE-0-1BRDR14-MFPKG/US/ /E

Pressure sensors

Housing materials	stainless steel (304S15); stainless steel 316L / 1.4404; PC (Makrolon); PBT (Pocan); PEI; FPM (Viton); EPDM/X (Santoprene); PTFE
Switching cycles min.	100 million
Weight [kg]	0.265

Displays / operating elements	
Display	Display unit 4 x LED green Switching status LED yellow Function display 4-digit alphanumeric display Measured values 4-digit alphanumeric display

Electrical connection	
Connection	M12 connector; gold-plated contacts

Wiring

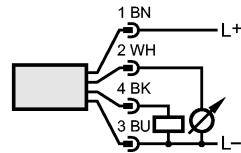

Remarks	
Remarks	1) to EN50178, SELV, PELV *) BFSL = Best Fit Straight Line / LS = Limit Value Setting **) with temperature fluctuations < 10 K ***) in % of value of measuring range / 6 months

Pack quantity [piece]	1
-----------------------	---