



PN2569

PN-+,5BRER14-MFRKG/US/ IV



Pressure sensors

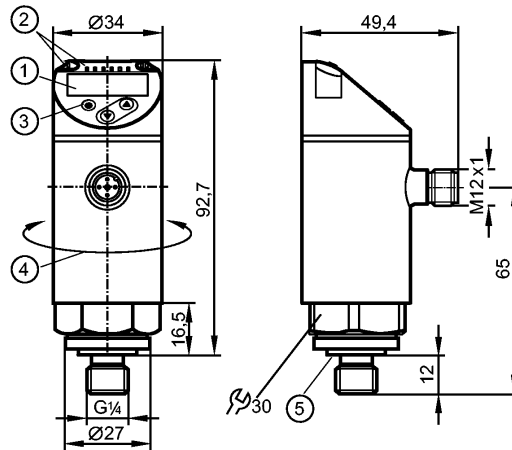

- 1: 4-digit alphanumeric display / alternating indication of red and green
- 2: LEDs (display unit / switching status)
- 3: Programming button
- 4: Upper part of the housing can be rotated by 345°
- 5: Process connection sealing FKM / DIN 3869



Product characteristics

Electronic pressure sensor

M12 connector

Function programmable

Measuring element: ceramic-capacitive pressure measuring cell

Process connection: G 1/4 A / M5 I (according to DIN EN ISO 1179-2)

2 outputs

OUT1 = switching output

OUT2 = switching output or analog output

4-digit alphanumeric display / alternating indication of red and green

Measuring range: -500...500 mbar / -7.26...7.26 psi / -50...50 kPa

Application

Application	Type of pressure: relative pressure Group 2 fluids according to the Pressure Equipment Directive (PED), group 1 fluids on request		
Pressure rating	10000 mbar	145 psi	1000 kPa
Bursting pressure min.	30000 mbar	450 psi	3000 kPa
Vacuum resistance [mbar]	-1000		
Medium temperature [°C]	-25...80		

Electrical data

Electrical design	DC PNP/NPN
Operating voltage [V]	18...30 DC ¹⁾
Current consumption [mA]	< 35
Insulation resistance [MΩ]	> 100 (500 V DC)
Protection class	III
Reverse polarity protection	yes

Outputs

Output	2 outputs OUT1 = switching output OUT2 = switching output or analog output
--------	--



PN2569

PN-+,5BRER14-MFRKG/US/ IV



Pressure sensors

Output function	2 x normally open / closed programmable or 1 x normally open / closed programmable + 1 x analog (4...20 mA / 0...10 V; programmable 1:5)		
Current rating [mA]	250		
Voltage drop [V]	< 2		
Short-circuit protection	yes (non-latching)		
Overload protection	yes		
Switching frequency [Hz]	≤ 500		
Analog output	4...20 mA; 0...10 V		
Max. load [Ω]	4...20 mA: max. 500		
Min. load resistance [Ω]	0...10 V: min. 2000		

Measuring / setting range

Measuring range	-500...500 mbar	-7.26...7.26 psi	-50...50 kPa
Setting range			
Set point, SP	-494...500 mbar	-7.16...7.26 psi	-49.4...50 kPa
Reset point, rP	-498...496 mbar	-7.22...7.2 psi	-49.8...49.6 kPa
Analog start point, ASP	-500...300 mbar	-7.26...4.36 psi	-50...30 kPa
Analog end point, AEP	-300...500 mbar	-4.36...7.26 psi	-30...50 kPa
in steps of	2 mbar	0.02 psi	0.2 kPa

Accuracy / deviations

Accuracy / deviations (in % of the span) Turn down 1:1			
Switch point accuracy	< ± 0.4		
Characteristics deviation *)	< ± 0.25 (BFSL) / < ± 0.5 (LS)		
Hysteresis	< ± 0.1		
Repeatability **)	< ± 0.1		
Long-term stability ***)	< ± 0.05		
Temperature coefficients (TEMPCO) in the temperature range -25...80° C (in % of the span per 10 K)			
Greatest TEMPCO of the zero point	0.2		
Greatest TEMPCO of the span	0.2		

Reaction times

Power-on delay time [s]	0.3		
Min. response time switching output [ms]	< 1.5		
Delay time programmable dS, dr [s]	0...50		
Damping for the switching output (dAP) [s]	0...4		
Damping for the analog output (dAA) [s]	0...4		
Response time analog output [ms]	< 3		
Integrated watchdog	yes		

Software / programming

Programming options	hysteresis / window function; NO / NC; on delay, off delay; damping; display unit; current/ voltage output		
---------------------	--	--	--

Interfaces

IO-Link Device			
Transfer type	COM2		
IO-Link revision	1.1		



PN2569

PN-+,5BRER14-MFRKG/US/ IV



Pressure sensors

SDCI standard	IEC 61131-9
IO-Link Device ID	468 d / 00 01 d4 h
Profiles	Smart Sensor: Process Data Variable; Device Identification, Device Diagnosis
SIO mode	yes
Required master port class	A
Process data analogue	1
Process data binary	2
Min. process cycle time [ms]	2.3

Environment	
Ambient temperature [°C]	-25...80
Storage temperature [°C]	-40...100
Protection	IP 65 / IP 67

Tests / approvals	
Pressure equipment directive	97/23/EG: sound engineering practice
EMC	DIN EN 61000-6-2 DIN EN 61000-6-3
Shock resistance	DIN EN 60068-2-27 50 g (11 ms)
Vibration resistance	DIN EN 60068-2-6 20 g (10...2000 Hz)
MTTF [Years]	138
UL approval number	J012

Mechanical data	
Process connection	G ¼ A / M5 I (according to DIN EN ISO 1179-2)
Process connection sealing	FKM (to DIN 3869)
Materials (wetted parts)	stainless steel (316L / 1.4404); Al2O3 (ceramics); FKM
Housing materials	stainless steel (316L / 1.4404); PBT+PC-GF 30; PBT-GF 20; PC
Switching cycles min.	100 million
Tightening torque [Nm]	25...35 (recommended tightening torque ²)
Restrictor element integrated	no (can be retrofitted)
Weight [kg]	0.263

Displays / operating elements	
Display	Display unit 3 x LED green (bar, psi, MPa) Switching status 2 x LED yellow 4-digit alphanumeric display / alternating indication Measured values of red and green

Electrical connection	
Connection	M12 connector; gold-plated contacts

Wiring

- Core colors
- BK black
 - BN brown
 - BU blue
 - WH white

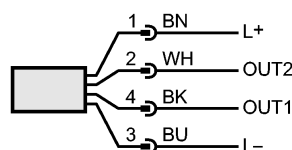

OUT1: switching output or IO-Link
 OUT2: switching output or 4...20 mA / 0...10 V
 Colours to DIN EN 60947-5-2



PN2569

PN-+,5BRER14-MFRKG/US/ IV



Pressure sensors

Remarks

Remarks

- *) BFSL = Best Fit Straight Line / LS = Limit Value Setting
- ***) with temperature fluctuations < 10 K
- ***) in% of the span / 6 months
- 1) to EN50178, SELV, PELV
- 2) Depends on lubrication, seal and pressure rating

Pack quantity

[piece]

1