

PILOT OPERATED CHECK VALVE POPPET TYPE,
PILOT TO OPEN, 3 TO 1 PILOT RATIO.

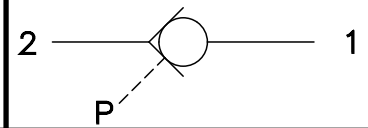

TORQUE:

Steel = 35/40 Ft-Lb. [47/54 Nm]
Aluminum = 25/30 Ft-Lb. [34/41 Nm]

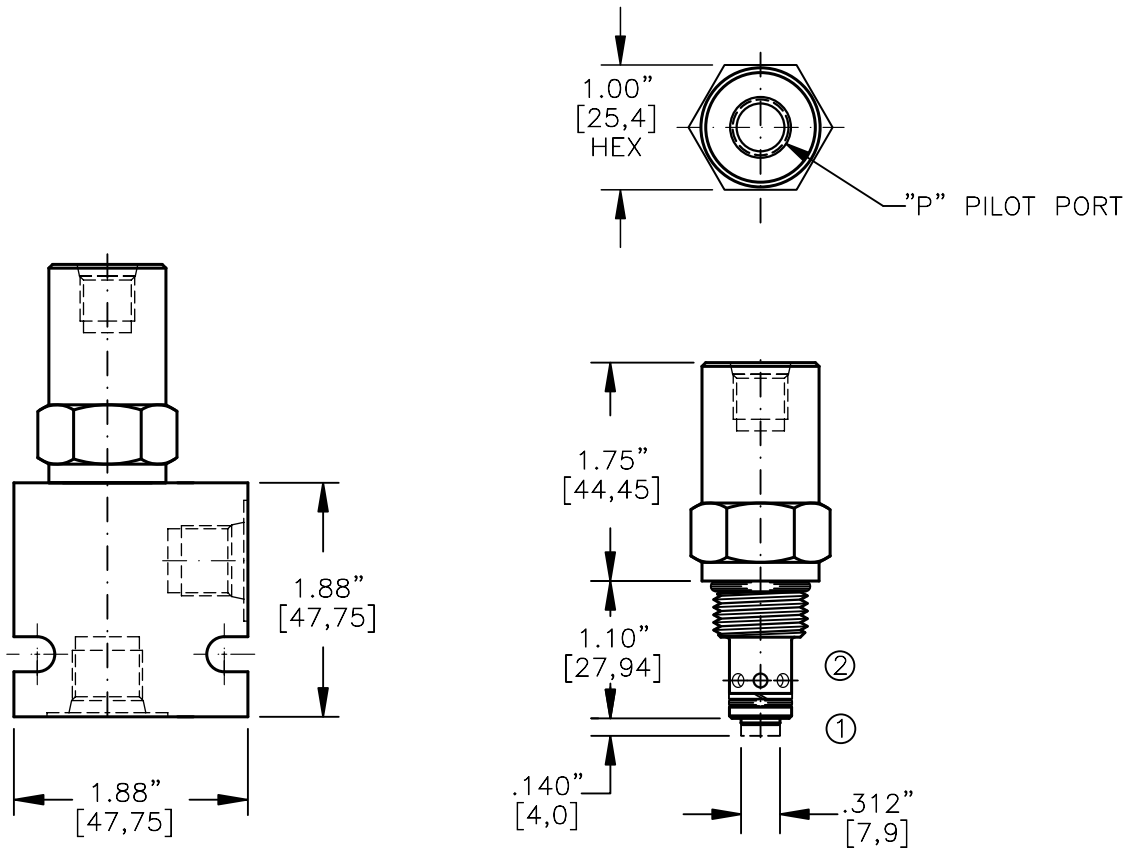

NOTE: CAVITY BOTTOM HOLE MUST ALLOW FOR POPPET EXTENSION (.500 DIA.).
FOR ALUMINUM OR STEEL VALVE HOUSING CONFIGURATIONS SEE PAGE 0-011.1

POCX-08-X-X-4T-XXX

- BASIC
- SIZE
08 = 3/4"-16 UNF
- SEALS
N = BUNA "N"
V = VITON
- PORTS
0 = CARTRIDGE ONLY
02BX = G 1/4" BSPB
06TX = SAE - #6
- "A" - ALUM. HOUSING
"S" - STEEL HOUSING
- CRACK PRESSURE
030 = 30 PSI
060 = 60 PSI
120 = 120 PSI
- "P" PILOT PORT
4T = SAE - #4

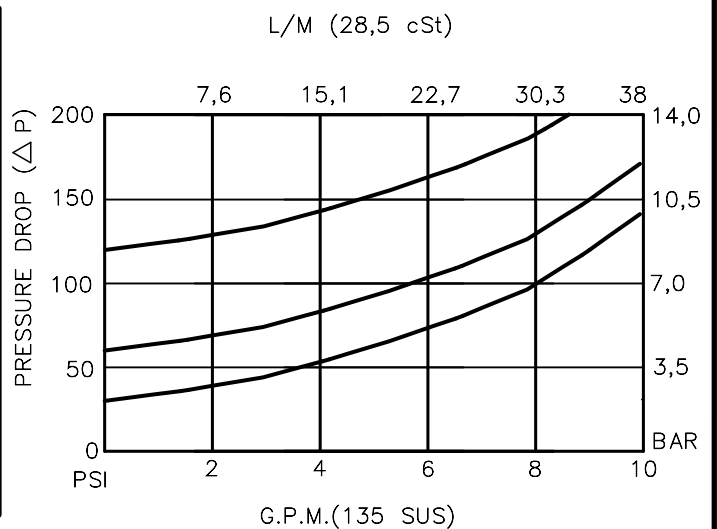

PILOT OPERATED CHECK VALVE POPPET TYPE, PILOT TO OPEN, 3 TO 1 PILOT RATIO

DESCRIPTION

This unit is a SCREW IN, cartridge type, guided poppet, hydraulic pilot operated check valve, for use as a blocking or load holding device for high pressure applications.

OPERATIONS

This valve allows free flow from port 2 to port 1 and blocks flow from port 1 to port 2 or holding a load. Flow will be allowed from port 1 to port 2 when pressure is applied to pilot port "P". This pilot operated check valve has a 3 to 1 pilot ratio, meaning that it takes at least one-third of the load pressure held at port 1 that is required at pilot port "P" to open the valve.

We recommend to use an orifice to dampen the pilot signal (X) when used with an on/off (hard shifting) valve.

FEATURES AND BENEFITS

Wide selection of bias springs allows flexibility for back-pressure application.

A low friction seal on pilot piston is standard.

All external carbon steel parts are plated for longer life against the elements.

All cartridge valves are 100% functionally tested.

Industry common cavity.

SPECIFICATIONS

OPERATING PRESSURE: 5,000 PSI [350 Bar]

PROOF PRESSURE: 10,000 PSI [700 Bar]

FLOW: 10.0 GPM [38,0 l/m] nominal. See performance chart.

PILOT RATIO: 3 TO 1

INTERNAL LEAKAGE: 5 drops per minute maximum @ 5,000 PSI [350 Bar]

VALVE HOUSINGS: 2500 PSI [175 Bar] = Aluminum - Anodized.

5000 PSI [350 Bar] = Steel - Unplated.

OPERATING TEMPERATURE: -40° to +250° F. [-40° to +120° C.]

OPERATING MEDIA: All general purpose hydraulic fluids such as MIL-H-5606, SAE-#10, SAE-#20, etc.

INSTALLATION: No restrictions.

SEAL KIT: SKN-0821 Buna "N"

SKV-0821 Viton

WEIGHT: .34 lb [.15 kg] cartridge only.

VALVE CAVITY: #C0820, See Page 0-011.0.

info.el@bucherhydraulics.com

www.bucherhydraulics.com/commoncavity

© 2015 by Bucher Hydraulics, Inc., 2545 Northwest Parkway, Elgin, Illinois 60124, USA

All rights reserved.

Data is provided for the purpose of product description only, and must not be construed as warranted characteristics in the legal sense. The information does not relieve users from the duty of conducting their own evaluations and tests. Because the products are subject to continual improvement, we reserve the right to amend the product specifications contained in this catalogue.

PILOT OPERATED CHECK VALVE POPPET TYPE,
PILOT TO OPEN, 3 TO 1 PILOT RATIO.

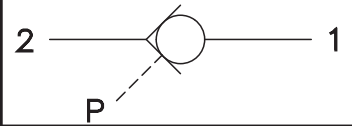

TORQUE:

Steel = 55/60 Ft-Lb. [74/81 Nm]
Aluminum = 35/40 Ft-Lb. [47/54 Nm]

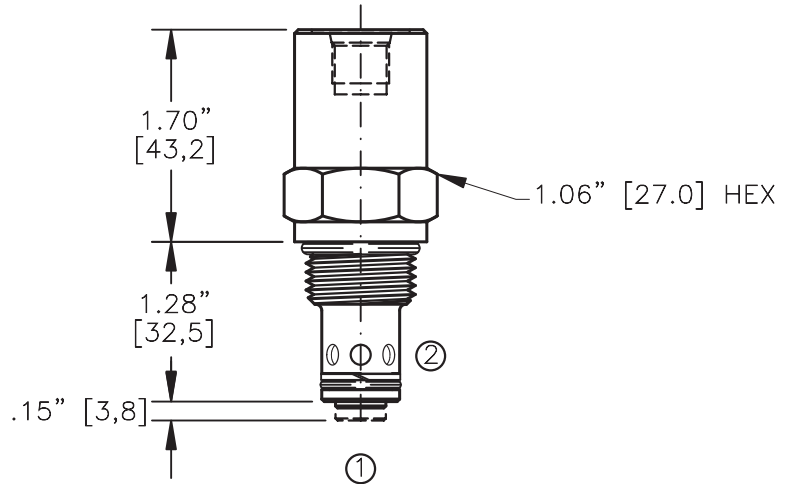
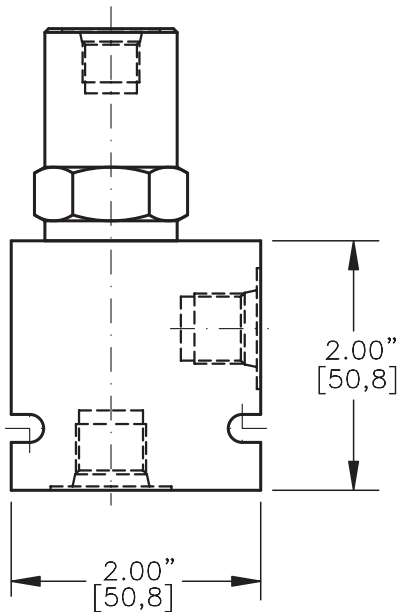
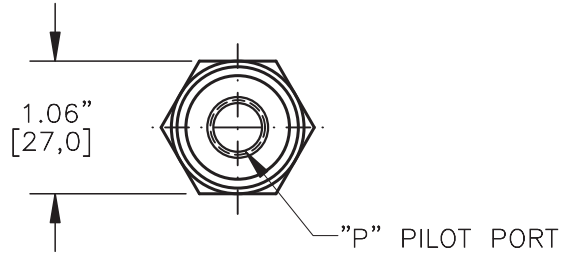

NOTE: CAVITY BOTTOM HOLE MUST ALLOW FOR POPPET EXTENSION (.563 DIA.).
FOR ALUMINUM OR STEEL VALVE HOUSING CONFIGURATIONS SEE PAGE 0-012.1

POCX-10-X-X-XX-XXX

BASIC

SIZE

10 = 7/8"-14 UNF

SEALS

N = BUNA "N"
V = VITON

PORTS

0 = CARTRIDGE ONLY
02BX = G 1/4" BSPP
03BX = G 3/8" BSPP
06TX = SAE - #6
08TX = SAE - #8

"A" - ALUM. HOUSING
"S" - STEEL HOUSING

CRACK PRESSURE

030 = 30 PSI
060 = 60 PSI
120 = 120 PSI

"P" PILOT PORT

2B = G 1/4" BSPP
4T = SAE - #4

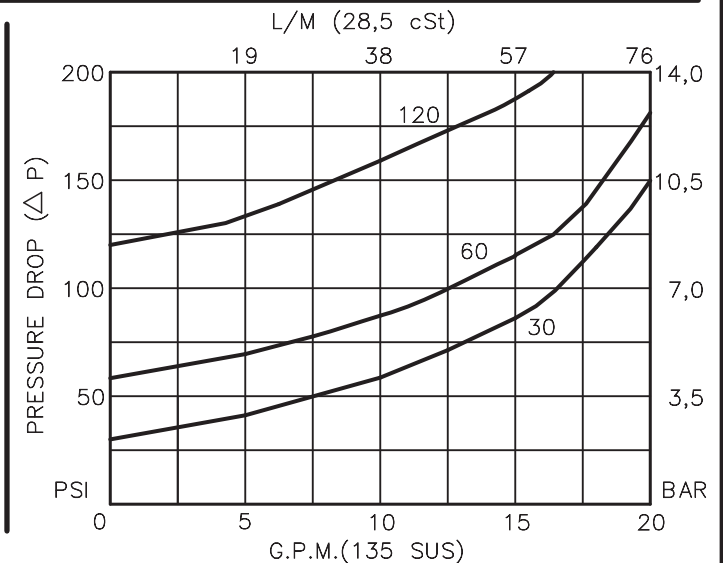

PILOT OPERATED CHECK VALVE

POPPET TYPE, PILOT TO OPEN, 3 TO 1 PILOT RATIO.

DESCRIPTION

This unit is a SCREW IN, cartridge type, guided poppet, hydraulic pilot operated check valve, for use as a blocking or load holding device for high pressure applications.

OPERATIONS

This valve allows free flow from port 2 to port 1 and blocks flow from port 1 to port 2 or holding a load. Flow will be allowed from port 1 to port 2 when pressure is applied to pilot port "P". This pilot operated check valve has a 3 to 1 pilot ratio, meaning that it takes at least one-third of the load pressure held at port 1 that is required at pilot port "P" to open the valve. We recommend to use an orifice to dampen the pilot signal (X) when used with an on/off (hard shifting) valve.

FEATURES AND BENEFITS

Wide selection of bias springs allows flexibility for back-pressure application.
A low friction seal on pilot piston is standard.
All external carbon steel parts are plated for longer life against the elements.
All cartridge valves are 100% functionally tested.
Industry common cavity.

SPECIFICATIONS

OPERATING PRESSURE: 5,000 PSI [350 Bar]
 PROOF PRESSURE: 10,000 PSI [700 Bar]
 FLOW: 18.0 GPM [70 l/m] nominal. See performance chart.
 PILOT RATIO: 3 TO 1
 INTERNAL LEAKAGE: 5 drops per minute maximum @ 5,000 PSI [350 Bar]
 VALVE HOUSINGS: 2500 PSI [175 Bar] = Aluminum - Anodized.
 5000 PSI [350 Bar] = Steel - Unplated.
 OPERATING TEMPERATURE: -40° to +250° F. [-40° to +120° C.]
 OPERATING MEDIA: All general purpose hydraulic fluids such as
 MIL-H-5606, SAE-#10, SAE-#20, etc.
 INSTALLATION: No restrictions.
 SEAL KIT: SKN-1021 Buna "N"
 SKV-1021 Viton
 WEIGHT: .31 lb [.14 kg] cartridge only.
 VALVE CAVITY: #C 1020, See Page 0-012.0.

info.el@bucherhydraulics.com

www.bucherhydraulics.com/commoncavity

© 2015 by Bucher Hydraulics, Inc., 2545 Northwest Parkway, Elgin, Illinois 60124, USA

All rights reserved.

Data is provided for the purpose of product description only, and must not be construed as warranted characteristics in the legal sense. The information does not relieve users from the duty of conducting their own evaluations and tests. Because the products are subject to continual improvement, we reserve the right to amend the product specifications contained in this catalogue.

PILOT OPERATED CHECK VALVE POPPET TYPE,
PILOT TO OPEN, 3 TO 1 PILOT RATIO.

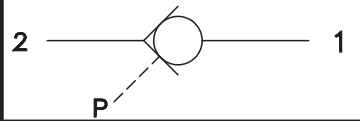

TORQUE:

Steel = 70/75 Ft-Lb. [95/102 Nm]
Aluminum = 55/60 Ft-Lb. [74/81 Nm]

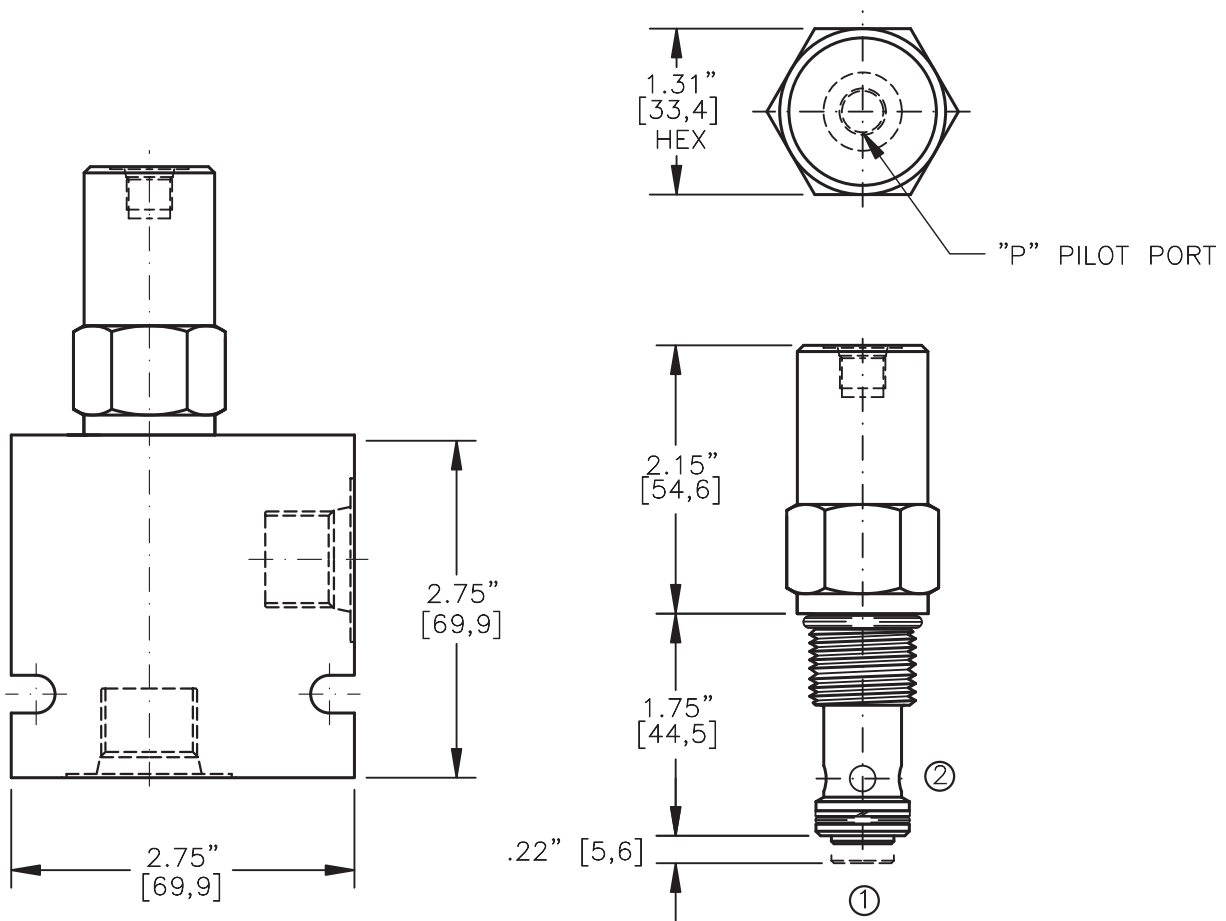

NOTE: CAVITY BOTTOM HOLE MUST ALLOW FOR POPPET EXTENSION(.630 DIA.).
FOR ALUMINUM OR STEEL VALVE HOUSING CONFIGURATIONS SEE PAGE 0-013.1

POCX-12-X-X-XX-XXX

- BASIC
- SIZE
12 = 1.062"-12 UNF
- SEALS
N = BUNA "N"
V = VITON
- PORTS
0 = CARTRIDGE ONLY
04BX = G 1/2" BSPP
06BX = G 3/4" BSPP
10TX = SAE - #10
12TX = SAE - #12
- "A" - ALUM. HOUSING
"S" - STEEL HOUSING
- CRACK PRESSURE
030 = 30 PSI
060 = 60 PSI
120 = 120 PSI
- "P" PILOT PORT
2B = G 1/4" BSPP
4T = SAE - #4

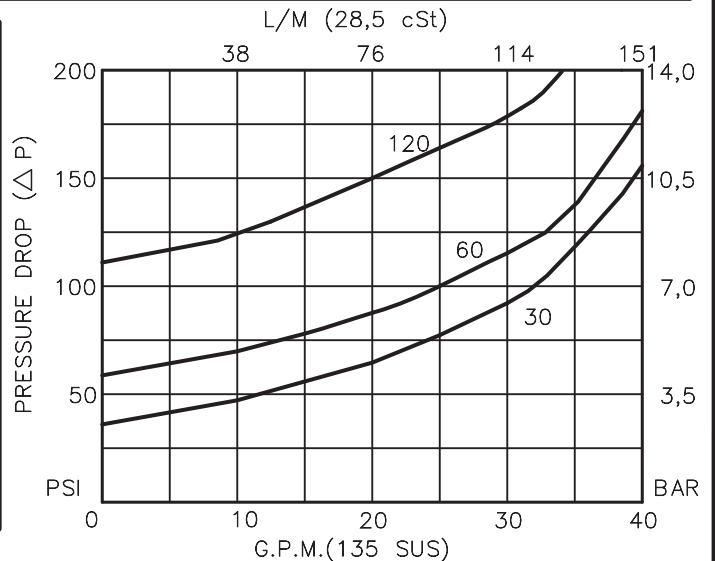

PILOT OPERATED CHECK VALVE**POPPET TYPE, PILOT TO OPEN, 3 TO 1 PILOT RATIO.****DESCRIPTION**

This unit is a SCREW IN, cartridge type, guided poppet, hydraulic pilot operated check valve, for use as a blocking or load holding device for high pressure applications.

OPERATIONS

This valve allows free flow from port 2 to port 1 and blocks flow from port 1 to port 2 or holding a load. Flow will be allowed from port 1 to port 2 when sufficient pilot pressure is applied to port "P". This pilot operated check valve has a 3 to 1 pilot ratio, meaning that it takes at least one-third of the load pressure held at port 1 that is required at pilot port "P" to open the valve.

We recommend to use an orifice to dampen the pilot signal (X) when used with an on/off (hard shifting) valve.

FEATURES AND BENEFITS

Wide selection of bias springs allows flexibility for back-pressure application.

A low friction seal on pilot piston is standard.

All external carbon steel parts are plated for longer life against the elements.

All cartridge valves are 100% functionally tested.

Industry common cavity.

SPECIFICATIONS

OPERATING PRESSURE: 5,000 PSI [350 Bar]

PROOF PRESSURE: 10,000 PSI [700 Bar]

FLOW: 35.0 GPM [132,5 l/m] nominal. See performance chart.

PILOT RATIO: 3 TO 1

INTERNAL LEAKAGE: 5 drops per minute maximum @ 5,000 PSI [350 Bar]

VALVE HOUSINGS: 2500 PSI [175 Bar] = Aluminum - Anodized.

5000 PSI [350 Bar] = Steel - Unplated.

OPERATING TEMPERATURE: -40° to +250° F. [-40° to +120° C.]

OPERATING MEDIA: All general purpose hydraulic fluids such as MIL-H-5606, SAE-#10, SAE-#20, etc.

INSTALLATION: No restrictions.

SEAL KIT: SKN-1221 Buna "N"

SKV-1221 Viton

WEIGHT: 0.31 lb [0,14 kg] cartridge only.

VALVE CAVITY: #C1220, See Page 0-013.0.

info.el@bucherhydraulics.com

www.bucherhydraulics.com/commoncavity

© 2015 by Bucher Hydraulics, Inc., 2545 Northwest Parkway, Elgin, Illinois 60124, USA

All rights reserved.

Data is provided for the purpose of product description only, and must not be construed as warranted characteristics in the legal sense. The information does not relieve users from the duty of conducting their own evaluations and tests. Because the products are subject to continual improvement, we reserve the right to amend the product specifications contained in this catalogue.