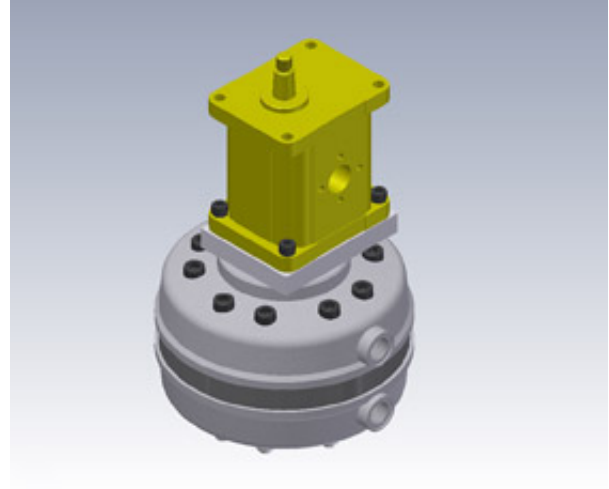
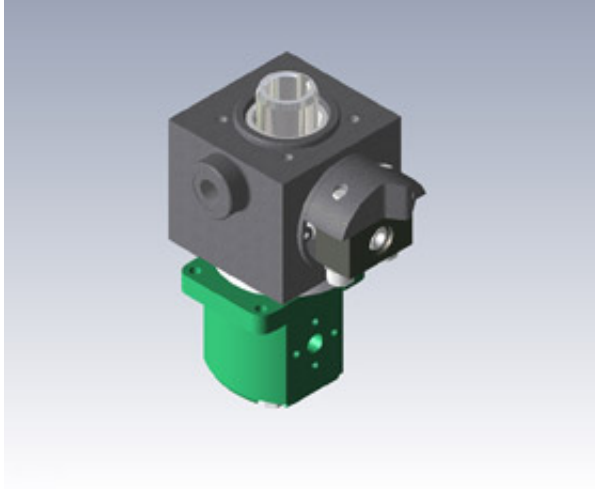

MULTIPLE PUMP - GENERAL INFORMATION

The High Pressure fixed-displacement radial piston pumps PR Series are designed to specifically satisfy the industrial machinery market where a high pressure or two stage high-low pressure pump is required.

In the PR pumps the pumping cylinders, with intake and delivery valves, are put in star-shape around a cam which, with the help of the plunger return springs, supply with the suction and pressing reciprocating motion.

The plungers' measures are five, therefore the smallest ones consent higher pressures and the biggest ones supply major flow rates.

The pumping cylinders (as the relative valves), are of modular conception, are easily replaceable and can be changed with others of different bore if necessary to modify the pump characteristics.

Being suitable for oil-submersed or external installation and with different types of shafts, the pumps PR allow many kinds of installation possibilities, even to be coupled with gear pumps.

Thanks to the reliability and versatility of our radial piston pumps of PR series, we produce multiple high-low pressure pumps coupled with gear pumps or vane pumps.

This kind of combination is ideal for presses, filter-presses and all the machinery that require a quick initial approach and a high work pressure, but limiting the size of the required drive motor.

Our double pumps are constituted by a gear pump (Low Pressure) connected by coupling to the motor and by a radial piston pump (High-Pressure) assembled in tandem.

Only for model with Gr1 gear pump, they are installed on the back of the radial pump.

It is possible to obtain special combinations on request and according to the customer's specific requests.

Always make sure that the torque applied is less than or equal to the admissible torque of the shaft.

MULTIPLE PUMP PR 1 - 2 - 3 + Gear Pump Gr 1 - TECHNICAL SPECIFICATION

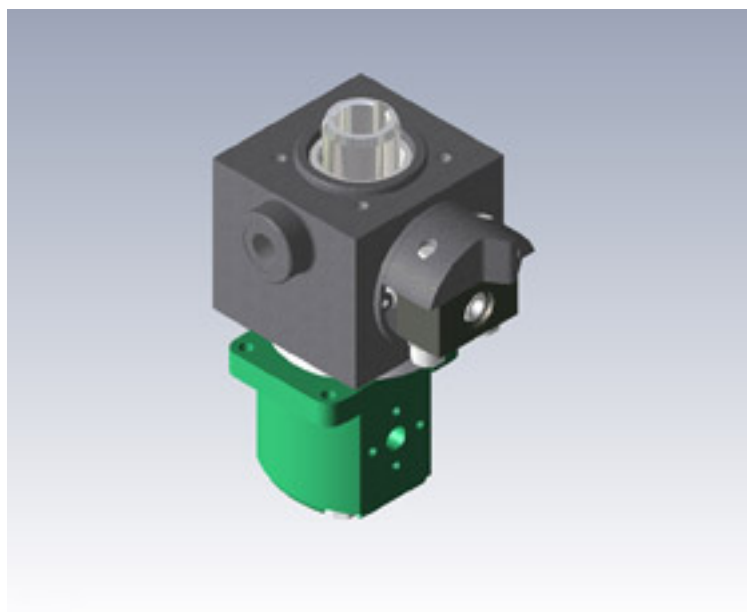

N° of Pistons	Pump Type	Piston Pump			Gear Pump Gr 1		Rated Speed n/min.	Speed Range n/min. (*)
		Displacement cm ³ / n	Rated Pressure bar	Peak Pressure bar	Displacement cm ³ / n	Pressure Range bar		
1	PR 1.08	0,40	600	650	0,9 - 9,8	240 - 150	1500	700 - 1800
	PR 1.10	0,63	500	550				
	PR 1.12	0,91	350	390				
	PR 1.13	1,06	300	340				
	PR 1.14	1,23	250	280				
2	PR 2.08	0,80	600	650				
	PR 2.10	1,26	500	550				
	PR 2.12	1,81	350	390				
	PR 2.13	2,12	300	340				
	PR 2.14	2,46	250	280				
3	PR 3.08	1,20	600	650				
	PR 3.10	1,90	500	550				
	PR 3.12	2,72	350	390				
	PR 3.13	3,18	300	340				
	PR 3.14	3,69	250	280				

(*) For good performances, the minimum speed of the gear pump should not be less than 700 n/min.

MULTIPLE PUMP PR 1 + Gear Pump Gr 1 - INSTALLATION DRAWING

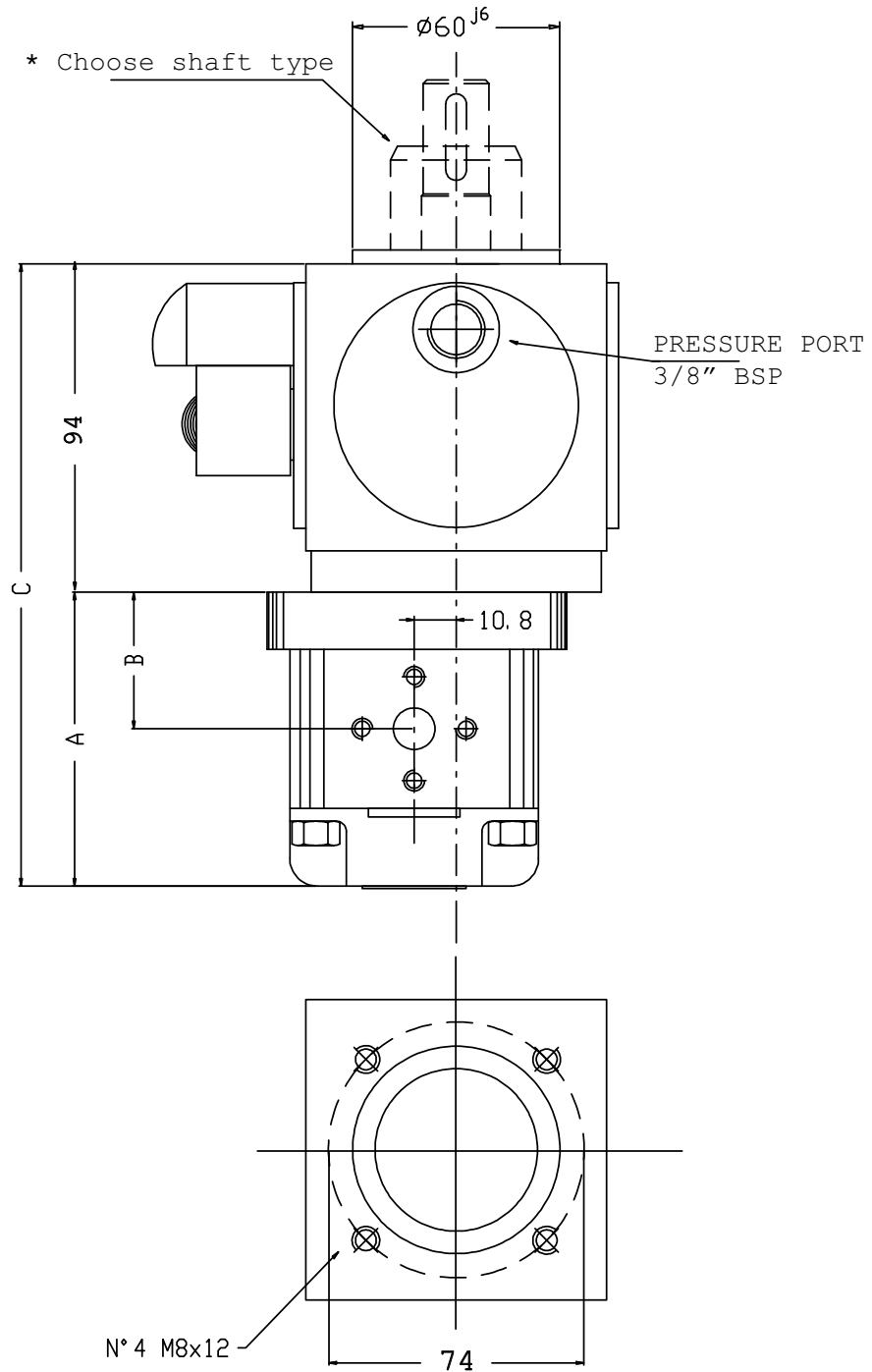

MULTIPLE PUMP PR 2 + Gear Pump Gr 1 - INSTALLATION DRAWING

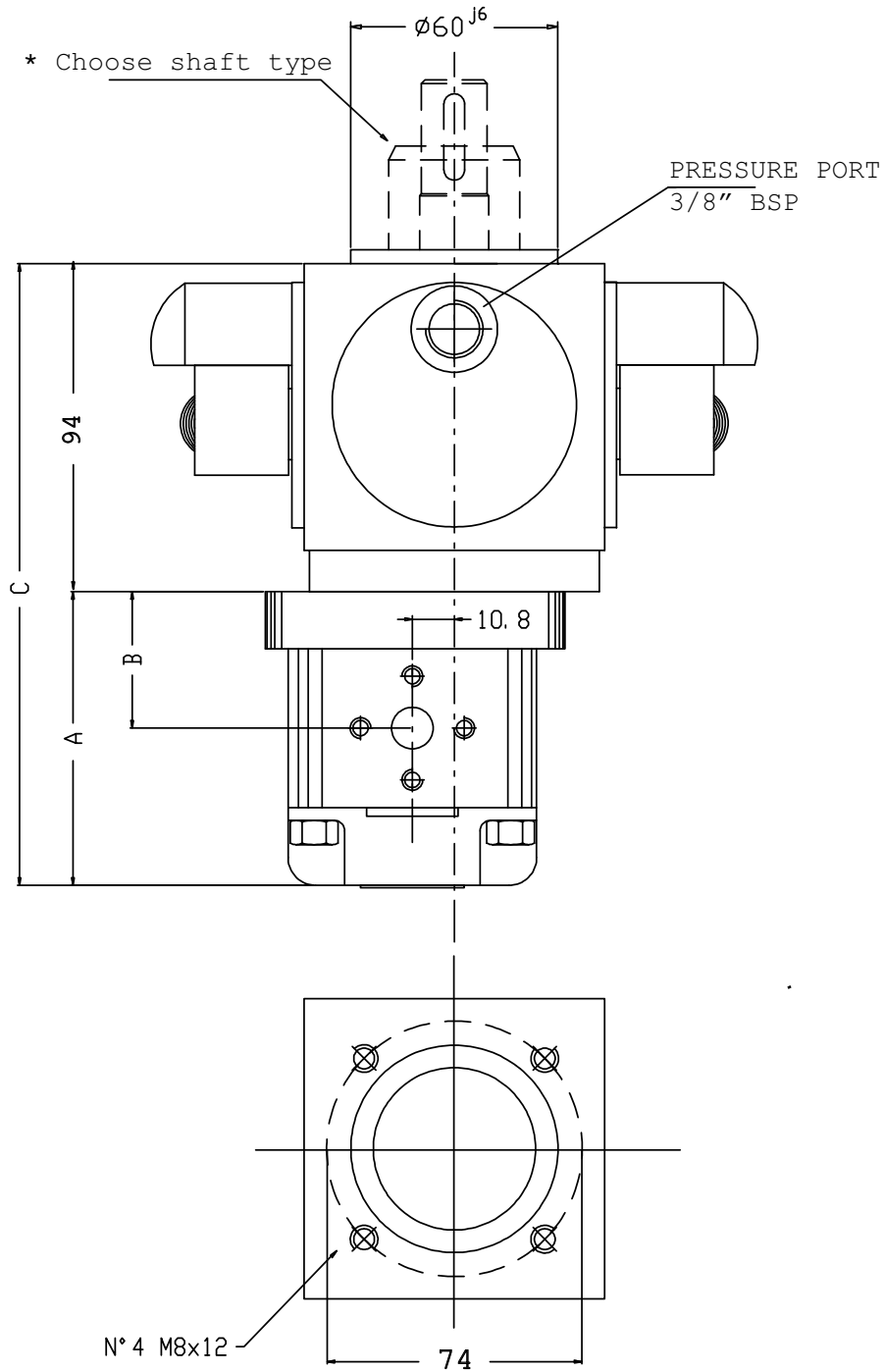

MULTIPLE PUMP PR 3 + Gear Pump Gr 1 - INSTALLATION DRAWING

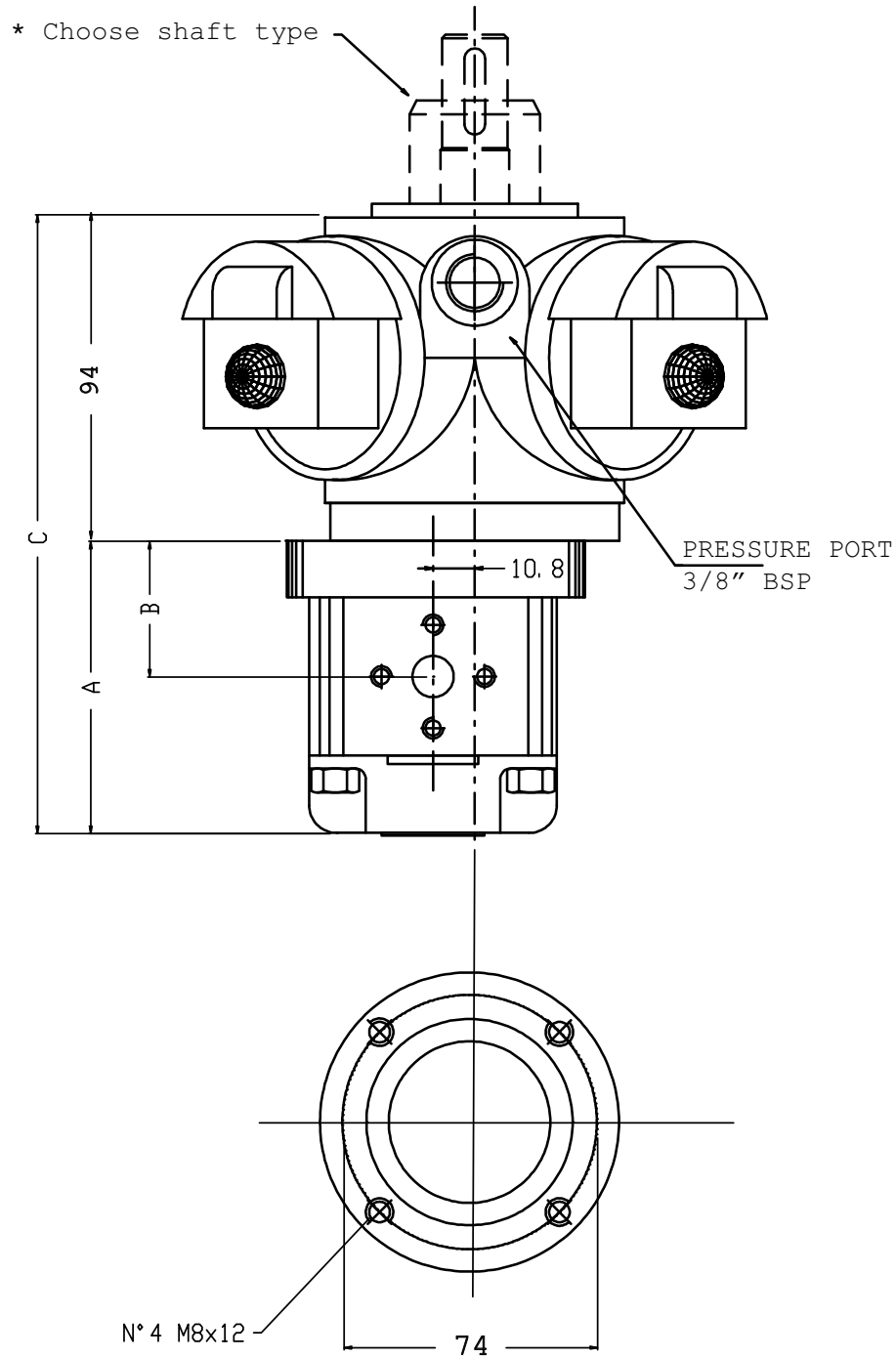

MULTIPLE PUMP PR 1 - 2 - 3 + Gear Pump Gr 2 - TECHNICAL SPECIFICATION

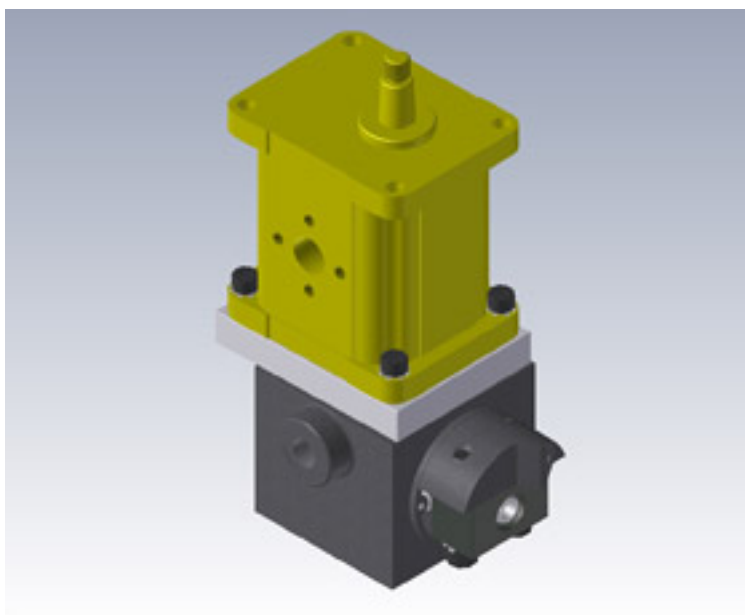

N° of Pistons	Pump Type	Piston Pump			Gear Pump Gr 2		Rated Speed n/min.	Speed Range n/min. (*)
		Displacement cm ³ /n	Rated Pressure bar	Peak Pressure bar	Displacement cm ³ /n	Pressure Range bar		
1	PR 1.08	0,40	600	650	4 - 40	280 - 170	1500	700 - 1800
	PR 1.10	0,63	500	550				
	PR 1.12	0,91	350	390				
	PR 1.13	1,06	300	340				
	PR 1.14	1,23	250	280				
2	PR 2.08	0,80	600	650				
	PR 2.10	1,26	500	550				
	PR 2.12	1,81	350	390				
	PR 2.13	2,12	300	340				
	PR 2.14	2,46	250	280				
3	PR 3.08	1,20	600	650				
	PR 3.10	1,90	500	550				
	PR 3.12	2,72	350	390				
	PR 3.13	3,18	300	340				
	PR 3.14	3,69	250	280				

(*) For good performances, the minimum speed of the gear pump should not be less than 700 n/min.

Always make sure that the torque applied is less than or equal to the admissible torque of the shaft

MULTIPLE PUMP PR 1 + Gear Pump Gr 2 - INSTALLATION DRAWING

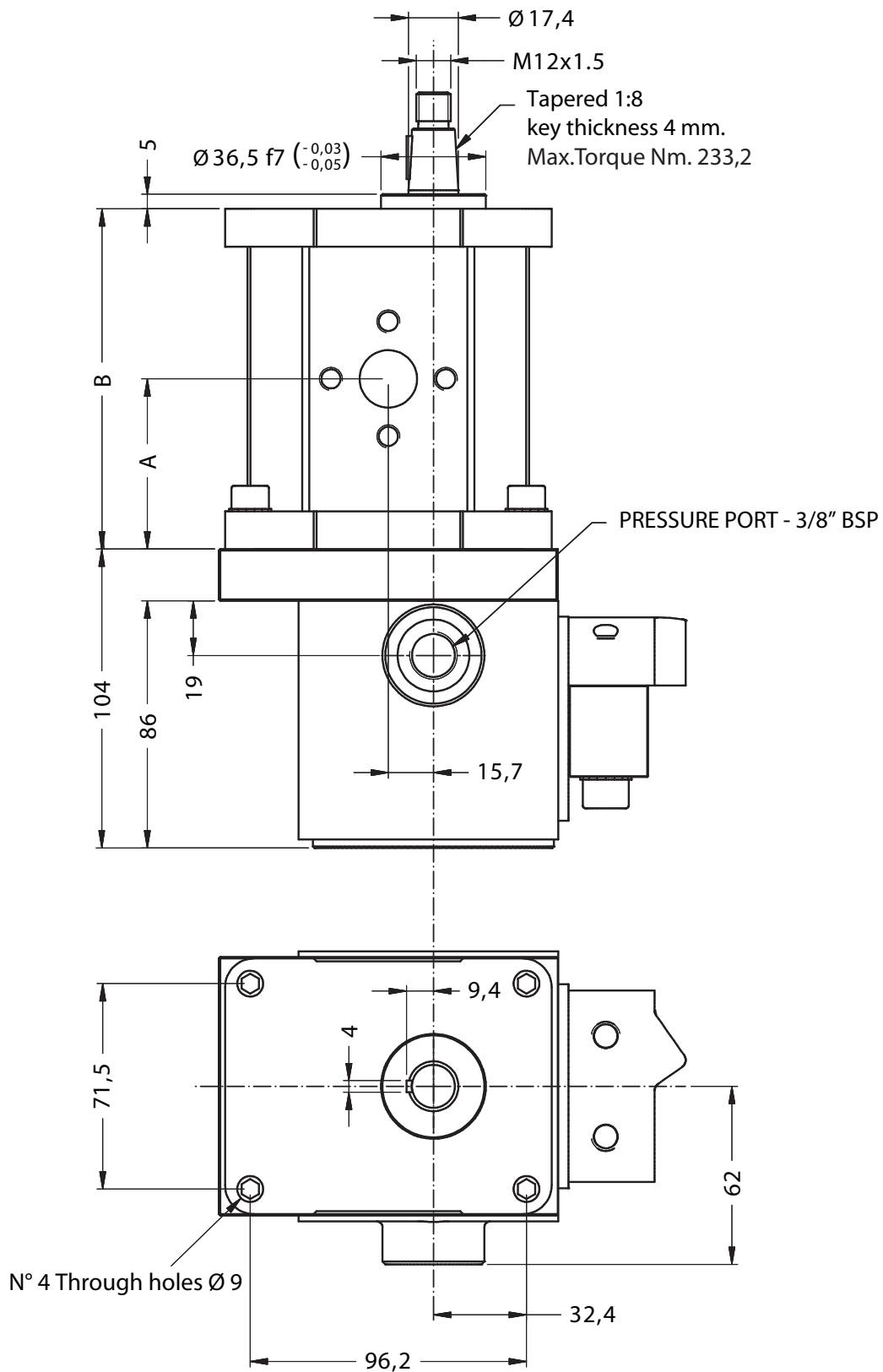

Always make sure that the torque applied is less than or equal to the admissible torque of the shaft

MULTIPLE PUMP PR 2 + Gear Pump Gr 2 - INSTALLATION DRAWING

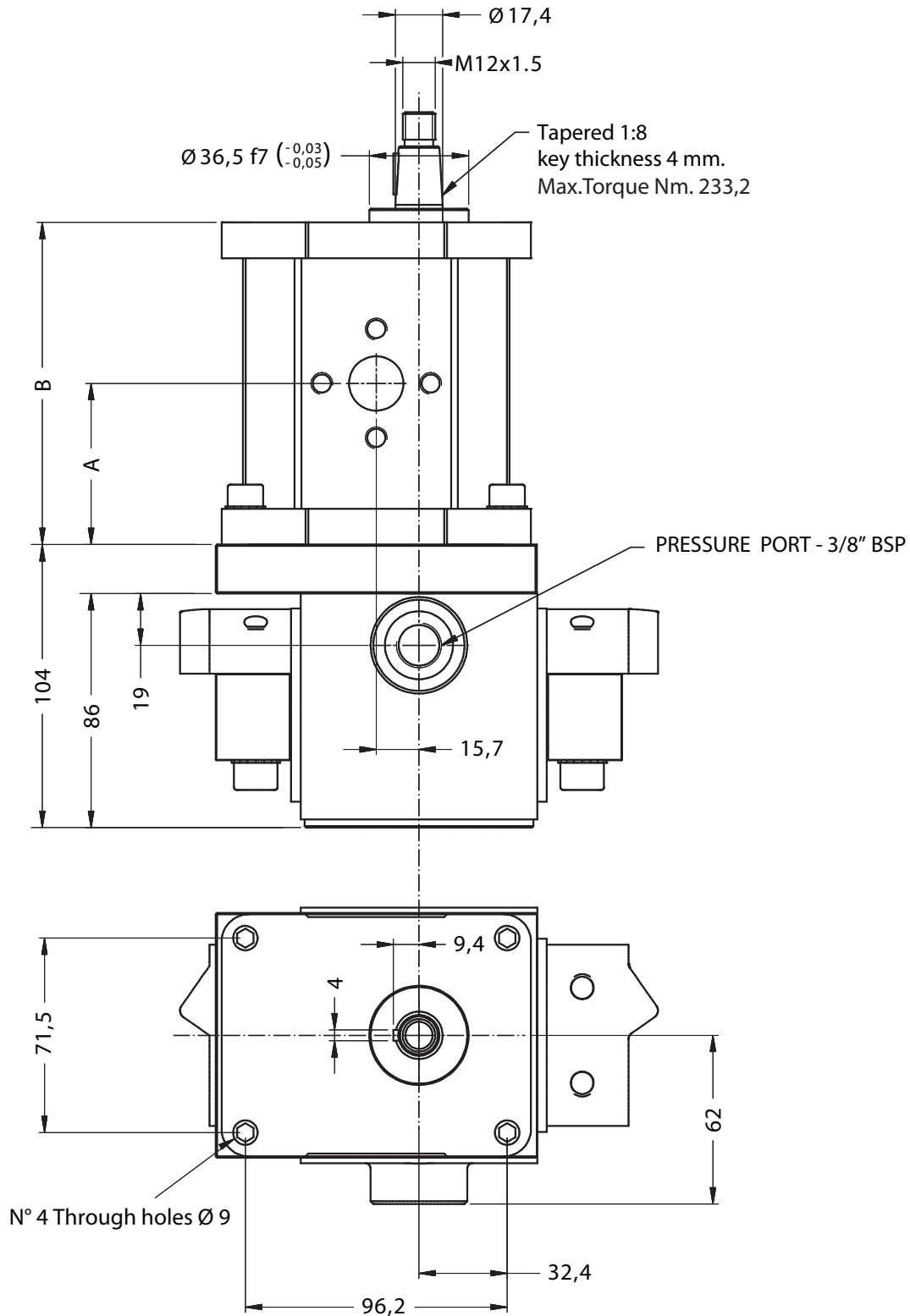

Always make sure that the torque applied is less than or equal to the admissible torque of the shaft.

MULTIPLE PUMP PR 3 + Gear Pump Gr 2 - INSTALLATION DRAWING

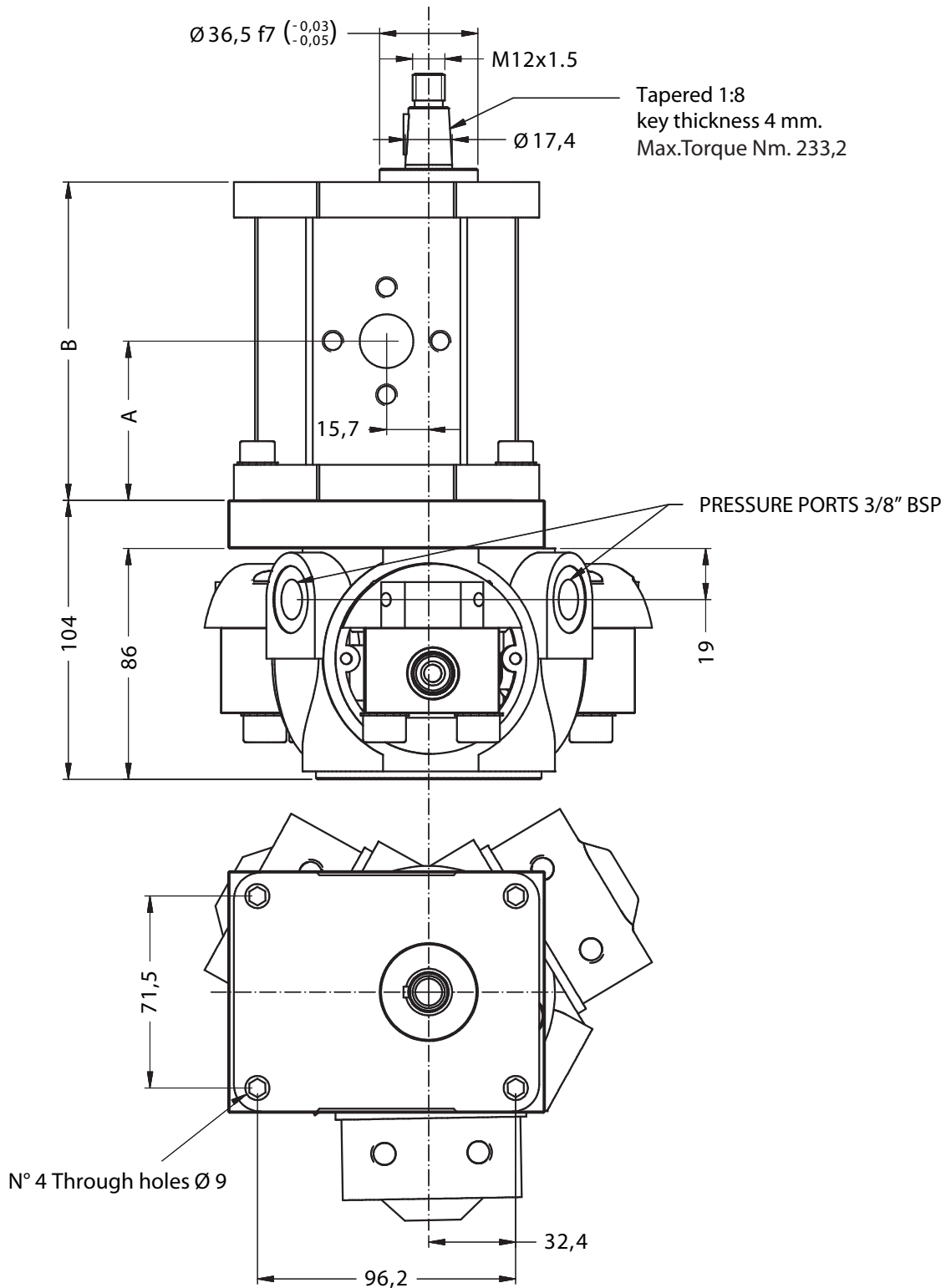

Always make sure that the torque applied is less than or equal to the admissible torque of the shaft.

MULTIPLE PUMP PR 1 - 2 - 3 + Gear Pump Gr 3 - TECHNICAL SPECIFICATION

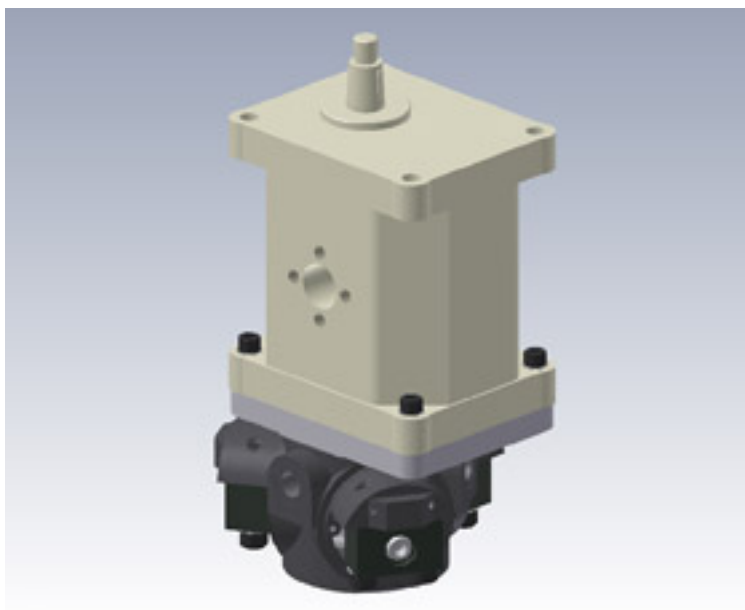

N° of Pistons	Pump Type	Piston Pump			Gear Pump Gr 3		Rated Speed n/min.	Speed Range n/min. (*)
		Displacement cm ³ /n	Rated Pressure bar	Peak Pressure bar	Displacement cm ³ /n	Pressure Range bar		
1	PR 1.08	0,40	600	650	22 - 90	270 - 180	1500	700 - 1800
	PR 1.10	0,63	500	550				
	PR 1.12	0,91	350	390				
	PR 1.13	1,06	300	340				
	PR 1.14	1,23	250	280				
2	PR 2.08	0,80	600	650				
	PR 2.10	1,26	500	550				
	PR 2.12	1,81	350	390				
	PR 2.13	2,12	300	340				
	PR 2.14	2,46	250	280				
3	PR 3.08	1,20	600	650				
	PR 3.10	1,90	500	550				
	PR 3.12	2,72	350	390				
	PR 3.13	3,18	300	340				
	PR 3.14	3,69	250	280				

(*) For good performances, the minimum speed of the gear pump should not be less than 700 n/min.

Always make sure that the torque applied is less than or equal to the admissible torque of the shaft.

MULTIPLE PUMP PR 1 + Gear Pump Gr 3 - INSTALLATION DRAWING

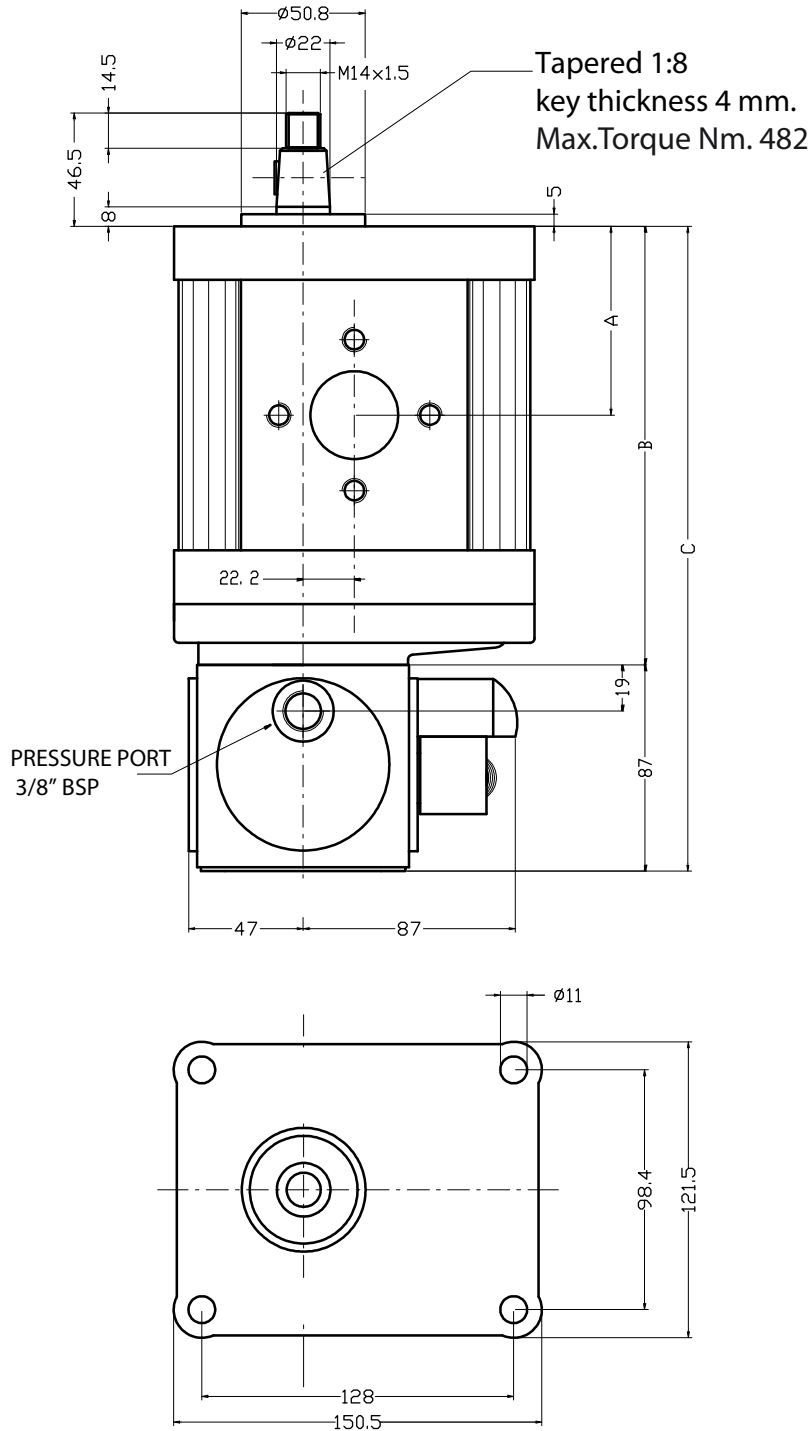

Always make sure that the torque applied is less than or equal to the admissible torque of the shaft.

MULTIPLE PUMP PR 2 + Gear Pump Gr 3 - INSTALLATION DRAWING

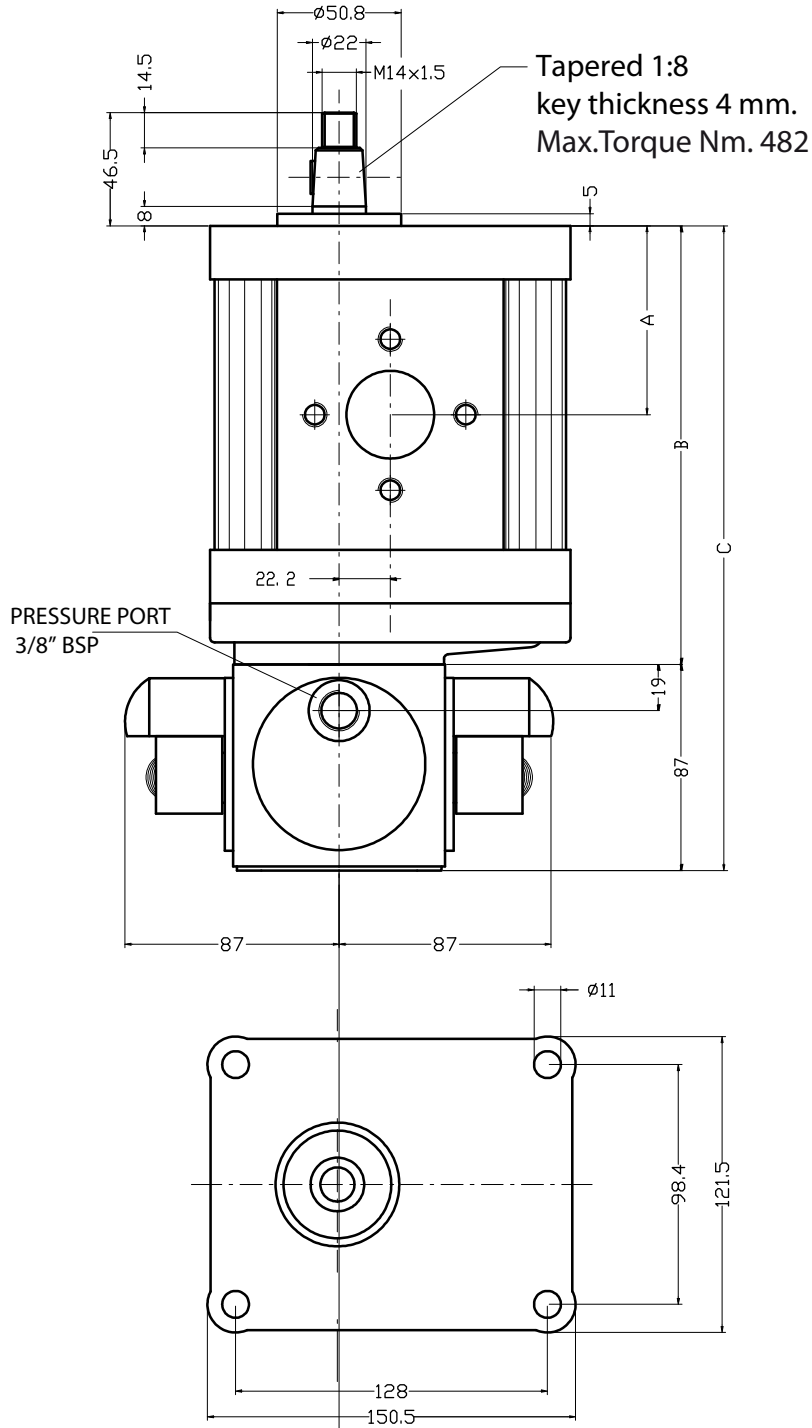

Always make sure that the torque applied is less than or equal to the admissible torque of the shaft.

MULTIPLE PUMP PR 3 + Gear Pump Gr 3 - INSTALLATION DRAWING

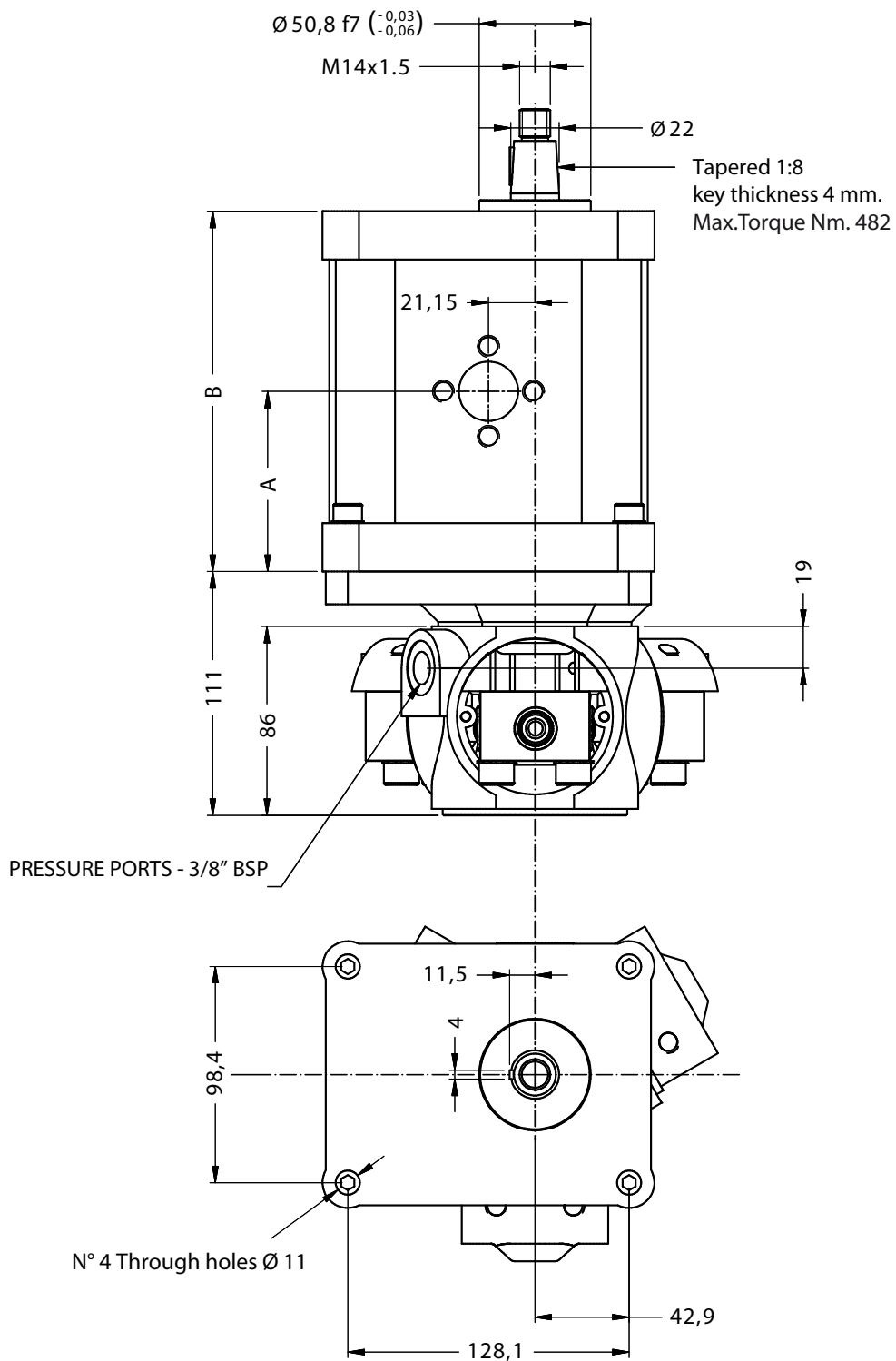

Always make sure that the torque applied is less than or equal to the admissible torque of the shaft.

MULTIPLE PUMP PR 5 - 7 + Gear Pump Gr 2 - TECHNICAL SPECIFICATION

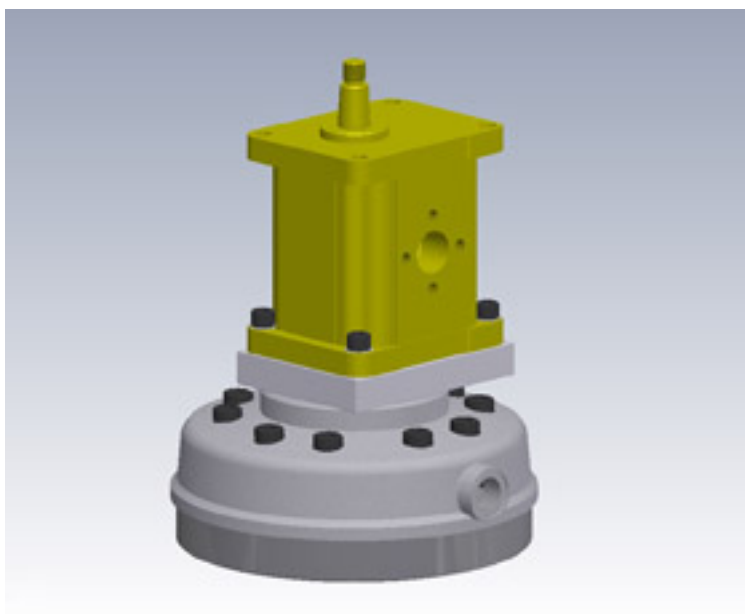

N° of Pistons	Pump Type	Piston Pump			Gear Pump Gr 2		Rated Speed n/min.	Speed Range n/min. (*)
		Displacement cm ³ / n	Rated Pressure bar	Peak Pressure bar	Displacement cm ³ / n	Pressure Range bar		
5	PR 5.10	3,50	500	550	4 - 40	280 - 170	1500	700 - 1800
	PR 5.12	4,45	350	390				
	PR 5.13	5,30	300	340				
	PR 5.14	6,15	250	280				
7	PR 7.10	4,41	500	550	4 - 40	280 - 170	1500	700 - 1800
	PR 7.12	7,10	350	390				
	PR 7.13	7,42	300	340				
	PR 7.14	8,61	250	280				

(*) For good performances, the minimum speed of the gear pump should not be less than 700 n/min.

Always make sure that the torque applied is less than or equal to the admissible torque of the shaft.

MULTIPLE PUMP PR 5 - 7 + Gear Pump Gr 2 - INSTALLATION DRAWING

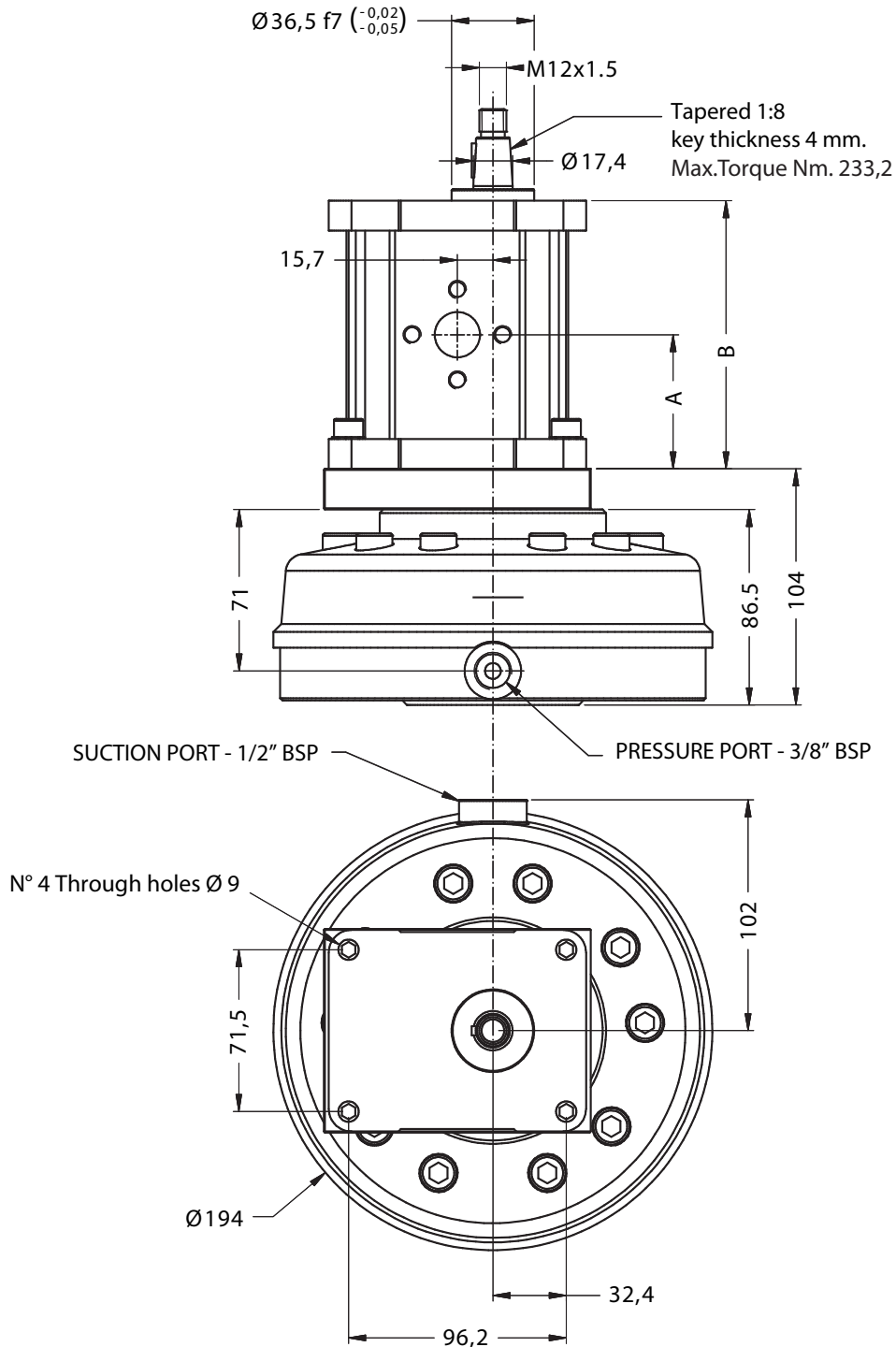

Always make sure that the torque applied is less than or equal to the admissible torque of the shaft.

MULTIPLE PUMP PR 5 - 7 + Gear Pump Gr 3 - TECHNICAL SPECIFICATION

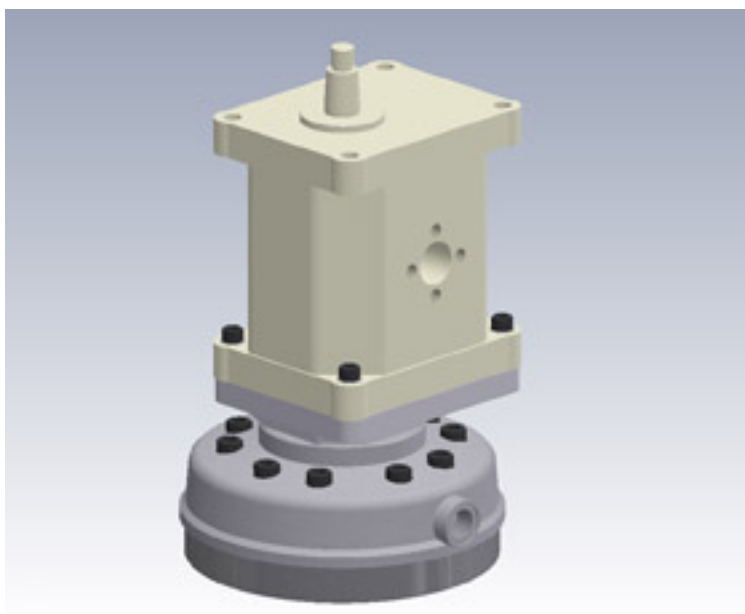

N° of Pistons	Pump Type	Piston Pump			Gear Pump Gr 3		Rated Speed n/min.	Speed Range n/min.
		Displacement cm ³ /n	Rated Pressure bar	Peak Pressure bar	Displacement cm ³ /n	Pressure Range bar		
5	PR 5.10	3,50	500	550	22 - 90	270 - 180	1500	300 - 1800
	PR 5.12	4,45	350	390				
	PR 5.13	5,30	300	340				
	PR 5.14	6,15	250	280				
7	PR 7.10	4,41	500	550	22 - 90	270 - 180	1500	300 - 1800
	PR 7.12	7,10	350	390				
	PR 7.13	7,42	300	340				
	PR 7.14	8,61	250	280				

(*) For good performances, the minimum speed of the gear pump should not be less than 700 n/min.

Always make sure that the torque applied is less than or equal to the admissible torque of the shaft.

MULTIPLE PUMP PR 5 - 7 + Gear Pump Gr 3 - INSTALLATION DRAWING

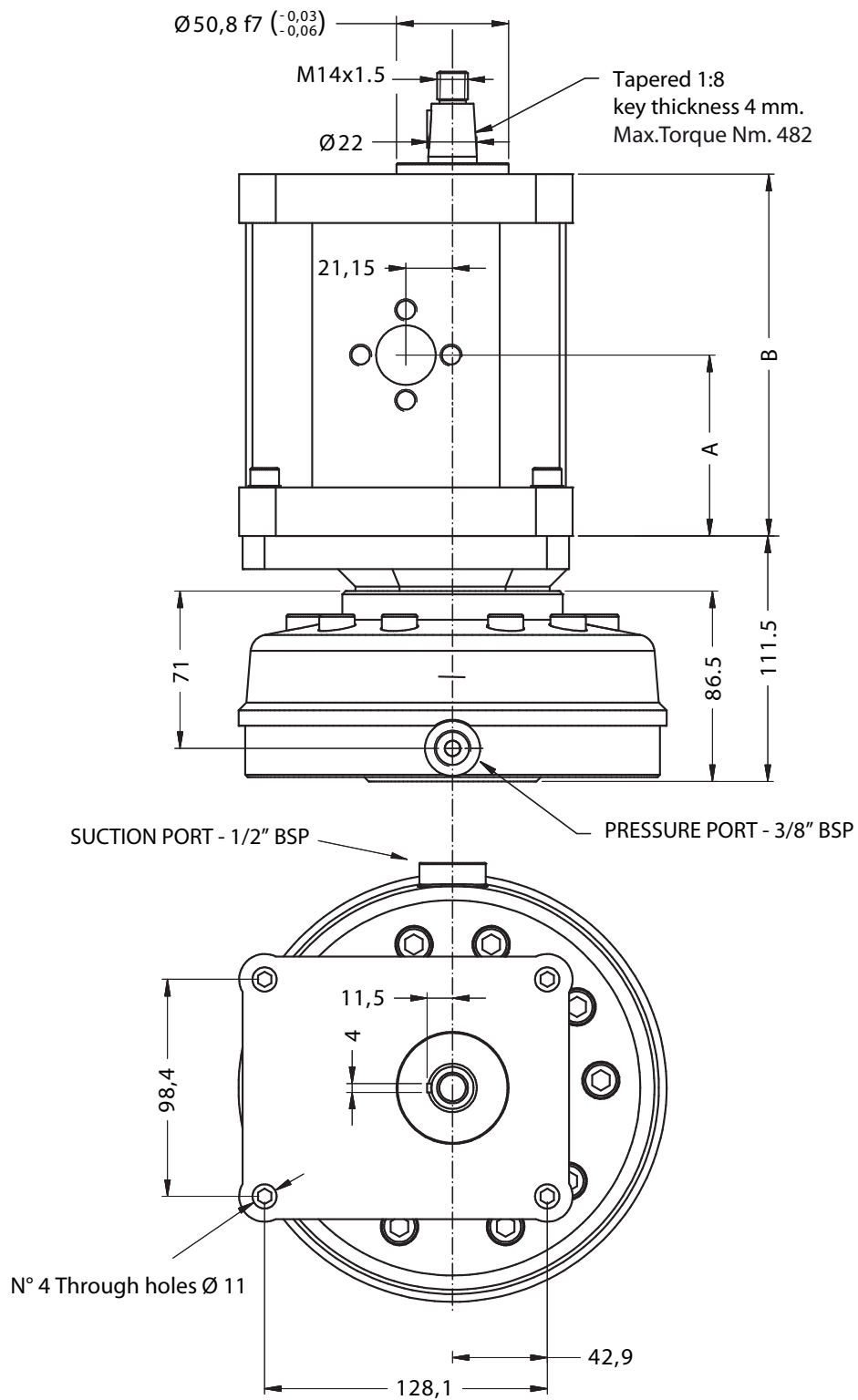

Always make sure that the torque applied is less than or equal to the admissible torque of the shaft.

MULTIPLE PUMP PR 10 - 14 + Gear Pump Gr 2 - TECHNICAL SPECIFICATION

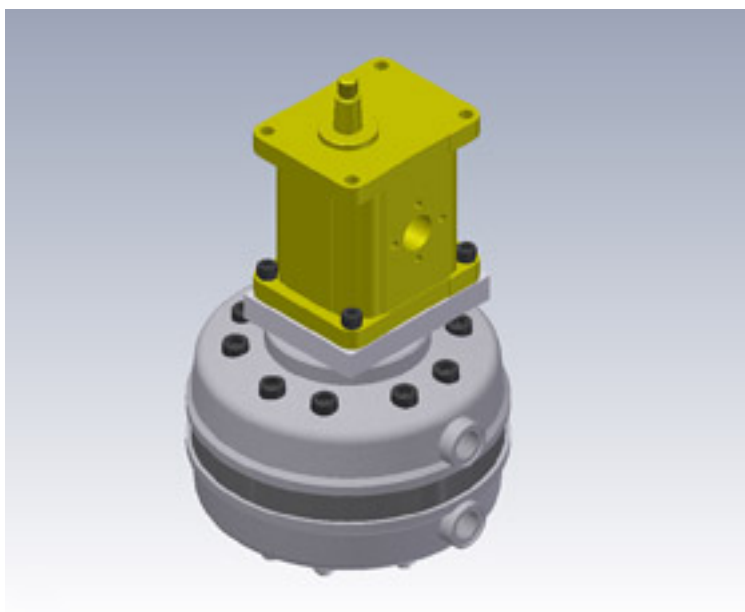

N° of Pistons	Pump Type	Piston Pump			Gear Pump Gr 2		Rated Speed n/min.	Speed Range n/min. (*)
		Displacement cm ³ / n	Rated Pressure bar	Peak Pressure bar	Displacement cm ³ / n	Pressure Range bar		
10	PR 10.10	6,30	500	550	4 - 40	280 - 170	1500	700 - 1800
	PR 10.12	8,90	350	390				
	PR 10.13	10,60	300	340				
	PR 10.14	12,30	250	280				
14	PR 14.10	8,82	500	550				
	PR 14.12	12,70	350	390				
	PR 14.13	14,80	300	340				
	PR 14.14	17,20	250	280				

(*) For good performances, the minimum speed of the gear pump should not be less than 700 n/min.

Always make sure that the torque applied is less than or equal to the admissible torque of the shaft.

MULTIPLE PUMP PR 10 - 14 + Gear Pump Gr 2 - INSTALLATION DRAWING

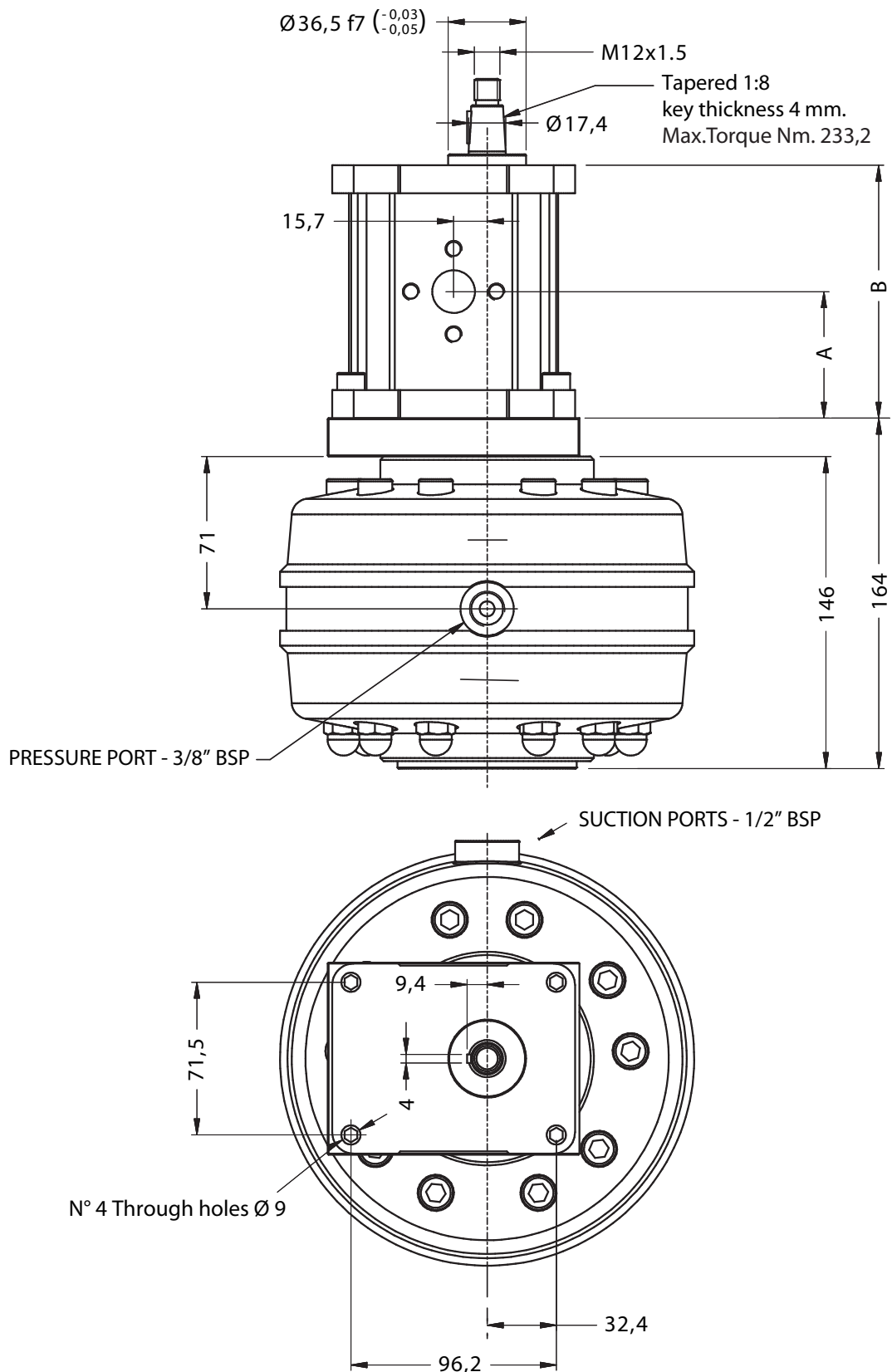

Always make sure that the torque applied is less than or equal to the admissible torque of the shaft.

MULTIPLE PUMP PR 10 - 14 + Gear Pump Gr 3 - TECHNICAL SPECIFICATION

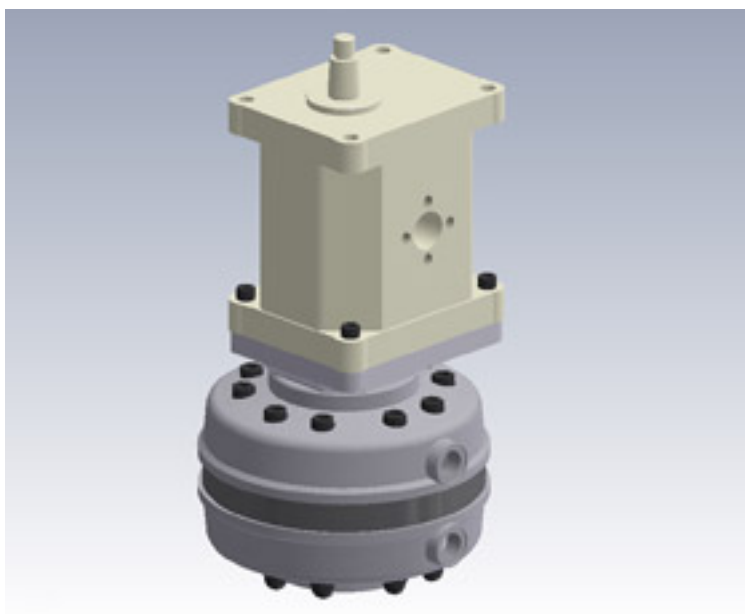

N° of Pistons	Pump Type	Piston Pump			Gear Pump Gr 3		Rated Speed n/min.	Speed Range n/min. (*)
		Displacement cm ³ / n	Rated Pressure bar	Peak Pressure bar	Displacement cm ³ / n	Pressure Range bar		
10	PR 10.10	6,30	500	550	22 - 90	270 - 180	1500	700 - 1800
	PR 10.12	8,90	350	390				
	PR 10.13	10,60	300	340				
	PR 10.14	12,30	250	280				
14	PR 14.10	8,82	500	550	22 - 90	270 - 180	1500	700 - 1800
	PR 14.12	12,70	350	390				
	PR 14.13	14,80	300	340				
	PR 14.14	17,20	250	280				

(*) For good performances, the minimum speed of the gear pump should not be less than 700 n/min.

Always make sure that the torque applied is less than or equal to the admissible torque of the shaft.

MULTIPLE PUMP PR 10 - 14 + Gear Pump Gr 3 - INSTALLATION DRAWING

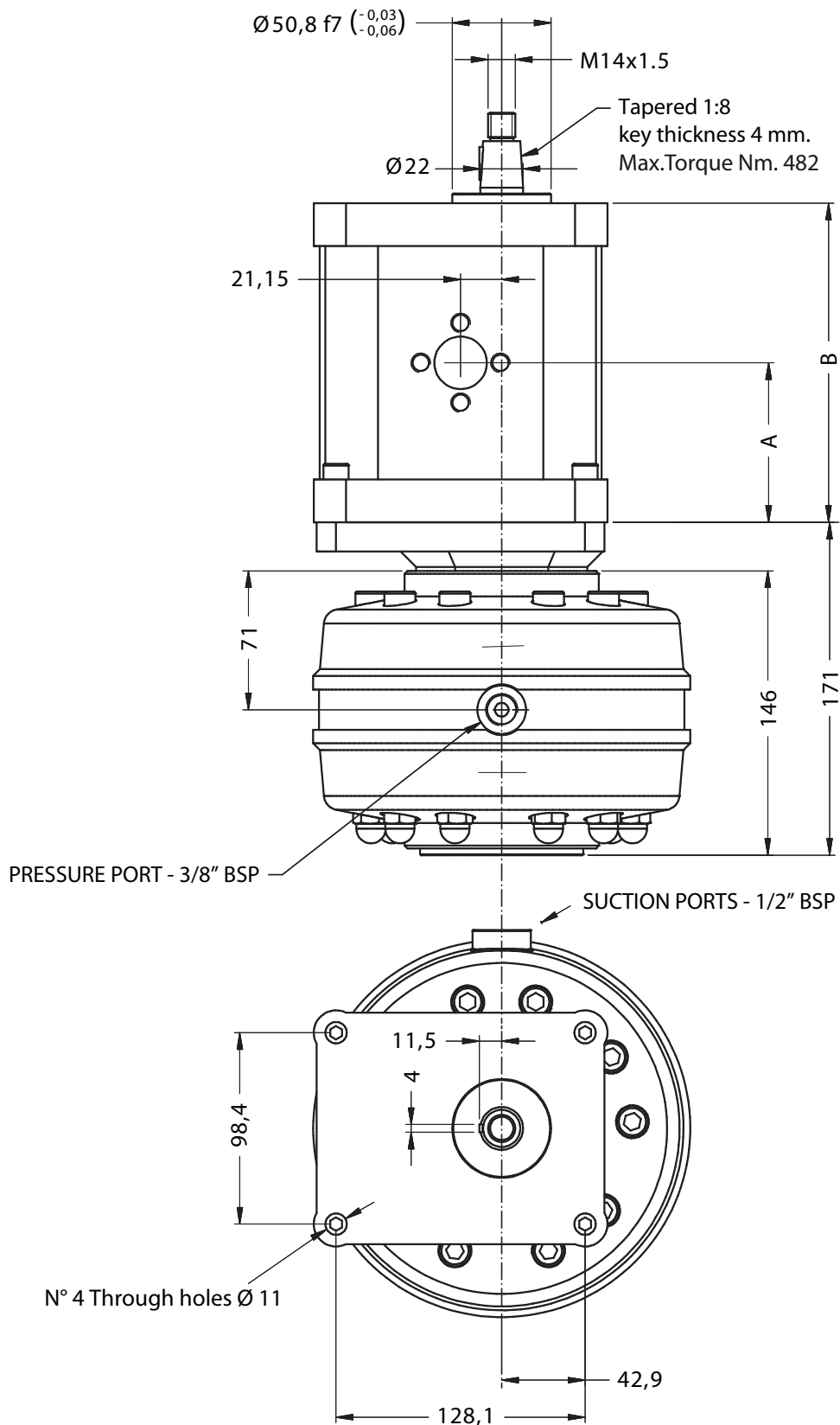

Always make sure that the torque applied is less than or equal to the admissible torque of the shaft.

TECHNICAL INFORMATION

INSTALLATION

PR pumps are suitable for oil-submersed or external mounting and must be installed in proper position their feeding. When installed outside the tank, these pumps should be positioned below the minimum fluid level as this ensures that a sufficient amount of fluid can flow in automatically via a steadily downwards feed line.

This is valid even for eventual external filter in the suction line, which internal diameter must not be less than 15 mm. For head more than 3 meters, ask for the pump with special shaft seal.

In submersed installations, they must be used only with no piston caps and with the orifices of suction under the minimal level of the oil during the functioning.

The figure below indicates the most correct installation positions:

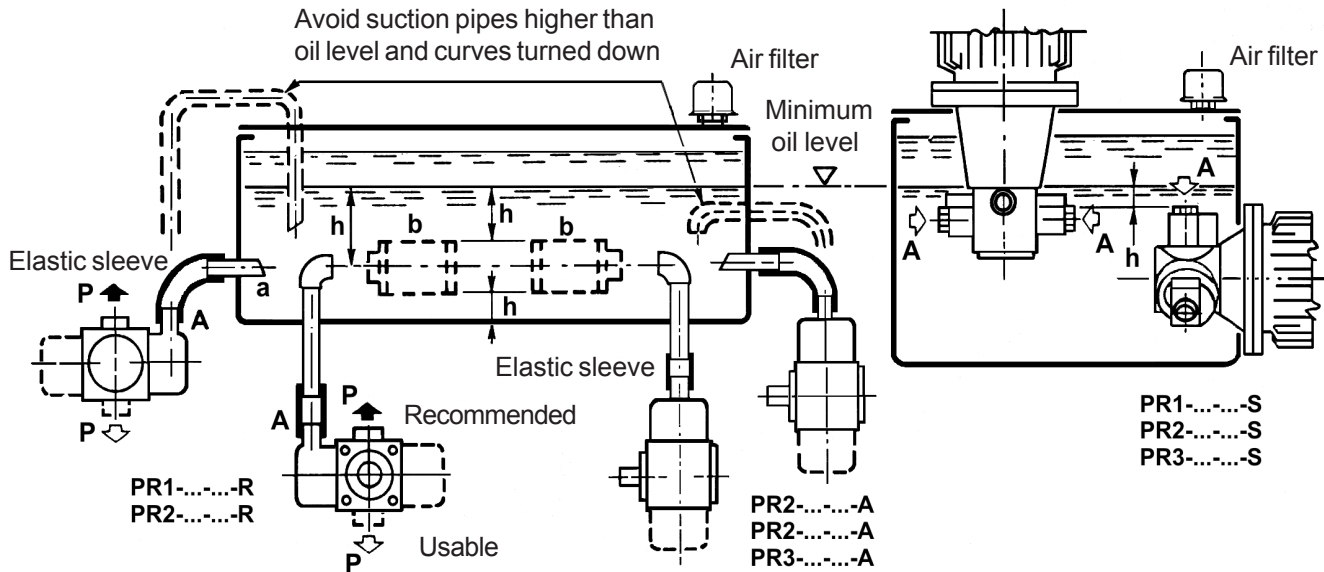

External Installation

- a) Suction pipe internal diameter not less than 15 mm.
- b) Suction filter, see filtering paragraph.
- h) Distance of suction elements to minimum oil level and tank bottom not less than 50 mm.

Oil-submersed Installation

STARTING AND USE PRECAUTION

Fill with oil and air well purged, the pump gets into action with impulses, first without putting it under pressure. Excessive rumours and/or irregular pulsations indicate an incomplete primer: insist with the impulses rotation and pressurizing step by step.

Rarely there would be the need of filling the little cylinders through the orifices of the little suction valves.

- In the first hours of work check the filter many times, above all if it is positioned on the suction.
- When cold started, begin the exercise only after several minutes of running at regular pressure.
- Specially if used with heavy or continuous service, we advise to:
 - 1 - Check monthly the cleaning of oil and air filters, the grade of ageing and pollution of the fluid, and its level;
 - 2 - Replace oil after about 2000 hours of service or once or twice a year, previous cleaning of the tank;
 - 3 - Periodically check that, during operation, the oil temperature does not exceed the 60-70°C.

FILTERING

We advise a filtration of 40 micron, otherwise:

- for discontinuous and/or less heavy operation: 90-60 micron
- for continue and/or heavy operation: 60- 25 micron

Exceptionally it is possible to use a suction filter, which can not be applied for the pumps with no piston caps. Limit the use of these filters to the plants with discontinue and/or light service, checking them frequently.

Install an air filter on the tank, proportioned to the grade of environmental pollution.

ORDER CODE

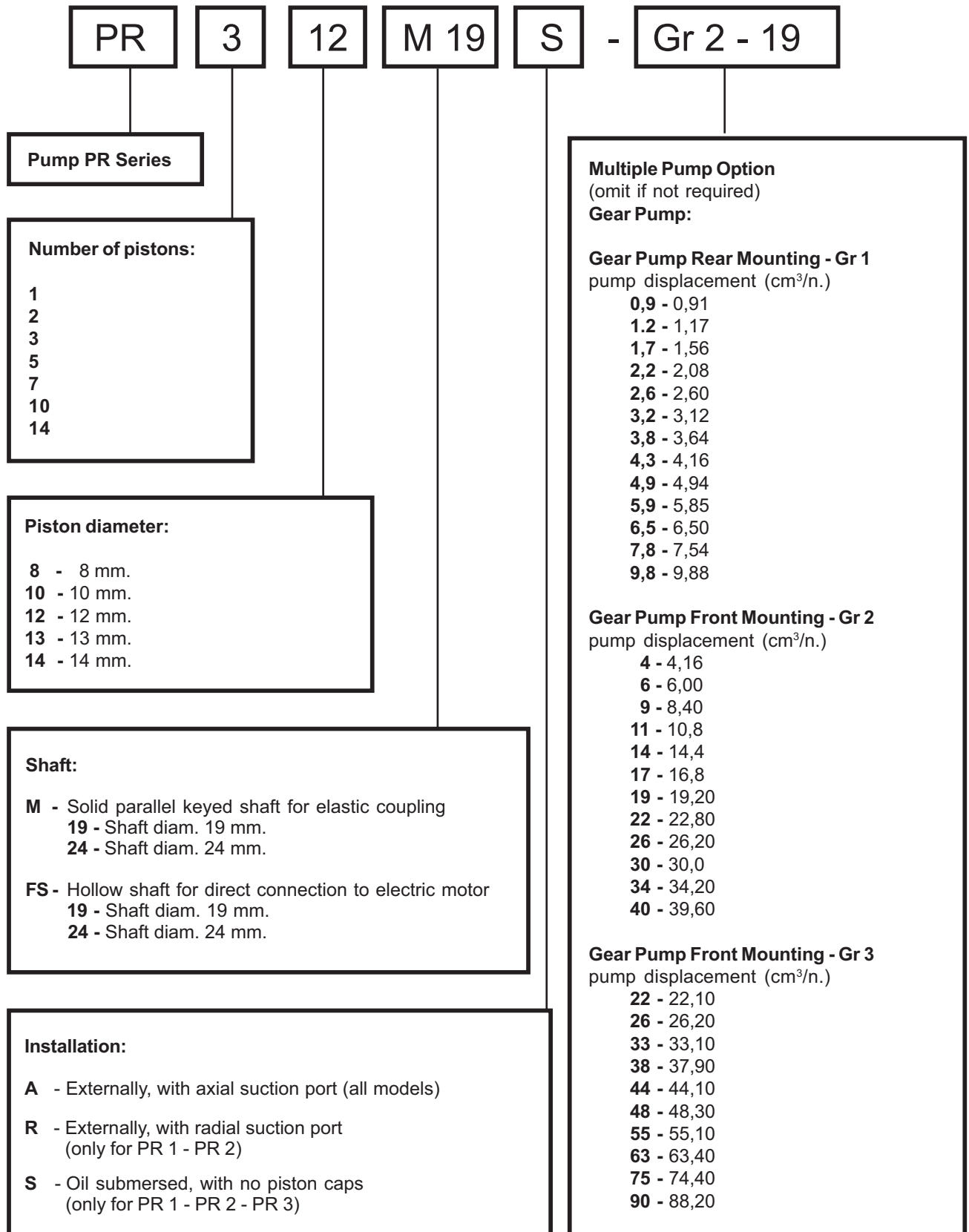

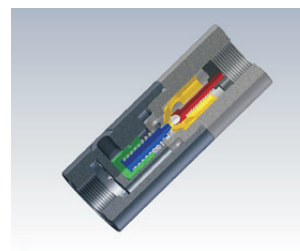
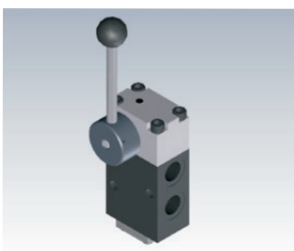
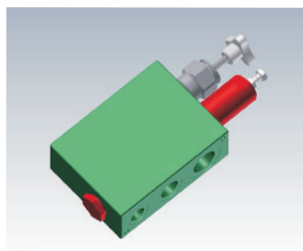
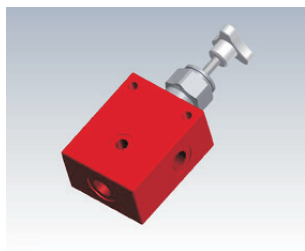
VALVES - GENERAL INFORMATION

HANSA-TMP can offer an extensive range of valves suitable to be used in combination with high-pressure radial piston pumps:

- VM-series relief valves, high-low-pressure exclusion valves VEM-series
- Directional control valves for 450 Bar, up to 100 l/min.
- Check valves and pilot check-valves (up to 400 bar working pressure)
- Others on request

PESSURE RELIEF VALVE VM 6 - GENERAL INFORMATION

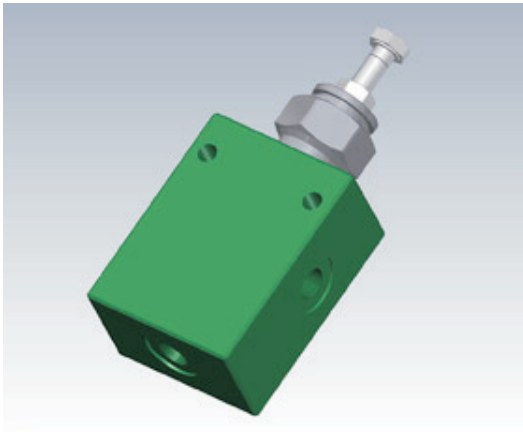

Technical data:

the Pressure Relief Valve VM-6 is designed and assembled into a block with threaded ports for in-line installation.

This version uses a carbon steel manifold with anticorrosive treatment of the surface and having 1/4" BSP ports.

The VM-6 valve is available with screw setting mechanism (C) or with handwheel setting mechanism (V).

- Valve Nominal Size - DN6
- Rated Flow - max. 25 lt/min.
- Rated Pressure (available springs)
 - up to 50 bar
 - up to 100 bar
 - up to 200 bar
 - up to 300 bar
 - up to 450 bar

INSTALLATION DRAWING

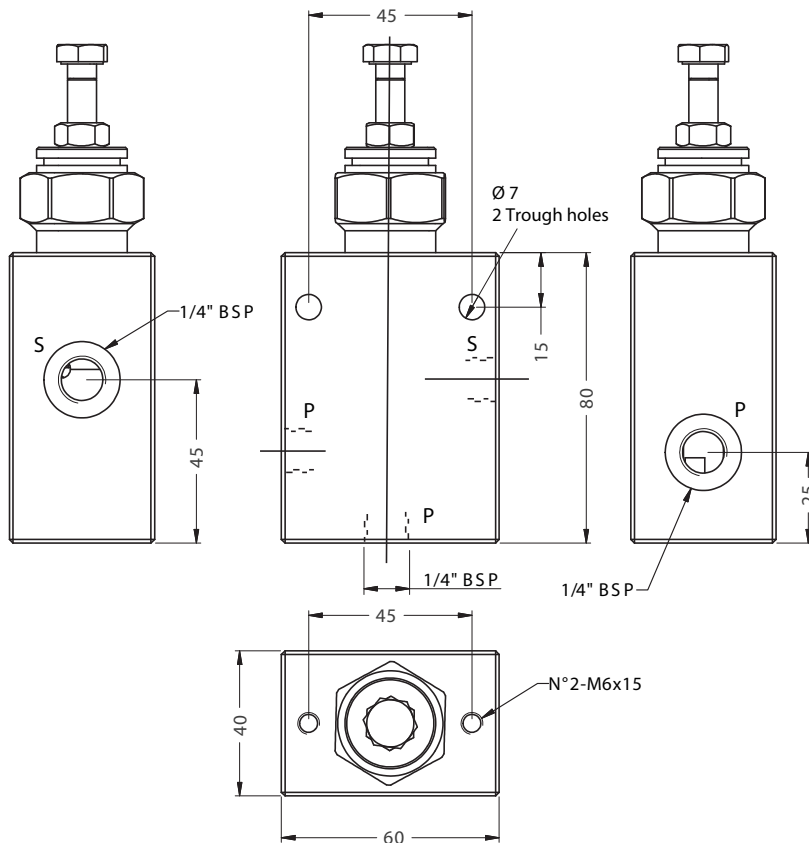

P - Pressure port
S - Tank port

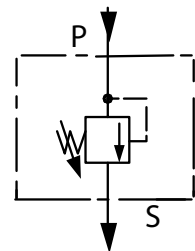

ORDER CODE

VM 6 - 300 - C

Valve model **VM 6**
Pressure adjustment range:
50 = up to 50 bar
100 = up to 100 bar
200 = up to 200 bar
300 = up to 300 bar
450 = up to 450 bar

Setting mechanism: **C** = Screw
V = Handwheel

PESSURE RELIEF VALVE VM 8 - GENERAL INFORMATION



Technical data:

the Pressure Relief Valve VM-8 is designed and assembled into a block with threaded ports for in-line installation.

This version uses a carbon steel manifold with anticorrosive treatment of the surface and having 3/8" BSP ports.

The VM-8 valve is available with screw setting mechanism (C) or with handwheel setting mechanism (V).

- Valve Nominal Size - DN8
- Rated Flow - max. 40 lt/min.
- Rated Pressure (available springs)
 - up to 50 bar
 - up to 100 bar
 - up to 200 bar
 - up to 300 bar
 - up to 450 bar

INSTALLATION DRAWING

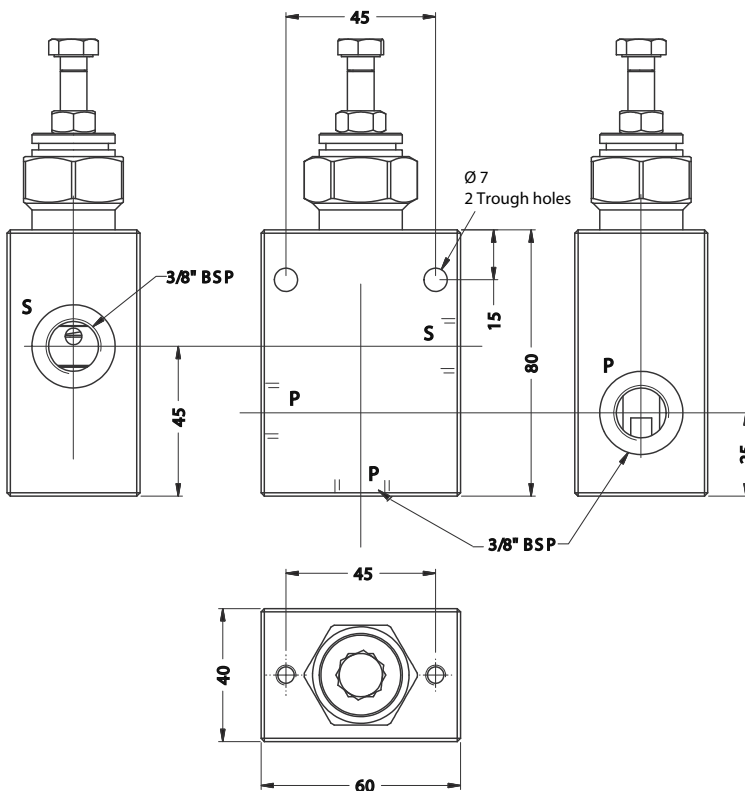

P - Pressure port
S - Tank port

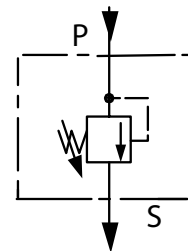

ORDER CODE

VM 8 - 300 - C

Valve model **VM8**
Pressure adjustment range:
50 = up to 50 bar
100 = up to 100 bar
200 = up to 200 bar
300 = up to 300 bar
450 = up to 450 bar

Setting mechanism: **C** = Screw
V = Handwheel

PESSURE RELIEF VALVE VM 10 - GENERAL INFORMATION

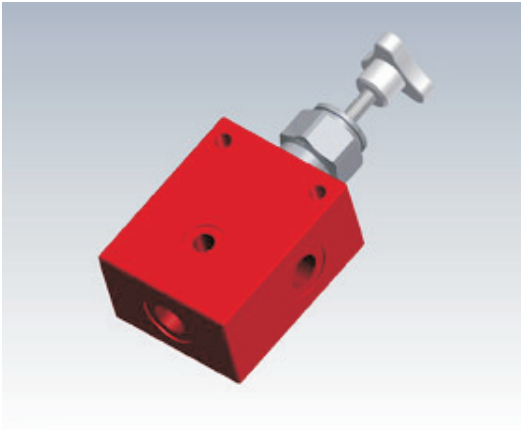

Technical data:

the Pressure Relief Valve VM-10 is designed and assembled into a block with threaded ports for in-line installation.

This version uses a carbon steel manifold with anticorrosive treatment of the surface and having 1/2" BSP ports.

The VM-10 valve is available with screw setting mechanism (C) or with handwheel setting mechanism (V).

- Valve Nominal Size - DN10
- Rated Flow - max. 50 lt/min.
- Rated Pressure (available springs)
 - up to 50 bar
 - up to 100 bar
 - up to 200 bar
 - up to 300 bar
 - up to 420 bar

INSTALLATION DRAWING

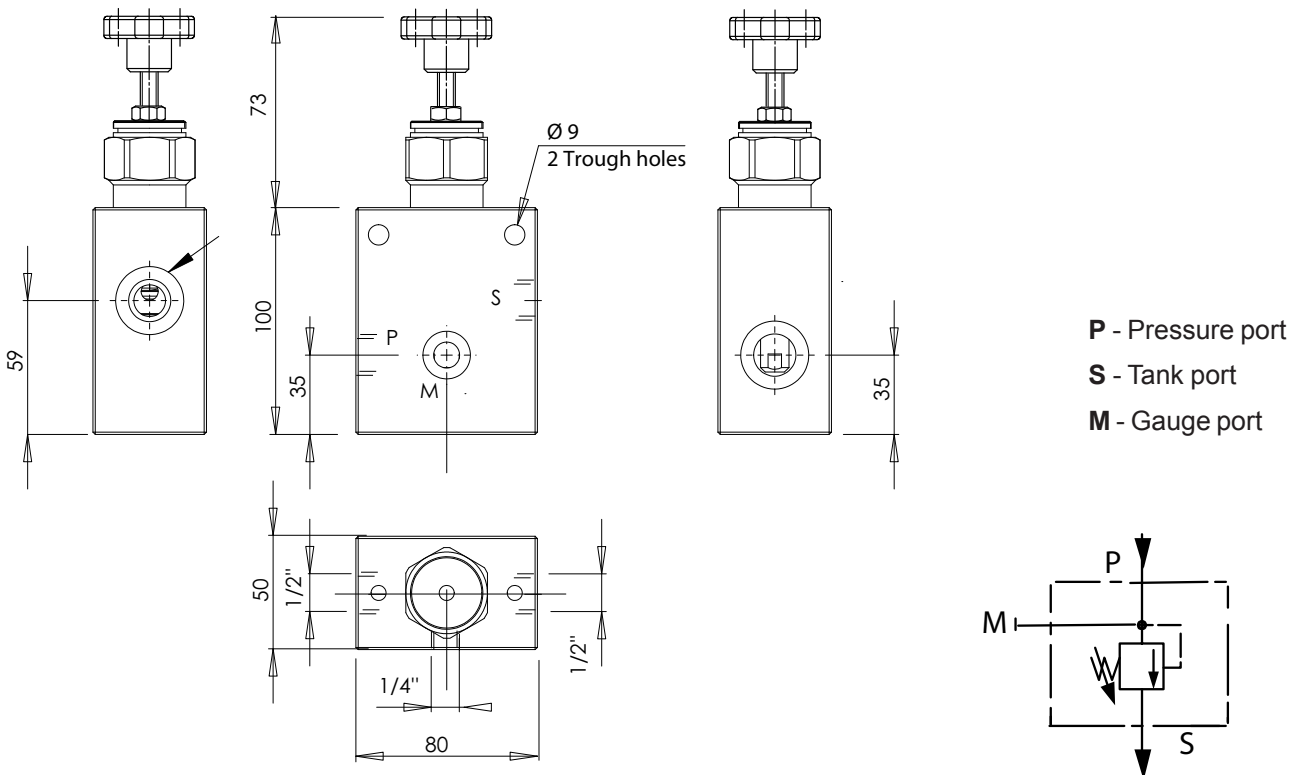

ORDER CODE

VM 10 - 300 - C

Valve model **VM 10**
 Pressure adjustment range:
50 = up to 50 bar
100 = up to 100 bar
200 = up to 200 bar
300 = up to 300 bar
420 = up to 420 bar

Setting mechanism: **C** = Screw
V = Handwheel

EXCLUSION VALVE VEM 13 - GENERAL INFORMATION



Technical data:

the VEM valve is a high-low-pressure exclusion valve to be used in combination with tandem pumps, where a low-pressure gear pump supplies high flow, and when the set low pressure is reached, the high flow is discharged to tank, while the high pressure / low-flow radial piston pump is increasing the system pressure up to the maximum set pressure.

The application is common in hydraulic presses.

Rated Flow: High Press. 10 lt/min. - Low press. 40 lt/min.

High Pressure Range (available springs)

- up to 50 bar
- up to 100 bar
- up to 200 bar
- up to 300 bar
- up to 450 bar

INSTALLATION DRAWING

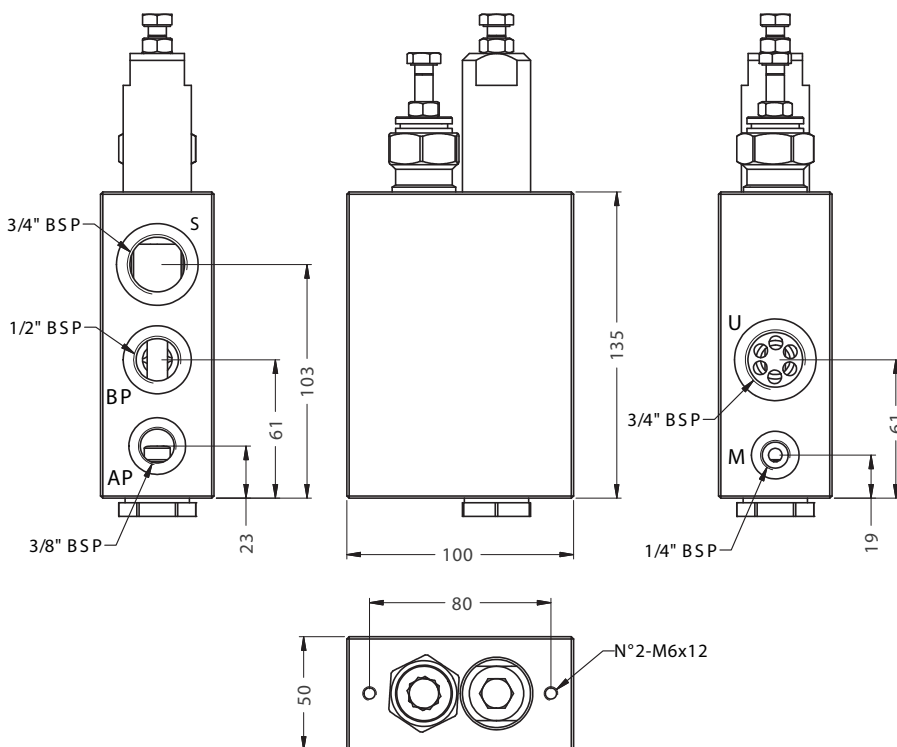

- AP** - High Pressure port
- BP** - Low Pressure port
- S** - Tank port
- U** - Outlet port
- M** - Gauge port

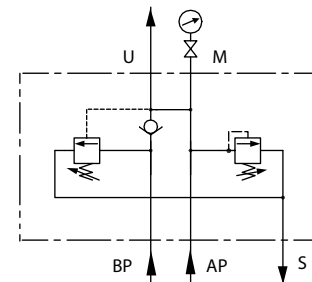

ORDER CODE

VEM 13 - 300 - C

Valve model **VEM 13**
High Pressure adjustment range:

- 50** = up to 50 bar
- 100** = up to 100 bar
- 200** = up to 200 bar
- 300** = up to 300 bar
- 450** = up to 450 bar

AP-Setting mechanism: **C** = Screw

V = Handwheel

EXCLUSION VALVE VEM 16 - GENERAL INFORMATION

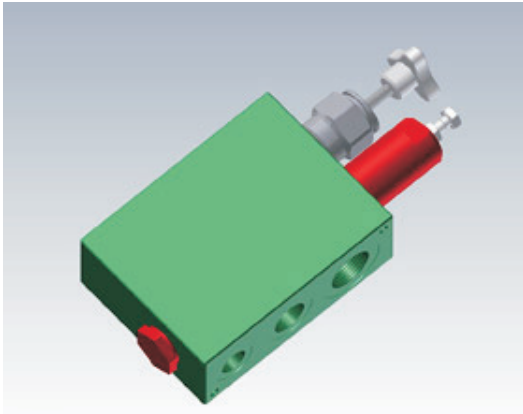

Technical data:

the VEM valve is a high-low-pressure exclusion valve to be used in combination with tandem pumps, where a low-pressure gear pump supplies high flow, and when the set low pressure is reached, the high flow is discharged to tank, while the high pressure / low-flow radial piston pump is increasing the system pressure up to the maximum set pressure.

The application is common in hydraulic presses.

Rated Flow: High Press. 20 lt/min. - Low press. 80 lt/min.

High Pressure Range (available springs)

- up to 50 bar
- up to 100 bar
- up to 200 bar
- up to 300 bar
- up to 420 bar

INSTALLATION DRAWING

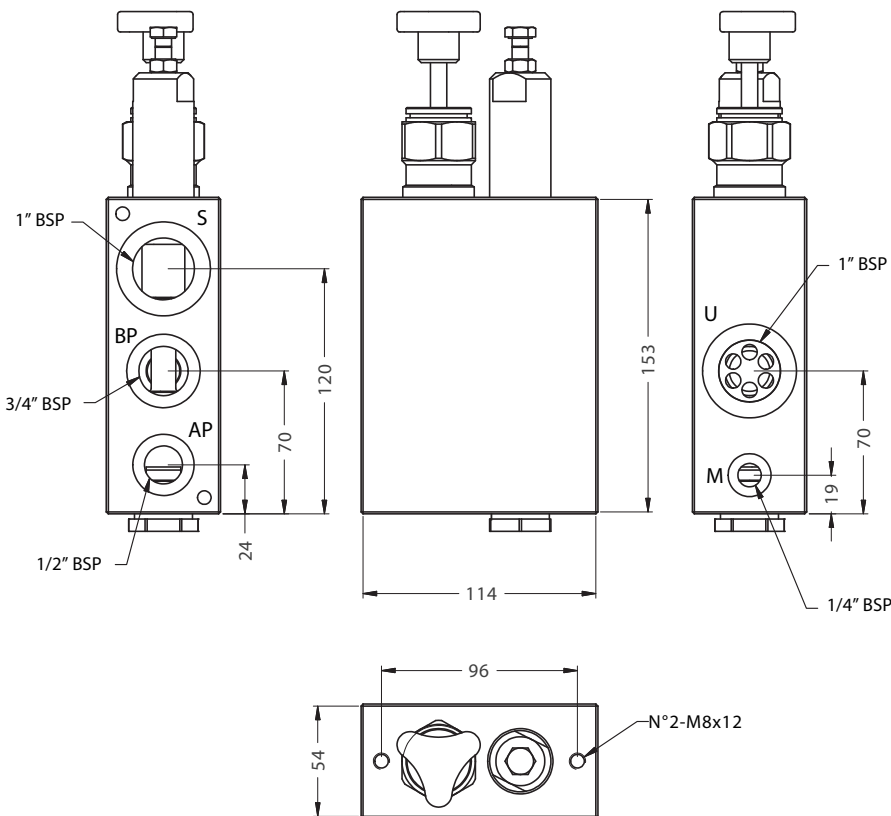

- AP** - High Pressure port
- BP** - Low Pressure port
- S** - Tank port
- U** - Outlet port
- M** - Gauge port

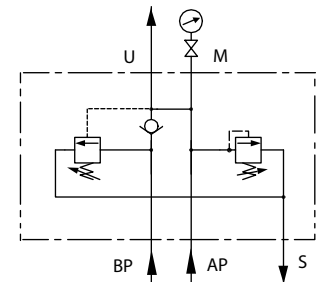

ORDER CODE

VEM 16 - 300 - C

Valve model **VEM 16**
 High Pressure adjustment range:
50 = up to 50 bar
100 = up to 100 bar
200 = up to 200 bar
300 = up to 300 bar
420 = up to 420 bar

AP-Setting mechanism: **C** = Screw
V = Handwheel

HIGH PRESSURE DIRECTIONAL CONTROL VALVE - GENERAL INFORMATION

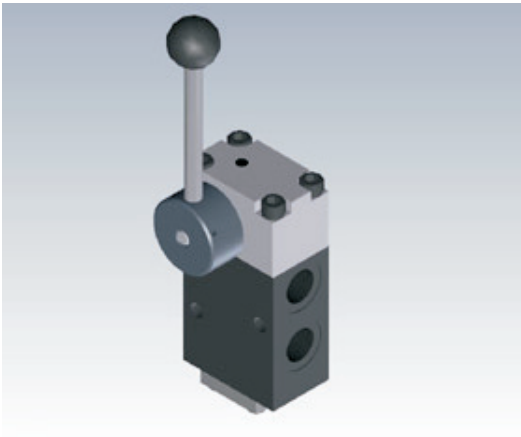

Technical data:

manually operated directional control valves series 4L are specifically built for use with high pressure.

The distribution system is of balanced spool type, in this way the operating force is not influenced by the pressure value.

Distributors are available with spring for free return to central position or with detents to hold the lever in the desired position.

Two schemes are available of internal connection between the oil ports, thus different system requirements can be satisfied.

The discharge port S can bear the maximum pressure allowing the connection in series of more distributors.

TECHNICAL SPECIFICATIONS

4L-15F with ports 3/4" BSP, flow capacity up to 60 lt/min.

4L-20F with ports 1" BSP, flow capacity up to 100 lt/min.

Pressure up to 450 bar

Circuits:

CC - Closed

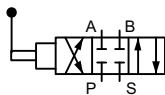

PS - Pressure on tank

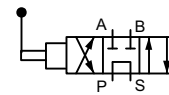

ORDER CODE

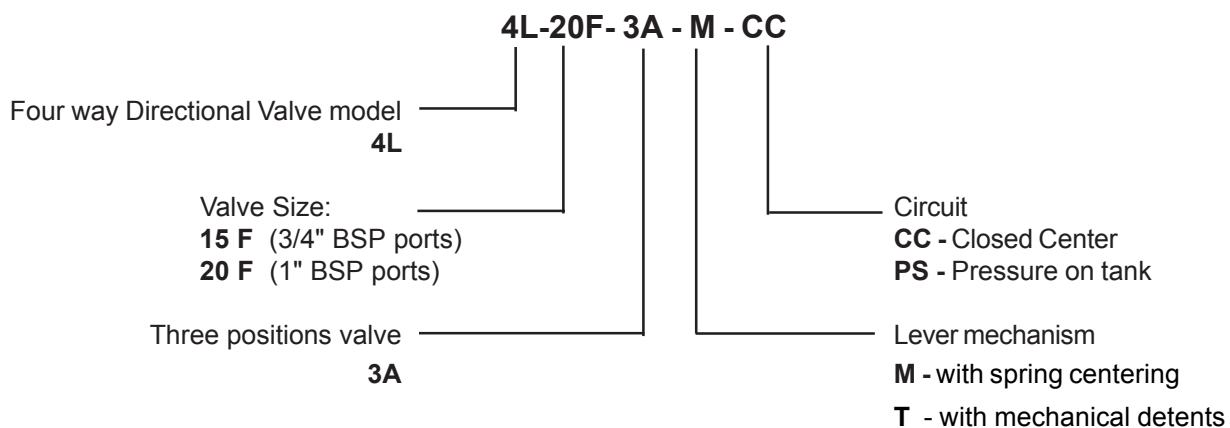

**HIGH PRESSURE DIRECTIONAL CONTROL VALVE 4L-15F-3AT/M
INSTALLATION DRAWING**

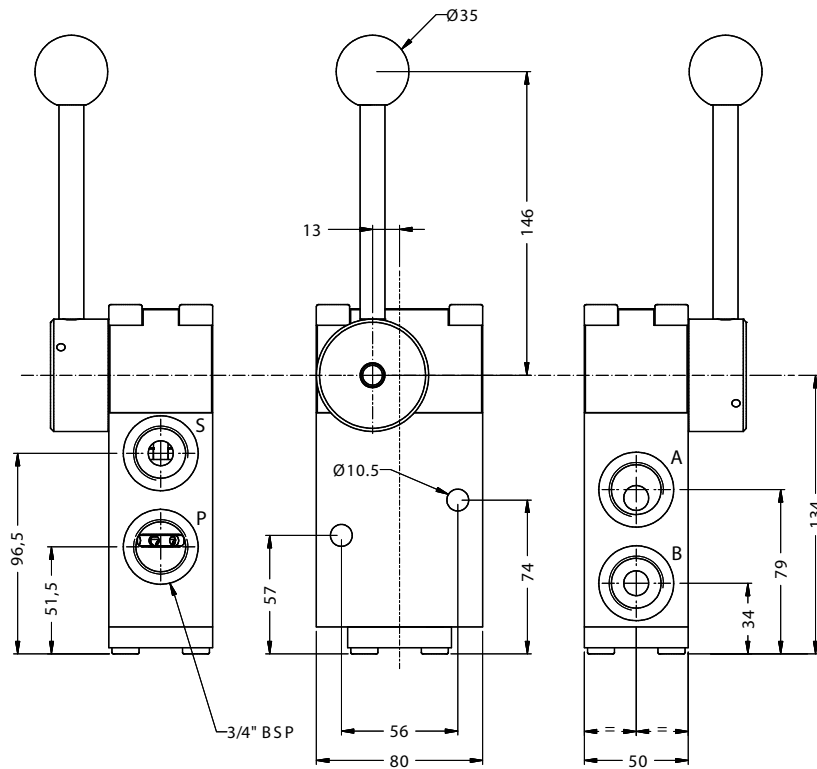

**HIGH PRESSURE DIRECTIONAL CONTROL VALVE 4L-20F-3AT/M
INSTALLATION DRAWING**

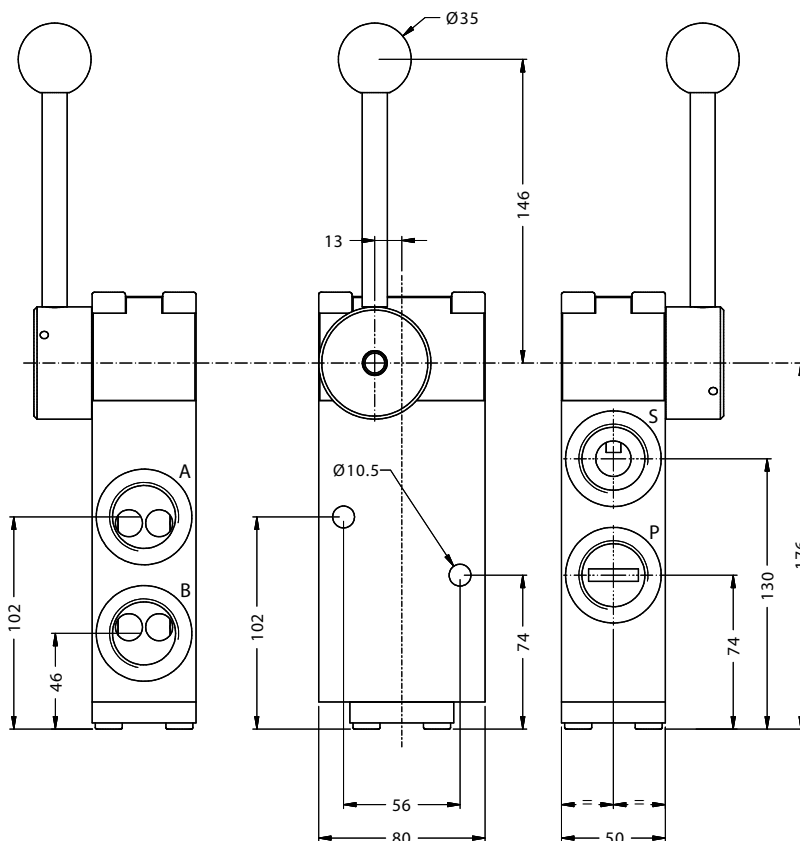

IN-LINE PILOT OPERATED CHECK VALVE WITH DECOMPRESSION DEVICE DCZ SERIES

GENERAL INFORMATION

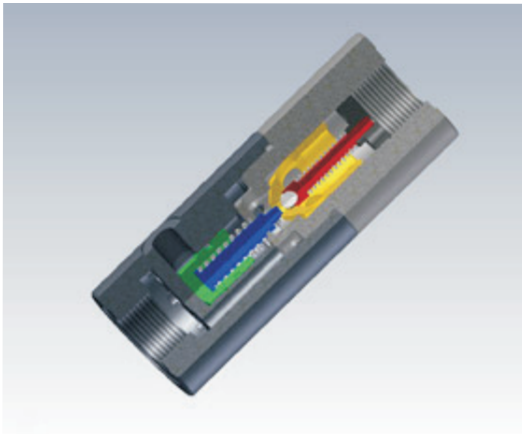

Technical data:

the Pilot operated check valves allow free oil flow in one direction, while in opposite direction it is blocked, unless a pilot pressure is applied for opening.

These valves are suitable to maintain a system pressurized also during long time, while the pumps are not working. To avoid heavy shocks during pilot opening, there is an initial decompression before full opening of the valve.

Recommended for system pressure up to 400 bar.

The DCZ-series valves are available in 3 sizes, suitable for max. flow 70, 110 and 170 l/min.

TECHNICAL SPECIFICATIONS - INSTALLATION DRAWING

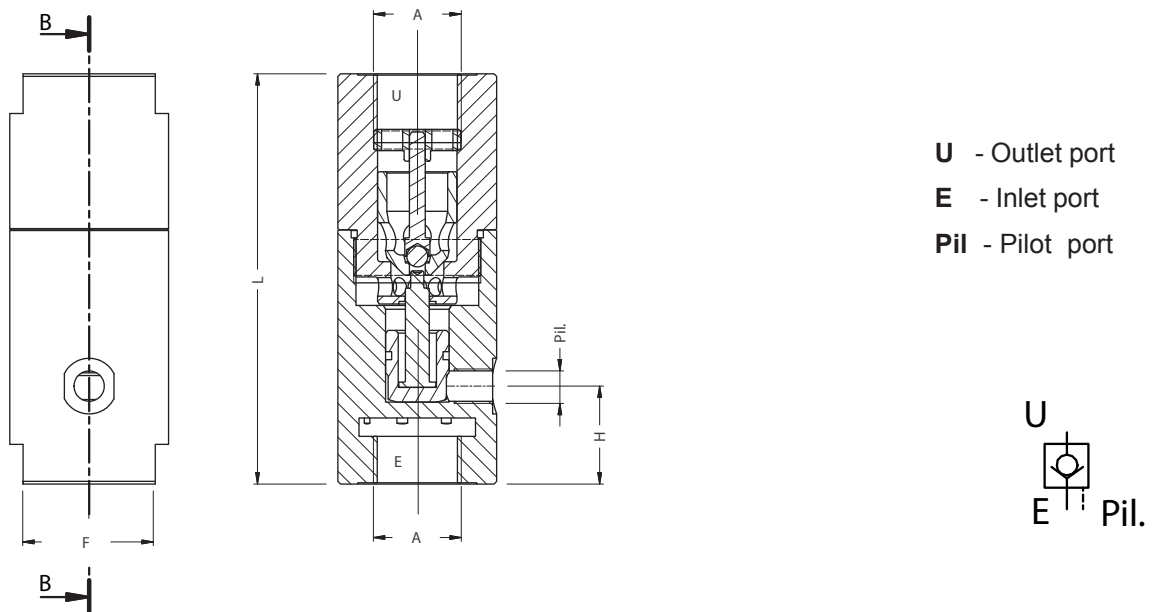

VALVE TYPE	Max. Flow lt/min.	Max. Pressure bar	Decompression Pilot Ratio 1:	Opening Pilot Ratio 1:	Dimensions				
					A	Pil.	L	F	H
DCZ- 15F	70	400	16	1,4	1/2" BSP	1/4" BSP	135	52	32
DCZ- 20F	110		16	1,4	3/4" BSP	1/4" BSP	155	60	32
DCZ- 25F	170		18	1,4	1" BSP	1/4" BSP	185	70	32

ORDER CODE

DCZ- 15F

Valve model ———— | ———— Valve size:

15F (1/2" BSP ports)
20F (3/4" BSP ports)
25F (1" BSP ports)

As HANSA-TMP has a very extensive range of products and some products have a variety of applications, the information supplied may often only apply to specific situations.

If the catalogue does not supply all the information required, please contact HANSA-TMP.

In order to provide a comprehensive reply to queries we may require specific data regarding the proposed application.

Whilst every reasonable endeavour has been made to ensure accuracy, this publication cannot be considered to represent part of any contract, whether expressed or implied.

HANSA-TMP reserves the right to amend specifications at their discretion.



HYDRAULIC COMPONENTS
HYDROSTATIC TRANSMISSIONS
GEARBOXES - ACCESSORIES

Via M. L. King, 6 - **41122 MODENA (ITALY)**
Tel: +39 059 415 711
Fax: +39 059 415 729 / 059 415 730
INTERNET: <http://www.hansatmp.it>
E-MAIL: hansatmp@hansatmp.it