

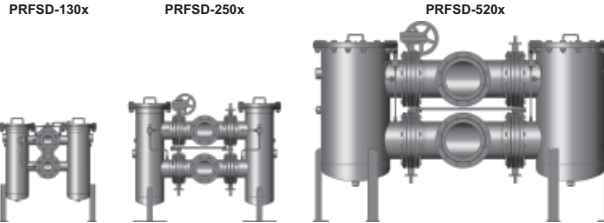

Process Screen Basket Filter, Change-Over Version PRFSD



1. TECHNICAL SPECIFICATIONS

1.1 GENERAL

Screen basket filters are used mainly as coarse filters or pre-filters. The direction of flow is from the inside to the outside. The separated solid contamination is collected in the stainless steel screen basket and can be disposed of quickly and conveniently. By using clogging indicators which monitor the differential pressure, the condition of the screen basket filter can be determined at any time. The filter materials can be cleaned and reused, and this therefore reduces operating costs. Filter housings are available in carbon steel with an internal epoxy coating and in stainless steel.

1.2 SUMMARY OF AVAILABLE SIZES AND CONNECTIONS

Connection size	Series				
	130x	250x	520x	650x	1500x
DN 50	●				
DN 80	●				
DN 100	●	●			
DN 150		●	●		
DN 200		●	●	●	
DN 250			●	●	●
DN 300				●	●

The selection of the connection size depends on the level of contamination of the fluid and the associated filter area.

1.3 CIRCUIT DIAGRAM

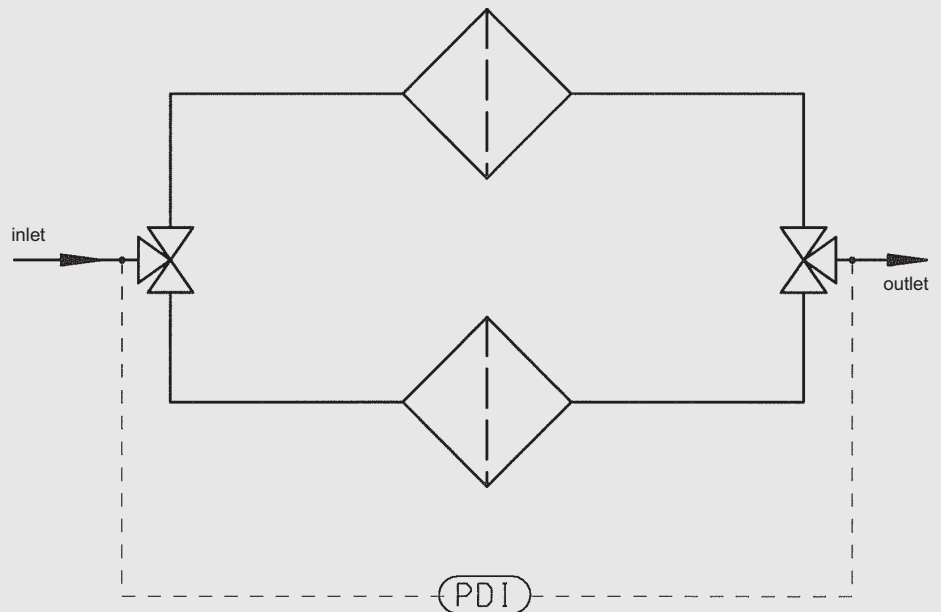

2. FILTER SPECIFICATIONS

2.1 SUMMARY OF TECHNICAL SPECIFICATIONS OF STANDARD FILTER HOUSINGS

Series	Type	Connection size DIN DN	Materials			Pressure range*	Temperature [°C]	Weight [kg]	Volume [l]
			Stainless steel	Carbon steel					
				without int. corrosion protection	with int. corrosion protection				
130x	1303	50/	●			PN 16	-10 to 90	80	20
	1304	80/			●				
	1305	100		●					
250x	2503	100/	●					130	46
	2504	150/			●				
	2505	200		●					
520x	5203	150/	●					300	118
	5204	200/			●				
	5205	250		●					
650x	6503	200/	●					360	213
	6504	250/			●				
	6505	300		●					
1500x	15003	300	●			460	433		
	15004				●				
	15005			●					

* Other pressure ranges for welded versions on request.

2.2 FURTHER SPECIFICATIONS OF THE STANDARD FILTER HOUSING

2.2.1 Seal materials

FPM (Viton), asbestos-free gasket

2.2.2 Corrosion protection, external

2-coat primer (not required for stainless steel filters)

2.2.3 Corrosion protection, internal

2K epoxy coating (not required for stainless steel filters)

2.2.4 Documentation

Operating and maintenance instructions

2.3 SUMMARY OF TECHNICAL SPECIFICATIONS OF FILTER ELEMENTS

Series	No. of screen baskets / housing	Filter area / housing [cm²]	Filter element type	Filter materials and filtration ratings [µm]		Permiss. Diff. pressure across element [bar]
				Slotted tube	Perforated plate	
130x	1	2035	SK-3-...	50, 100, 200, 250, 300, 500, 1000, 2000, 3000	4000, 5000, 10000	10
250x	1	2850	SK-4-...			
520x	3	6105	SK-3-...			
650x	4	11400	SK-4-...			
1500x	7	19950	SK-4-...			

2.4 OPTIONAL VERSIONS

There is a range of optional versions available for the Process Screen Basket Filter PRFSD. For technical details and prices, please contact our Technical Sales Department at Head Office.

2.4.1 Housing manufacture

- AD Notices / PED 97/23/EC
- ASME Code Design (with or without U-Stamp)

2.4.2 Flange connections

- ANSI
- JIS

2.4.3 Housing materials

- Various qualities of stainless steel
- Various qualities of carbon steel

2.4.4 Materials of internal parts and elements

- Various qualities of stainless steel
- Various qualities of carbon steel
- Various qualities of Duplex/ Superduplex

2.4.5 Cover plate lifting devices

- Stainless steel version
- Carbon steel version

2.4.6 Seal materials

- Various seal materials on request, depending on the resistance to the fluid

2.4.7 Corrosion protection and external finishes

- RAL colours according to customer requirement (on carbon steel qualities)
- Various multi-layer coatings

2.4.8 Differential pressure monitoring

- Visual
- Electrical
- Visual-electrical
- Differential pressure gauge with 2 microswitches

2.4.9 Documentation

- Manufacturer's test certificates
- Material certificates 3.1 according to DIN EN 10204
- 3rd parties (TÜV, ABS, Lloyds, etc)
- Welding procedure specifications (WPS) / Procedure Qualification Record (PQR)
- Inspection plan
- and many others on request

Further optional models on request

3. MODEL CODE

PRFSD - S - 1303 - AF3 - 10 - 0 - 1 - X

3.1 SCREEN BASKET FILTER PRFS / PRFSD

Type

PRFS = Screen basket filter
PRFSD = Screen basket filter duplex (change-over)

Material of filter element

D = wire mesh (cleanable)
S = slotted tube (cleanable)
L = perforated plate (cleanable)

Size

130x = DN 50 / 80 / 100
250x = DN 100 / 150 / 200
520x = DN 150 / 200 / 250
650x = DN 200 / 250 / 300
1500x = DN 250 / 300 / 400
2500x = DN 500 / 600 / 700 (only for single filter PRFS)

End code x

x = 3 stainless steel housing
x = 4 housing carbon steel + epoxy internal coating
x = 5 housing carbon steel without coating

Type of connection (see table)

F = flange to DIN followed by nominal width e.g. F100
AF = flange to ANSI followed by nominal width in inches

Filtration rating in μm

50, 100, 200, 300, 500, 1000, 2000, 3000 (slotted tube)
3000, 4000, 5000, 10000 (perforated plate)

Equipment

0 = without additional equipment
1 = cover plate lifting device
2 = vent and drain ball valve

Type of clogging indicator

0 = without clogging indicator
1 = visual indicator PVD 2 B.1
2 = visual-electrical indicator PVD 2 D.0
3 = visual-electrical-analogue indicator V01
4 = visual-analogue indicator in aluminium with 2 adjustable contacts (0...4 bar)
5 = visual-analogue indicator in stainless steel with 2 adjustable contacts (0...4 bar)
6 = electrical differential pressure switch PVD 2 C.0

Modification number

X = the latest version is always supplied

Supplementary details

Drawing number for special equipment

3.2 SCREEN BASKET ELEMENT

SK - 4 - S - 1000 - 0

Element construction

Screen basket element with handle

Size

1, 2, 3, 4, 5

Material of filter element

S = slotted tube
L = perforated plate

Filtration rating in μm

50, 100, 200, 300, 500, 1000, 2000, 3000 (slotted tube)
3000, 4000, 5000, 10000 (perforated plate)

Seal material

0 = no seal for filtration rating > 500
V = Viton
N = NBR
EP = EPDM
SI = Silicon

4. FILTER CALCULATION / SIZING

4.1 PRESSURE DROP CURVES FOR HOUSING

The curves apply to water at 20°C

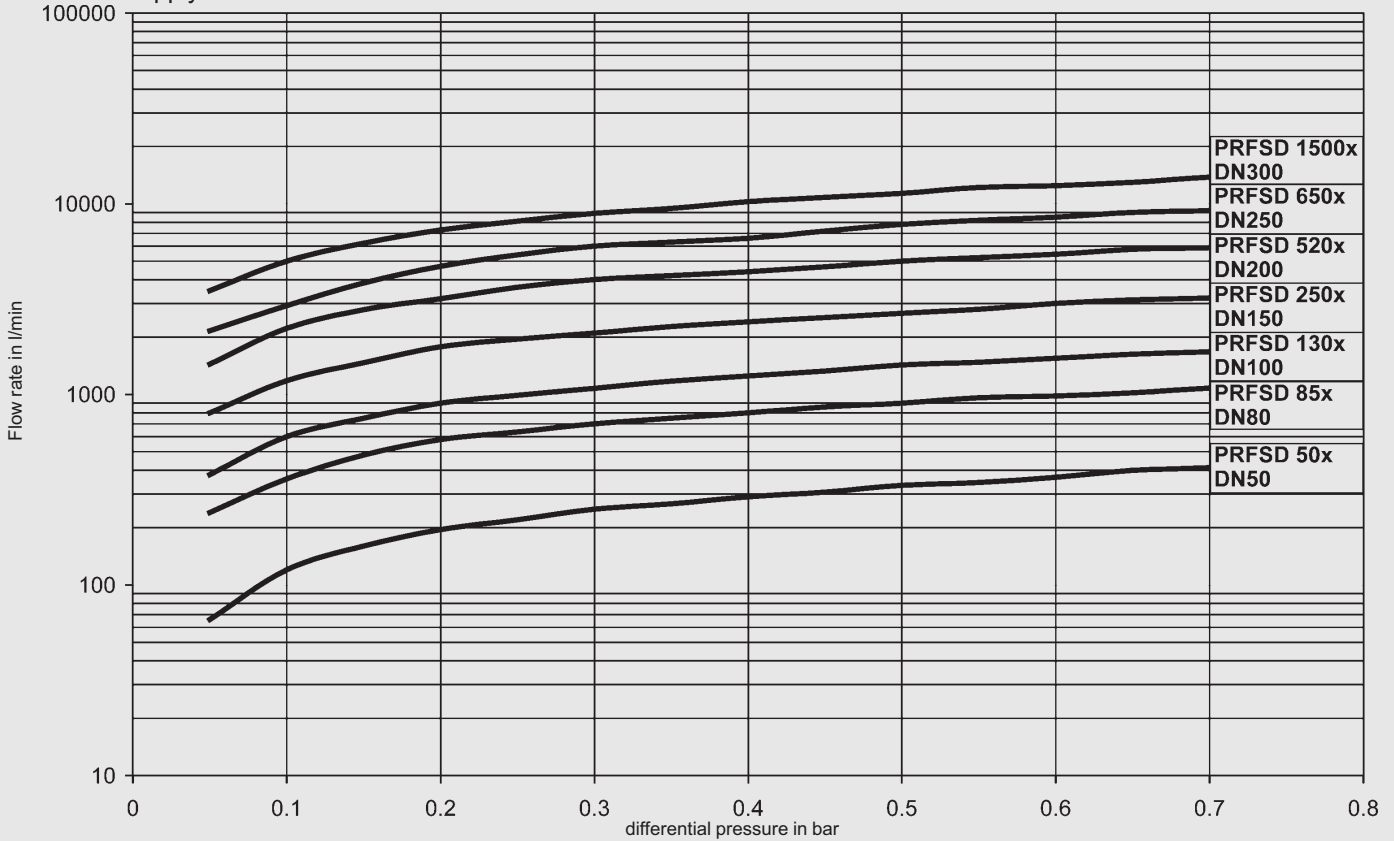

4.2 CALCULATION CRITERIA

In order to be able to size the filter correctly, the following design data should be available:

- Flow rate
- Type of medium
- Materials / resistance
- Viscosity
- Required filtration rating
- Particulate loading in the fluid
- Type of contamination
- Operating pressure
- Operating temperature

Use the pressure drop curves to calculate the Process Inline Filters PRFS and PRFSD.

A further factor in the calculation is the flow velocity through the flange inlet. It should not exceed 4 m/s.

5. DIMENSIONS

5.1 FILTER HOUSING

PRFSD 130x

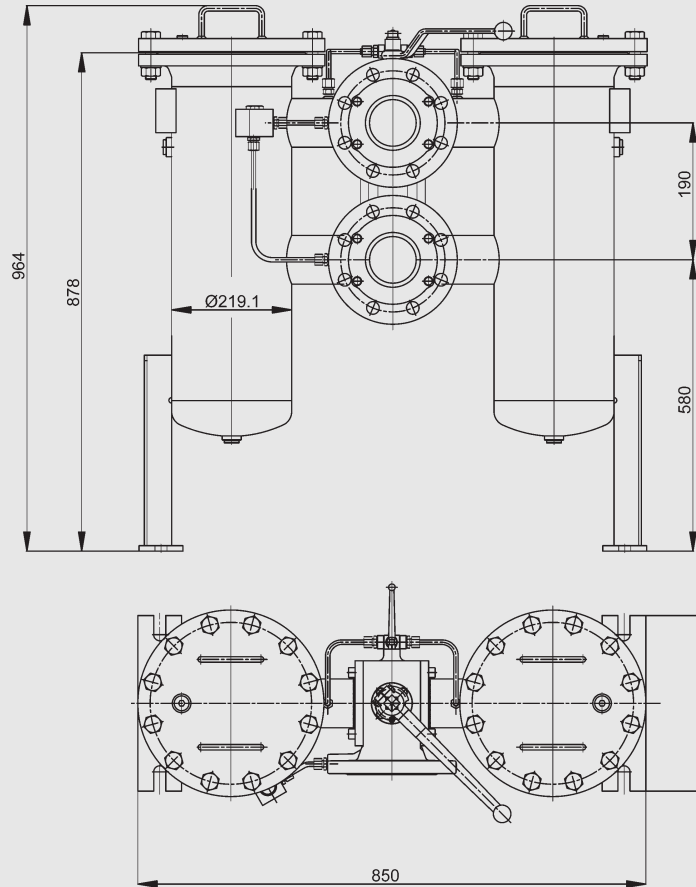

PRFSD 250x

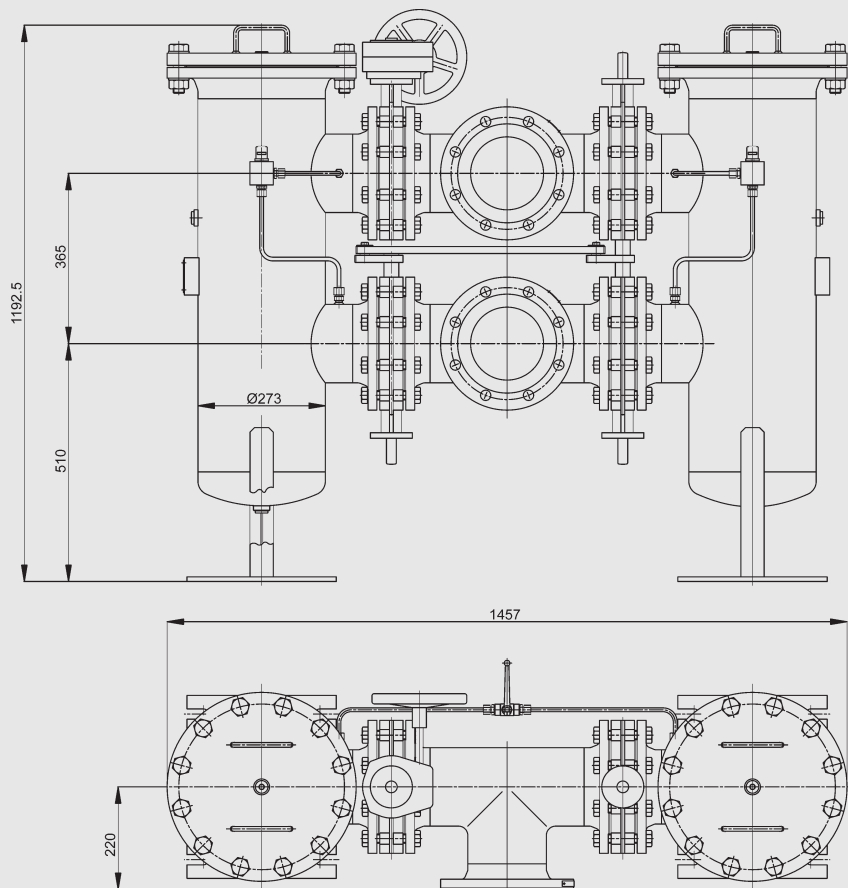

- The filter must not be used as a pipe support
- The dimensions quoted have ± 10 mm tolerances

PRFSD 520x

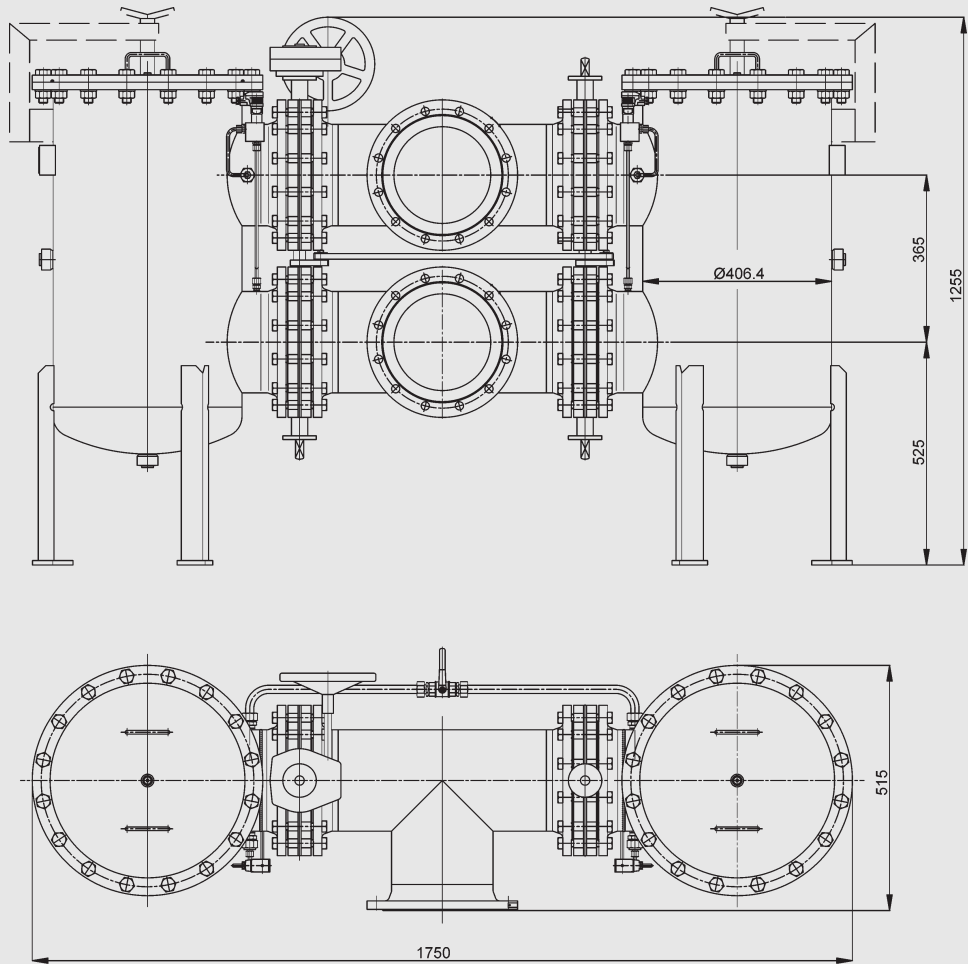

PRFSD 650x

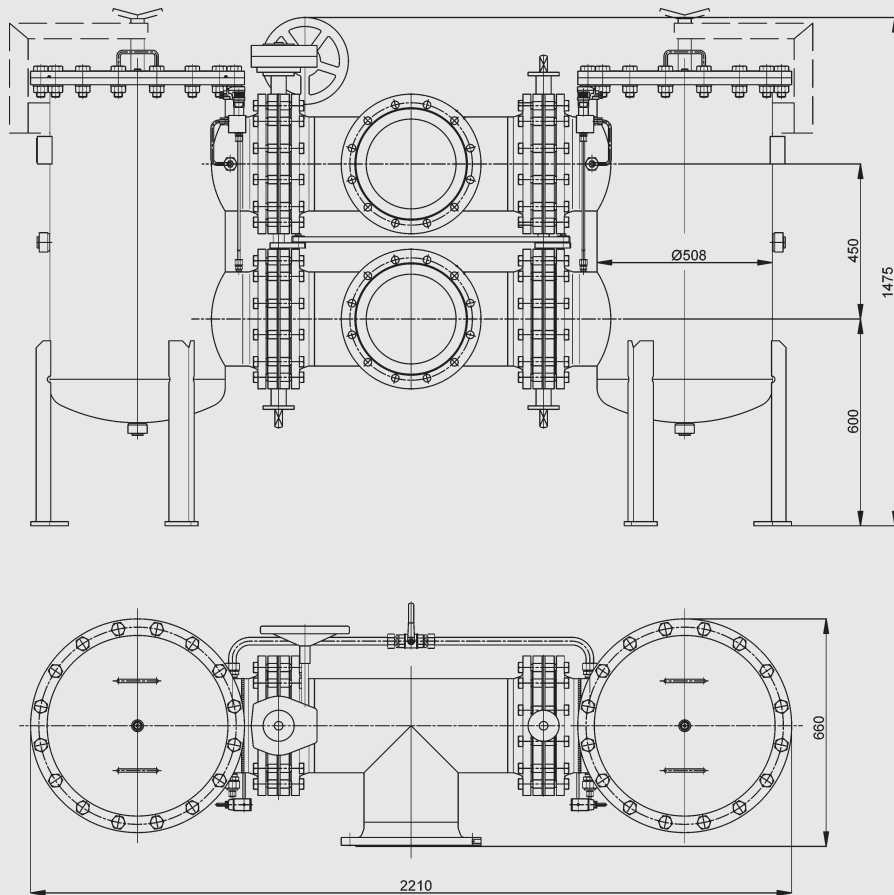

- The filter must not be used as a pipe support
- The dimensions quoted have ± 10 mm tolerances

PRFSD 1500x

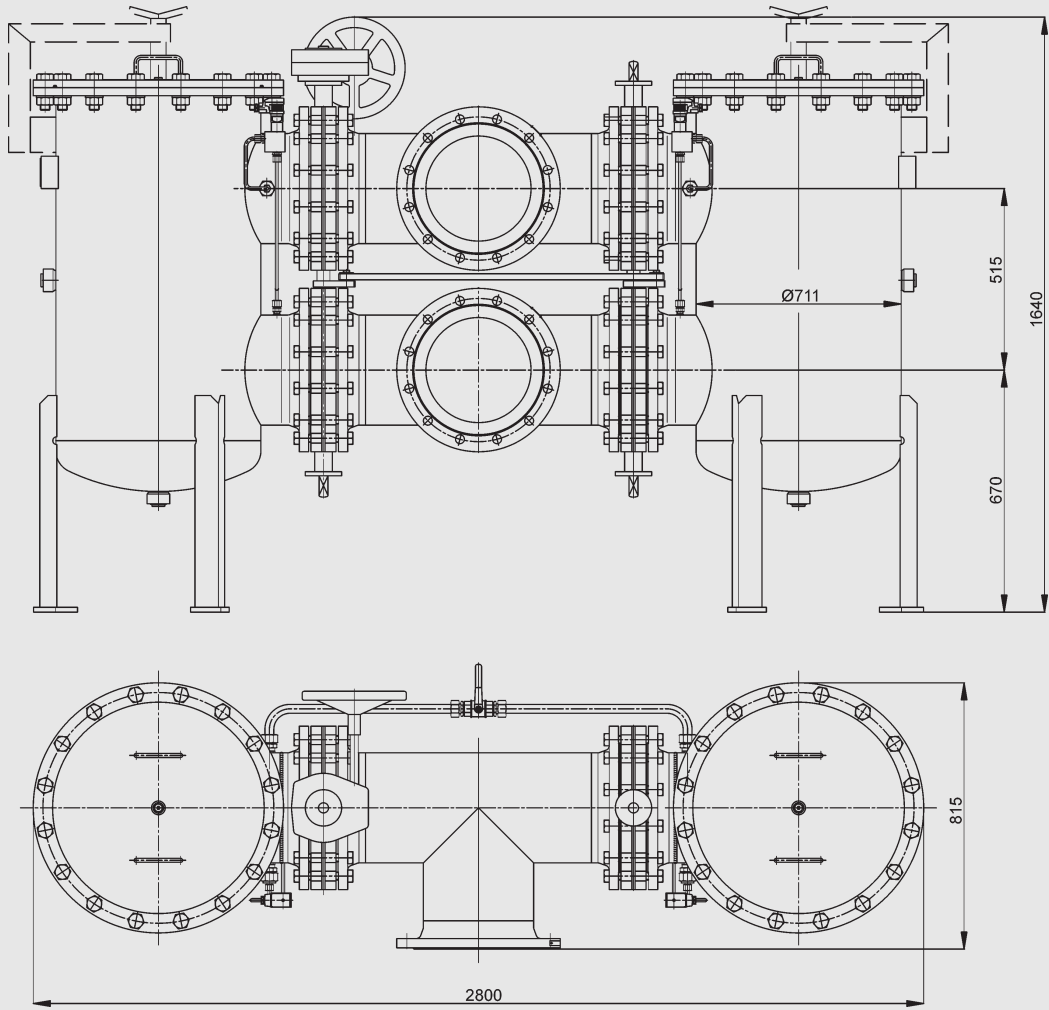

- The filter must not be used as a pipe support
- The dimensions quoted have ± 10 mm tolerances

5.2 FILTER ELEMENT

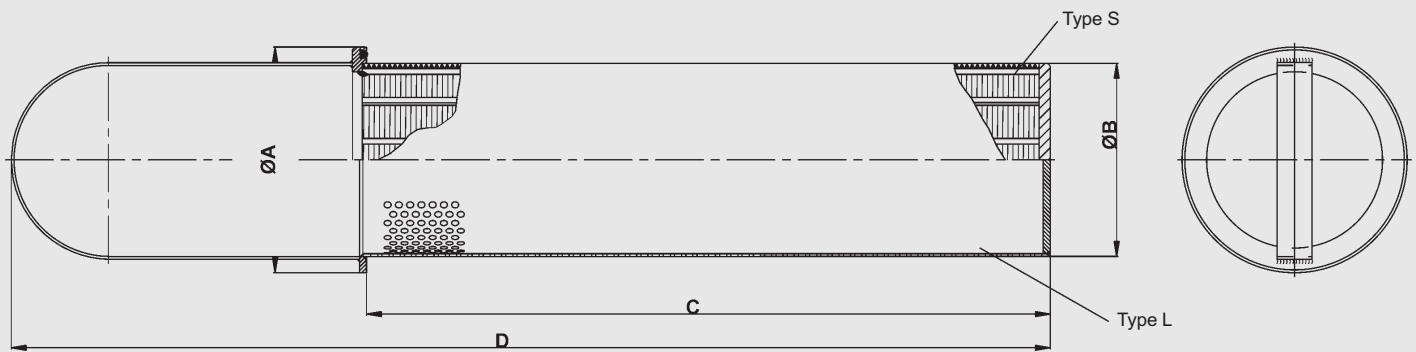

Size	A	B	C	D
SK-3	160	137	486	738.5
SK-4	187	164	566	913
SK-5	300	260	910	1619

NOTE

The information in this brochure relates to the operating conditions and applications described. For applications or operating conditions not described, please contact the relevant technical department.

Subject to technical modifications.

HYDAC Process Technology GmbH
 Am Wrangelflöz 1
D-66538 Neunkirchen
 Tel.: 0 68 21 / 86 90 - 0
 Fax: 0 68 21 / 86 90 - 200
 Internet: www.hydac.com
 E-Mail: prozess-technik@hydac.com

