



PY2033

PN-025-RDR12-MFRKG/US/ IV



Pressure sensors

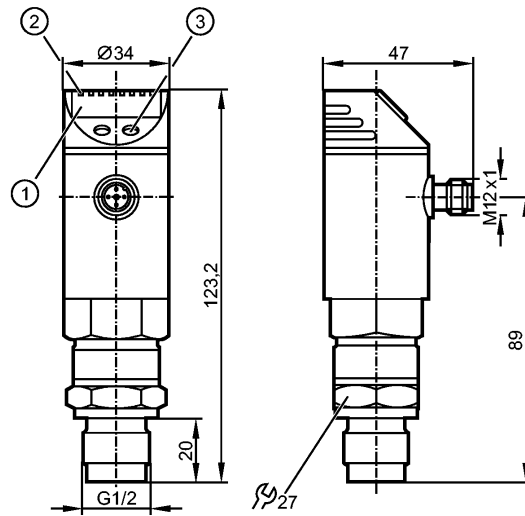

- 1: 4-digit alphanumeric display
- 2: LEDs (display unit / switching status)
- 3: Programming button



Product characteristics

Combined pressure sensor

Quick disconnect

Zero and span adjustable

Function programmable

no dead space

Process connection: G 1/2 A

2 outputs

OUT1 = switching output

OUT2 = switching output or analog output

4-digit alphanumeric display

Measuring range: -1...25 bar / -14.5...362.5 psi / -0.1...2.5 MPa

Application

Application	Type of pressure: relative pressure Liquids and gases		
Pressure rating	100 bar	1450 psi	10 MPa
Bursting pressure min.	200 bar	2900 psi	20 MPa
Medium temperature [°C]	-25...80		

Electrical data

Electrical design	DC PNP/NPN
Operating voltage [V]	18...32 DC ¹⁾
Current consumption [mA]	< 35
Insulation resistance [MΩ]	> 100 (500 V DC)
Protection class	III
Reverse polarity protection	yes

Outputs

Output	2 outputs OUT1 = switching output OUT2 = switching output or analog output
Output function	2 x normally open / closed programmable or 1 x normally open / closed programmable + 1 x analog (4...20 mA / 0...10 V; programmable 1:4)



PY2033

PN-025-RDR12-MFRKG/US/ IV



Pressure sensors

Current rating	[mA]	2 x 250
Voltage drop	[V]	< 2
Short-circuit protection		yes (non-latching)
Overload protection		yes
Switching frequency	[Hz]	≤ 500
Analog output		4...20 mA / 0...10 V
Max. load	[Ω]	4...20 mA: max. (U _b - 10 V) x 50 / 0...10 V: min. 2000

Measuring / setting range			
Measuring range	-1...25 bar	-14.5...362.5 psi	-0.1...2.5 MPa
Setting range			
Set point, SP	-0.80...25.00 bar	-11.5...362.5 psi	-0.08...2.50 MPa
Reset point, rP	-0.90...24.90 bar	-13.0...361.0 psi	-0.09...2.49 MPa
Analog start point, ASP	-1.00...18.75 bar	-14.5...272.0 psi	-0.10...1.88 MPa
Analog end point, AEP	5.25...25.00 bar	76.0...362.5 psi	0.53...2.50 MPa
in steps of	0.05 bar	0.5 psi	0.01 MPa
Factory setting	SP1 = 6.25 bar; rP1 = 5.75 bar SP2 = 18.75 bar; rP2 = 18.25 bar ASP = 0.00 bar; AEP = 25.00 bar		

Accuracy / deviations	
Accuracy / deviations (in % of the span) Turn down 1:1	
Switch point accuracy	< ± 0.4
Characteristics deviation *)	< ± 0.3 (BFSL) / < ± 0.6 (LS)
Linearity	< ± 0.5
Hysteresis	< ± 0.1
Repeatability **)	< ± 0.1
Long-term stability ***)	< ± 0.1
Temperature coefficients (TEMPCO) in the temperature range 0...80° C (in % of the span per 10 K)	
Greatest TEMPCO of the zero point	< ± 0.25
Greatest TEMPCO of the span	< ± 0.25

Reaction times	
Power-on delay time	[s] 0.3
Min. response time switching output	[ms] 1.5
Damping for the switching output (dAP)	[s] 0; 0.01...4.00
Damping for the analog output (dAA)	[s] 0; 0.01...4.00
Response time analog output	[ms] 3
Integrated watchdog	yes

Software / programming	
Programming options	hysteresis / window function; N.O. / N.C.; output polarity; current / voltage outputs; damping; calibration of displayed values; display can be rotated / deactivated; display unit

Environment	
Ambient temperature	[°C] -25...80
Storage temperature	[°C] -40...100
Protection	IP 65



PY2033

PN-025-RDR12-MFRKG/US/ IV



Pressure sensors

Tests / approvals

EMC	DIN EN 61000-6-2 DIN EN 61000-6-3	
Shock resistance	DIN EN 60068-2-27	50 g (11 ms)
Vibration resistance	DIN EN 60068-2-6	20 g (10...2000 Hz)
MTTF [Years]	167.14	

Mechanical data

Process connection	G ½ A	
Materials (wetted parts)	stainless steel 316L / 1.4435	
Housing materials	stainless steel (304S15); stainless steel 316L / 1.4435; PC; PBT; PEI; PTFE	
Switching cycles min.	10 million	
Weight [kg]	0.39	

Displays / operating elements

Display	Display unit 3 x LED green Switching status 2 x LED yellow Function display 4-digit alphanumeric display Measured values 4-digit alphanumeric display
---------	--

Electrical connection

Connection	M12 connector; gold-plated contacts
------------	-------------------------------------

Wiring

- Core colors
- BK black
 - BN brown
 - BU blue
 - WH white

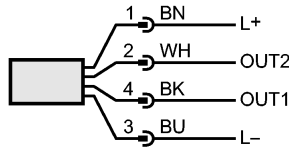

OUT1: Switching output
 OUT2: switching output / analogue output
 Colours to DIN EN 60947-5-2

Remarks

Remarks	1) to EN50178, SELV, PELV *) BFSL = Best Fit Straight Line / LS = Limit Value Setting **) with temperature fluctuations < 10 K ***) in % of the span per year
---------	--

Pack quantity [piece]	1
-----------------------	---