



QTM2

FLOW RESTRICTOR VALVE

SERIES 10

MODULAR VERSION
ISO 4401-02 (CETOP R02)

p max 320 bar
Q max 30 l/min

MOUNTING SURFACE

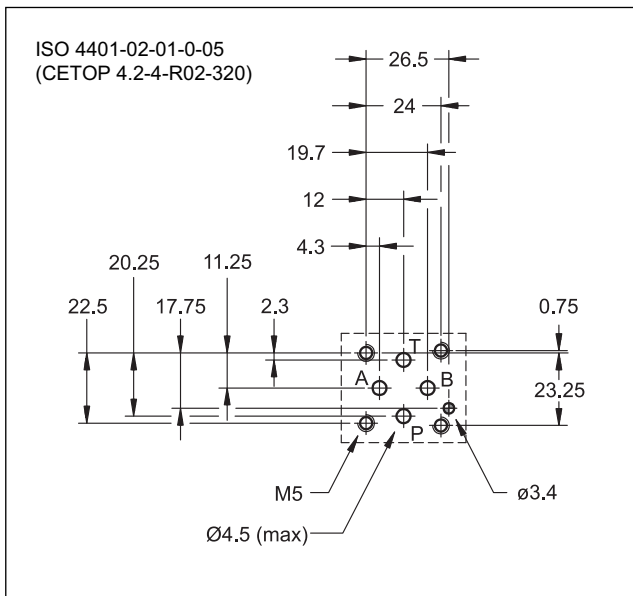

OPERATING PRINCIPLE

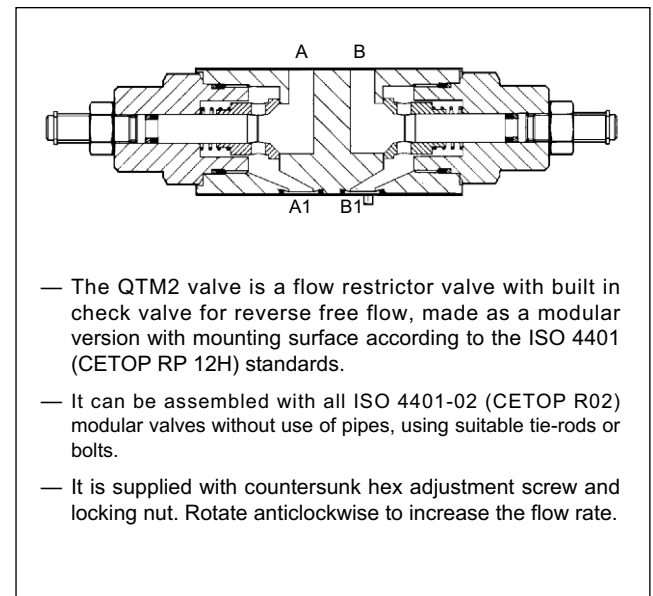

PERFORMANCES (measured with mineral oil of viscosity 36cSt at 50°C)

Maximum operating pressure	bar	320
Maximum flow rate	l/min	30
Ambient temperature range	°C	-20 / +50
Check valve opening pressure	bar	0,4
Fluid temperature range	°C	-20 / +80
Fluid viscosity range	cSt	10 ÷ 400
Fluid contamination degree	According to ISO 4406:1999 class 20/18/15	
Recommended viscosity	cSt	25
Mass	kg	0,8

HYDRAULIC SYMBOLS

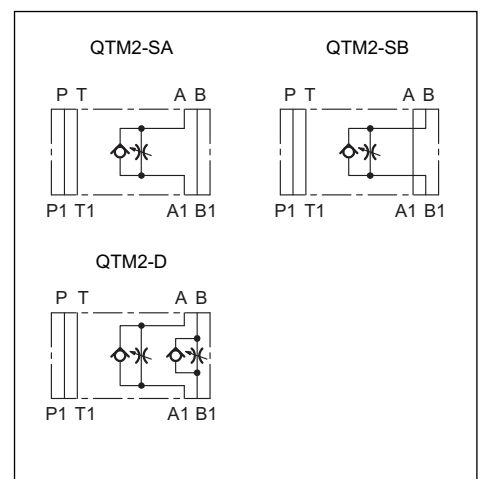

1 - IDENTIFICATION CODE

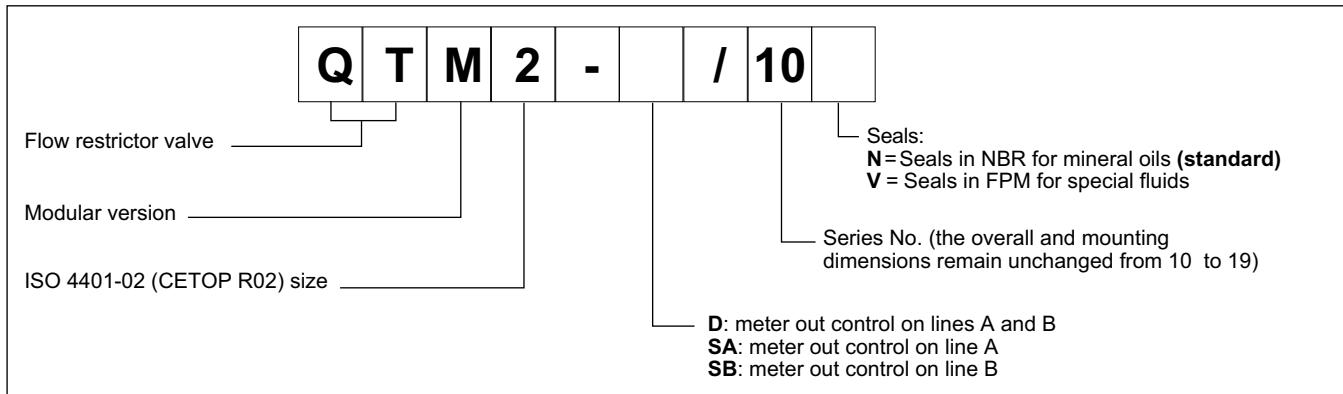

2 - CHARACTERISTIC CURVES (values obtained with viscosity of 36 cSt at 50°C)

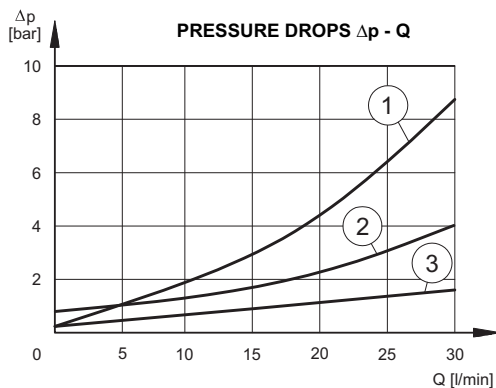

Typical $\Delta p - Q$ curves obtained with QTM2-D valve, with throttling axis at full retraction.

- 1) pressure drops A₁ - A (B₁ - B)
- 2) pressure drops A - A₁ (B - B₁)
- 3) pressure drops through the free ports

3 - HYDRAULIC FLUIDS

Use mineral oil-based hydraulic fluids HL or HM type, according to ISO 6743-4. For these fluids, use NBR seals. For fluids HFDR type (phosphate esters) use FPM seals (code V). For the use of other kinds of fluid such as HFA, HFB, HFC, please consult our technical department. Using fluids at temperatures higher than 80 °C causes a faster degradation of the fluid and of the seals characteristics. The fluid must be preserved in its physical and chemical characteristics.

4 - OVERALL AND MOUNTING DIMENSIONS

