

Pressure reducing valves

Hydraulic diagram	Type	Description	Maximum flow up to		Maximum pressure		Page
			l/min	US gpm	bar	psi	
	RD..W	Proportional pressure control valve, reducing/relieving, direct-operated, spool-type	4	1	350	5100	33

Operation

The RD..W permits free oil flow from 2 to 1 while port 3 is always connected to tank. when pressure in 1 is the same as the valve set pressure, the spool restricts the passage between 2 and 1 so that pressure in 1 remains constant. When inlet pressure in 1 exceeds the setting of the valve, the pilot section 2 closes causing an imbalance across the main spool which then opens allowing relief flow to tank (3). Push-button operation allowed. (If used with energized magnet, the valve will change the actual pressure setting).

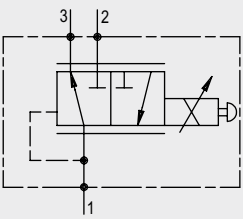
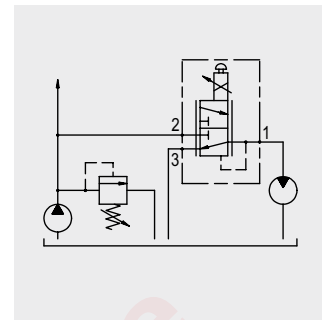

Performance

Type RD..W	Maximum flow		Maximum pressure		Nominal and maximum current settings*	Current Dither frequency (Hz)	Hysteresis with 150 Hz current Dither frequency	Relieving pressure range from threshold to maximum control current	Cavities and tools	Weight	
	l/min	US gpm	bar	psi						kg	lb
RD08W	4	1	350	5100	1,25A per bobine 12V 0,68A per bobine 24V	150	3-4%	1) 0 ÷ 25	see cavity SAE 8-3 page 66	0,68	1.50

*For further information see page 57 M.P.35X35

Dimensions and hydraulic circuit

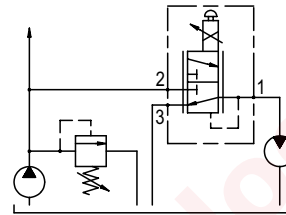
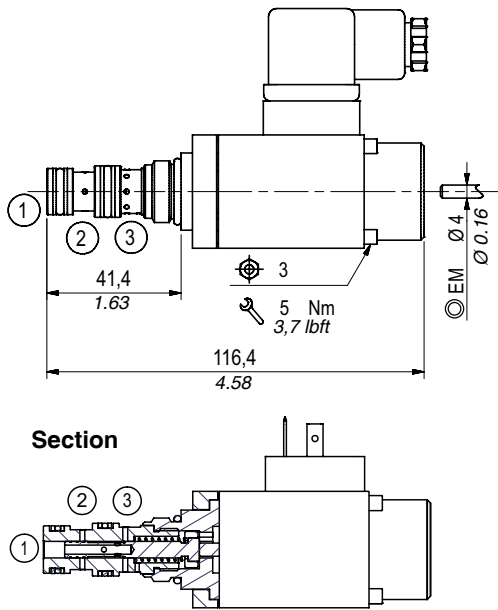

Rating diagrams

Typical Pressure drop vs. flow characteristic 2 → 1
Oil viscosity 46j cSt at 40j C

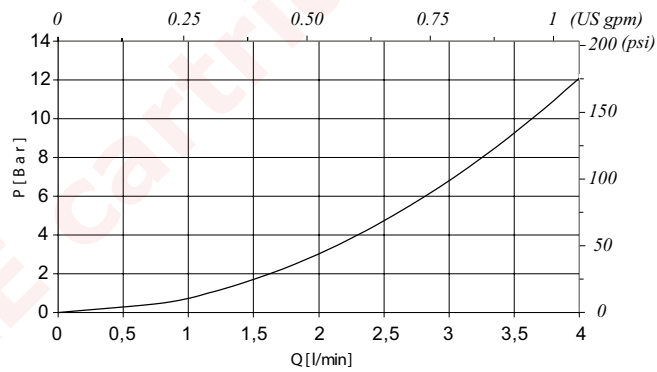

Typical Pressure drop vs. flow characteristic 1 → 3
with de-energized coil
Oil viscosity 46j cSt at 40j C

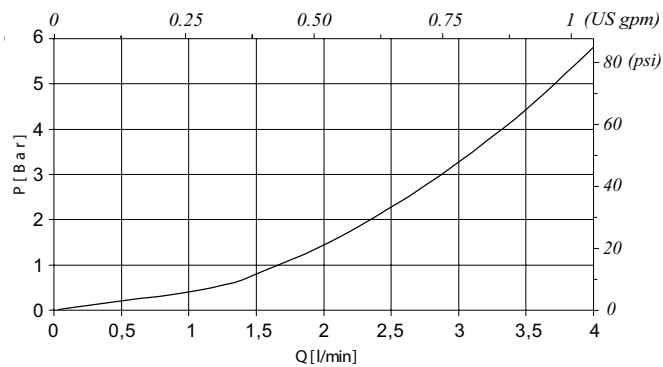

Pressure setting diagram - % of the max control current

Power supply 12/24 Volt
Oil viscosity 46 cSt at 40°C

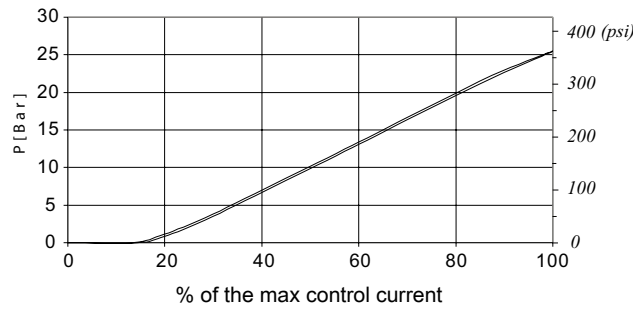

Pressure adjustments diagram pressure/flow

at change ment in % of the max control current
Pressure setting 2 (50-200 bar) - Power supply 12/24 Volt
Oil viscosity 46 cSt at 40°C

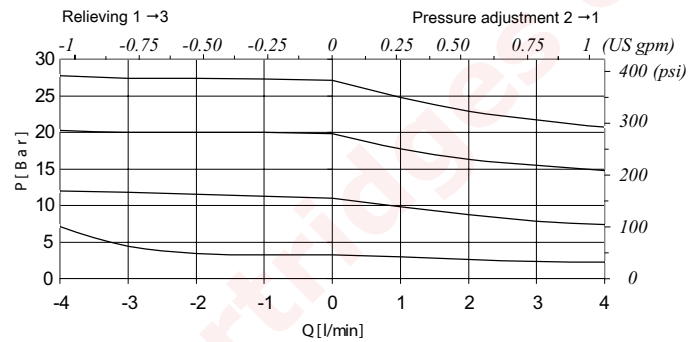

Order code

RD08W / 0 -□ -□ -□

Power supply (Volt)

- 2) 12 Vcc
- 4) 24 Vcc

Pressure settings

- 1) 0÷25 bar (0÷360 psi)

Seals

- B) Buna
- V) Viton

Description and operation

This chapter show main adjusting devices for the valves listed in this catalog.
These regulations are used to adjust flow rate between inlet and working ports.

Performance

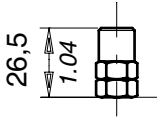
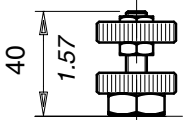
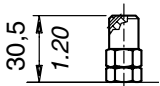
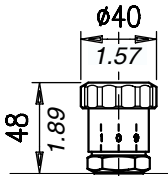
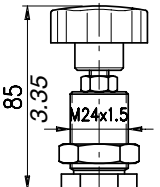
	<p>Screw "S"</p>		<p>Handknob "V"</p>
	<p>Copped adjustment "W"</p>		<p>Handknob "MG"</p>
	<p>Handknob "PV"</p>		

Dimensions

Material	Max. pressure	
	bar	psi
Aluminium	210	3050
Steel	350	5100

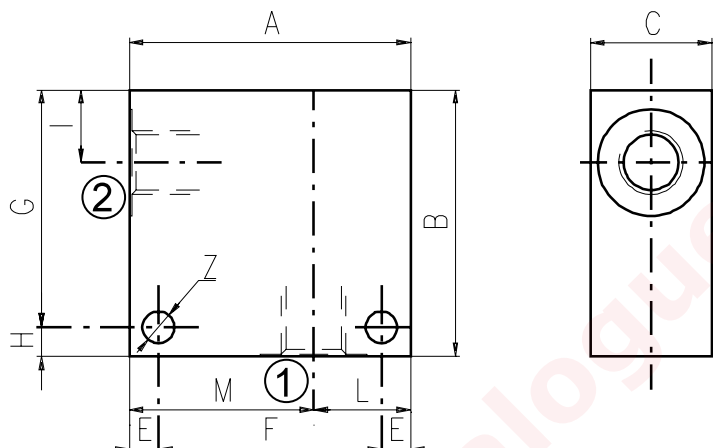

Cavità	Attacchi		A	B	C	E	F	G	H	I	L	M	Z
SAE 8/2	G 1/2	mm	70	65	35	7	56	53	12	14,5	35	35	6,5
		in	2.75	2.56	1.38	0.27	2.20	2.09	0.47	0.57	1.38	1.38	0.25
	G 1/4	mm	50	50	30	6	38	44	6	14,8	20	30	6,5
		in	1.97	1.97	1.18	0.24	1.50	1.73	0.24	0.58	0.79	1.18	0.25
	G 3/8	mm	50	50	30	6	38	44	6	14,8	20	30	6,5
		in	1.97	1.97	1.18	0.24	1.50	1.73	0.24	0.58	0.79	1.18	0.25
SAE6	mm	50	50	30	6	38	44	6	14,8	20	30	6,5	
	in	1.97	1.97	1.18	0.24	1.50	1.73	0.24	0.58	0.79	1.18	0.25	
SAE 10/2	G 1/4	mm	60	60	35	6	48	54	6	18,8	25	35	6,5
		in	2.36	2.36	1.38	0.24	1.89	2.12	0.24	0.74	0.98	1.38	0.25
	G 3/8	mm	60	60	35	6	48	54	6	18,8	25	35	6,5
		in	2.36	2.36	1.38	0.24	1.89	2.12	0.24	0.74	0.98	1.38	0.25
	G 1/2	mm	60	60	35	6	48	54	6	18,8	25	35	6,5
		in	2.36	2.36	1.38	0.24	1.89	2.12	0.24	0.74	0.98	1.38	0.25
	SAE8	mm	60	70	35	6	48	64	6	18,8	25	35	6,5
		in	2.36	2.75	1.38	0.24	1.89	2.52	0.24	0.74	0.98	1.38	0.25
	SAE10	mm	70	70	35	6	58	64	6	18,5	35	35	6,5
		in	2.75	2.75	1.38	0.24	2.28	2.52	0.24	0.73	1.38	1.38	0.25
SAE12	mm	70	70	40	8	54	62	8	22	30	40	8,5	
	in	2.75	2.75	1.57	0.31	2.12	2.44	0.31	0.87	1.18	1.57	0.33	
SAE 12/2	G 1/2	mm	70	80	40	8	54	72	8	25	30	40	8,5
		in	2.75	3.15	1.57	0.31	2.12	2.83	0.31	0.98	1.18	1.57	0.33
	G 3/4	mm	70	90	40	8	54	82	8	25	30	40	8,5
		in	2.75	3.54	1.57	0.31	2.12	3.23	0.31	0.98	1.18	1.57	0.33
	SAE10	mm	70	85	40	8	54	77	8	25	30	40	8,5
		in	2.75	3.35	1.57	0.31	2.12	3.03	0.31	0.98	1.18	1.57	0.33
	SAE12	mm	70	85	40	8	54	77	8	25	30	40	8,5
		in	2.75	3.35	1.57	0.31	2.12	3.03	0.31	0.98	1.18	1.57	0.33

Cavità	Attacchi	A	B	C	E	F	G	H	I	L	M	Z	
SAE 16/2	G 1/2	mm	80	90	50	10	60	80	10	25	35	45	10,5
		in	3.15	3.54	1.97	0.39	2.36	3.15	0.39	0.98	1.38	1.77	0.41
	G 3/4	mm	80	90	50	10	60	80	10	25	35	45	10,5
		in	3.15	3.54	1.97	0.39	2.36	3.15	0.39	0.98	1.38	1.77	0.41
	G 1	mm	85	100	60	10	65	90	10	23,5	40	45	10,5
		in	3.35	3.94	2.36	0.39	2.56	3.54	0.39	0.92	1.57	1.77	0.41
	SAE12	mm	80	90	50	10	60	80	10	25	35	45	10,5
		in	3.15	3.54	1.97	0.39	2.36	3.15	0.39	0.98	1.38	1.77	0.41
	SAE16	mm	80	100	50	10	60	90	10	25	35	45	10,5
		in	3.15	3.94	1.97	0.39	2.36	3.54	0.39	0.98	1.38	1.77	0.41

Order code

3/CC /- □ □ /20/□- □-1

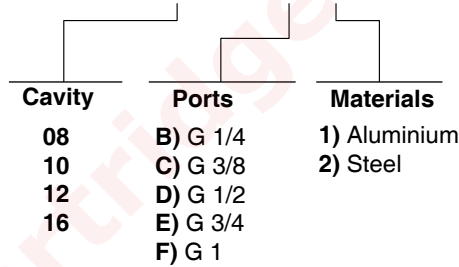

Dimensions

Material	Max. pressure bar	
	bar	psi
Alluminium	210	3050
Steel	350	5100

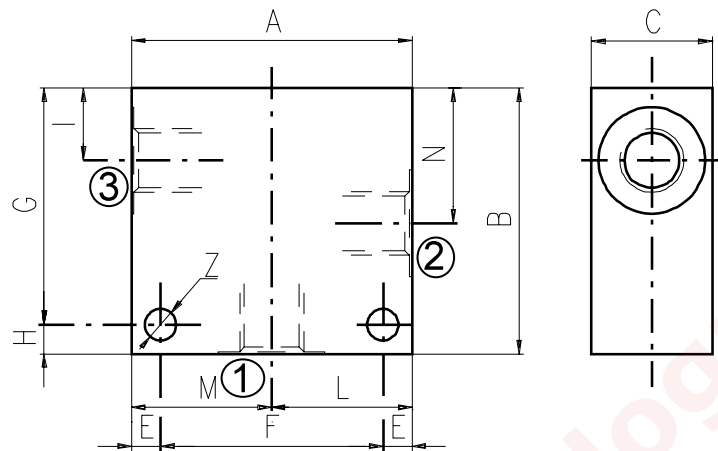

Cavity	Ports		A	B	C	E	F	G	H	I	L	M	N	Z
SAE 8/3	G 1/4	mm	60	60	30	7	46	48	12	14,8	30	30	29,1	6,5
		in	2.36	2.36	1.18	0.27	1.81	1.89	0.47	0.58	1.18	1.18	1.14	0.25
	G 3/8	mm	60	60	30	7	46	48	12	14,5	30	30	29,1	6,5
		in	2.36	2.36	1.18	0.27	1.81	1.89	0.47	0.57	1.18	1.18	1.14	0.25
	G 1/2	mm	70	65	35	7	56	53	12	14,5	35	35	29,1	6,5
		in	2.75	2.56	1.38	0.27	2.20	2.09	0.47	0.57	1.38	1.38	1.14	0.25
	SAE6	mm	60	60	30	7	46	48	12	14,5	30	30	29,1	6,5
		in	2.36	2.36	1.18	0.27	1.81	1.89	0.47	0.57	1.18	1.18	1.14	0.25
SAE 10/3	G 1/4	mm	60	65	35	6	48	59	6	18	30	30	34,5	7
		in	2.36	2.56	1.38	0.24	1.89	2.32	0.24	0.70	1.18	1.18	1.36	0.27
	G 3/8	mm	60	65	35	6	48	59	6	18,8	30	30	34,5	7
		in	2.36	2.56	1.38	0.24	1.89	2.32	0.24	0.74	1.18	1.18	1.36	0.27
	G 1/2	mm	65	70	35	6	53	64	6	18,8	32,5	32,5	34,5	7
		in	2.56	2.75	1.38	0.24	2.09	2.52	0.24	0.74	1.28	1.28	1.36	0.27
	SAE6	mm	65	70	35	6	53	64	6	18,8	32,5	32,5	34,5	7
		in	2.56	2.75	1.38	0.24	2.09	2.52	0.24	0.74	1.28	1.28	1.36	0.27
	SAE8	mm	65	70	35	6	53	64	6	18,8	32,5	32,5	34,5	7
		in	2.56	2.75	1.38	0.24	2.09	2.52	0.24	0.74	1.28	1.28	1.36	0.27
SAE 12/3	G 1/2	mm	70	100	40	8	54	92	8	25	35	35	53,5	8,5
		in	2.75	3.94	1.57	0.31	2.12	3.6	0.31	0.98	1.38	1.38	2.10	0.33
	G 3/4	mm	90	100	50	10	70	90	10	25,1	45	45	53,5	10,5
		in	3.54	3.94	1.97	0.39	2.75	3.54	0.39	0.99	1.77	1.77	2.11	0.41
	SAE10	mm	80	100	40	8	64	92	8	25	40	40	53,5	8,5
		in	3.15	3.94	1.57	0.31	2.52	3.6	0.31	0.98	1.57	1.57	2.11	0.33
	SAE12	mm	80	100	45	8	64	92	8	25	40	40	53,5	8,5
		in	3.15	3.94	1.57	0.31	2.52	3.6	0.31	0.98	1.57	1.57	2.11	0.33
SAE 16/3	G 3/4	mm	90	100	50	10	70	90	10	25,1	45	45	53,5	10,5
		in	3.54	3.94	1.97	0.39	2.75	3.54	0.39	0.99	1.77	1.77	2.11	0.41
	SAE12	mm	90	105	50	10	70	95	10	25,1	45	45	53,5	10,5
		in	3.54	4.13	1.97	0.39	2.75	3.74	0.39	0.99	1.77	1.77	2.11	0.41
	SAE16	mm	90	105	50	10	70	95	10	25,1	45	45	53,5	10,5
		in	3.54	4.13	1.97	0.39	2.75	3.74	0.39	0.99	1.77	1.77	2.11	0.41

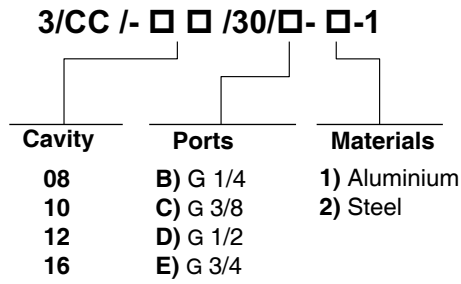

see SAE cartridges catalogue

Dimensions

Material	Max. pressure bar	
	bar	psi
Aluminium	210	3050
Steel	350	5100

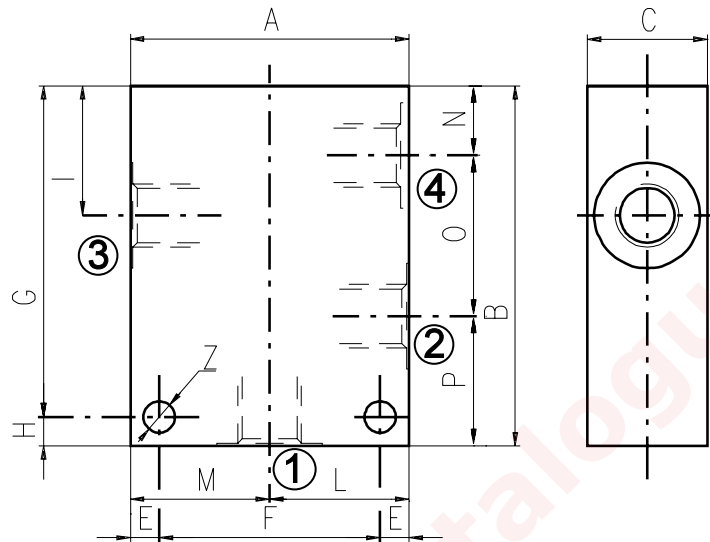

Cavity	Ports	A	B	C	E	F	G	H	I	L	M	N	O	P	Z	
SAE 8/4	G 1/4	mm	60	75	30	7	46	63	12	29,1	30	30	14,8	29,1	31,1	6,5
		in	2.36	2.95	1.18	0.27	1.81	2.48	0.47	1.14	1.18	1.18	0.58	1.14	1.22	0.25
	SAE6	mm	60	75	30	7	46	63	12	29,1	30	30	14,8	29,1	31,1	6,5
		in	2.36	2.95	1.18	0.27	1.81	2.48	0.47	1.14	1.18	1.18	0.58	1.14	1.22	0.25
SAE 10/4	G 3/8	mm	60	85	35	6	48	79	6	34,5	30	30	18,8	31,7	34,5	7
		in	2.36	3.35	1.38	0.24	1.89	3.11	0.24	1.36	1.18	1.18	0.74	1.25	1.36	0.27
	G 1/2	mm	70	85	35	6	58	79	6	34,5	35	35	18,8	31,7	34,5	7
		in	2.75	3.35	1.38	0.24	2.28	3.11	0.24	1.36	1.38	1.38	0.74	1.25	1.36	0.27
	SAE6	mm	60	85	35	6	48	79	6	34,5	30	30	18,8	31,7	34,5	7
		in	2.45	3.35	1.38	0.24	1.89	3.11	0.24	1.36	1.18	1.18	0.74	1.25	1.36	0.27
SAE8	mm	70	85	35	6	58	79	6	34,5	35	35	18,8	31,7	34,5	7	
	in	2.75	3.35	1.38	0.24	2.28	3.11	0.24	1.36	1.38	1.38	0.74	1.25	1.36	0.27	
SAE 12/4	G 1/2	mm	80	115	40	8	64	107	8	44	40	40	22	44,5	48,5	8,5
		in	3.15	4.53	1.57	0.31	2.52	4.21	0.31	1.73	1.57	1.57	0.87	1.75	1.9	0.33
	SAE10	mm	80	115	40	8	64	107	8	44	40	40	22	44,5	48,5	8,5
		in	3.15	4.53	1.57	0.31	2.52	4.21	0.31	1.73	1.57	1.57	0.87	1.75	1.9	0.33
SAE 16/4	G 3/4	mm	100	130	50	10	80	120	10	53,5	50	50	25,1	56,9	48	10,5
		in	3.94	5.12	1.97	0.39	3.15	4.72	0.39	2.11	1.97	1.97	0.99	2.24	1.89	0.41

Order code

3/CC /- □ □ /40/□- □-1

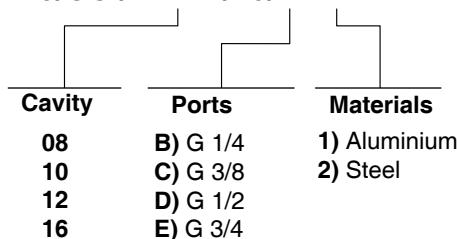

How to order valves with body

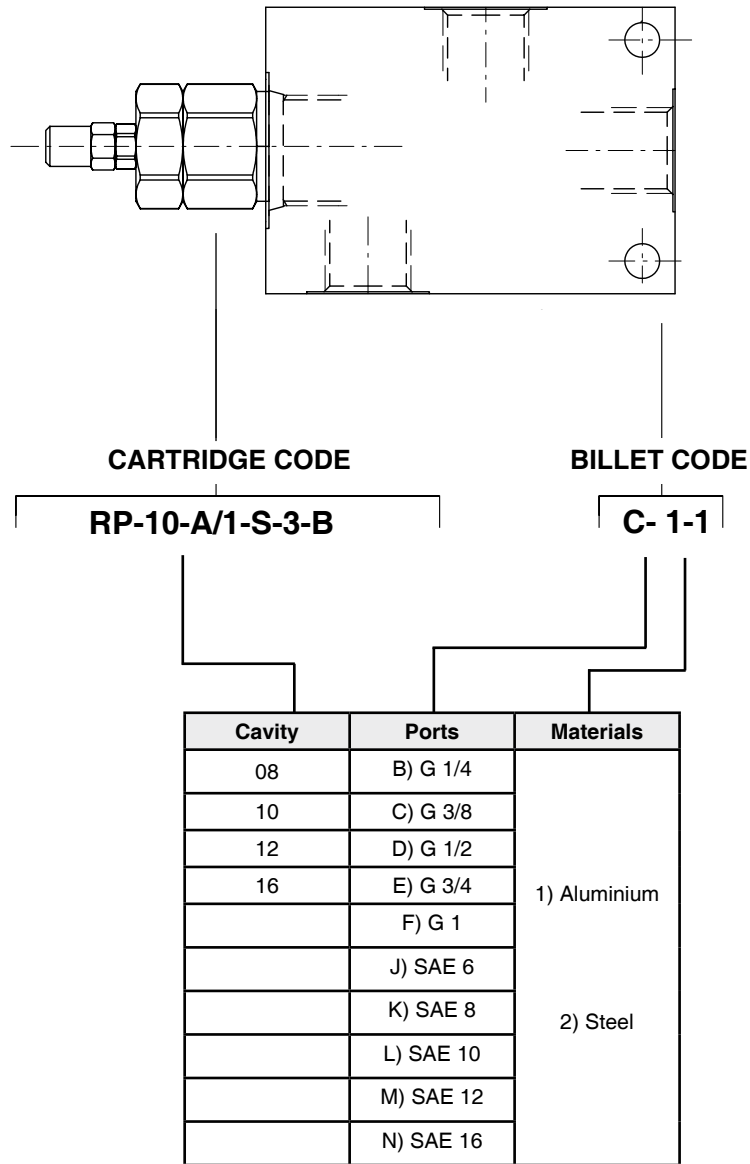

Dimensions

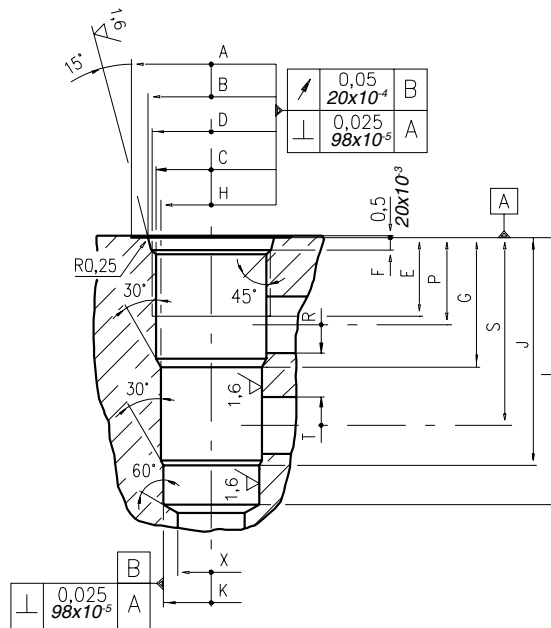

\	A	B ±0,05	C ±0,05	D	E	F	G	H ±0,02	J	K ±0,02	L	M ±0,02	N	P	R øMAX	S	T øMAX	U	V øMAX	X øMAX	Z øMIN	Prof. Z MIN	
08/3	mm	27	20,66	17,42	3/4-16 UNF	12,50	2,5	19,10	15,90	33,30	14,30	43,30	-	-	14,30	5,50	28,60	5,50	-	-	12,50	-	-
	in	1.06	0.81	0.68		0.49	0.10	0.75	0.62	1.31	0.56	1.70	-	-	0.56	0.22	1.12	0.22	-	-	0.49	-	-
10/3	mm	30	24,00	20,62	7/8-14 UNF	16,00	2,80	23,10	17,50	39,60	15,90	47,60	-	-	18,30	6,50	34,00	6,50	-	-	14,00	-	-
	in	1.18	0.94	0.81		0.63	0.11	0.94	0.69	1.56	0.62	1.87	-	-	0.72	0.25	1.34	0.25	-	-	0.55	-	-
12/3	mm	38	29,23	24,73	1 1/16-12 UNF	19,00	3,56	36,60	23,82	63,50	22,25	75,40	-	-	24,50	16,00	53,00	16,00	-	-	19,00	-	-
	in	1.50	1.15	0.97		0.75	0.14	1.44	0.94	2.5	0.88	2.97	-	-	0.96	0.63	2.09	0.63	-	-	0.75	-	-
16/3	mm	45	35,6	31,34	1 5/16-12 UNF	22,00	3,5	36,50	28,62	64,30	27,02	75,38	-	-	24,60	16,00	53,00	16,00	-	-	19,00	-	-
	in	1.77	1.40	1.23		0.87	0.14	1.44	1.13	2.53	1.06	2.97	-	-	0.97	0.63	2.09	0.63	-	-	0.75	-	-

Rougher tool

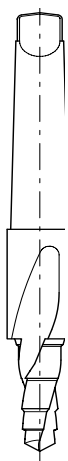

Cavity	Code number
08/3	3UT00052190
10/3	3UT00054170
12/3	3UT00054290
16/3	3UT00054470

Finisher tool



Cavity	Code number
08/3	3UT00052740
10/3	3UT00054180
12/3	3UT00054300
16/3	3UT00054480

Tap

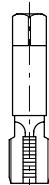

Cavity	Code number
08/3	3UT03416UNF
10/3	3UT07814UNF
12/3	3UT0111612UN
16/3	3UT0151612UN

Cavity plugs

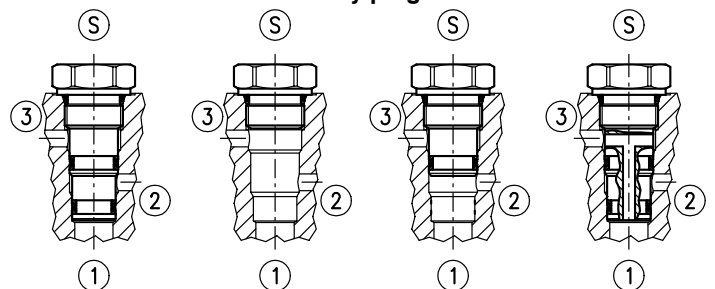

Cavity	Code number	①	②	③	Ⓢ
08/3	3XTP3535100	X	X	X	X
	4TP5531500	0	0	0	X
	3XTP3534000	0	0	X	X
	3XTP3534800	0	X	0	X
10/3	3XTP3545700	X	X	X	X
	3XTP1542300	0	0	0	X
	3XTP3545701	0	X	0	X
12/3	3XTP3558200	X	X	X	X
	3XTP1552900	0	0	0	X
	3XTP35558201	0	X	0	X
16/3	3XTP3578400	X	X	X	X
	3XTP1572900	0	0	0	X

X=Closed 0=Open