



**Hidro  
Pnevmo  
Tehnika**

3, Vojeli St., Kazanlak, Bulgaria  
Tel.: +359 431/ 62 228  
e-mail: info@hpt-bg.com  
www.hpt-bg.com

## SOLENOID OPERATED DIRECTIONAL CONTROL VALVE

### RHB06- .. / ... -2

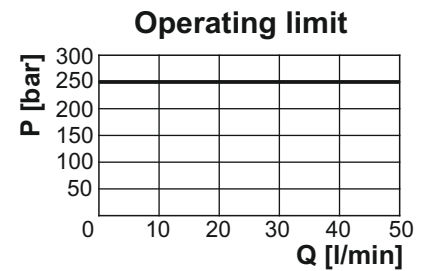
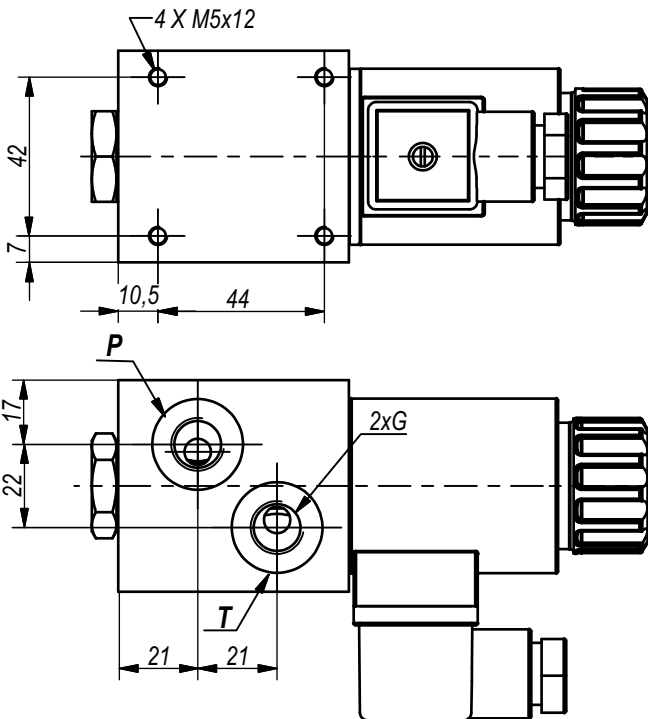
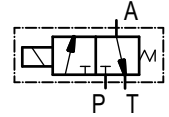
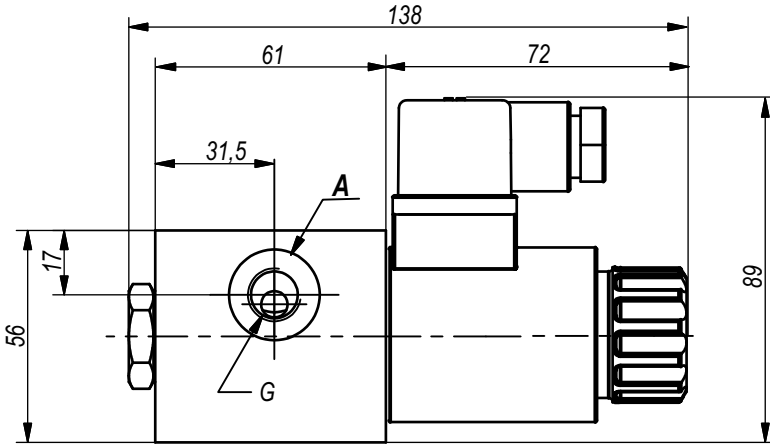
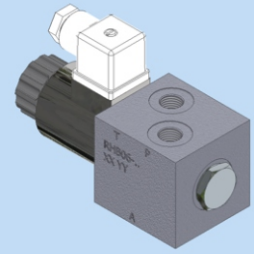

Internal leakage - 8 cm<sup>3</sup>/min  
mineral oil with 46 cSt viscosity  
and at 100 bar pressure

**Note:**

1. All performances and calibration are carried out by using hydraulic oil with viscosity approx 46 cSt at 50 °C.
2. Tightening torque for the solenoid - 25 N.m.

TECHNICAL DATA		
General		
Ambient temperature	°C	-20...+50
Hydraulic		
Maximal pressure	bar	250
Maximal flow rate	L/min	30
Working fluid - mineral oil		
- viscosity	mm <sup>2</sup> /s	10...100
- filtration level	µm	25 or better
- temperature	°C	-20...+80
Power supply		
Voltage	V DC	12±5% 24±5%
	V AC	110/50Hz 220/50Hz

### ORDERING CODE

**RHB06 - .. / 12 P - 2**

Series

Type

Port threads "G" - code:  
**M14x1,5 - omit**  
**G3/8" - 38**

Operating voltage - code:  
**12V / 00Hz - 12**  
**24V / 00Hz - 24**  
**110V/50Hz - 110**  
**220V/50Hz - 220**

Version - code