



SD2000

SDR21DGXFPKG/US-100



Flow sensors

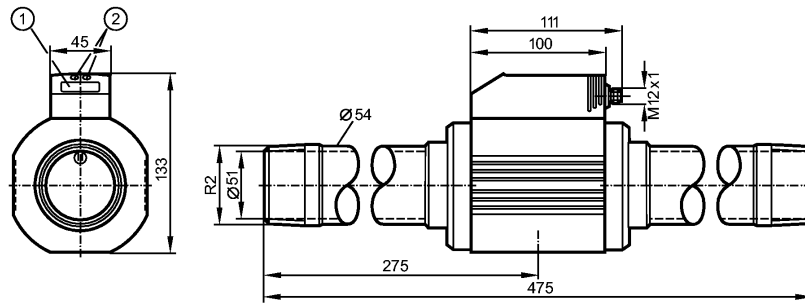

- 1: 4-digit alphanumeric display
- 2: Programming buttons



Product characteristics

Compressed air meter
Quick disconnect
Process connection: R2 (DN50)
Function programmable
2 outputs
OUT1: flow monitoring (binary), quantity meter (pulse), preset counter (binary)
OUT2: flow or temperature monitoring (analogue or binary)
flow monitoring
Display range
0...840 Nm ³ /h
Measuring range
2.3 (3)...700 Nm ³ /h *)
Temperature monitoring
Display range
-12...72 °C

Application

Application	Compressed air Air quality(ISO 8573-1): Class 141 (measuring error: see below, value A) Class 344 (measuring error: see below, value B)
Pressure rating [bar]	16
Medium temperature [°C]	0...60

Electrical data

Electrical design	DC PNP
Operating voltage [V]	18...30 DC ¹⁾
Current consumption [mA]	< 110
Protection class	III
Reverse polarity protection	yes

Outputs

Output function	OUT1: normally open / closed programmable or pulse OUT2: normally open / closed programmable or analog (4...20 mA scaleable)
Current rating [mA]	2 x 250
Voltage drop [V]	< 2
Short-circuit protection	yes (non-latching)



SD2000

SDR21DGXFPKG/US-100



Flow sensors

Overload protection	yes
Analog output	4...20 mA
Max. load [Ω]	< 500
Pulse output	consumed quantity meter

Measuring / setting range

Flow monitoring			
Measuring range	2.3 (3)...700 *) Nm ³ /h	0.039 (0.04)...11.66 *) Nm ³ /min	0.3...95.2 Nm/s
Display range	0...840 Nm ³ /h	0.00...13.99 Nm ³ /min	0.0...114.2 Nm/s
Set point, SP	5...700 Nm ³ /h	0.09...11.66 Nm ³ /min	0.7...95.2 Nm/s
Reset point, rP	2...697 Nm ³ /h	0.04...11.61 Nm ³ /min	0.3...94.8 Nm/s
Analog start point, ASP	0...525 Nm ³ /h	0.00...8.75 Nm ³ /min	0.0...71.4 Nm/s
Analog end point, AEP	175...700 Nm ³ /h	2.91...11.66 Nm ³ /min	23.8...95.2 Nm/s
in steps of	1 Nm ³ /h	0.01 Nm ³ /min	0.1 Nm/s
Volumetric flow quantity monitoring			
Pulse value	0.010...4000000 m ³		
in steps of	0.010 m ³		
Pulse length [s]	≥ 0.021 / ≤ 2		
Temperature monitoring			
Measuring range [°C]	0...60		
Display range [°C]	-12...72		

Accuracy / deviations

Flow monitoring	
Accuracy (within measuring range)	A): ± (3% MW + 0.3% MEW) / B): ± (6% MW + 0.6% MEW) ***)
Repeatability[% of the measured value]	± 1.5
Temperature monitoring	
Accuracy [K]	± 2 **)

Reaction times

Power-on delay time [s]	1
Flow monitoring	
Response time [s]	< 0.1 (dAP = 0)
Damping, dAP [s]	0 - 0.2 - 0.4 - 0.6 - 0.8 - 1

Software / programming

Programming options	hysteresis / window function; N.O. / N.C; current / pulse output; display can be rotated / deactivated; display unit, totalizer
---------------------	---

Interfaces

IO-Link Device	
Transfer type	COM2 (38.4 kBaud)
IO-Link revision	1.1
SDCI standard	IEC 61131-9 CDV
IO-Link Device ID	270 d / 00 01 0E h
Profiles	no profile
SIO mode	yes
Required master port class	A
Process data analogue	3
Process data binary	2



SD2000

SDR21DGXFPKG/US-100



Flow sensors

Min. process cycle time	[ms]	4.1 ms
-------------------------	------	--------

Environment

Ambient temperature	[°C]	0...60
Storage temperature	[°C]	-20...85
Max. relative air humidity	[%]	90
Protection		IP 65

Tests / approvals

Pressure equipment directive	article 3, section 3 - sound engineering practice	
EMC	DIN EN 61000-6-2 DIN EN 61000-6-3	
Vibration resistance	DIN EN 68000-2-6:	5 g (55...2000 Hz)
MTTF	[Years]	227

Mechanical data

Process connection	R2 (DN50)	
Materials (wetted parts)	stainless steel (304S15): FKM; ceramics: glass passivated; PEEK GF30; polyester; aluminum	
Housing materials	PBT-GF 20; NBR; PC (polycarbonate); stainless steel (304S15); PTFE; brass coated; FKM; aluminum powder-coated	
Weight	[kg]	4.35

Displays / operating elements

Display	Display unit 5 x LED green (Nm ³ /min, Nm ³ /h, Nm/s, Nm ³ , °C) Function display 1 x LED green Switching status 2 x LED yellow Measured values 4-digit alphanumeric display Programming 4-digit alphanumeric display
---------	--

Electrical connection

Connection	M12 connector
------------	---------------

Wiring

- OUT1/IO-Link: 3 selection options
- switching output flow rate monitoring
 - pulse output quantity meter
 - signal output preset counter
- OUT2/InD: 5 selection options
- switching output flow rate monitoring
 - switching output temperature monitoring
 - analogue output flow rate
 - analogue output temperature
 - input signal counter reset

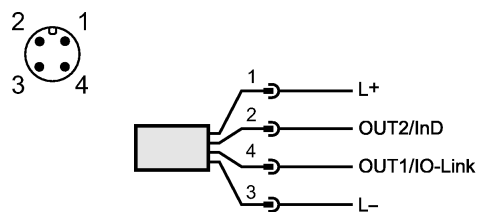

Remarks

Remarks	1) to EN50178, SELV, PELV *) in brackets: displayed value **) medium flow in the limit area of the flow measurement range ***) under conditions acc. to DIN ISO 2533 and when installed in DN50 pipes MW = measured value MEW = final value of the measuring range Measuring, display and setting ranges refer to standard volume flow according to DIN ISO 2533. For information about installation and operation please see the operating instructions.
---------	---

Pack quantity	[piece]	1
---------------	---------	---