



SDS180

Sectional directional control valve

Features

Simple, compact and heavy duty designed sectional valve from 1 to 12 sections for open and closed centre hydraulic systems.

- Fitted with a main pressure relief valve and a load check valve on every working section
- Available with parallel, tandem or series circuit.
- Optional carry-over port.
- A wide range of antishock+anticavitation port valves.
- Intermediate sections for several types of circuit.
- Available manual, pneumatic, electrohydraulic, proportional hydraulic, spool control kits.
- Diameter 20 mm (*0.79 in*) interchangeable spools.

Additional information

This catalogue shows the product in the most standard configurations.
Please contact our Sales Dpt. for more detailed information or special requests.

WARNING!

All specifications of this catalogue refer to the standard product at this date.
Walvoil, oriented to a continuous improvement, reserves the right to discontinue, modify or revise the specifications, without notice.

WALVOIL IS NOT RESPONSIBLE FOR ANY DAMAGE CAUSED BY AN INCORRECT USE OF THE PRODUCT.

8th edition June 2015

SDS180

- Valve general informations
 - Working conditions page 4
 - Standard threads page 4
 - Dimensional data page 5
 - Performance data page 5
 - Hydraulic circuit page 6
 - Complete sections ordering codes page 8
 - Configuration with SDS180 and SDS150 valves coupling together ordering codes page 10
- Inlet section
 - Parts ordering codes page 11
 - Dimensional data and hydraulic circuit page 12
 - Inlet relief options. page 13
- Inlet section for special application
 - Configuration with rotary commutator. page 16
 - Configuration with electric commutator page 18
 - Configuration with flow cut-out. page 20
 - Configuration with priority valve page 22
 - Conf. with unloader operation spool type page 24
- Working section
 - Parts ordering codes (mechanical control) page 26
 - Parts ordering codes (prop. hydraulic control) page 30
 - Dimensional data and hydraulic circuit page 32
 - Spools. page 34
 - "A" side spool positioners. page 36
 - "B" side options page 44
 - Complete controls. page 47
 - Port valves. page 51
- Intermediate section
 - CS1 mid return manifold section. page 58
 - CS3 mid return manifold section. page 59
 - EI service relief valve section page 60
- Outlet section
 - Parts ordering codes page 61
 - Dimensional data and hydraulic circuit page 61

Working conditions

This catalogue shows technical specifications and diagrams measured with mineral oil of 46mm²/s (46 cSt) viscosity at 40°C (104°F) temperature.

Nominal flow rating		160 l/min	42 US gpm
	for series circuit	140 l/min	37 US gpm
Max pressure ⁽¹⁾		315 bar	4600 psi
	for series circuit	250 bar	3600 psi
Back pressure (max.)	outlet port T	25 bar	360 psi
Internal leakage (standard) A(B)⇒T	Δp = 100 bar (1450 psi)	5 cm ³ /min	0.30 in ³ /min
Fluid		Mineral based oil	
Fluid temperature	with NBR (BUNA-N) seals	from -20°C to 80°C	from -4°F to 176°F
	with FPM (VITON) seals	from -20°C to 100°C	from -4°F to 212°F
Viscosity	operating range	from 15 to 75 mm ² /s	from 15 to 75 cSt
	min.	12 mm ² /s	12 cSt
	max.	400 mm ² /s	400 cSt
Max. contamination level		-/19/16 - ISO 4406	NAS 1638 - class 10
Ambient temperature for working conditions	with mechanical devices	from -40°C to 60°C	from -40°F to 140°F
	with pneumatic and hydraulic devices	from -30°C to 80°C	from -22°F to 140°F
	with electric devices	from -20°C to 50°C	from -4°F to 122°F

NOTE - ⁽¹⁾ Intermittent pressure at max. 250,000 cycles with specific internal testing.

Standard threads

REFERENCE STANDARD			
	BSP	UN-UNF	NPTF
THREAD ACCORDING TO	ISO 228/1	ISO 263	ANSI B1.20.3
	BS 2779	ANSI B1.1 unified	
CAVITY DIMENSION ACCORDING TO	ISO 1179-1	11926-1	
	SAE	J1926-1	J476a
	DIN 3852-2 shape X or Y		

PORTS THREADING		
MAIN PORTS	BSP	UN-UNF
Inlet P	G 3/4	1 5/16-12 (SAE 16)
Ports A and B	G 3/4	1 1/16-12 (SAE 12)
Outlet T and carry-over C	G 1	1 5/16-12 (SAE 16)
PILOT PORTS		
Hydraulic	G 1/4	9/16-18 (SAE 6)
Pneumatic	NPTF 1/8-27	NPTF 1/8-27

Dimensional data

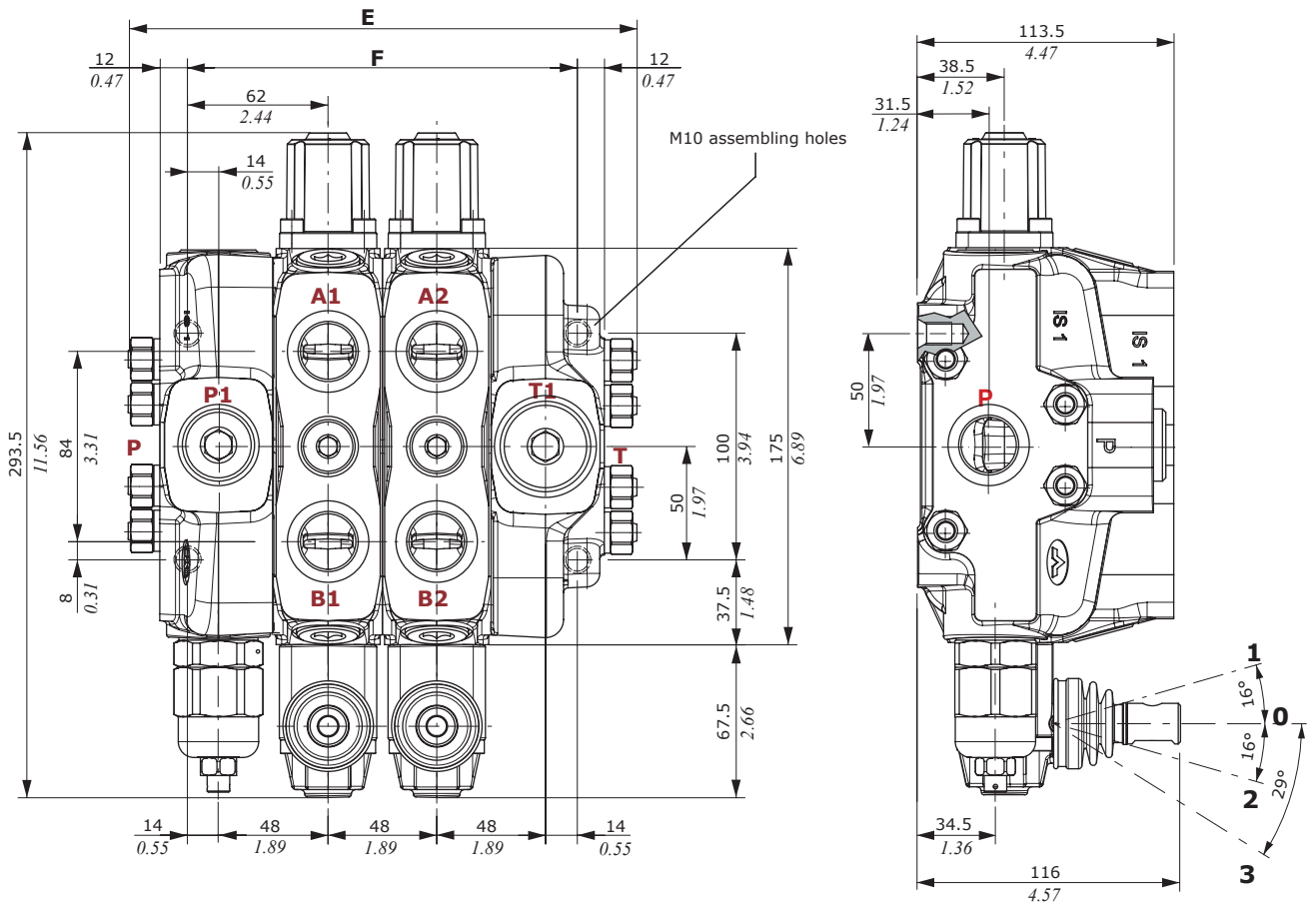

NOTE - Drawings and dimensions are referred to **BSP** thread configuration.

TYPE	E		F		Weight	
	mm	in	mm	in	Kg	lb
SDS180/1	176	6.93	124	4.88	13.8	30.42
SDS180/2	224	8.82	172	6.77	19.2	42.33
SDS180/3	272	10.71	220	8.66	24.6	54.23
SDS180/4	320	12.60	268	10.55	30	66.14
SDS180/5	368	14.49	316	12.44	35.4	78.04
SDS180/6	416	16.38	364	14.33	40.8	89.95

TYPE	E		F		Weight	
	mm	in	mm	in	Kg	lb
SDS180/7	464	18.27	412	16.22	46.2	101.85
SDS180/8	512	20.16	460	18.11	51.6	113.76
SDS180/9	560	22.05	508	20.00	57	125.66
SDS180/10	608	23.94	556	21.89	62.4	137.57
SDS180/11	656	25.83	604	23.78	67.8	149.47
SDS180/12	704	27.72	652	25.67	73.2	161.38

Performance data

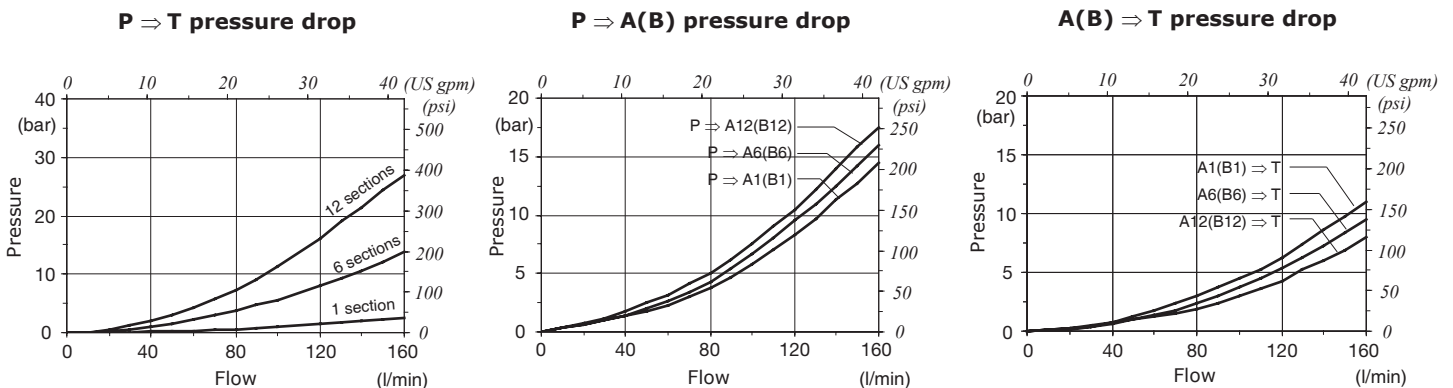

Hydraulic circuit

Parallel circuit

Standard configuration with open centre and side inlet and outlet.

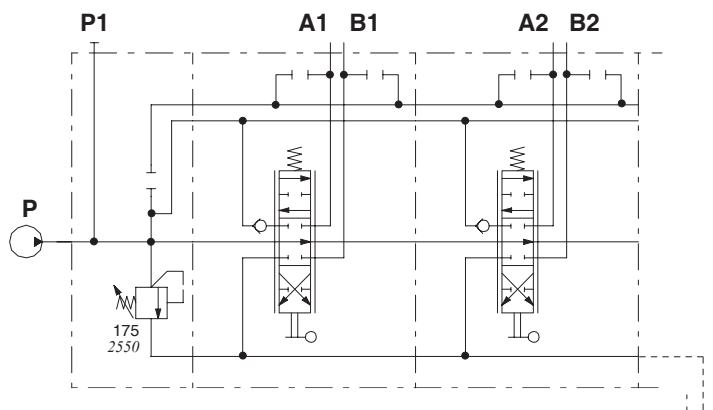

Description example:
SDS180/2/AC(YG3-120)/18L/18L/.....

Series-parallel (tandem) circuit

It needs a special working section kit.

Tandem section is fed from the free flow pressure line; it's excluded when an up stream section is operated.

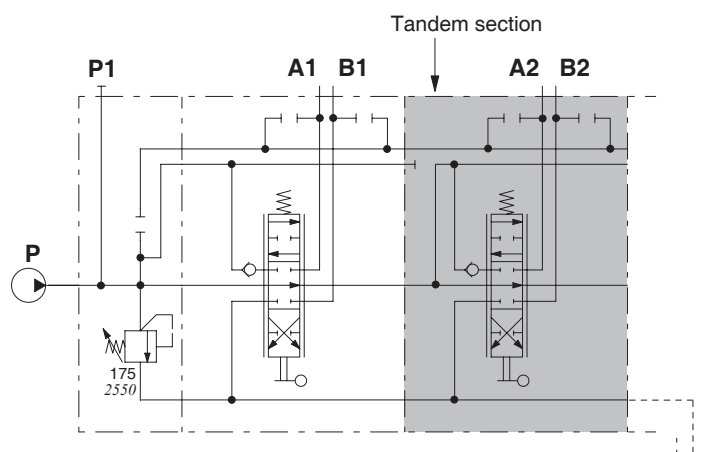

Description example:
SDS180/2/AC(YG3-120)/18L/**SP**-18L/.....

Series circuit

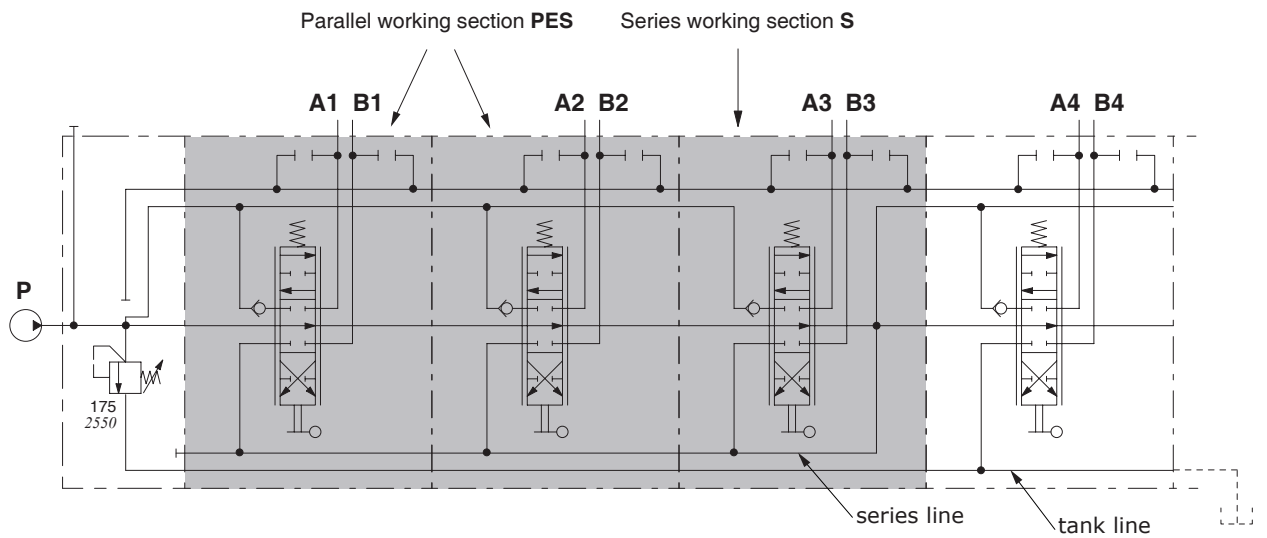

Description example:
 SDS180/4/AC(YG3-120)/PES-18L/PES-18L/S-18L/18L/.....

Right inlet directional valve

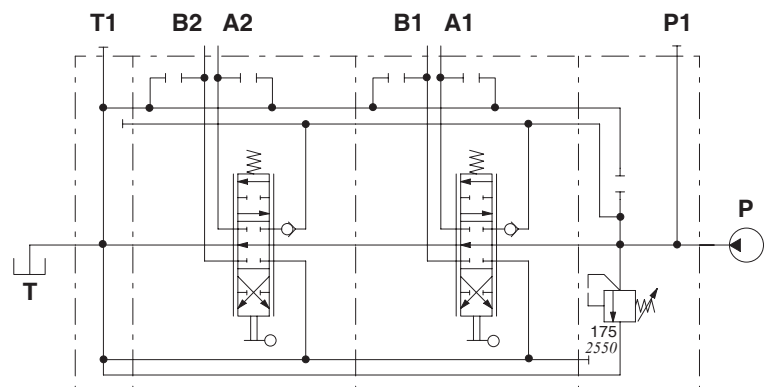
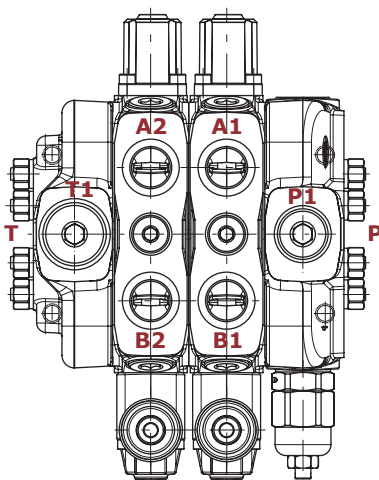

Description example:
 SDS180/2/BC(YG3-120)/18L/18L/RC

Complete sections ordering codes

Standard configuration with side inlet and outlet

SDS180 / 2 / AC(YG3-175) / 18L / EI1(YG3-180) / 18L / RC - STAF

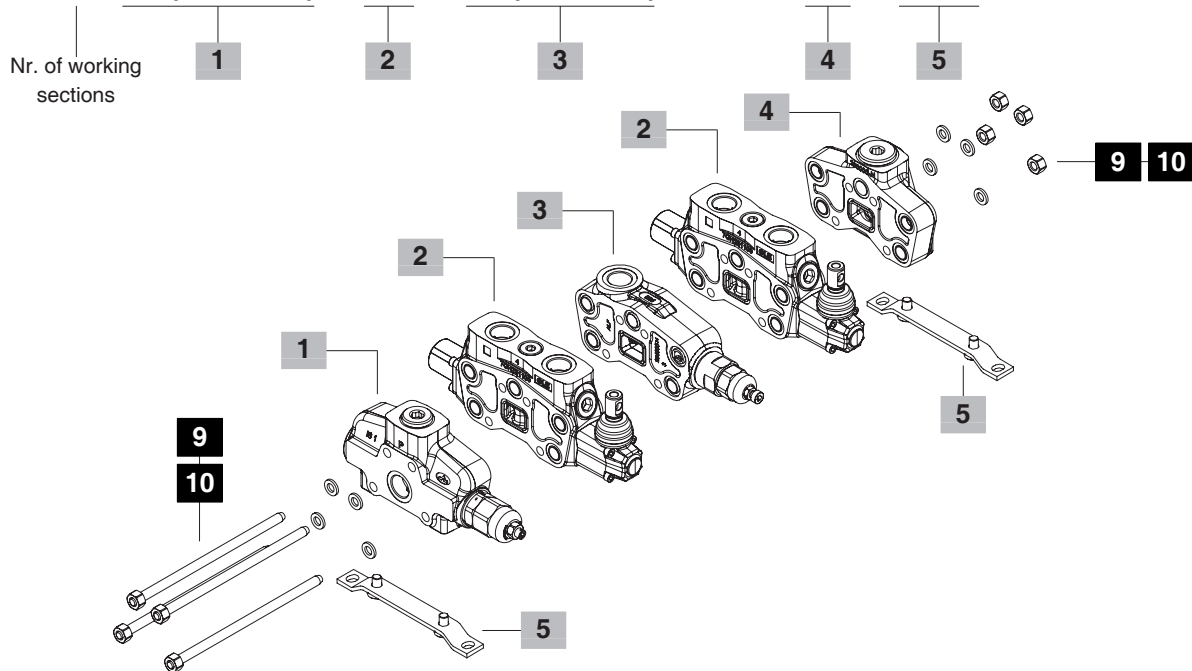

1 Inlet section * page 11

TYPE	CODE	DESCRIPTION
TYPE AC(YG3-175)	CODE 618201005	DESCRIPTION With direct pressure relief valve
TYPE AC(XG-120)	CODE 618201004	DESCRIPTION With pilot pressure relief valve
TYPE AC(SV)	CODE 618201006	DESCRIPTION Without pressure relief valve
TYPE AC(YG3-120)R2	CODE 618201007	DESCRIPTION With direct pressure relief valve and rotary commutator
TYPE AC(YG3-120)R2E	CODE 618201008	DESCRIPTION With direct pressure relief valve and 12VDC electric commutator
TYPE M(LSW-120)ELNW(NC)	CODE 618201009	DESCRIPTION With flow cut-out and LS pressure relief valve
TYPE ACD/VPD(LSZ-230/YG3-120)	CODE 618201018	DESCRIPTION With double stage pressure relief valve and priority valve
TYPE BCHW(LSW-250)ELNW(NO)-12VDC	CODE 618201029	DESCRIPTION With unloader operation spool type and LS pressure relief valve 12VDC

2 Working section * page 26

TYPE	CODE	DESCRIPTION
18L	618101003	Parallel circuit, prearranged for port valves, double acting spool with spring return, lever control
SP-18L	618105005	As previous with series-parallel (tandem) circuit
1IM8IM	618101004	As parallel circuit with proportional hydraulic control
S-18L	615111001	Series circuit, lever control

2 Working section (continued)* page 26

TYPE	CODE	DESCRIPTION
PES-18L	618101031	Parallel circuit, lever control to combine with series working section (see page 7)
RPHT-18L	618101069	Parallel circuit, prearranged for valves with fixed setting, double acting spool with spring return, lever control
RPHSP-18L	618101070	As previous with series-parallel (tandem) circuit
RQHT-18L	618101071	For parallel circuit without upper predisposition for port valves
RPHT-1IM8IM	618101072	As parallel circuit, prearranged for valves with fixed setting for proportional hydraulic control

3 Intermediate sections * page 60

TYPE	CODE	DESCRIPTION
EI1(YG3)	618401001	With direct pressure relief valve

4 Outlet section * page 61

TYPE	CODE	DESCRIPTION
RC	618301003	With side outlet
RD	618301002	With upper outlet
RE	618301001	With upper outlet and side carry-over sleeve
RK	618301004	With upper outlet, closed center
RV	618301009	With backpressure valve

5 Fixing brackets page 79

TYPE	CODE	DESCRIPTION
STAF	5STA125220	Brackets with assembling screws

NOTE (*) - Codes are referred to **BSP** thread.

Complete sections ordering codes

Configuration with 2 side inlets and mid return manifold

SDS180 / 2 / AC(YG3-120) / 18L / CS1 / ED-18L / BC(YG3-120) - STAF

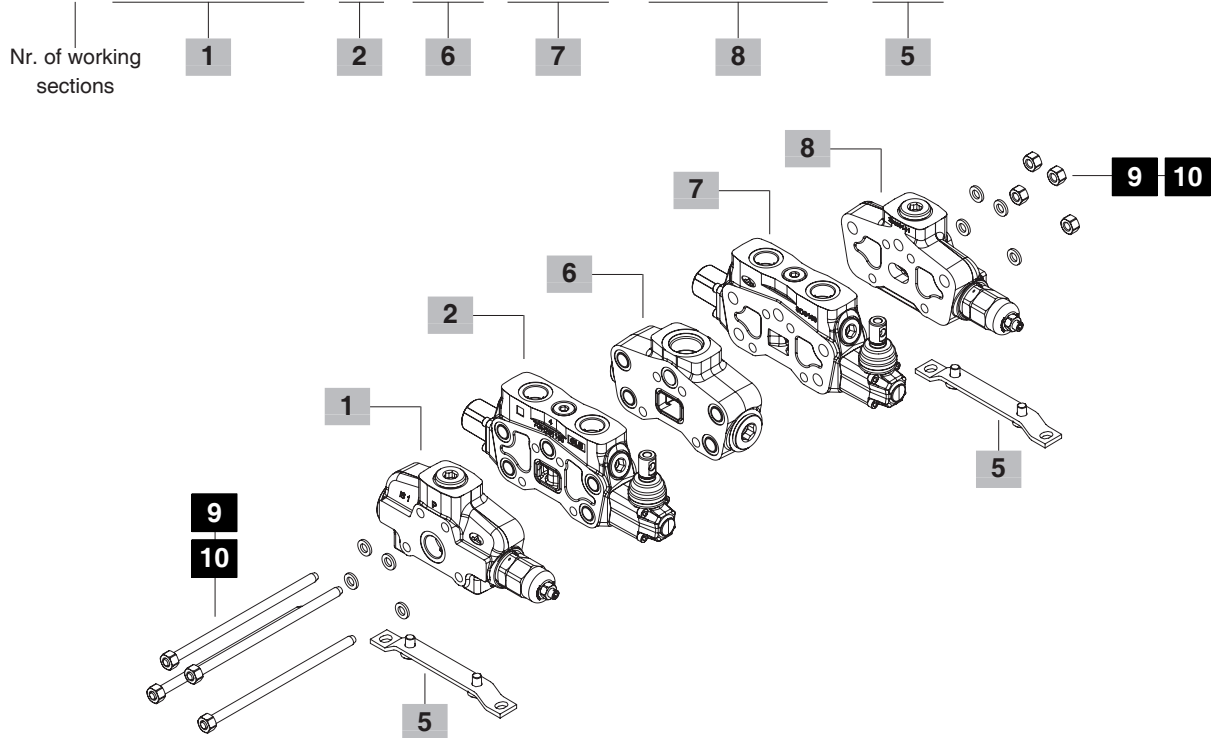

6 Return manifold * page 58

TYPE	CODE	DESCRIPTION
CS1	615401010	Mid return manifold

7 Right inlet working section *

TYPE	CODE	DESCRIPTION
P-ED-18L	618101041	Parallel circuit, prearranged for port valves, double acting spool with spring return, lever control
SP-ED-18L	618101043	As previous with series-parallel (tandem) circuit

8 Right inlet section *

TYPE	CODE	DESCRIPTION
BC(YG3-120)	618201025	Side inlet with direct press. relief valve
BC(XG-120)	618201026	Side inlet with pilot pressure relief valve
BC(SV)	618201027	Side inlet without pressure relief valve
BD(YG3-120)	618201028	Upper inlet with direct pressure relief valve

9 Assemb. kit without intermediate section

CODE	DESCRIPTION
5TIR110170	Tie rod kit for 1 working section directional valve
5TIR110218	Tie rod kit for 2 working sections directional valve
5TIR110266	Tie rod kit for 3 working sections directional valve
5TIR110316	Tie rod kit for 4 working sections directional valve
5TIR110368	Tie rod kit for 5 working sections directional valve
5TIR110410	Tie rod kit for 6 working sections directional valve
5TIR110458	Tie rod kit for 7 working sections directional valve
5TIR110506	Tie rod kit for 8 working sections directional valve
5TIR110554	Tie rod kit for 9 working sections directional valve
5TIR110602	Tie rod kit for 10 working sections directional valve
5TIR110650	Tie rod kit for 11 working sections directional valve
5TIR110698	Tie rod kit for 12 working sections directional valve

10 Assemb. kit with intermediate section

CODE	DESCRIPTION
5TIR110266	Tie rod kit for 2 working sections directional valve
5TIR110316	Tie rod kit for 3 working sections directional valve
5TIR110368	Tie rod kit for 4 working sections directional valve
5TIR110410	Tie rod kit for 5 working sections directional valve
5TIR110458	Tie rod kit for 6 working sections directional valve
5TIR110506	Tie rod kit for 7 working sections directional valve
5TIR110554	Tie rod kit for 8 working sections directional valve
5TIR110602	Tie rod kit for 9 working sections directional valve
5TIR110650	Tie rod kit for 10 working sections directional valve
5TIR110698	Tie rod kit for 11 working sections directional valve
5TIR110746	Tie rod kit for 12 working sections directional valve

NOTE (*) – Codes are referred to **BSP** thread.

Configuration with SDS180 and SDS150 valves coupling together ordering codes _____

SDS180/2/AC(YG3-120)/18L/18L / CS3 / 18L/18L/BC(YG3-120)/SDS150/2

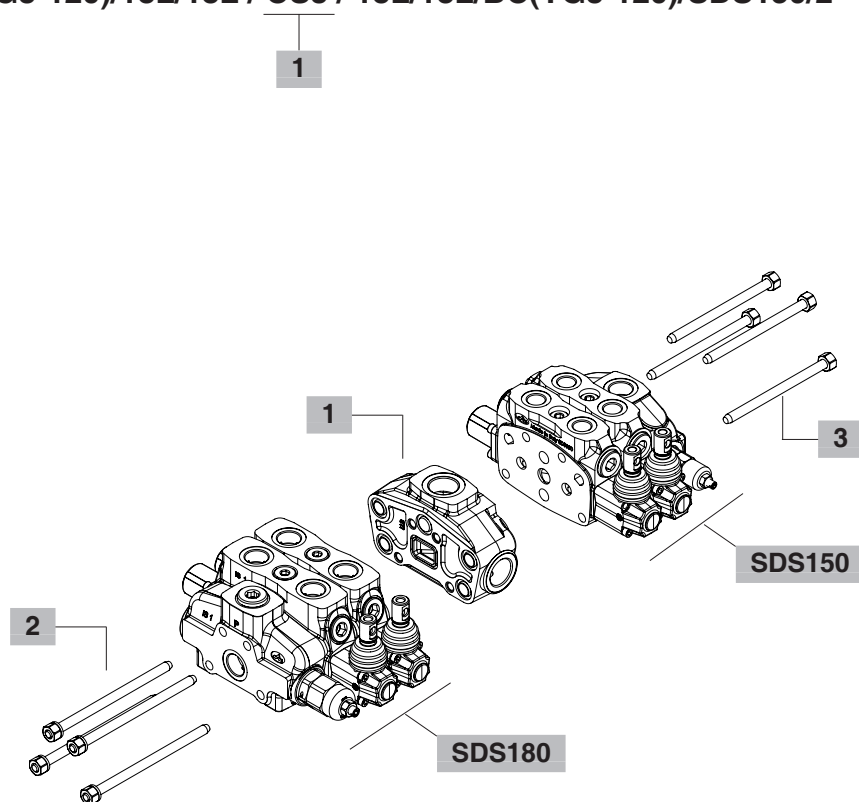

1 Return manifold *

TYPE	CODE	DESCRIPTION
CS3	615441010	Mid return manifold

2 Assembling kit for SDS180 valve side

CODE	DESCRIPTION
5TIR4161	Tie rod kit for 1 working section directional valve
5TIR4162	Tie rod kit for 2 working sections directional valve
5TIR4163	Tie rod kit for 3 working sections directional valve
5TIR4164	Tie rod kit for 4 working sections directional valve
5TIR4165	Tie rod kit for 5 working sections directional valve
5TIR4166	Tie rod kit for 6 working sections directional valve
5TIR4167	Tie rod kit for 7 working sections directional valve
5TIR4168	Tie rod kit for 8 working sections directional valve
5TIR4169	Tie rod kit for 9 working sections directional valve
5TIR416A	Tie rod kit for 10 working sections directional valve

3 Assembling kit for SDS150 valve side

CODE	DESCRIPTION
5TIR41501	Tie rod kit for 1 working section directional valve
5TIR41502	Tie rod kit for 2 working sections directional valve
5TIR41503	Tie rod kit for 3 working sections directional valve
5TIR41504	Tie rod kit for 4 working sections directional valve

NOTE (*) – Codes are referred to **BSP** thread.

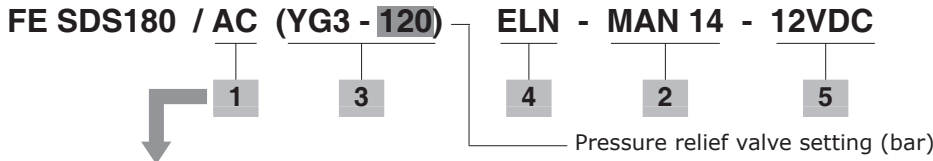

Available configurations

- AC:** with side inlet, for left inlet (standard) directional valve
- AD:** with upper inlet, for left inlet (standard) directional valve
- BC:** with side inlet, for right inlet directional valve
- BD:** with upper inlet, for right inlet directional valve

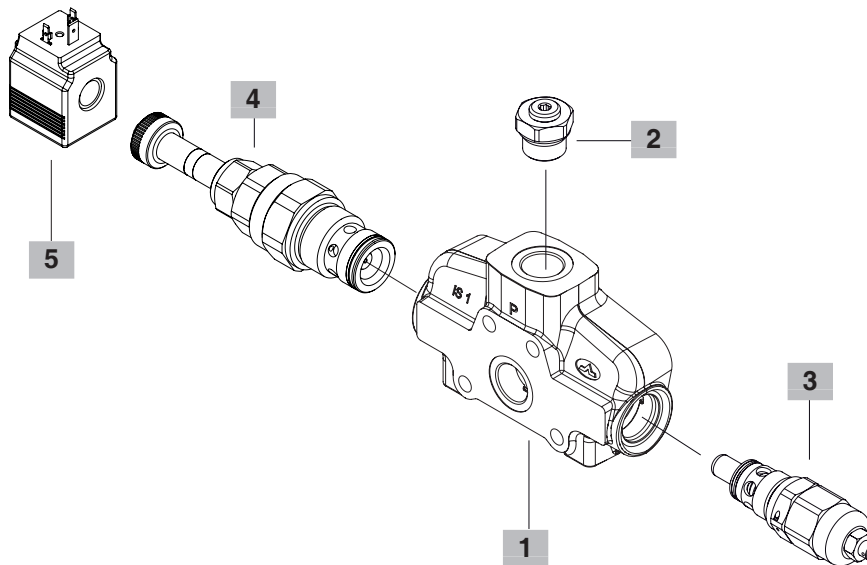

1 Inlet cover body * page 12

CODE: 3FIA118301-H
DESCRIPTION: Standard body

2 Parts *

TYPE	CODE	DESCRIPTION
-	3XTAP732200	G3/4 plug (omitted in description)
MAN18	5MAN632230	G1/8 Pressure gauge arrangement
MAN14	5MAN632231	G1/4 Pressure gauge arrangement

3 Inlet relief valve options page 13

Standard setting is referred to 10 l/min (2.6 US gpm).

SV	3XTAP535410	Relief valve blanking plug
VMP20/1 pilot operated pressure relief valve type X (XG-120)	X007211120	Range 60-315 bar (870-4570 psi) standard setting 120 bar (1750 psi)
(XGN-120)	XCAR120313	As previous without filter
VMD20/1 direct pressure relief valve type Y (standard) (YG2-80)	3XCAR120212	Range 63-125 bar (900-1800 psi) standard setting 80 bar (1150 psi)
(YG3-175)	3XCAR120213	Range 100-200 bar (1450-2900 psi) standard setting 175 bar (2500 psi)
(YG4-250)	3XCAR120214	Range 160-320 bar (2300-4650 psi) standard setting 250 bar (3600 psi)
Double stage relief valve (pilot port SAE 8) (XGD-207-235)	1130040408	Setting 207 and 235 bar (3000 and 3400 psi)

4 Inlet valve options page 15

TYPE	CODE	DESCRIPTION
-	3XTAP535410	Relief valve blanking plug (omitted in description)
F	5KIT420200	Inlet anti-cavitation valve
L	3XCAR420300	Hydraulic operated
Solenoid operated unloader valve		
ELN	YEF08002000	Without emergency
ELP	YEF08002002	Push-button emergency
ELV	YEF08002003	Screw type emergency
ELT	YEF08002004	Push and twist type with detent emergency

5 Coils page 76

TYPE	CODE	DESCRIPTION
12VDC	4SLE001200	BER type, 12 VDC, ISO4400 connector

For complete available coils list see page 76

NOTE (*) – Codes are referred to **BSP** thread.

Dimensional data and hydraulic circuit

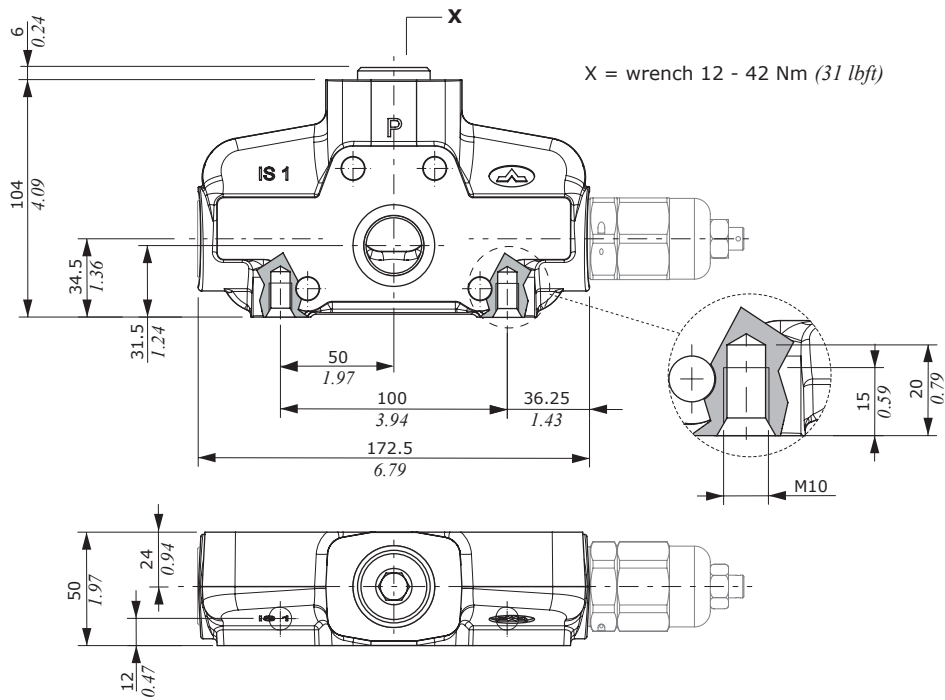

For left inlet directional valve, side port

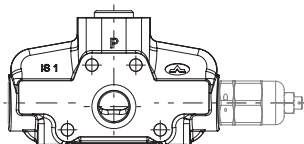
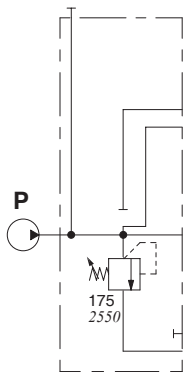

Description example:
AC(YG3-175)

For left inlet directional valve, upper port

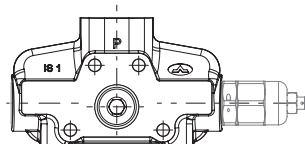
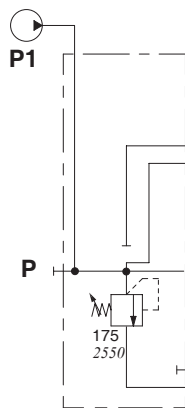

Description example:
AD(YG3-175)

For right inlet directional valve, side port

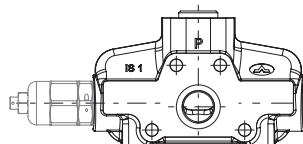
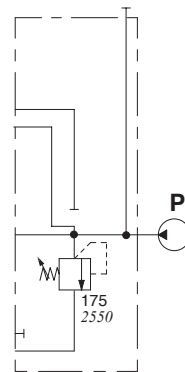

Description example:
BC(YG3-175)

For right inlet directional valve, upper port

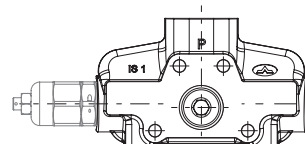
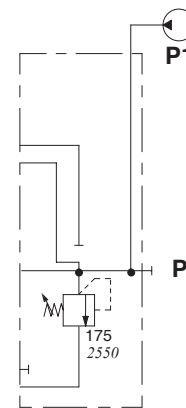

Description example:
BD(YG3-175)

Direct overpressure relief valve

Description example: **Y G 3 - 120**



- X = wrench 17 - 24 Nm (17.7 lbf^t)
- Y = allen wrench 5
- W = wrench 36 - 42 Nm (31 lbf^t)

Configuration type **G**: adjustable with screw

Configuration type **H**: valve set and locked

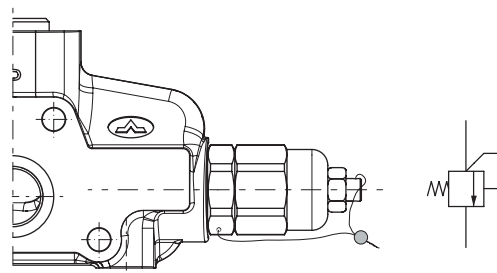
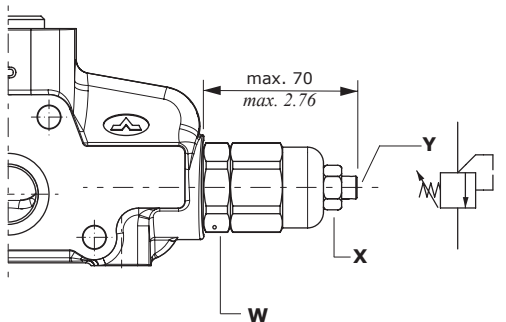

YG2 valve setting range

From 63 to 125 bar (from 900 to 1800 psi)

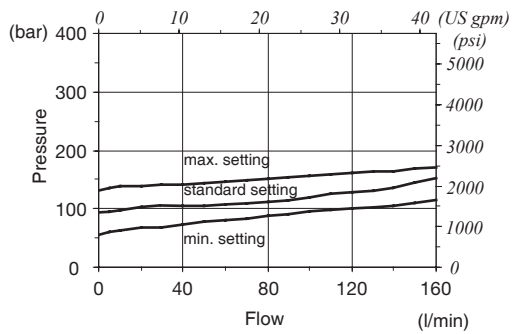

YG3 valve setting range

From 100 to 200 bar (from 1450 to 2900 psi)

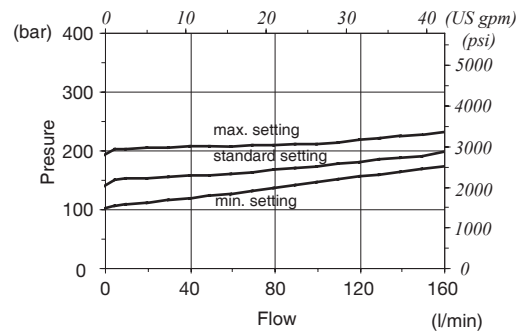

YG4 valve setting range

From 160 to 320 bar (from 2300 to 4650 psi)

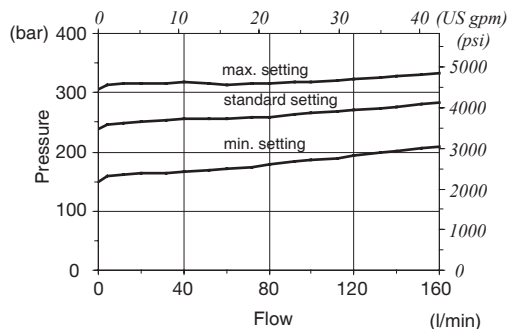

Inlet valve options

Pilot operated overpressure relief valve

Description example: **X G N - 120**

Configuration ——— Valve setting (bar)
 ——— Without filter

Configuration type **G**: adjustable with screw

X = wrench 13 - 24 Nm (17.7 lbf)

Y = allen wrench 5

W = wrench 36 - 42 Nm (31 lbf)

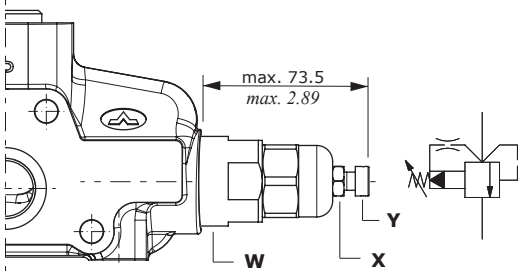

Configuration type **Z**: valve set and locked with tamper proof cap

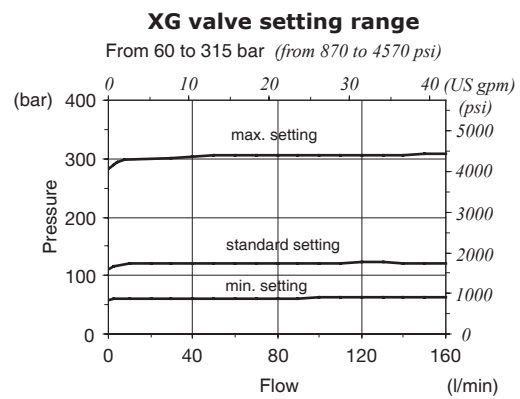
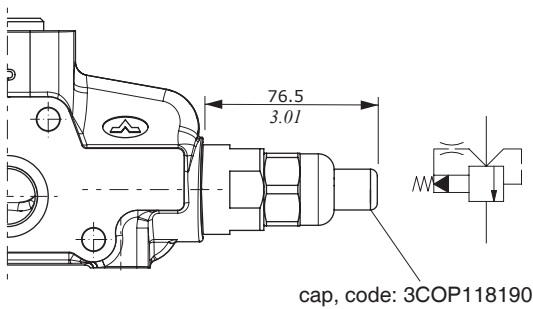

Double stage relief valve

Description example: **X G D - 207-235**

Valve setting (bar)

Z = wrench 36 - 42 Nm (31 lbf)

Y = allen wrench 36

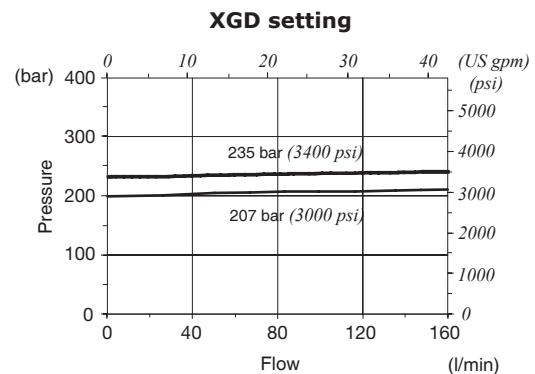
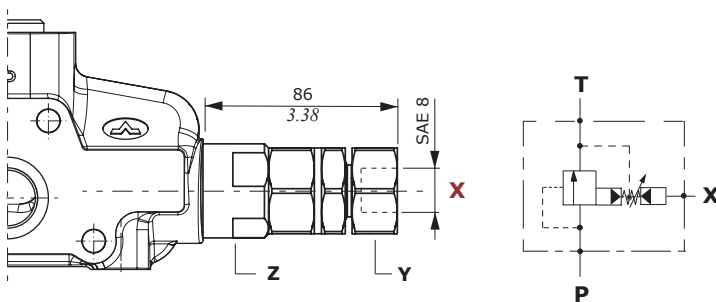

NOTE - valve available with SAE pilot; for executions with different thread contact the Sales Dpt.

Unloader valves

Description example: AC (YG3 - 120) **ELT - 12VDC**

Hydraulic operated valve: **L**
 Solenoid operated valve: **ELN** Feeding voltage:
ELP for solenoid operated
ELV
ELT

Solenoid operated

Emergency with push button and spring return; for detent position turn the button after press it.
WARNING: the manual override option is intended for emergency use, not for continuous duty operation.

Hydraulic operated

Y = wrench 36 - 42 Nm (31 lbf^t)

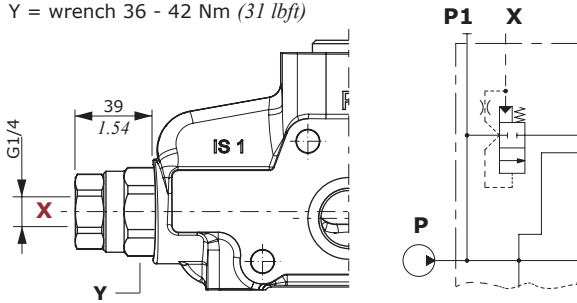

Y = wrench 36 - 42 Nm (31 lbf^t)

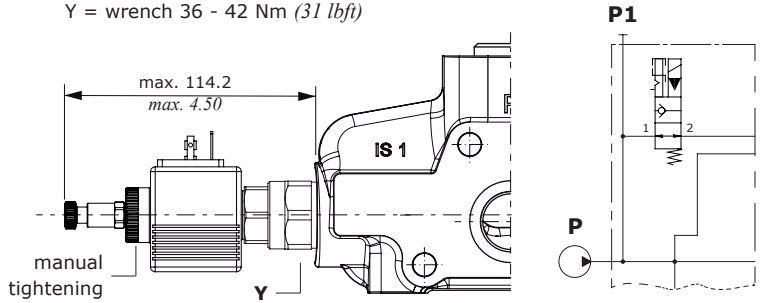

ELN: without emergency

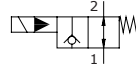

ELP: push button type

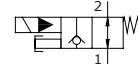

ELV: screw type

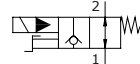

ELT: "push & twist" type

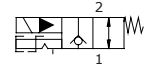

Pressure drop valve L type on SDS180/2

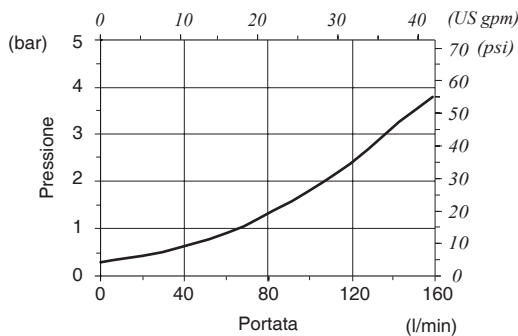

Valve L type features

Nominal flow 120 l/min (31.7 US gpm)
 Internal leakage 10 cm³/min @ 100 bar
 (0.61 in³/min @ 1450 psi)

Pressure drop valve EL type on SDS180/2

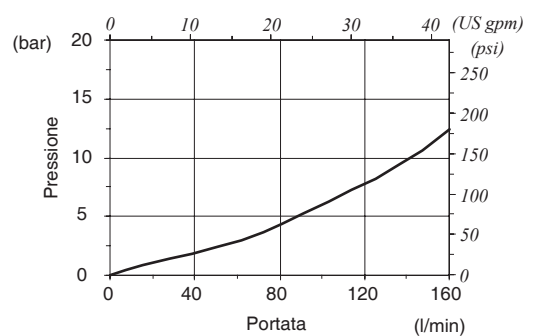

Valve EL type features

Nominal flow 40 l/min (10.6 US gpm)
 Max. pressure. 350 bar (5100 psi)
 Internal leakage 50 cm³/min @ 210 bar
 (3.05 in³/min @ 3050 psi)

For coil **BER** see page 77

Anti-cavitation valve

Description example: AC (YG3 - 120) **F**

X = wrench 32 - 9.8 Nm (7.23 lbf^t)

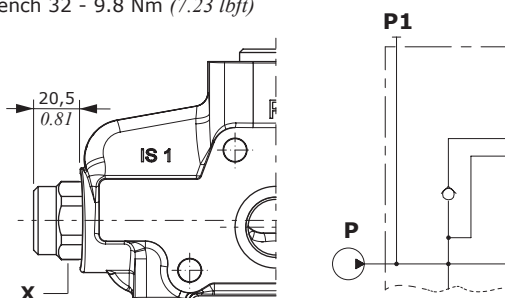

Pressure drop

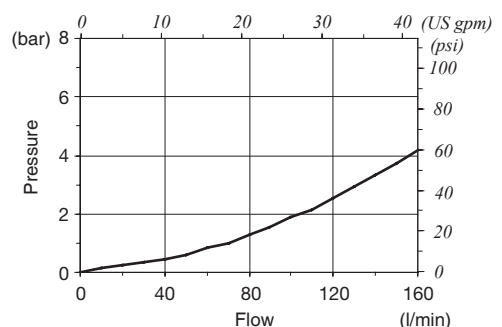

Configuration with rotary commutator

FE SDS180 / AC ELN - 12VDC - R2

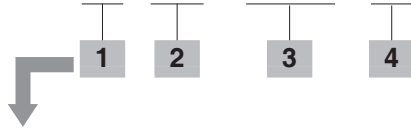

Available configurations

- AC:** with side inlet, for left inlet (standard) directional valve
- AD:** with upper inlet, for left inlet (standard) directional valve
- BC:** with side inlet, for right inlet directional valve
- BD:** with upper inlet, for right inlet directional valve

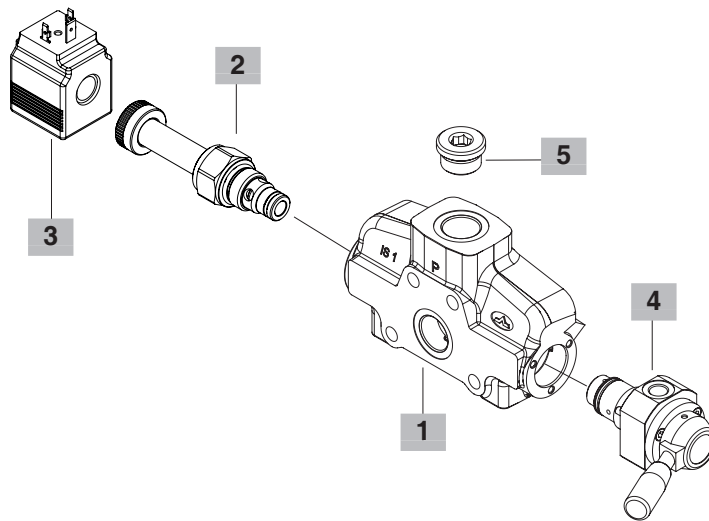

1 Inlet cover body * page 17

CODE: 3FIA118311-H
DESCRIPTION: Predisposition for rotary commutator

2 Inlet valve options page 13

Standard setting is referred to 10 l/min (2.6 US gpm) flow.

INLET RELIEF OPTIONS

TYPE	CODE	DESCRIPTION
SV	3XTAP535410	Relief valve blanking plug
VMP20/1 pilot operated pressure relief valve type X		
(XG-120)	X007211120	Range 60-250 bar (900-3600 psi) standard setting 120 bar (1750 psi)
(XGN-120)	XCAR120313	As previous without filter
VMD20/1 direct pressure relief valve type Y (standard)		
(YG2-80)	3XCAR120212	Range 63-125 bar (900-1800 psi) standard setting 80 bar (1150 psi)
(YG3-175)	3XCAR120213	Range 100-200 bar (1450-2900 psi) standard setting 175 bar (2500 psi)
(YG4-250)	3XCAR120214	Range 160-320 bar (2300-4650 psi) standard setting 250 bar (3600 psi)

Double stage relief valve (pilot port SAE 8)

(XGD-207-235) 1130040408 Setting 207 and 235 bar (3000 and 3400 psi)

INLET VALVE OPTIONS

F	5KIT420200	Inlet anti-cavitation valve
L	3XCAR420300	Hydraulic operated unloader valve

Solenoid operated unloader valve

ELN	YEF08002000	Without emergency
ELP	YEF08002002	Push-button emergency
ELV	YEF08002003	Screw type emergency
ELT	YEF08002004	Push and twist type with detent emergency

3 Coils page 76

TYPE	CODE	DESCRIPTION
12VDC	4SLE001200	BER type, 12 VDC, ISO4400 connector For complete available coils list see page 76

4 Commutator *

TYPE	CODE	DESCRIPTION
R2	5COM416203	Rotary commutator

5 Parts *

CODE	DESCRIPTION
3XTAP732200	G3/4 Plug

NOTE (*) – Codes are referred to **BSP** thread.

Configuration with rotary commutator

Dimensional data and hydraulic circuit

Drawing and circuit are referred to left inlet directional valve.

Z = wrench 17 - 24 Nm (17.7 lbf^t)

Y = allen wrench 5

W = wrench 36 - 42 Nm (31 lbf^t)

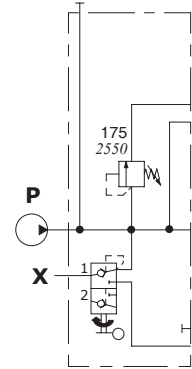
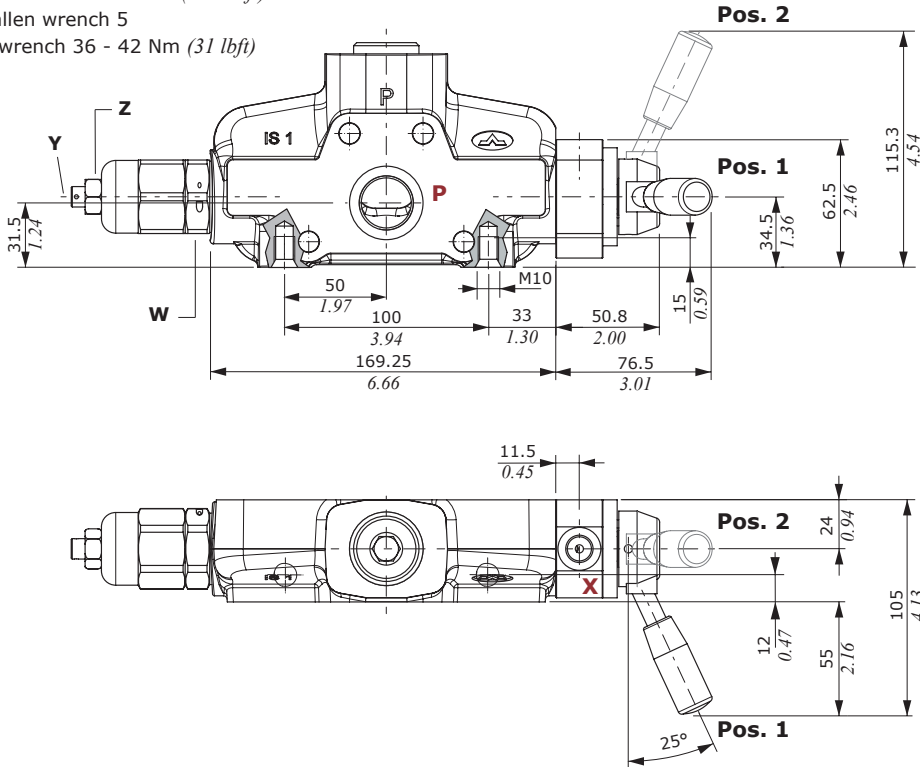

Rotary commutator features

Max. pressure: 210 bar (3050 psi)

Internal leakage: 3 cm³/min @ 100 bar
(0.18 in³/min @ 1450 psi)

Configuration with electric commutator

FE SDS180 / AC (YG3 - 120) R2E - 12VDC

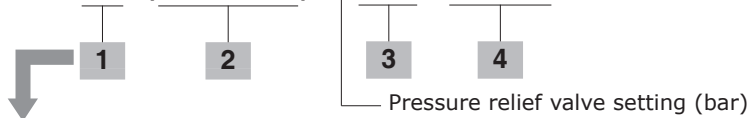

Available configurations

- AC: with side inlet, for left inlet (standard) directional valve
- AD: with upper inlet, for left inlet (standard) directional valve
- BC: with side inlet, for right inlet directional valve
- BD: with upper inlet, for right inlet directional valve

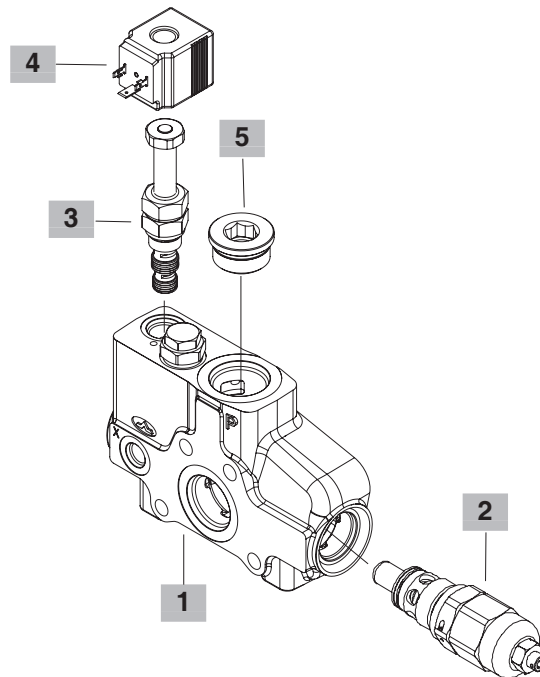

1 Inlet cover body * page 19

CODE: 5FIA118361

DESCRIPTION: Predisposition for electric commutator

2 Inlet valve options page 13

Standard setting is referred to 10 l/min (2.6 US gpm) flow.

TYPE	CODE	DESCRIPTION
SV	3XTAP535410	Relief valve blanking plug
F	5KIT420200	Inlet anti-cavitation valve
L	3XCAR420300	Hydraulic operated unloader valve

VMP20/1 pilot operated pressure relief valve type X (XG-120)
 X007211120 Range 60-250 bar (900-3600 psi) standard setting 120 bar (1750 psi)

(XGN-120) XCAR120313 As previous without filter

VMD20/1 direct pressure relief valve type Y (standard) (YG2-80)
 3XCAR120212 Range 63-125 bar (900-1800 psi) standard setting 80 bar (1150 psi)

(YG3-175) 3XCAR120213 Range 100-200 bar (1450-2900 psi) standard setting 175 bar (2500 psi)

(YG4-250) 3XCAR120214 Range 160-320 bar (2300-4650 psi) standard setting 250 bar (3600 psi)

Double stage relief valve (pilot port SAE 8) (XGD-207-235) 1130040408 Setting 207 and 235 bar (3000 and 3400 psi)

2 Inlet valve options (continued) page 15

Solenoid operated unloader valve

TYPE	CODE	DESCRIPTION
ELN	YEF08002000	Without emergency
ELP	YEF08002002	Push-button emergency
ELV	YEF08002003	Screw type emergency
ELT	YEF08002004	Push and twist type with detent emerg.

3 Electric commutator *

TYPE	CODE	DESCRIPTION
R2E	0EJ08002048	Electric commutator, ISO4400 connector

For complete available coils list see page 77

4 Coils Page 76

TYPE	CODE	DESCRIPTION
12VDC	4SLE001200	BER type, 12VDC, ISO4400 connector

For complete available coils list see page 76

5 Parts *

CODE	DESCRIPTION
3XTAP732200	G3/4 Plug

NOTE (*) - Codes are referred to **BSP** thread.

Configuration with electric commutator

Dimensional data and hydraulic circuit

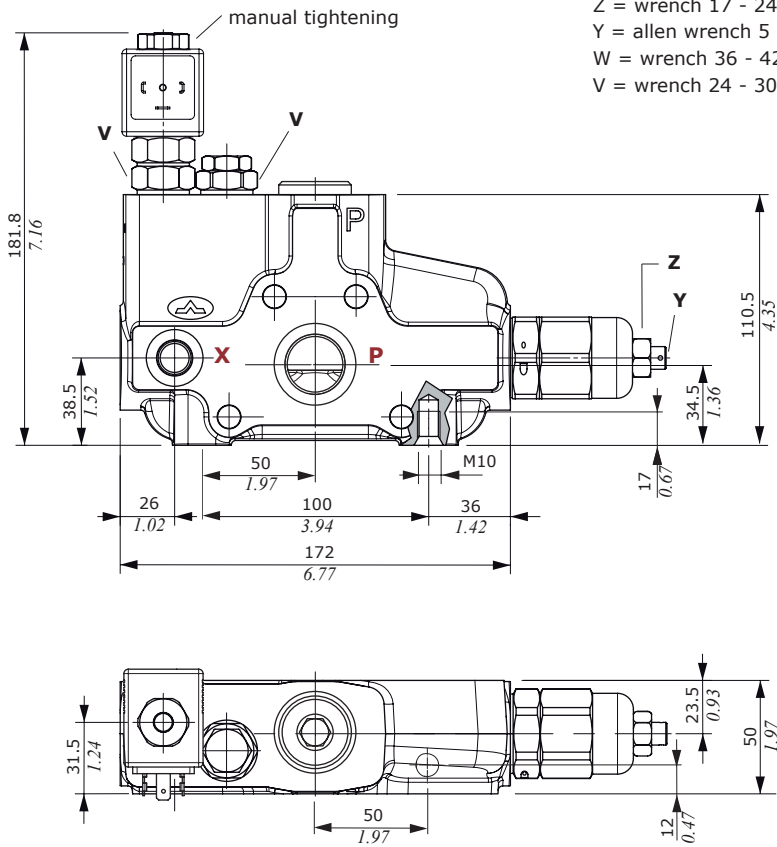

- Z = wrench 17 - 24 Nm (17.7 lbft)
- Y = allen wrench 5
- W = wrench 36 - 42 Nm (31 lbft)
- V = wrench 24 - 30 Nm (22.1 lbft)

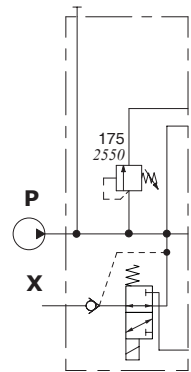

Electric commutator features

- Max. pressure : 250 bar (3600 psi)
- Nominal flow : 25 l/min (6.6 US gpm)
- Internal leakage : 40 cm³/min @ 210 bar
(2.44 in³/min @ 3050 psi)

For coil **BER** see page 77

Configuration with flow cut-out

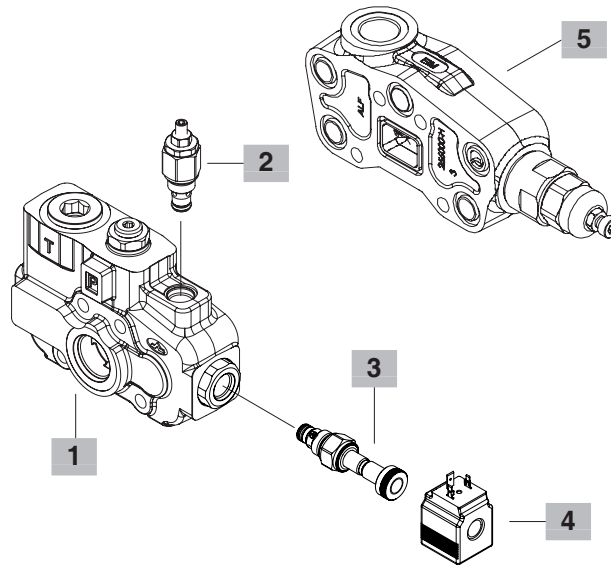
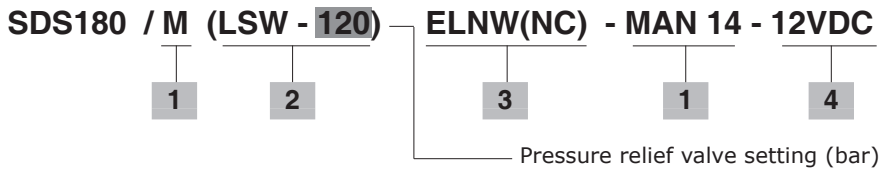

1 Inlet cover body * page 21

CODE: 5FIA118372
DESCRIPTION: With flow cut-out

2 Inlet valve options page 21

Standard setting is referred to 10 l/min (2.6 US gpm) flow.

TYPE	CODE	DESCRIPTION
SV	XTAP525320	Relief valve blanking plug
Main relief valve		
LSW(G2)	5KIT118110	Range 5-50 bar (72-720 psi) standard setting 30 bar (400 psi)
LSW(G3)	5KIT118111	Range 50-200 bar (720-2900 psi) standard setting 150 bar (2150 psi)
LSW(G4)	5KIT118112	Range 180-315 bar (2600-4550 psi) standard setting 250 bar (3600 psi)

3 Unloader valve options page 21

TYPE	CODE	DESCRIPTION
ELNW(NO)	0EF08002000	Without manual emergency, NO circuit
ELNW(NC)	0EF08002001	Without manual emergency, NC circuit
ELTW(NO)	0EF08002004	"Push&twist" manual emergency, NO circuit
ELPW(NO)	0EF08002002	Push-button manual emergency, NO circuit
ELVW(NO)	0EF08002003	Screw type manual emergency, NO circuit

4 Coils page 76

TYPE	CODE	DESCRIPTION
12VDC	4SLE001200	BER type, 12VDC, ISO4400 connector For complete available coils list see page 76

5 Intermediate section * page 60

TYPE	CODE	DESCRIPTION
EIM(XG-220)	618421001	intermediate section with pressure relief valve

NOTE: inlet cover with flow cut-out must be **always** combined with EIM intermediate section. (See page 60).

NOTE (*) – Codes are referred to **BSP** thread.

Configuration with flow cut-out

Dimensional data and hydraulic circuit

- X = wrench 12 - 42 Nm (31 lbf^t)
- Y = allen wrench 4
- W = wrench 6 - 24 Nm (17.7 lbf^t)
- Z = wrench 10 - 24 Nm (17.7 lbf^t)
- V = wrench 27 - 24 Nm (17.7 lbf^t)
- U = wrench 24 - 30 Nm (22.1 lbf^t)
- R = wrench 32 - 42 Nm (31 lbf^t)
- S = allen wrench 13

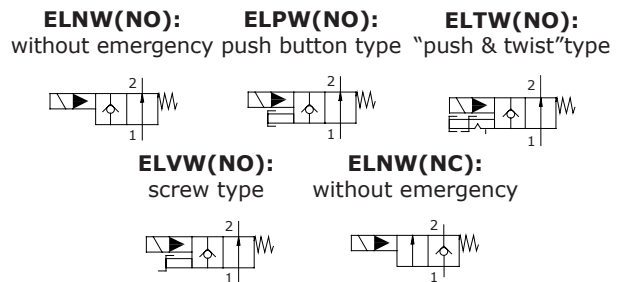
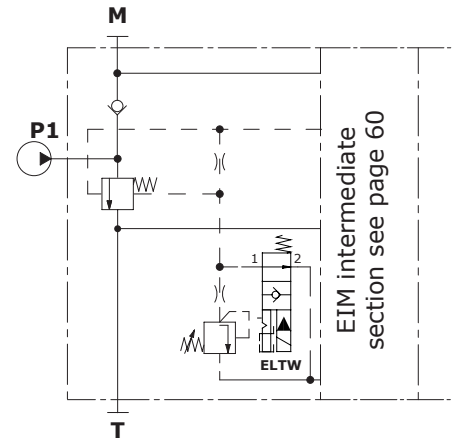
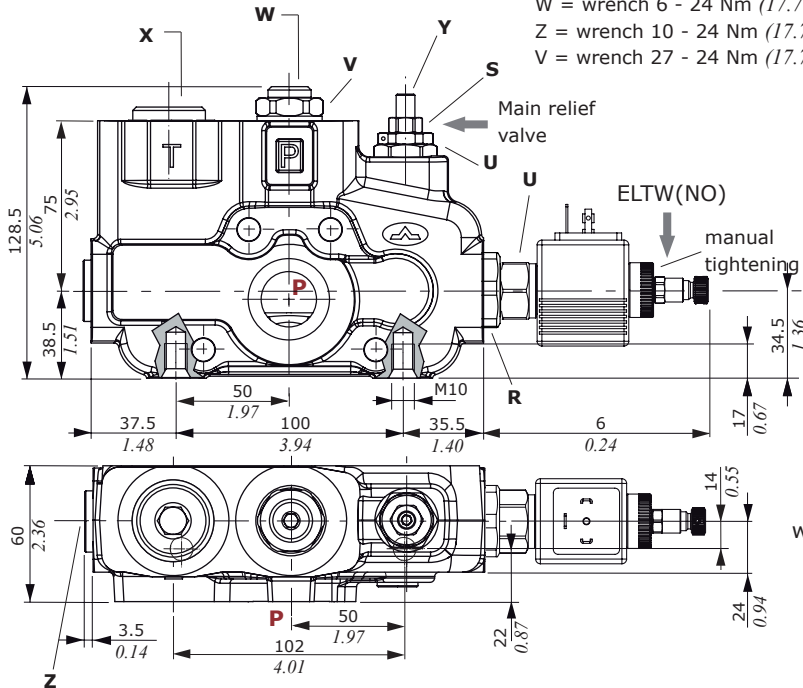

Valve diagrams

LSW(G2) main relief valve setting range

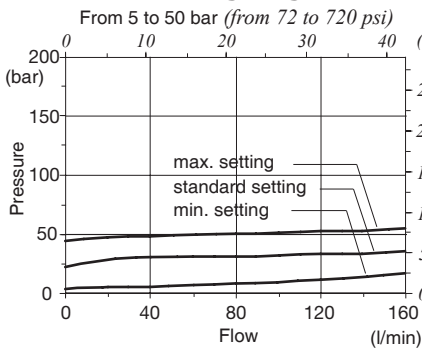

LSW(G3) main relief valve setting range

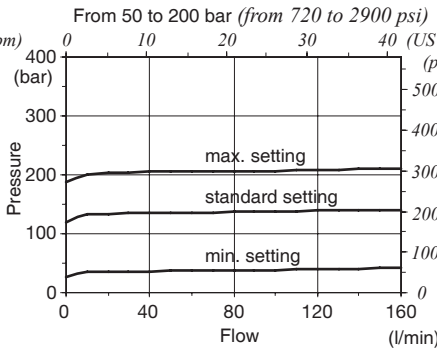

LSW(G4) main relief valve setting range

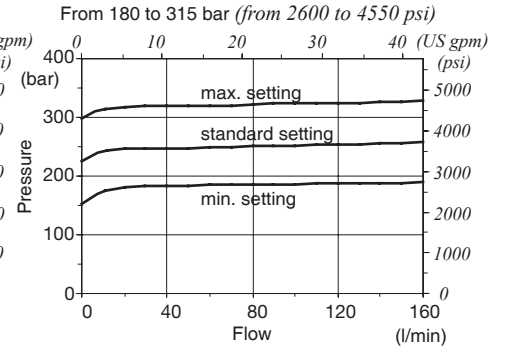

Pressure drop P → T on flow cut-out

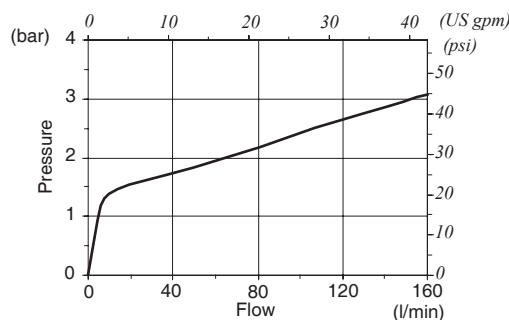

Configuration with priority valve

FE SDS180 / ACD / VPD (LSZ - 230) \ YG3 - 120) - SAE

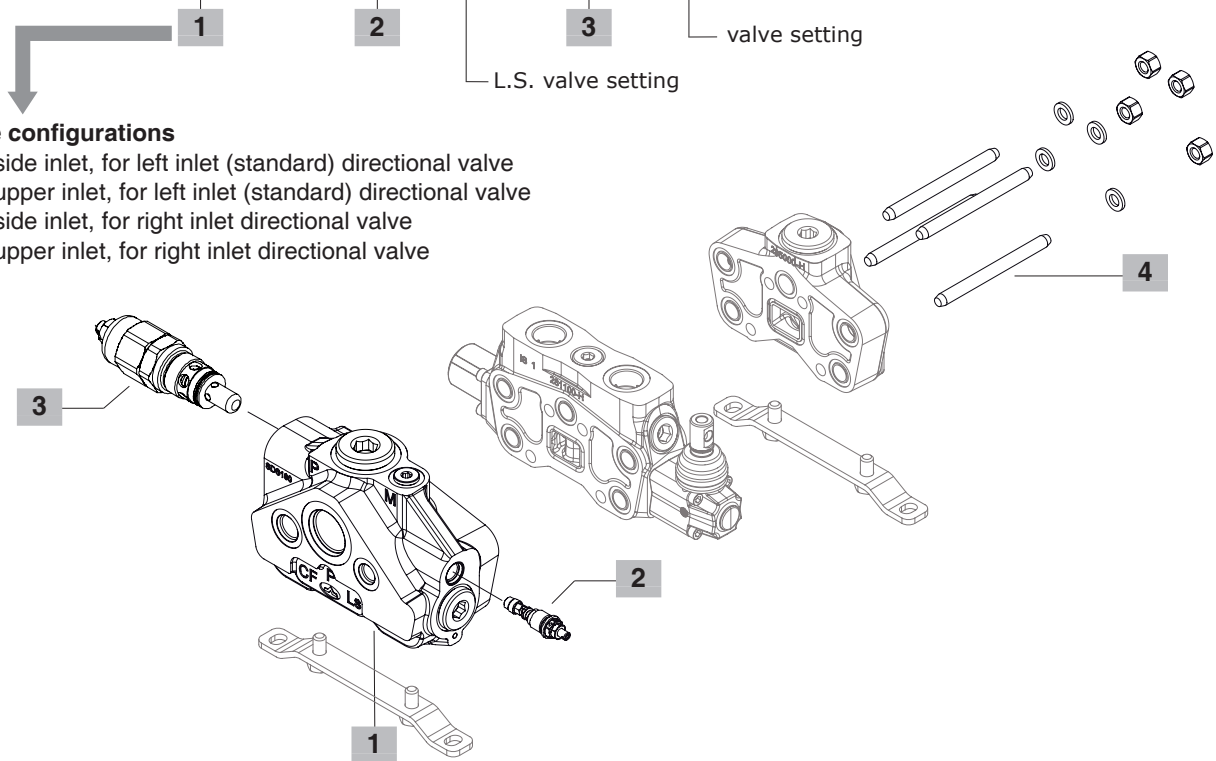

Available configurations

- AC: with side inlet, for left inlet (standard) directional valve
- AD: with upper inlet, for left inlet (standard) directional valve
- BC: with side inlet, for right inlet directional valve
- BD: with upper inlet, for right inlet directional valve

1 Inlet cover body * page 23

CODE: 5FIA118320
DESCRIPTION: With priority valve

2 L.S. relief valve options page 23

Standard setting is referred to 10 l/min (2.6 US gpm) flow.

TYPE	CODE	DESCRIPTION
LSD	XCAR126215	Range 40-180 bar (580-2600 psi) standard setting 90 bar (1300 psi)
	XCAR126213	Range 180-350 bar (2600-5000 psi) standard setting 180 bar (2600 psi)
LSH	XCAR126216	Range 40-180 bar (580-2600 psi) standard setting 90 bar (1300 psi)
	XCAR126217	Range 180-350 bar (2600-5000 psi) standard setting 180 bar (2600 psi)
LSZ	5CAR126221	Range 40-180 bar (580-2600 psi) standard setting 90 bar (1300 psi)
	5CAR126219	Range 130-350 bar (1900-5000 psi) standard setting 180 bar (2600 psi)
ST	5KIT126210	Relief valve blanking plug

3 Inlet valve options page 13

Standard setting is referred to 10 l/min (2.6 US gpm) flow.

TYPE	CODE	DESCRIPTION
SV	3XTAP535410	Relief valve blanking plug
VMP20/1 pilot operated pressure relief valve type X (XG-120)		
	X007211120	Range 60-250 bar (900-3600 psi) standard setting 120 bar (1750 psi)
	XCAR120313	As previous without filter
VMD20/1 direct pressure relief valve type Y (standard) (YG2-80)		
	3XCAR120212	Range 63-125 bar (900-1800 psi) standard setting 80 bar (1150 psi)
	3XCAR120213	Range 100-200 bar (1450-2900 psi) standard setting 175 bar (2500 psi)
	3XCAR120214	Range 160-320 bar (2300-4650 psi) standard setting 250 bar (3600 psi)
Double stage relief valve (pilot port SAE 8) (XGD-207-235)		
	1130040408	Setting 207 and 235 bar (3000 and 3400 psi)

4 Assembling kit

CODE	DESCRIPTION
5TIR4161	Tie rod kit for 1 working sectional valve
5TIR4162	Tie rod kit for 2 working sectional valve
5TIR4163	Tie rod kit for 3 working sectional valve
5TIR4164	Tie rod kit for 4 working sectional valve
5TIR4165	Tie rod kit for 5 working sectional valve
5TIR4166	Tie rod kit for 6 working sectional valve
5TIR4167	Tie rod kit for 7 working sectional valve
5TIR4168	Tie rod kit for 8 working sectional valve
5TIR4169	Tie rod kit for 9 working sectional valve
5TIR416A	Tie rod kit for 10 working sectional valve

NOTE (*) - Codes are referred to **BSP** thread.

Configuration with priority valve

Dimensional data and hydraulic circuit

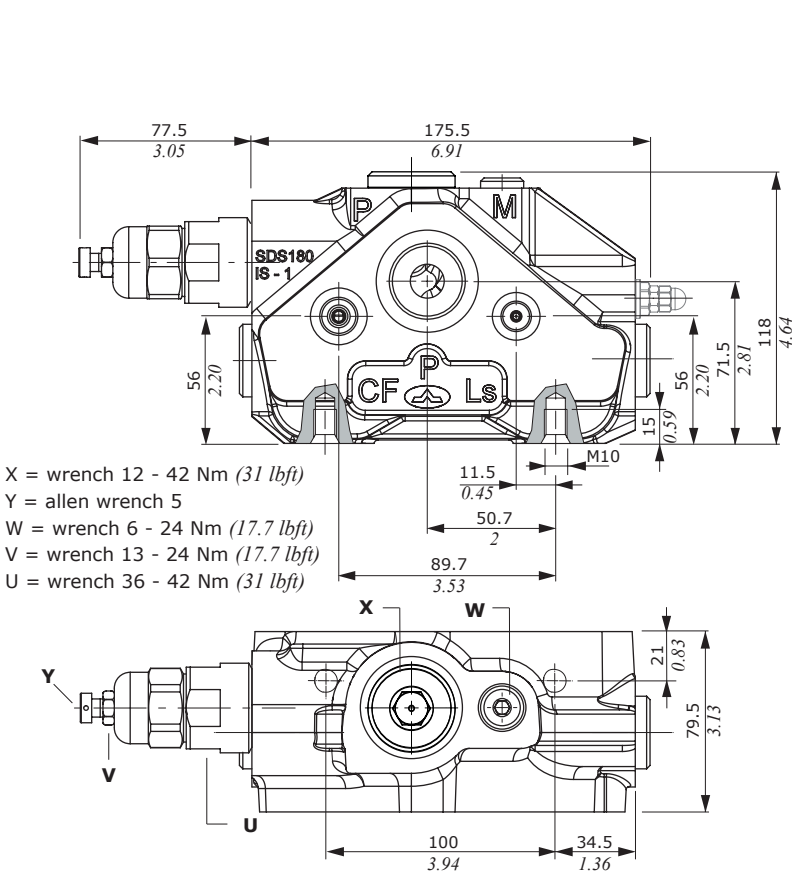

Load Sensing pressure relief valves

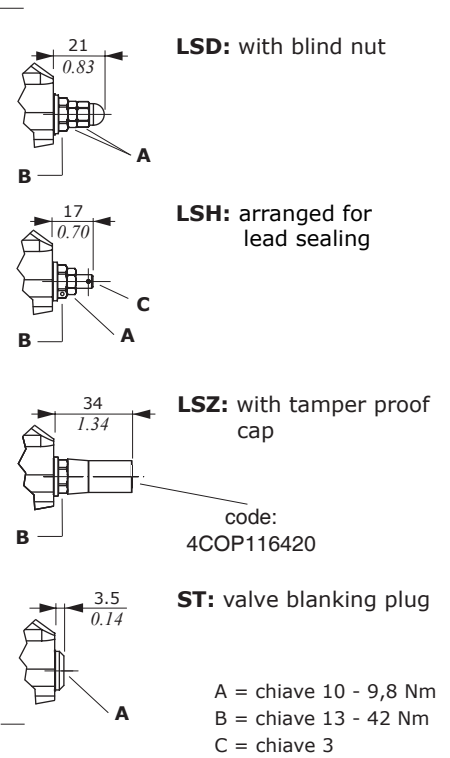

- X = wrench 12 - 42 Nm (31 lbft)
- Y = allen wrench 5
- W = wrench 6 - 24 Nm (17.7 lbft)
- V = wrench 13 - 24 Nm (17.7 lbft)
- U = wrench 36 - 42 Nm (31 lbft)

Stand-by pressure vs. regulated flow for various values of inlet flow

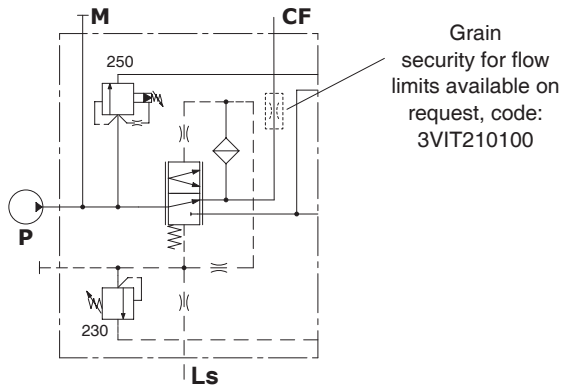
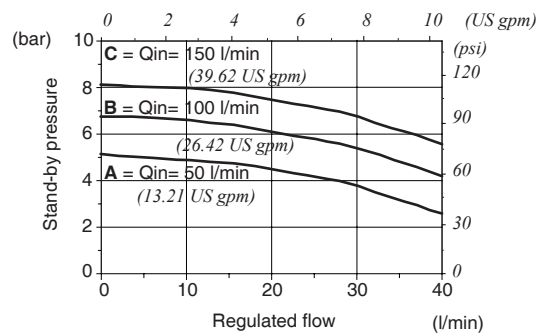

Valve diagrams

LSH, LSD valve and LSZ setting range

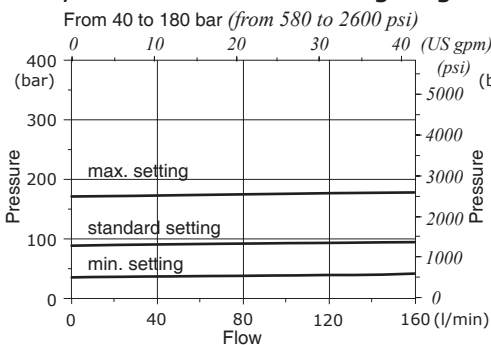

LSH and LSD valve setting range

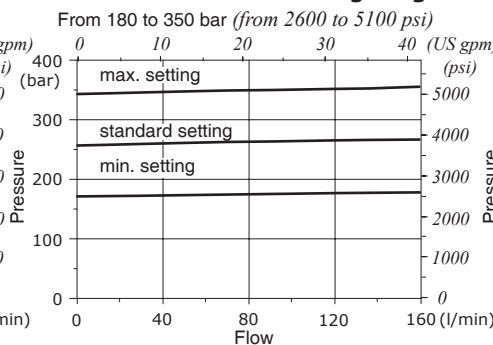

LSZ valve setting range

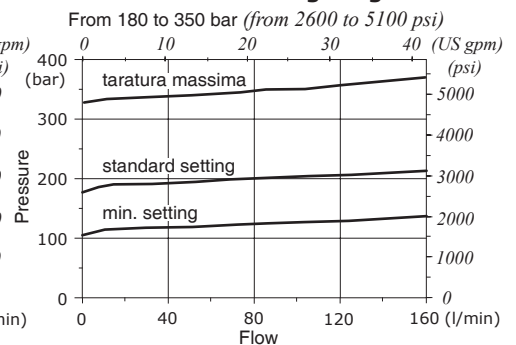

Configuration with unloader operation spool type

SDS180 / BCHW (LSW - 250) ELNW(NO) - 12VDC

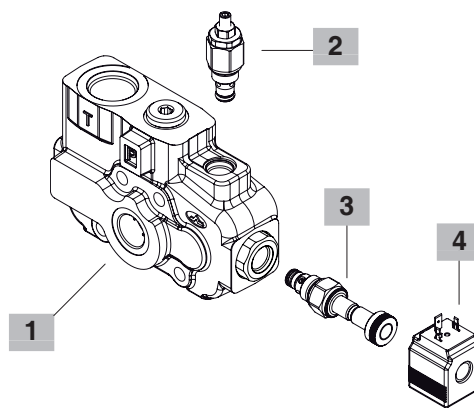
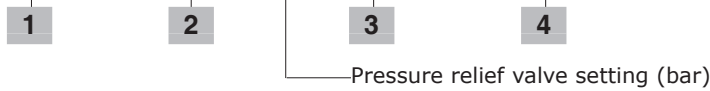

1 Inlet cover body * page 25

CODE: 5FIA118373

DESCRIPTION: with unloader operation spool type

2 Inlet relief valve options page 25

Standard setting is referred to 10 l/min (2.6 US gpm) flow.

TYPE	CODE	DESCRIPTION
SV	XTAP525320	Relief valve blanking plug

Main relief valve

LSW(G2)FC07	5KIT118120	Range 5-50 bar (72-720 psi) standard setting 30 bar (400 psi)
LSW(G3)FC07	5KIT118121	Range 50-200 bar (720-3200 psi) standard setting 150 bar (2150 psi)
LSW(G4)FC07	5KIT118122	Range 180-315 bar (2600-4550 psi) standard setting 250 bar (3600 psi)

3 Pilot solenoid valve options page 25

TYPE	CODE	DESCRIPTION
ELNW(NO)	0EF08002000	Without manual emergency, NO circuit
ELNW(NC)	0EF08002001	Without manual emergency, NC circuit
ELTW(NO)	0EF08002004	"Push&twist" manual emergency, NO circuit
ELPW(NO)	0EF08002002	Push-button manual emergency, NO circuit
ELVW(NO)	0EF08002003	Screw type manual emergency, NO circuit

4 Coils page 76

TYPE	CODE	DESCRIPTION
12VDC	4SLE001200	BER type, 12VDC, ISO4400 connector

For complete available coils list see page 76

NOTE (*) – Codes are referred to BSP thread.

Configuration with unloader operation spool type

Dimensional data and hydraulic circuit

- X = wrench 8 - 24 Nm (17.7 lbft)
- Y = wrench 10 - 24 Nm (17.7 lbft)
- W = allen wrench 4
- V = wrench 13
- U = wrench 24 - 30 Nm (22.1 lbft)
- R = wrench 32 - 42 Nm (31 lbft)

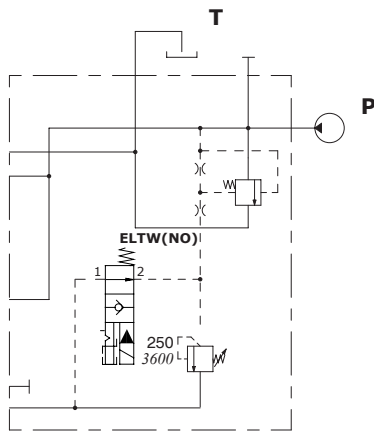
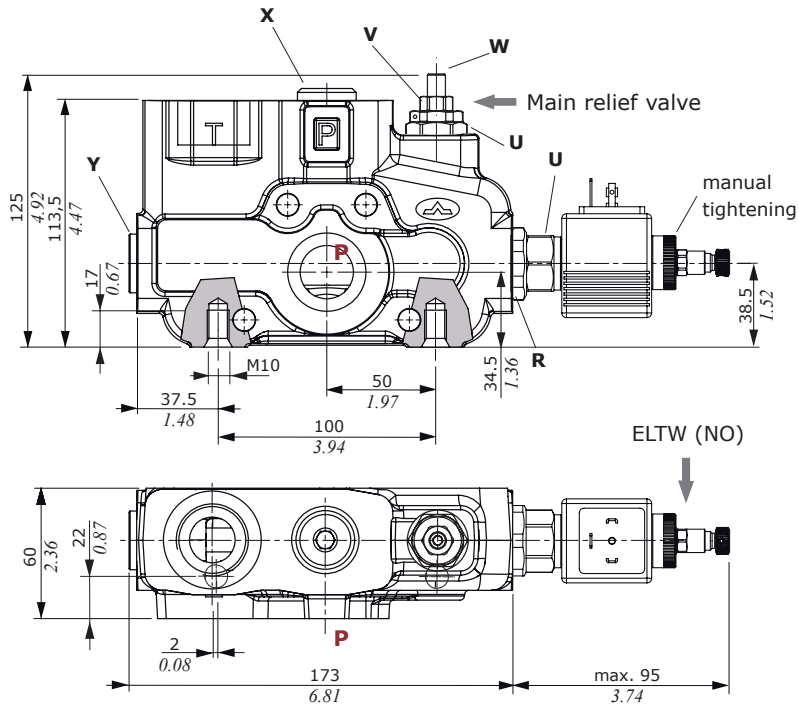

ELNW(NO): without emergency push button type "push & twist" type

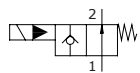

ELPW(NO):

without emergency push button type "push & twist" type

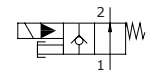

ELTW(NO):

without emergency push button type "push & twist" type

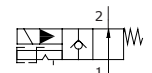

ELVW(NO): screw type

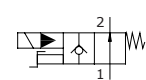

ELNW(NC): without emergency

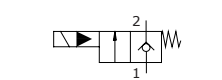

Valve diagrams

Pressure drop P ⇒ T
with unloader operation spool type
on SDS 180/4

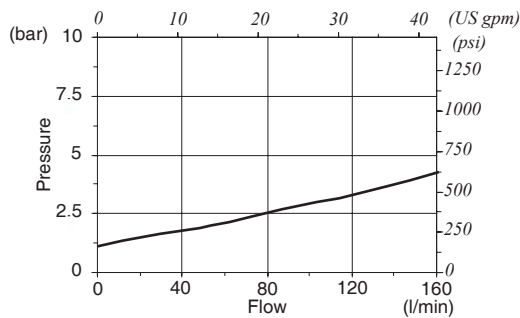

NOTE - For other valve diagrams see page 21.

Parts ordering codes (mechanical control)

EL SDS180 / (P) - 1 8 L . P1 (G3 - 100)

P type omitted in description

1
 2a
 3
 4
 5a

Pressure relief valve setting (bar)

EL SDS180 / RPHT - 1 8 L . U (100)

1
 2a
 3
 4
 5b

Pressure relief valve fixed setting (bar)

EL SDS180 / RPH5LL - 5HFL 8 L . U (100)

1
 2b
 3
 4
 5b

Pressure relief valve fixed setting (bar)

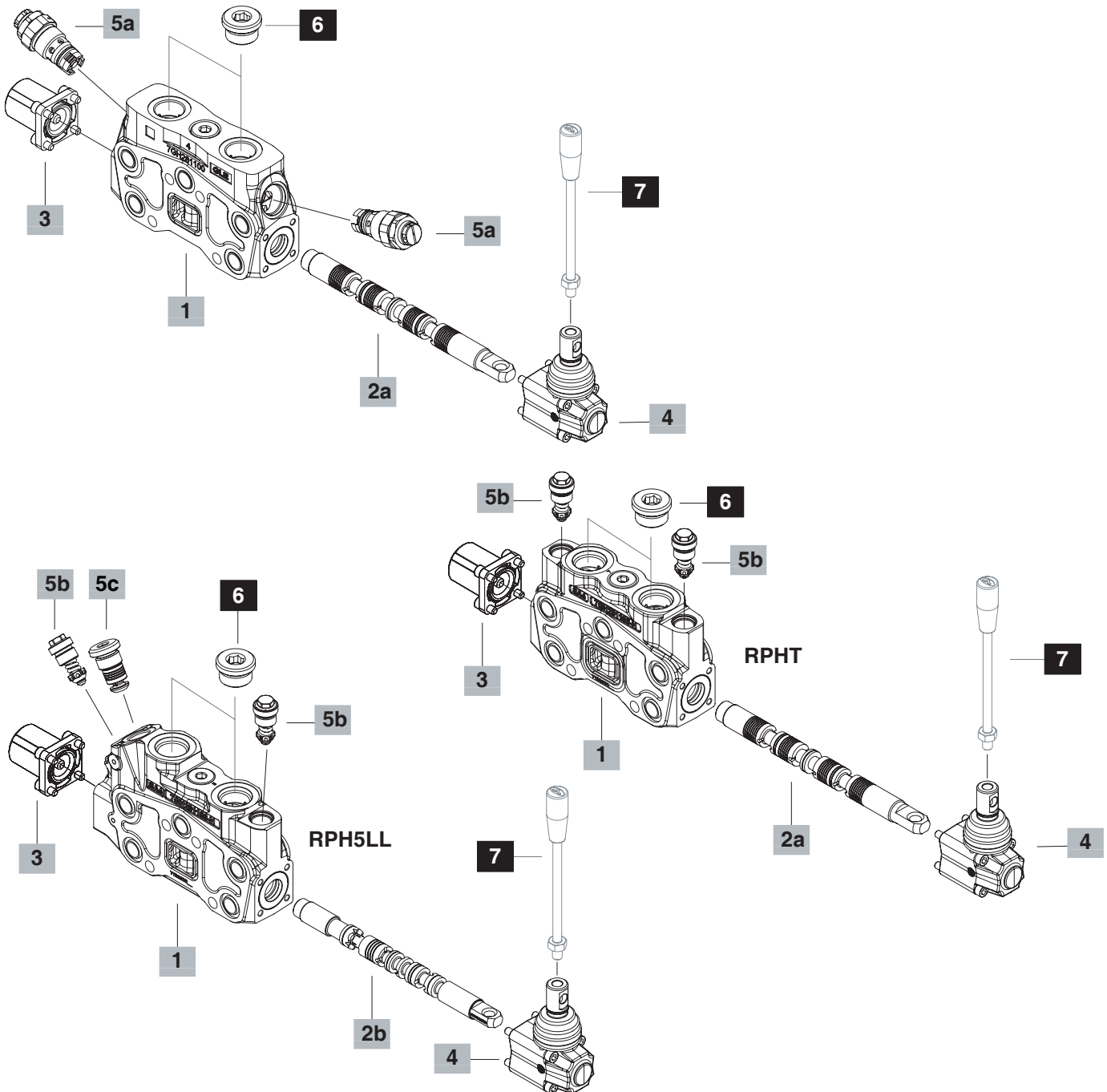

Parts ordering codes (mechanical control)

1 Working section kit * page 30		
TYPE	CODE	DESCRIPTION
P	5EL1183000	For parallel circuit (omitted in description)
	5EL1183000C	As previous , for spool positioners 8MG3, 8MG19/29(NO), 8PDG, 8PG, 8EPDG3, 8EPG3, 11A, 8PGR and 8EPG3
SP	5EL3183001	For tandem circuit
S	5EL2163000	For series circuit
P5	5EL1183201	For parallel circuit and floating circuit
PES	5EL1163000	For parallel circuit, for valve with series circuit (page 7)
PHT	5EL1183080	For parallel circuit, for spools 1TX and 1TYD
PHD	5EL1183020	For parallel circuit, for spools 1CSG and 1CSGH
RPHT	5EL1183057-H	For parallel circuit with upper arrangement for fixed setting port valves
RPH5	5EL1183250-H	For parallel circuit with floating circuit with upper arrangement for fixed setting port valves
RPHSP	5EL1183059-H	For tandem circuit with upper arrangement for fixed setting port valves
RSP5	5EL3183250-H	For tandem circuit with floating circuit with upper arrangement for fixed setting port valves
RQHT	5EL1183056-H	For parallel circuit without upper arrangement for port valves
RPH5LL	5EL1183065-H	For parallel circuit with floating circuit with with arrangement for low leak valve for spool 5HFLL

2a Spools** page 34		
TYPE	CODE	DESCRIPTION
1	3CU2510100	Double acting, 3 positions, with A and B closed in neutral position
1(11A)	3CU2510321	As previous, need spool positioner 11A and dedicated working section kit
1CS	3CU2510200	As type 1, sensitive type
1CSG	3CU2510250	Double acting with A and B closed in neutral position, B partially connect to tank in position 1, A partially connect to tank in position 2; for section kit PHD
1CSGH	3CU2510251	As previous, sensitive type; for section kit PHD
1A	3CU2521100	Double acting, 3 positions, with A open to tank in neutral position
1B	3CU2522100	Double acting, 3 positions, with B open to tank in neutral position
1D	3CU2510210	As type 1, sensitive type for flow up to 100 l/min (26.42 USgpm)
1TX	3CU2510601	Double acting with A and B closed in neutral position, B partially connect to tank in position 1, A partially connect to tank in position 2; needs section kit PHT

2a Spools (continued)** page 34		
TYPE	CODE	DESCRIPTION
1TYD	3CU2510603	As previous, B with restricted connection to tank; needs section kit PHT
2	3CU2525100	Double acting, 3 positions, with A and B open to tank in neutral position
2H	3CU2525225	Double acting 3 positions, with A and B partially open to tank in neutral position
3	3CU2531100	Single acting on A, 3 positions, B plugged; requires G3/4 plug
4	3CU2535100	Single acting on B, 3 positions, A plugged; requires G3/4 plug
5	3CU2541200	Double acting spool with A and B closed in neutral position, 4 positions, with spool in, floating 4 th position: need dedicated positioner kit type 13MD
5B	3CU2541203-H	Double acting spool with A and B closed in neutral position, 4 positions, with spool out, floating 4 th position: need dedicated positioner kit type 13C
8PF	3CU2561210	Double acting 3 positions, regenerative circuit in 3 rd position with spool in: need dedicated positioner kit
8PFG	3CU2561215	Double acting 3 positions, regenerative circuit in 2 nd position with spool out: need dedicated positioner kit

2b Spools** page 34		
TYPE	CODE	DESCRIPTION
5HFLL	3CU2541209-H	Double acting spool with A and B closed in neutral position, 4 positions, with spool in, floating 4 th position: for RPH5LL working section kit

3 "A" side spool positioners page 36		
TYPE	CODE	DESCRIPTION
8	5V08110000	With spring return in neutral position
8TL	5V08110310	As type 8, for flexible cable control
8F2	5V08110101	As type 8 with adjustable stroke limiter
11	5V11110000	Detent in positions neutral, 1 and 2
12	5V12110000	Detent in positions 1 and 2
15	5V15110000	2 positions, detent in positions 1 and neutral
16	5V16110000	2 positions, detent in positions 2 and neutral
9BZ	5V09110030	With detent in position 1 and spring return in neutral position
10BZ	5V10110030	With detent in position 2 and spring return in neutral position
11BZ	5V11110030	Detent in positions 1 and 2 and spring return in neutral position

continued

NOTE (*) – Codes are referred to **BSP** thread.

(**) For special features of the various spools please contact our Sales Dpt

Parts ordering codes (mechanical control)

3 "A" side spool positioners (cont.) page 36

TYPE	CODE	DESCRIPTION
8MG3	5V08110050	As type 8, operation with microswitch (NO) in positions 1 and 2 ⁽¹⁾
8MG19/29(NO)	5V08110080	As type 8, operation with 2 microswitch (NC) in positions 1 and 2 ⁽¹⁾
8RMN2	5V08416030	12 VDC with electromagnetic detent
	5V08416040	24 VDC with electromagnetic detent
8K	5V08710112	As type 8 and 12 VDC solenoid lock device
	5V08710124	As previous, 24 VDC
8PDG	5V08110710	ON/OFF pneumatic waterproof kit ⁽¹⁾
8PG	5V08110708	ON/OFF pneumatic kit ⁽¹⁾
8EPDG3	5V08110740	12 VDC ON/OFF pneumatic waterproof kit ⁽¹⁾
	5V08110738	24 VDC ON/OFF pneumatic waterproof kit ⁽¹⁾
8EPG3	5V08110725	12 VDC ON/OFF electro-pneumatic kit ⁽¹⁾
	5V08110726	24 VDC ON/OFF electro-pneumatic kit ⁽¹⁾
8EI3	5V08110320	12 VDC ON/OFF electro-hydraulic kit
	5V08110321	24 VDC ON/OFF electro-hydraulic kit
11A	5V11510110	With detent in positions 1 and 2, automatic release in neutral position ⁽²⁾
13MD	5V13416010	4 positions, detent in 4 th position with spring return in neutral position with detent pull type. Needs spool type 5
13C	5V13116005	4 positions, detent in 4 th pos. with spring return in neutral pos. with detent push type. Needs spool type 5B

Positioner kit for 8PF and 8PFG regenerative spools:
Overall dimensions are the same ones as those of standard controls listed above.

8CR	5V08110020	With spring return in neutral position
9BCR	5V09110020	With detent in position 1 and spring return in neutral position
8PGCR	5V08110706	ON/OFF pneumatic kit ⁽¹⁾
8EPG3CR	5V08110727	12 VDC electro-pneumatic kit ON/OFF ⁽¹⁾
	5V08110728	24 VDC electro-pneumatic kit ON/OFF ⁽¹⁾
8EI3CR	5V08110357	12 VDC electro-hydraulic kit ON/OFF
	5V08110353	24 VDC electro-hydraulic kit ON/OFF

4 "B" side options page 44

TYPE	CODE	DESCRIPTION
L	5LEV110000	Standard lever box
LF1	5LEV110101	Lever box with spool stroke limiter in position 1
LB	5LEV310000	Steel lever kit
LCB	5CLO216100	Joystick lever for 2 sections operation
LCE	5CLO216050	As previous with bronze support
SL	--	Without lever box
SLP	5COP110000	Without lever box, with dust-proof plate
TQ	5TEL110110	Flexible cable connection; for CD cables

5a Port valves page 51

Valves standard setting is referred to 10 l/min (2.64 USgpm) flow.

TYPE	CODE	DESCRIPTION
-	XTAP530361	Valve blanking plug (omitted in description)
C	3XCAR416100	Anti-cavitation valve
Anti-shock valve		
P(G2)	XCAR216115	Range 50-120 bar (725-1750 psi) standard setting 63 bar (900 psi)
P(G3)	XCAR216116	Range 100-250 bar (1450-3600 psi) standard setting 100 bar (1450 psi)
P(G4)	XCAR216117	Range 160-315 bar (2300-4600 psi) standard setting 200 bar (2900 psi)
Pilot hydraulic unloader valve		
PX	XCAR416301	Pilot hydraulic unloader valve
Anti-shock and anti-cavitation valve		
U(G2)	X011411099	Range 35-90 bar (510-1300 psi) standard setting 60 bar (870 psi)
U(G3)	X011411100	Range 90-250 bar (1300-3600 psi) standard setting 100 bar (1800 psi)
U(G4)	X011411101	Range 180-350 bar (2600-5100 psi) standard setting 200 bar (2900 psi)
Pilot operated anti-shock and anti-cavitation valve		
UXW(G)	X01141B160	Range 63-315 bar (900-4600 psi) standard setting 160 bar (2300 psi)

NOTE (1) - Needs dedicated working section kit.
(2) - Needs dedicated working section kit and type spool 1(11A).

Parts ordering codes (mechanical control)

5b Port valves page 56**For RPH and RPH5LL working section kit**

TYPE	CODE	DESCRIPTION
UT	XTAP522441	Valve blanking plug
C	5KIT410000	Anticavitation valve

Fixed setting antishock and anticavitation valves:

setting is referred to 10 l/min (2.6 US gpm)

U025	5KIT330025	Setting 25 bar (363 psi)
U030	5KIT330030	Setting 30 bar (435 psi)
U040	5KIT330040	Setting 40 bar (580 psi)
U050	5KIT330050	Setting 50 bar (725 psi)
U063	5KIT330063	Setting 63 bar (914 psi)
U080	5KIT330080	Setting 80 bar (1150 psi)
U100	5KIT330100	Setting 100 bar (1450 psi)
U110	5KIT330110	Setting 110 bar (1590 psi)
U125	5KIT330125	Setting 125 bar (1800 psi)
U140	5KIT330140	Setting 140 bar (2050 psi)
U150	5KIT330150	Setting 150 bar (2150 psi)
U160	5KIT330160	Setting 160 bar (2300 psi)
U175	5KIT330175	Setting 175 bar (2550 psi)
U190	5KIT330190	Setting 190 bar (2750 psi)
U200	5KIT330200	Setting 200 bar (2900 psi)
U210	5KIT330210	Setting 210 bar (3050 psi)
U220	5KIT330220	Setting 220 bar (3190 psi)
U230	5KIT330230	Setting 230 bar (3350 psi)
U240	5KIT330240	Setting 240 bar (3500 psi)
U250	5KIT330250	Setting 250 bar (3600 psi)
U260	5KIT330260	Setting 260 bar (3750 psi)
U270	5KIT330270	Setting 270 bar (3900 psi)
U280	5KIT330280	Setting 280 bar (4050 psi)
U290	5KIT330290	Setting 290 bar (4200 psi)
U300	5KIT330300	Setting 300 bar (4350 psi)
U310	5KIT330310	Setting 310 bar (4500 psi)

5c Low leak valves page 56

TYPE	CODE	DESCRIPTION
LL	5KIT918002	Low leak valve

6 Port plugs *

CODE	DESCRIPTION
3XTAP732200	G3/4 Plug

7 Optional hand levers

TYPE	CODE	DESCRIPTION
AL01/M10x200	170012020	For L lever box, L= 200 mm (7.87 in)
AL08/M12x250	170013125	For LCB joystick, L= 250 mm (9.84 in)

NOTE (*) – Codes are referred to **BSP** thread.

Parts ordering codes (proportional hydraulic control)

- P type omitted in description
- EL SDS180 / (P) - 1IM 8IM . U1 (G3 - 100)
- 1 2a 3 4a — Pressure relief valve setting (bar)
- EL SDS180 / RPHT - 1IM 8IM L . U (100)
- 1 2a 3 4 5b — Pressure relief valve fixed setting (bar)
- EL SDS180 / RPH5LL - 5HFLL 8IM L . U (100)
- 1 2b 3 4 5b — Pressure relief valve fixed setting (bar)

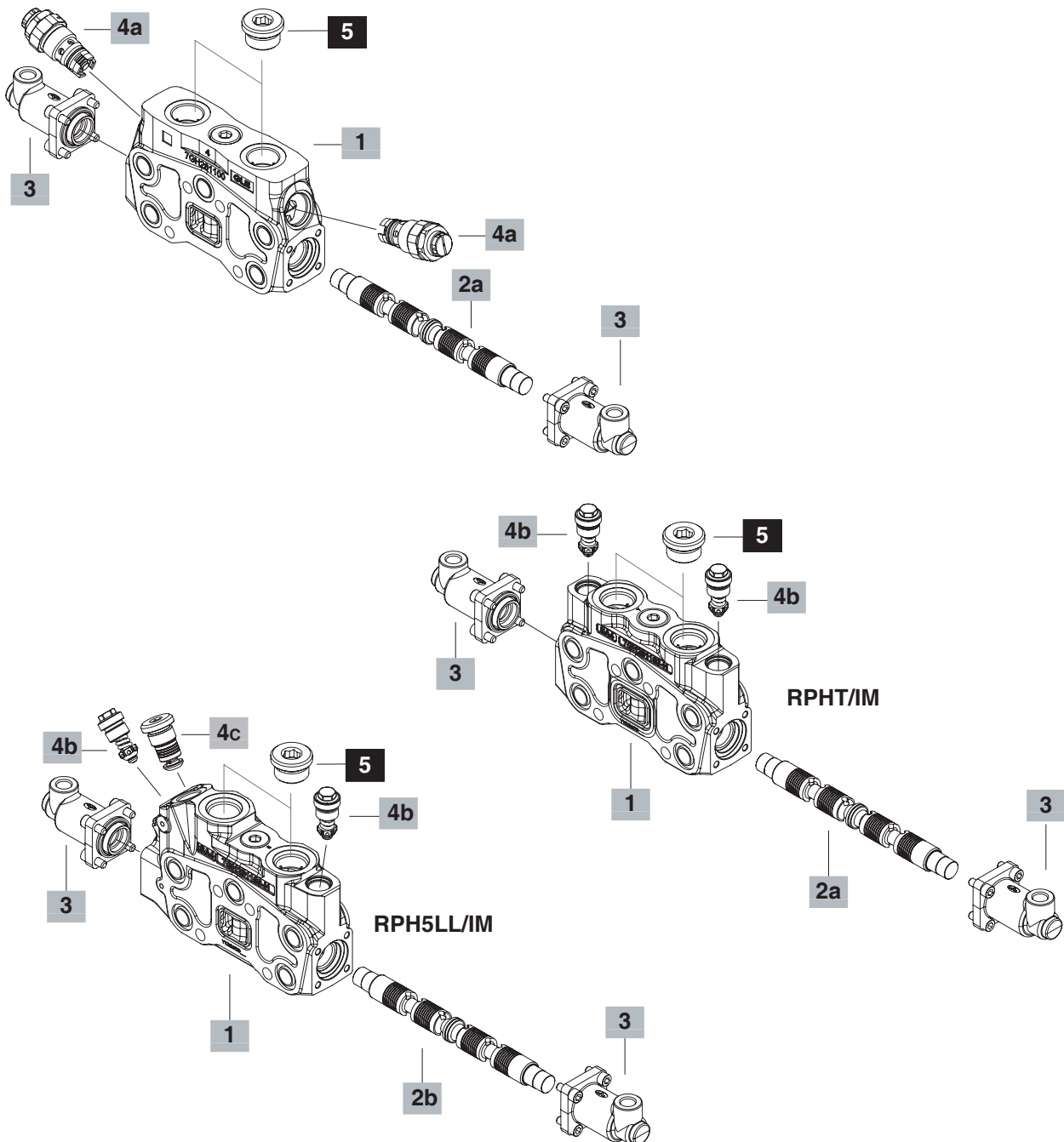

Parts ordering codes (proportional hydraulic control)

1 Working section kit * page 32

TYPE	CODE	DESCRIPTION
P/IM	5EL1183000A	For parallel circuit with proportional hydraulic control (omitted in description)
P5/IMP	5EL1183205A	As previous for floating circuit: need spool type 5IMP and complete controls 13IMP
SP/IM	5EL3183001B	With tandem circuit
SP5/IM	5EL3183202	As previous for floating circuit
PHD/IM	5EL1183020A	For parallel circuit, need spool 11MDA
RPHT/IM	5EL1183057A-H	For parallel circuit with upper arrangement for fixed setting port valves
RPH5/IM	5EL1183250A-H	For parallel circuit with floating circuit with upper arrangement for fixed setting port valves
RPHSP/IM	5EL1183059A-H	For tandem circuit with upper arrangement for fixed setting port valves
RSP5/IM	5EL3183250-H	For tandem circuit with floating circuit with upper arrangement for fixed setting port valves
RQHT/IM	5EL1183061-H	For parallel circuit without upper arrangement for port valves
RPH5LL/IM	5EL1183065A-H	For parallel circuit with arrangement for load leak valve need spool type 5HFLIM and control type 131MOPHCR

2a Spools page 34

TYPE	CODE	DESCRIPTION
1IM	3CU2510420	Double acting with A and B closed in neutral position
11MDA	3CU2510490	As type 1IM with descent control and load check valve without power supply on port A: need working section PHD/IM and control type 8IMD
1A1M	3CU2522420	Double acting with A open to tank in neutral position
1B1M	3CU2522420	Double acting with B open to tank in neutral position
2H	3CU2525425	Double acting with A and B partially connect to tank in neutral position
2IM	3CU2525420	Double acting with A and B connect to tank in neutral position
3IM	3CU2535420	Single acting on A, B plugged
4IM	3CU2535420	Single acting on B; A plugged
5IMP	3CU2542430	Double acting spool with A and B closed in neutral position, spool out floating 4 th position: need working section P5/IMP and control type 13 IMP
11M(8IMSP)	3CU2510491	As type 11M: need control type 81MSPSL4P

2b Spools page 34

TYPE	CODE	DESCRIPTION
5HFLIM	3CU2541210-H	As 5IMP need working section RPH5LL and control type 131MOPHCR

3 Complete controls * page 47**Proportional Hydraulic control**

TYPE	CODE	DESCRIPTION
8IM	5IDR216300	Zama control kit. Range 5.8-19 bar (84-270 psi)
8IMD	5IDR218300	Zama control kit. Range 5.8-19 bar (84-270 psi): working section for PHD/IM and spool type 11MDA
8IMF3	5IDR216303	Zama control kit with screws spool stroke adjusting. Range 5.8-19 bar (84-270 psi)
81MSPSL	5IDR218012	Zama control kit with spool position sensor execution. Range 0.8-4.2 bar (11-60 psi): need spool type 11M(8IMSP)
81MOH	5IDR216000-H	Steel control kit. Range 5.8-19 bar (84-270 psi)
13IMP	5IDR216014	Control kit for floating circuit. Range 5.8-14 bar (84-270 psi): need working section P5/IMP and spool type 5IMP
131MOPHCR	5IDR216015-H	Control kit for floating circuit. Range 3.5-18 bar (51-261 psi): need working section RPH5LL/IM and spool type 5HFLIM

4a Port valves page 51

See page 28.

4b Port valves page 56

See page 29.

4c Low leak valve page 56

TYPE	CODE	DESCRIPTION
LL	5KIT918002	Low leak valve

5 Port plugs *

CODE	DESCRIPTION
3XTAP732200	G3/4 Plug

NOTE (*) – Codes are referred to **BSP** thread.

Dimensional data and hydraulic circuit

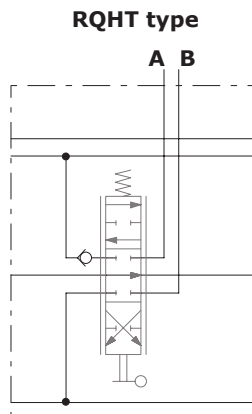
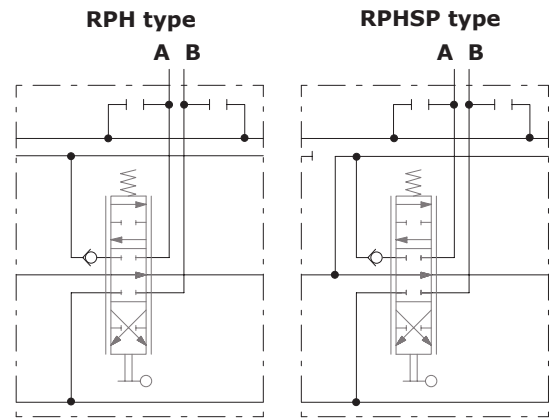
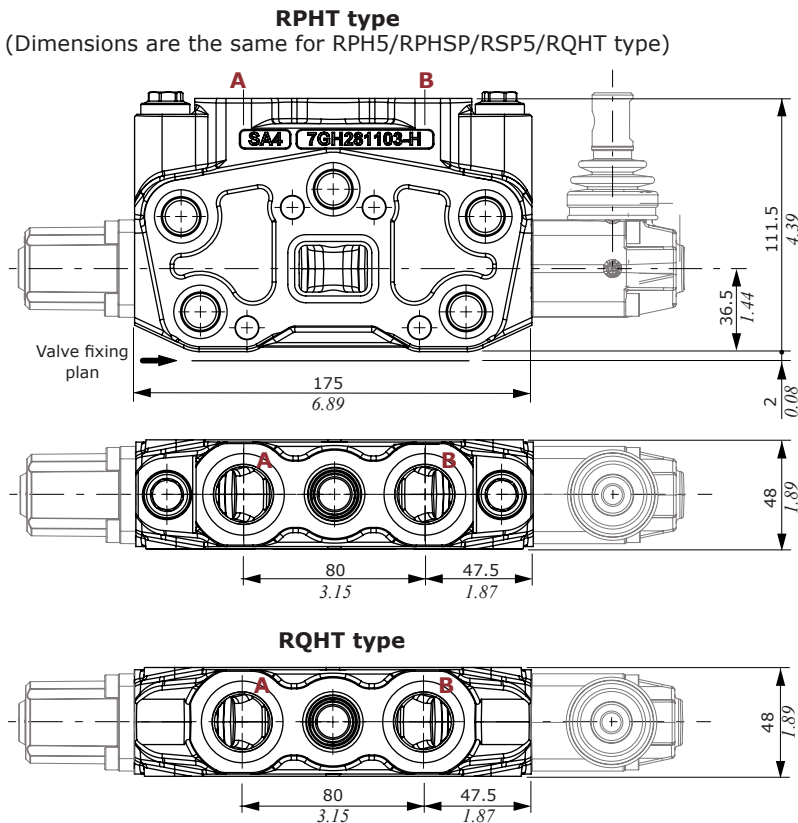
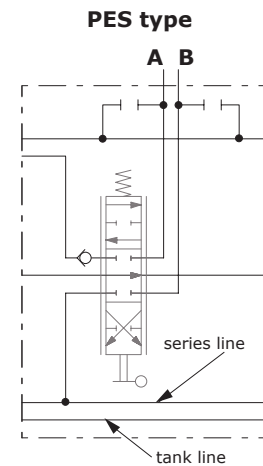
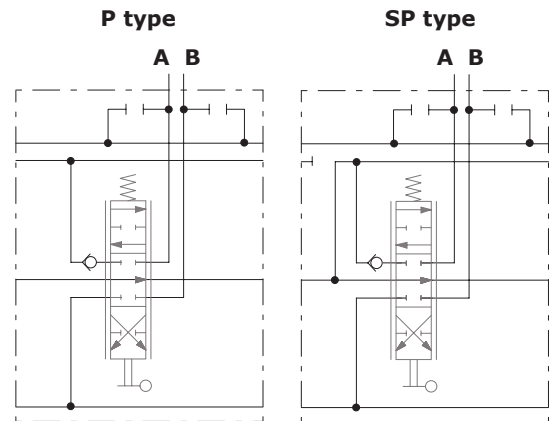
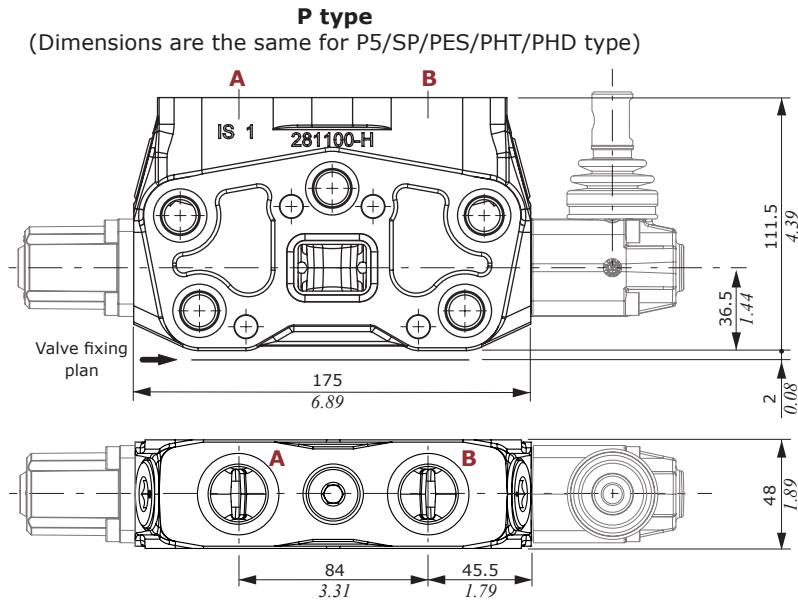

Dimensional data and hydraulic circuit

RPH5LL type

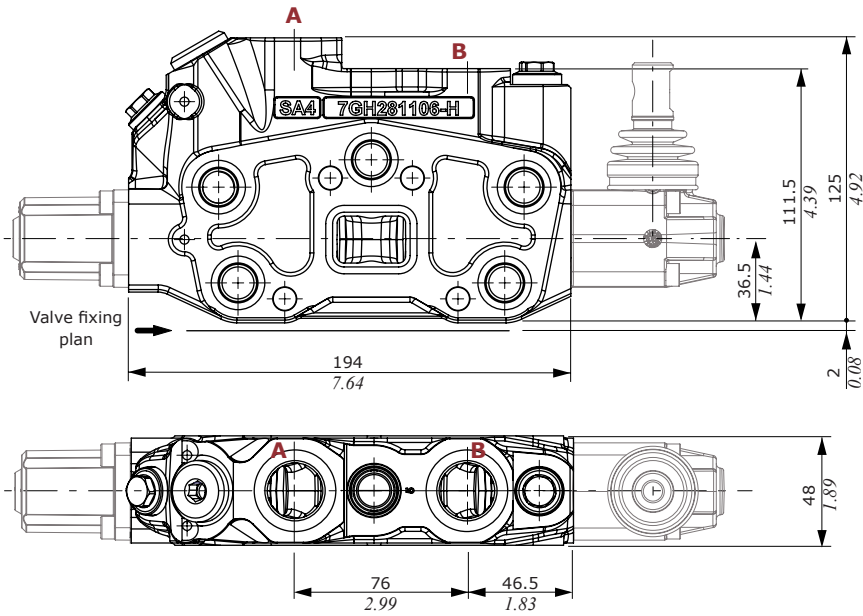

RPH5LL type
A B

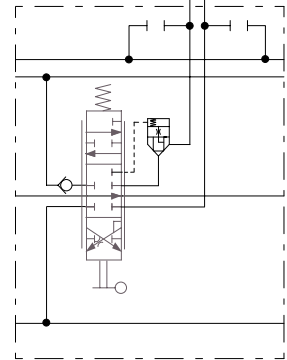

S type

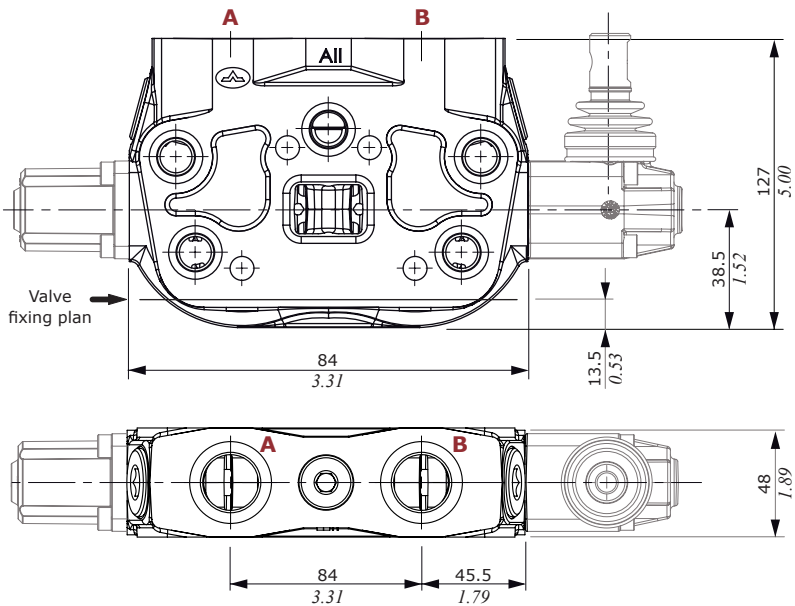

S type
A B

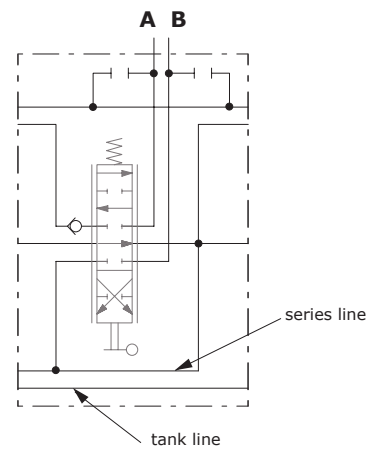

Spools

Type 1 (1D/1CS/1[11A]/1IM) spool

Double acting, 3 positions, with A and B closed in neutral position

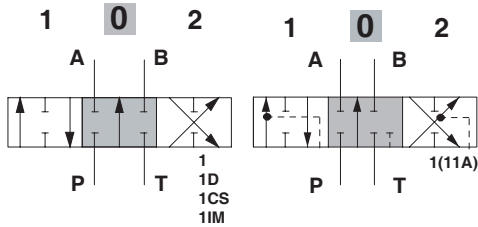

Spool stroke

position 1: + 7 mm (+ 0.28 in)
position 2: - 7 mm (- 0.28 in)

Type 1 spool metering

$Q_{in} = 160 \text{ l/min} / (42 \text{ US gpm})$
 $P_{(on ports)} = 100 \text{ bar} / (1450 \text{ psi})$

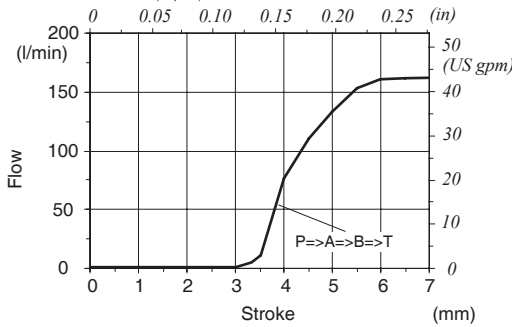

Type 2 (2IM) spool

Double acting, 3 positions, with A and B open to tank in neutral position

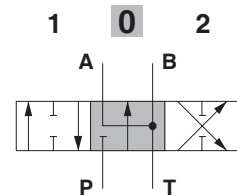

Spool stroke

position 1: + 7 mm (+ 0.28 in)
position 2: - 7 mm (- 0.28 in)

Type 1A (1AIM) spool

Double acting, 3 positions, with A open to tank in neutral position

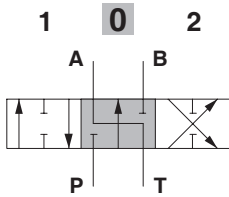

Spool stroke

position 1: + 7 mm (+ 0.28 in)
position 2: - 7 mm (- 0.28 in)

Type 1B (1BIM) spool

Double acting, 3 positions, with B open to tank in neutral position

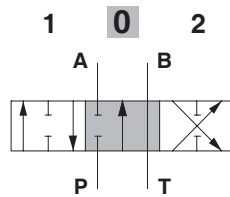

Spool stroke

position 1: + 7 mm (+ 0.28 in)
position 2: - 7 mm (- 0.28 in)

Type 2H spool

Double acting, 3 positions, with A and B partially open to tank in neutral position

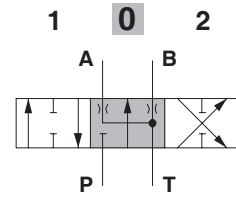

Spool stroke

position 1: + 7 mm (+ 0.28 in)
position 2: - 7 mm (- 0.28 in)

Type 3 (3IM) spool

Single acting on A, 3 positions, B plugged; requires G3/4 plug

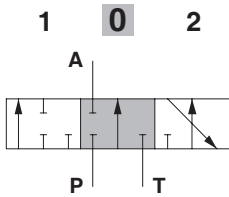

Spool stroke

position 1: + 7 mm (+ 0.28 in)
position 2: - 7 mm (- 0.28 in)

Type 4 (4IM) spool

Single acting on B, 3 positions, A plugged; requires G3/4 plug

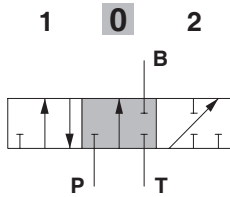

Spool stroke

position 1: + 7 mm (+ 0.28 in)
position 2: - 7 mm (- 0.28 in)

Type 5B spool

Double acting spool with A and B closed in neutral position, 4 positions, with spool out, floating 4th position (pos.3)

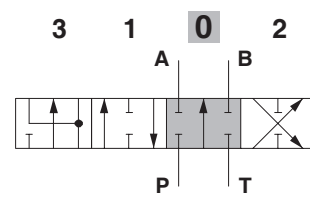

Spool stroke

position 1: + 6 mm (+ 0.24 in)
position 2: - 6 mm (- 0.24 in)
position 3: + 12 mm (+ 0.47 in)

Type 5 (5IMP) and 5HFL spool

Double acting spool with A and B closed in neutral position, 4 positions, with spool in, floating 4th position (pos.3)

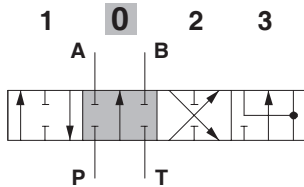

Type 5 (5IMP) Spool stroke

- position 1: + 6 mm (+ 0.24 in)
- position 2: - 6 mm (- 0.24 in)
- position 3: - 12 mm (- 0.47 in)

Type 5HFL Spool stroke

- position 1: + 6.5 mm (+ 0.25 in)
- position 2: - 6.5 mm (- 0.25 in)
- position 3: - 12.5 mm (- 0.49 in)

Type 5 spool metering

$Q_{in} = 160 \text{ l/min} / (42 \text{ US gpm})$
 $P_{(on ports)} = 100 \text{ bar} / (1450 \text{ psi})$

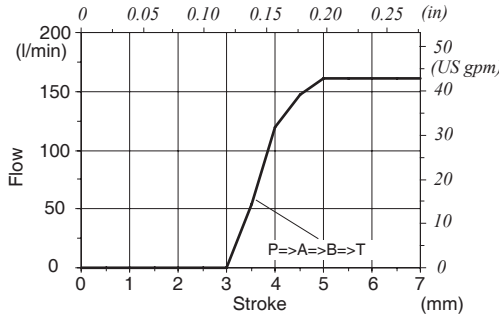

Type 5 spool pressure drop in position 3

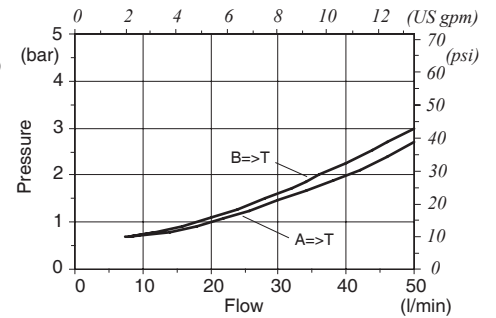

Type 8PF spool
 Double acting, 3 positions, regenerative circuit in 3rd position (pos. 2) with spool in

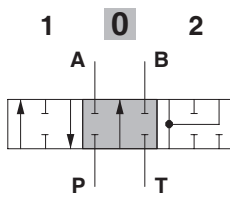

Spool stroke

- position 1: + 5.7 mm (+ 0.22 in)
- position 2: - 5.7 mm (- 0.22 in)

Spool metering

$Q_{in} = 160 \text{ l/min} / (42 \text{ US gpm})$
 $P_{(on ports)} = 100 \text{ bar} / (1450 \text{ psi})$

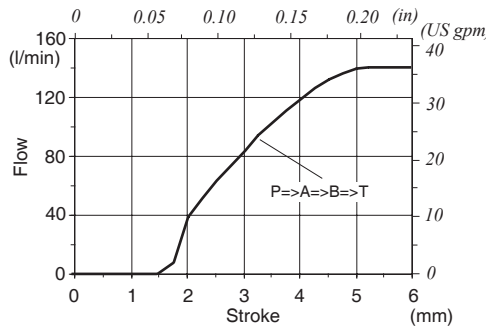

Pressure drop

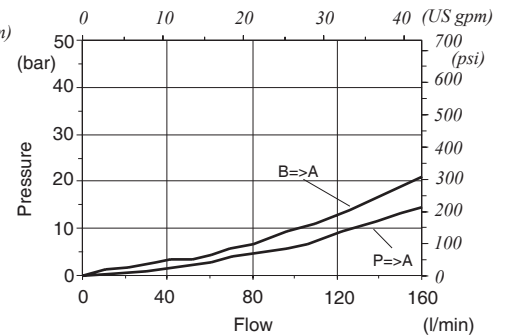

Type 8PFG spool
 Double acting, 3 positions, regenerative circuit in 2nd position (pos.1) with spool out

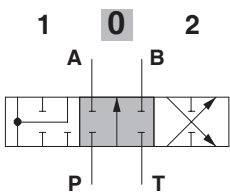

Spool stroke

- position 1: + 5.7 mm (+ 0.22 in)
- position 2: - 5.7 mm (- 0.22 in)

Type 1CSG (1CSGH) spool
 Double acting with A and B closed in neutral position, B partially connect to tank in pos. 1, A partially connect to tank in pos. 2

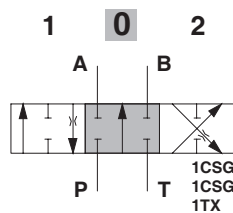

Spool stroke

- position 1: + 7 mm (+ 0.28 in)
- position 2: - 7 mm (- 0.28 in)

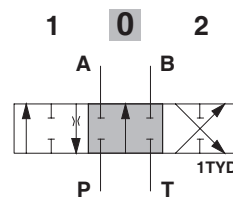

Spool stroke

- position 1: + 7 mm (+ 0.28 in)
- position 2: - 7 mm (- 0.28 in)

Type 1IMDA spool
 Double acting with A and B closed in neutral position, descent control and load check valve without power supply on port A

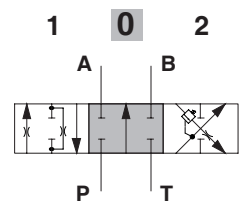

Spool stroke

- position 1: + 7 mm (+ 0.28 in)
- position 2: - 7 mm (- 0.28 in)

"A" side spool positioners

With spring return

8 type

It's supplied with standard spring D type (see force-stroke diagram) and available with lighter spring C type (**SMC** code: **5V08210000**).

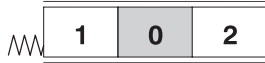

X = wrench 5 - 9.8 Nm (7.23 lbft)

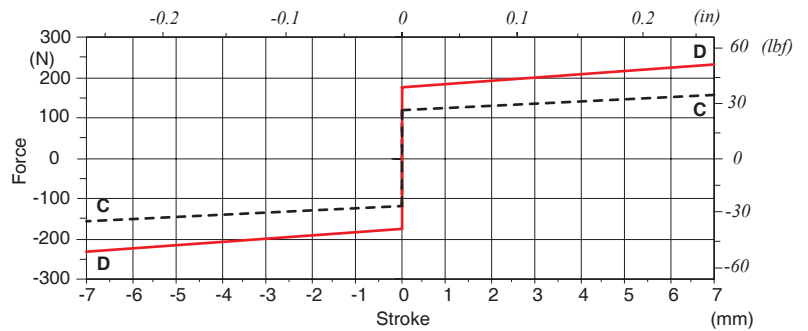
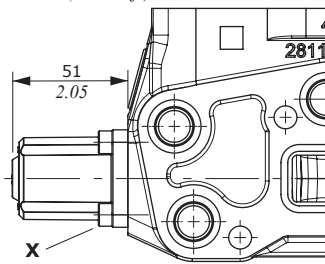

8TL type

As 8 type, for flexible cable control.

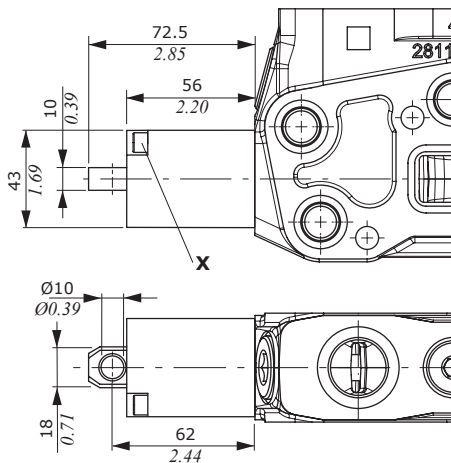

X = wrench 5 - 9.8 Nm (7.23 lbft)

8F2 type

With spool stroke adjustment in position 2 (P ⇒ B).

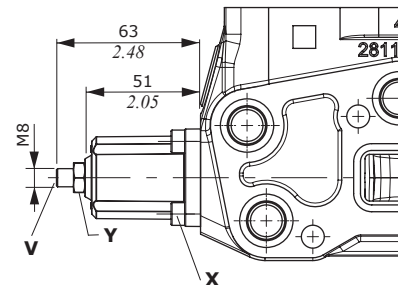

X = wrench 5 - 9.8 Nm (7.23 lbft)
Y = wrench 13 - 24 Nm (17.7 lbft)
Z = allen wrench 4

With detent

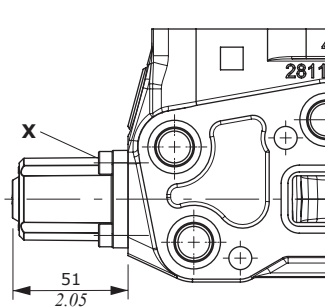

X = wrench 5 - 9.8 Nm (7.23 lbft)

11 type



15 type

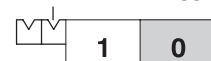

12 type



16 type



Features

Detent and release force : 280 N (63 lbf) ±10%

"A" side spool positioners

With detent and spring return to neutral position from either directions

9BZ type

detent in position 1 (curve A)



10BZ type

detent in position 2 (curve B)



11BZ type

detent in position 1 and 2 (curves A and B)

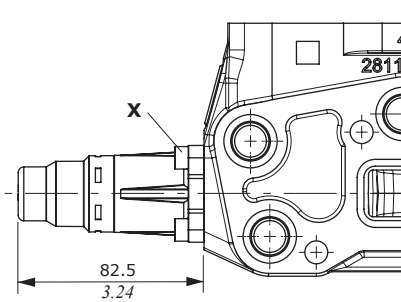

X = wrench 4 - 6.6 Nm (4.87 lbf)

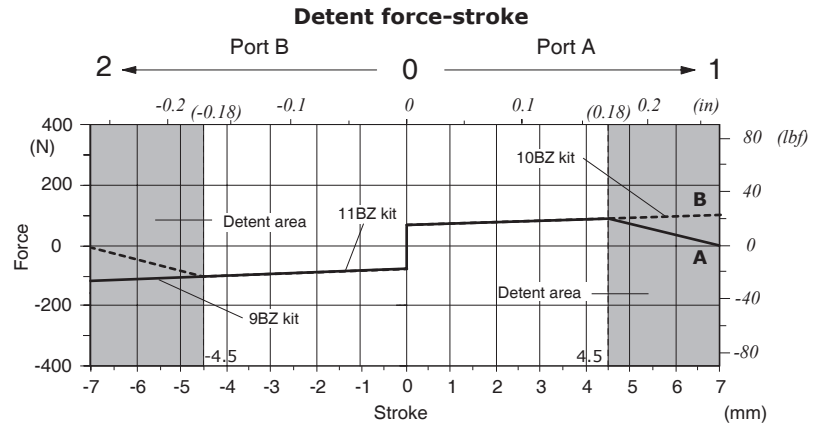

Position 1 - Detent force: 130 N (29.2 lbf) ± 10% / Release force: 215 N (48.3 lbf) ± 10%
Position 2 - Detent force: 145 N (32.6 lbf) ± 10% / Release force: 300 N (67.4 lbf) ± 10%

Solenoid lock device 8K type

With spring return and spool electromechanical lock in neutral position; when coil is fed the spool can be moved. it's possible to obtain further configurations with several "A" side spool positioners: contact Sales Dept.

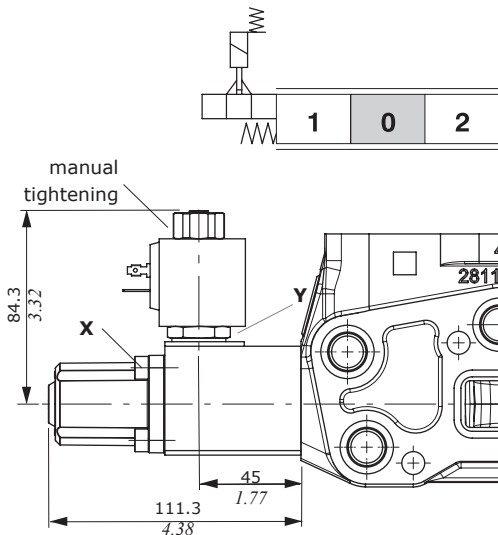

X = wrench 5 - 9.8 Nm (7.23 lbf)
 Y = wrench 24 - 24 Nm (17.7 lbf)

Features

For coil **BE** and mating connectors see page 76

"A" side spool positioners

ON/OFF pneumatic kit 8PG type

With spring return to neutral position. Needs dedicated working section kit **5EL1183000C**, **5EL216300E** or **5EL3183001A** (without spool seals).

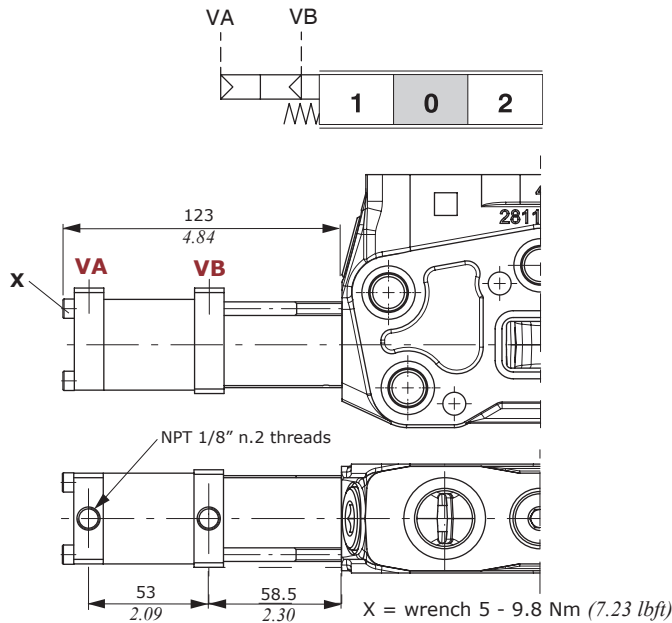

Features

Pilot pressure..... : min. 6 bar (87 psi)
: max. 12 bar (174 psi)

ON/OFF electro-pneumatic kit 8EPG3 type

Needs dedicated working section kit **5EL1183000C**, **5EL216300E** or **5EL3183001A** (without spool seals).

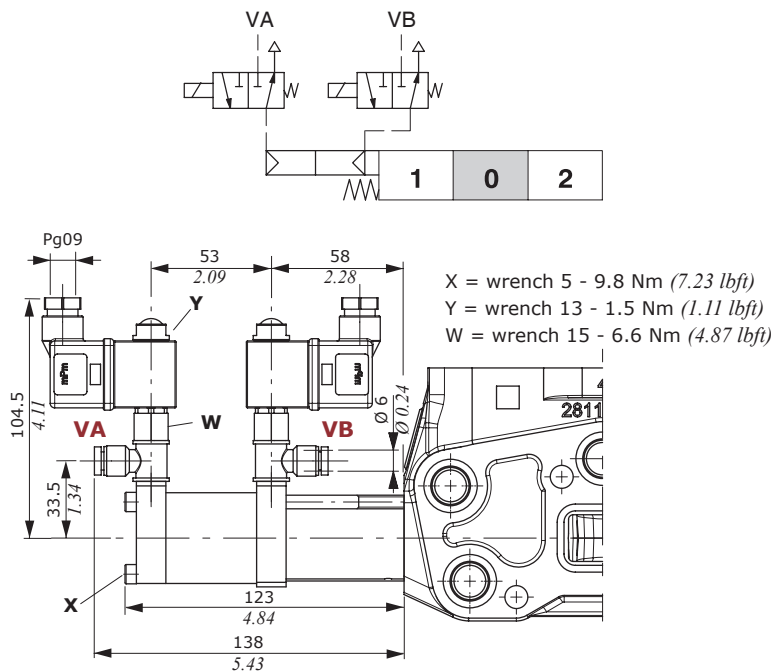

Features

Pilot pressure..... : min. 6 bar (85 psi)
: max. 15 bar (215 psi)

For coil **BPV** see page 78

“A” side spool positioners

ON/OFF pneumatic waterproof kit 8PDG type

Needs dedicated working section kit (without spool seals).

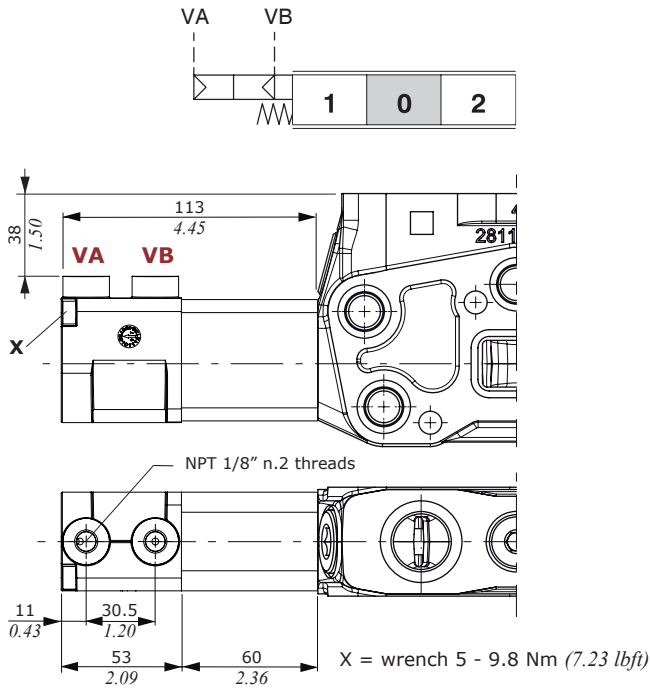

Features

Pilot pressure..... : min. 6.5 bar (90 psi)
: max. 15 bar (200 psi)

ON/OFF electro-pneumatic waterproof kit 8EPDG3 type

Needs dedicated working section kit (without spool seals).

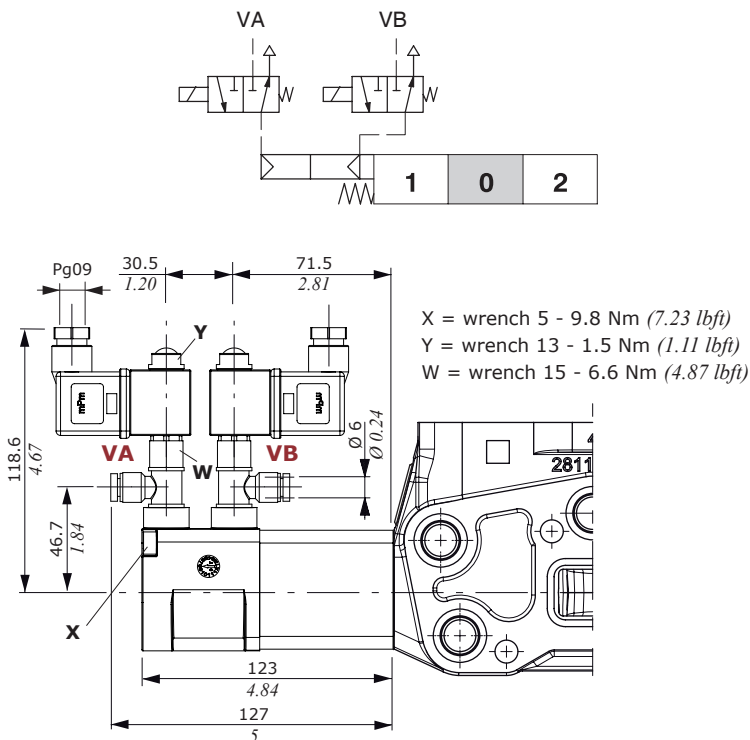

Features

Pilot pressure..... : min. 6.5 bar (90 psi)
: max. 15 bar (200 psi)

For coil **BPV** see page 78

"A" side spool positioners

ON/OFF electro-hydraulic control 8EI3

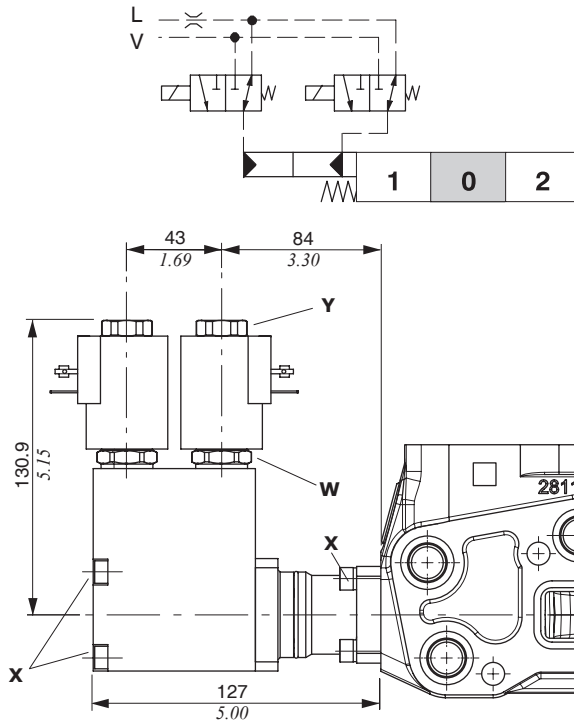

- X = wrench 5 - 9.8 Nm (7.23 lbf_t)
- Y = wrench 21 - 6.6 Nm (4.87 lbf_t)
- W = wrench 24 - 9.8 Nm (7.23 lbf_t)

Features

- Pilot pressure..... : min. 10 bar (145 psi)
: max. 50 bar (725 psi)
- Max backpressure on drain L... : 25 bar (360 psi)
- For coil BT and mating connectors see page 78

Collector kit for external pilot and drain

X = wrench 6 - 24 Nm (17.7 lbf_t)

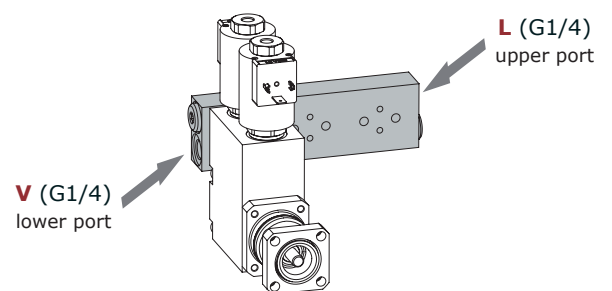
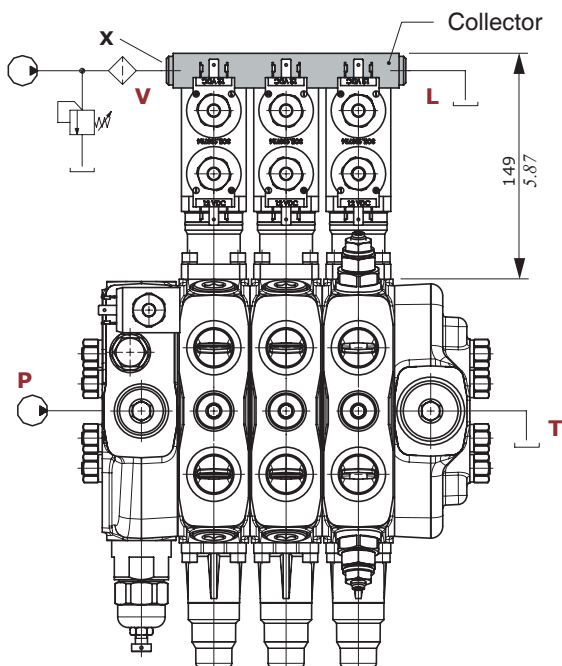

Description example:
SDS180/3/AC(XG-210)R2E/18EI3LCZ/18EI3LCZ/
18EI3LCZ.UX3(G-230)/RC-KE3S0-12VDC

COLLECTOR KIT CODES		
Type	Code *	Description
KE1S0	5KE1S00030	Kit for one section
KE2S0	5KE2S01530	Kit for 2 sections
KE3S0	5KE3S01530	Kit for 3 sections
KE4S0	5KE4S01530	Kit for 4 sections
KE5S0	5KE5S01530	Kit for 5 sections
KE6S0	5KE6S01530	Kit for 6 sections
KE7S0	5KE7S01530	Kit for 7 sections

(*) codes are referred to BSP thread

"A" side spool positioners

ON/OFF electro-hydraulic kit 8EI3 type

Collector kit for internal pilot and drain

The kit include collector, VRP pressure reducing valve and pipes.

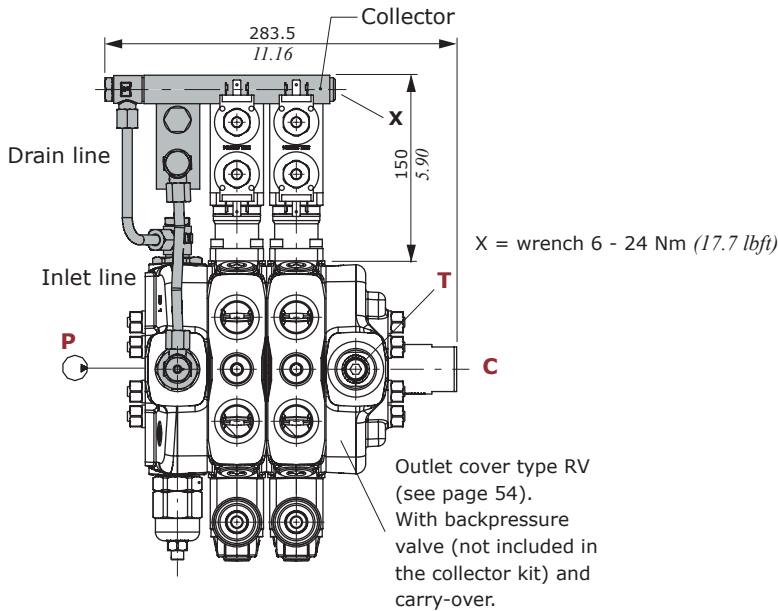

COLLECTOR KIT CODES		
Type	Code *	Description
KE1R3	5KE1R31530	Kit for one section
KE2R3	5KE2R31530	Kit for 2 sections
KE3R3	5KE3R31530	Kit for 3 sections
KE4R3	5KE4R31530	Kit for 4 sections
KE5R3	5KE5R31530	Kit for 5 sections
KE6R3	5KE6R31530	Kit for 6 sections
KE7R3	5KE7R31530	Kit for 7 sections

(*) codes are referred to BSP thread

Description example:
 SDS180/2/AC(YG3-120)/1CS8EI3L/1CS8EI3L/
RV-KE2R3-24VDC

Features

VRP VALVE

- Output pressure. : 20 bar (290 psi)
- Max flow : 8 l/min (2.1 US gpm)
- Filtering : 80 µm

VRE backpressure valve

Valve assembled on flow through passage to provide pilot pressure to the actuator.

It's available as **VRE** (code X076700010) for inlet flow lower 80 l/min (21.13 US gpm) or **VRE(6)** (code X076710006) for inlet flow upper 80 l/min (21.13 US gpm): see diagram.

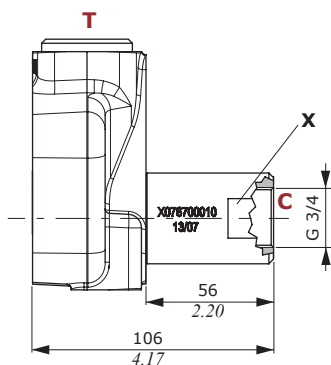

X = wrench 36 - 42 Nm (31 lbft)

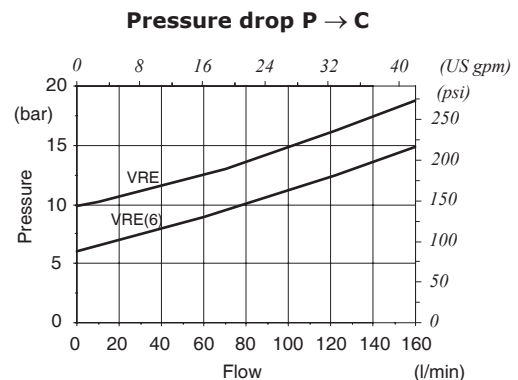

"A" side spool positioners

Particular positioner kits for special spools

11A

With detent in position 1 and 2, and automatic release in neutral position.

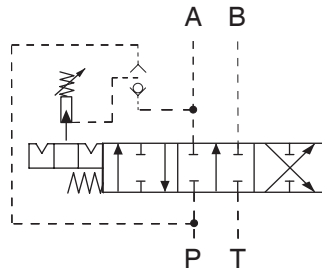

- X = wrench 5 - 9.8 Nm (7.23 lbf·ft)
- Y = wrench 10 - 9.8 Nm (7.23 lbf·ft)
- V = wrench 24 - 9.8 Nm (7.23 lbf·ft)
- W = allen wrench 3

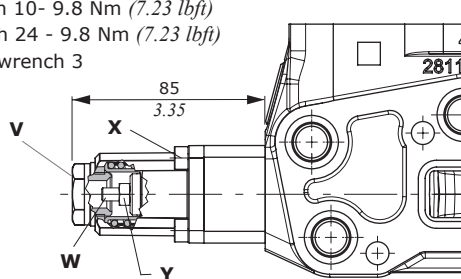

Dedicated parts	Type	Code
Spool	1(11A)	3CU2510321
Working section kit	P	5EL1183000C

Features

Release pressure : from 20 to 180 bar
(from 290 to 2600 psi)

13MD

Detent in 4th position with spring return in neutral position with detent spool in type.

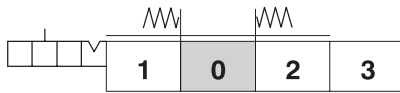

- X = wrench 5 - 9.8 Nm (7.23 lbf·ft)

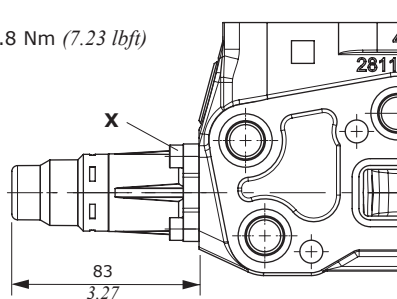

Dedicated parts	Type	Code
Spool	5	3CU2541200
Working section kit left inlet	P5	5EL1183201
Working section kit right inlet	P5ED	5EL1183260

13C

Detent in 4th position with spring return in neutral position with detent spool out type.



- X = wrench 5 - 9.8 Nm (7.23 lbf·ft)

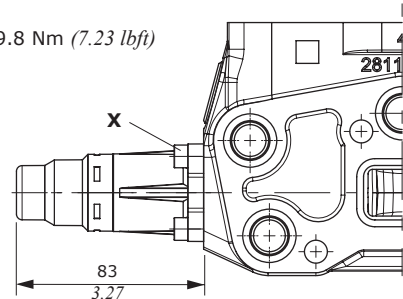

Dedicated parts	Type	Code
Spool	5B	3CU2541203-H
Working section kit left inlet	P5ED	5EL1183260
Working section kit right inlet	P5	5EL1183201

"B" side options

Lever control

L type

Alluminium lever pivot box with protective rubber bellow; it can be roated 180° (configuration **L180**).

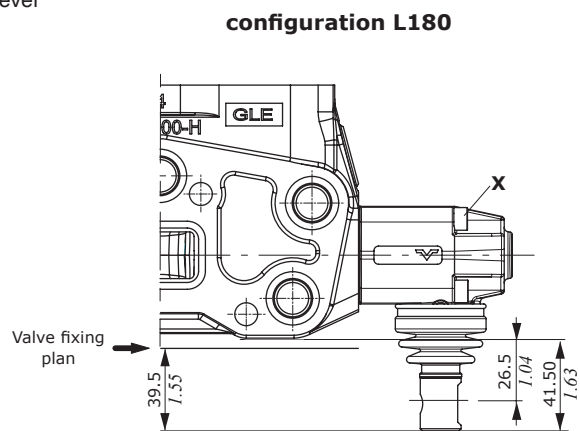
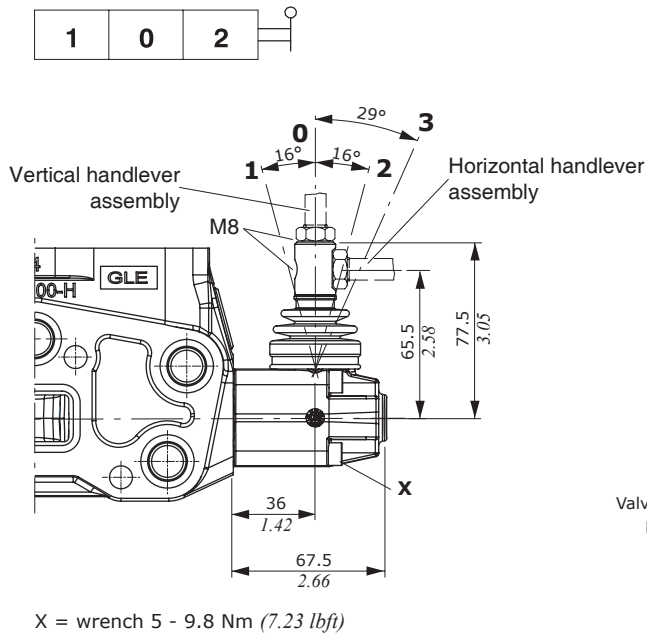

LF1 type

With spool stroke adjustment in position 12 (P→A). It can be roated 180° (configuration **LF1180**).

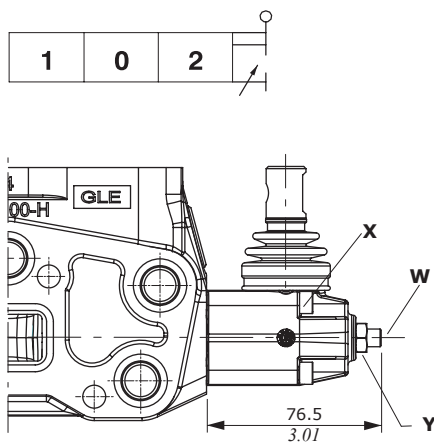

X = wrench 5 - 9.8 Nm (7.23 lbft)
 Y = wrench 13 - 24 Nm (17.7 lbft)
 W = allen wrench 4

LB type

Steel construction, with pivot placed down. Assembling with 5B and 5BY type spool is not possible.

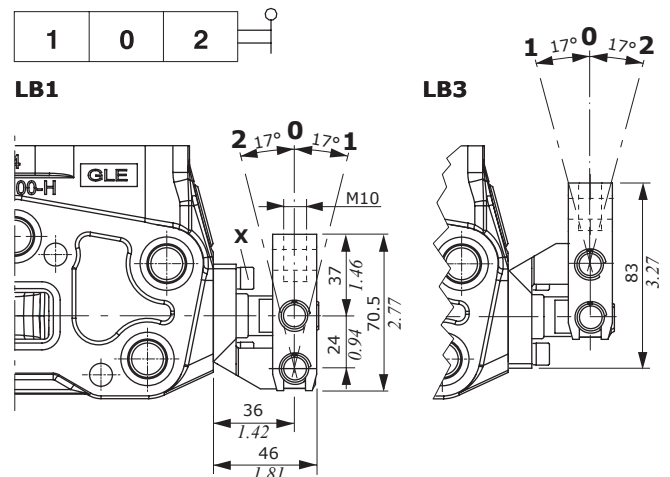

X = wrench 5 - 9.8 Nm (7.23 lbft)

LCB and LCE mechanical joysticks for two sections control

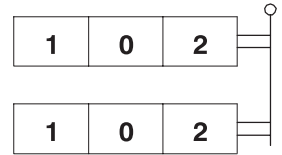
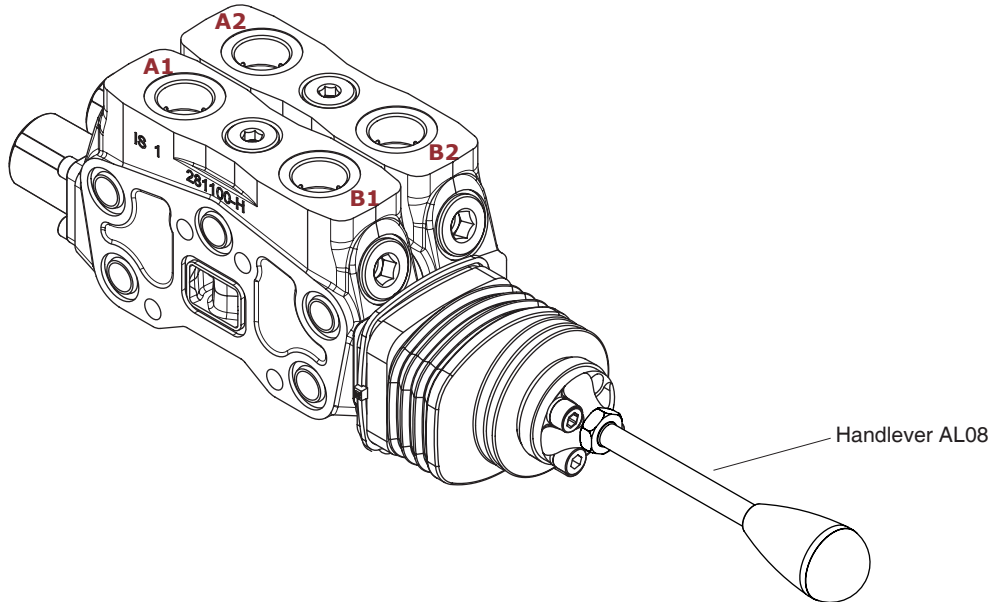

NOTE – The handlever must be ordered separately (see page 28).

Dimensions and movement scheme for left inlet directional valve

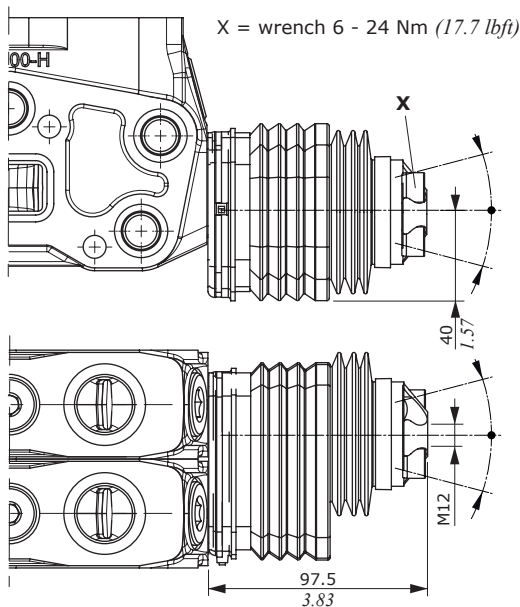

Execution **LCB1**
pivot placed down on the left

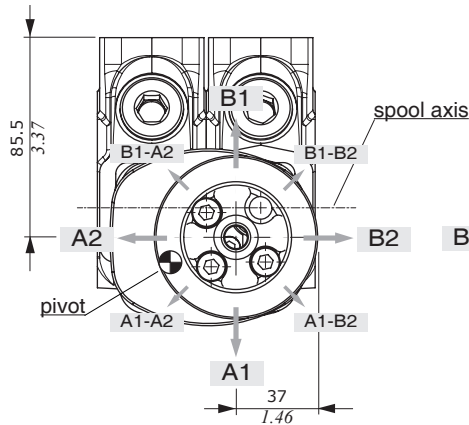

Execution **LCB2**
pivot placed down on the right

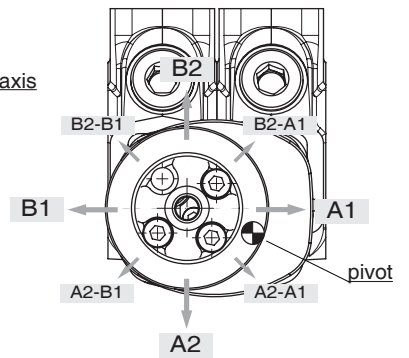

Execution **LCB3**
pivot placed above to the left

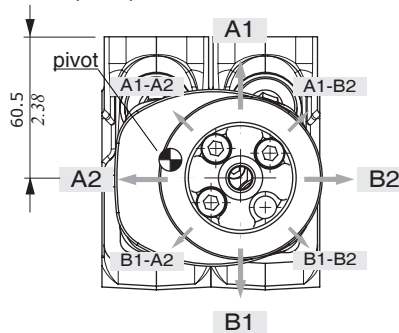

Execution **LCB4**
pivot placed above to the right

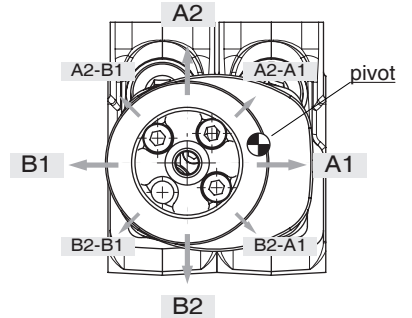

Max. working angles	Horizontal axis	Vertical axis
Single action operation	18°30'	15°30'
Single action operation with floating	not available	not available
Two section operation	18°30'	15°30'
Two section operation with floating	not available	not available

"B" side options

SL type

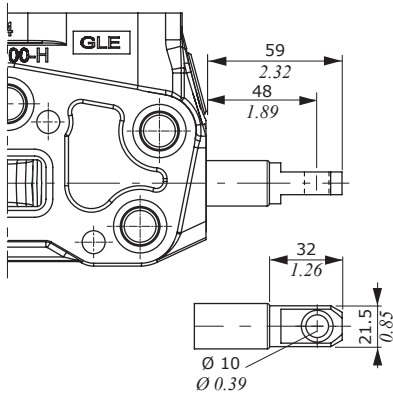

SLP type

Mechanical control with dust-proof plate kit.

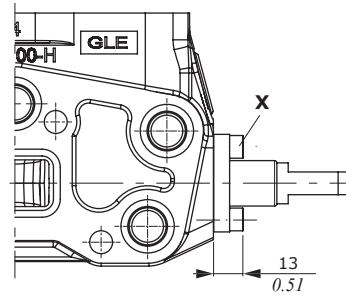

X = wrench 5 - 9.8 Nm (7.23 lbft)

TQ cable remote control kit

Prearranged for remote control with flexible cable.

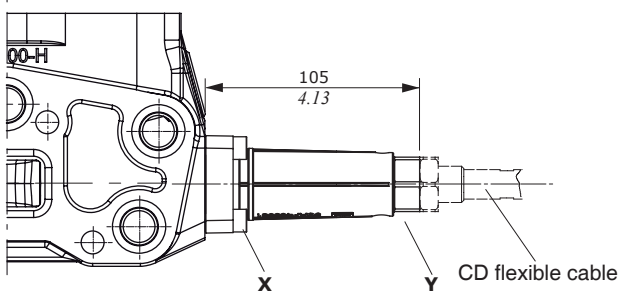
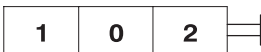

X = wrench 5 - 9.8 Nm (7.23 lbft)

Y = allen wrench 24

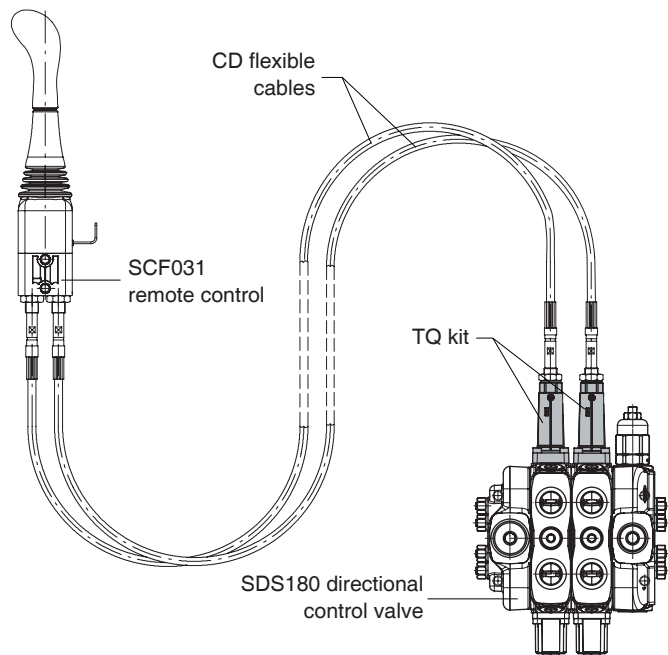

NOTE - For more information about remote cable control, require appropriate documentation.

Proportional hydraulic controls

Needs dedicated spool and working section kit without spool seals. (See page 31).

8IM type

Zama control kit.

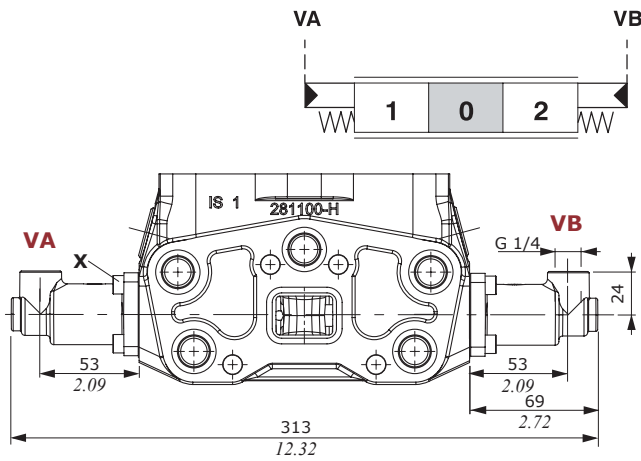

8IMF3 type

Zama control kit, configuration with screws for spool stroke adjustment.

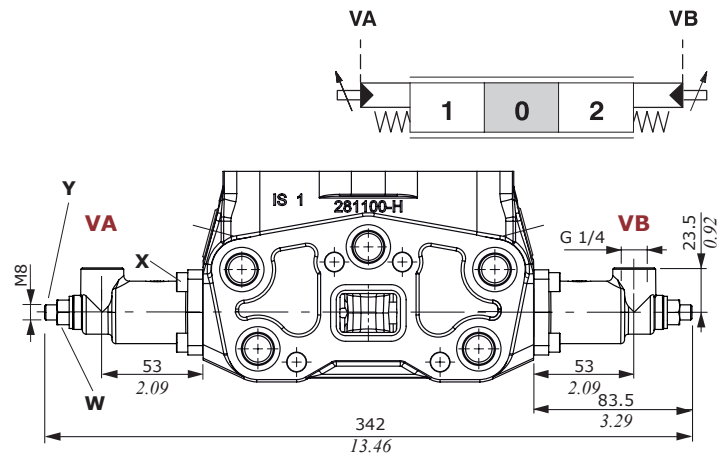

8IMOH type

Steel control kit.

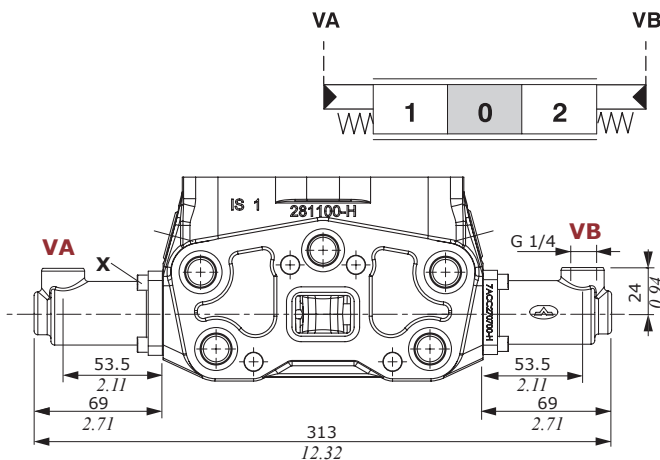

X = wrench 5 - 9.8 Nm (7.23 lbft)

Y = allen wrench 4

W = wrench 13 - 24 Nm (17.7 lbft)

8IM type features

Adjustment range : from 5.8 to 19 bar
(from 84.1 to 275 psi)

Pilot pressure : max. 100 bar (1450 psi)

8IMF3 type and 8IMOH type features

Adjustment range : Da 5 a 20 bar
(from 72.5 to 290 psi)

Pilot pressure : max. 100 bar (1450 psi)

NOTE – these drawings are not to scale with the others included in the catalog

Diagrams and features of proportional hydraulic controls

Pressure - stroke diagram
(for controls represented)

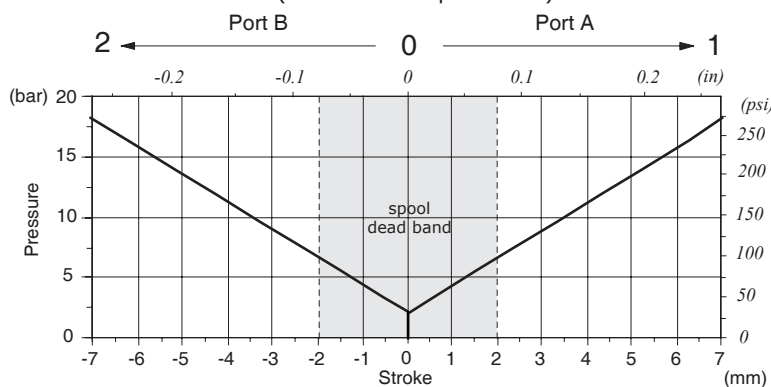

Pressure control curve on port VA and VB: type 033

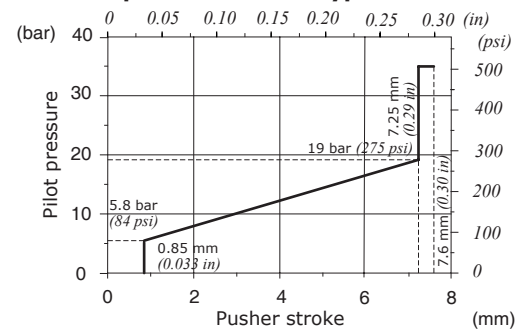

Features

Pilot pressure : max. 100 bar (1450 psi)

Complete controls

Proportional hydraulic control

8IMSPSL proportional hydraulic kit

With spool position sensor.

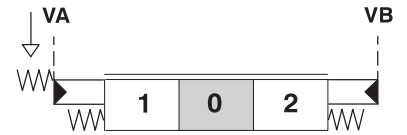
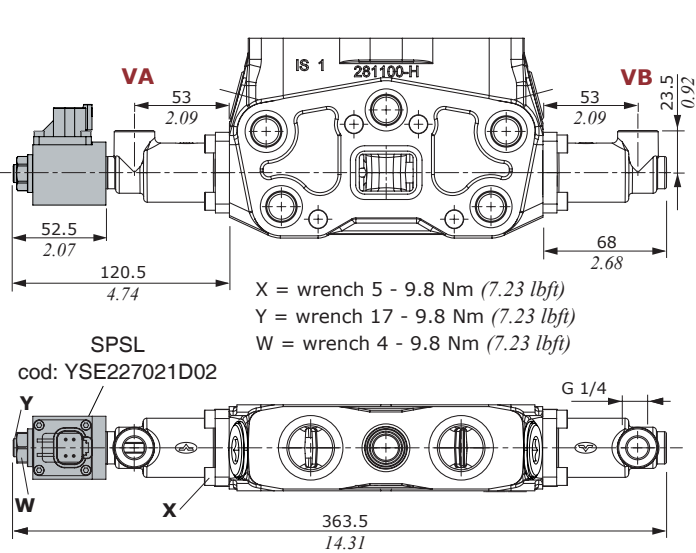

Control features

- Pilot pressure : max. 100 bar (1450 psi)
- Connector : Deutsch DT04-4P
- Mating connector cod. 5CON140072 not included

Spool position sensor features

- Voltage supply range : from 9 to 32 VDC or 5 VDC
- Current absorption : <10 mA
- Mechanical life : 3x10⁶
- Connector type : Deutsch DT04-4P
- Weather protection : IP 67 - IP 69K
- Working temperature : -40/+105 °C
- Minimum load resistance. : 10 KΩ
- Working pressure max. : 350 bar • 5100 psi
- Max. mechanical stroke : ±10 mm
- Max. electrical stroke. : ±10mm
- Output signal
 - Range : from 0.5 to 4.5 V
 - Linearity : ± 5%
 - Spool in neutral : 2.5 ± 0.2 V
 - Max current. : 1 mA
- Mechanical vibrations, shock, bumps : IEC 68-2-6,27,29
- EMC compatibility. : ISO 13766 - ISO 15982

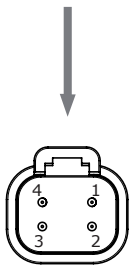

Pin	Connector PIN-OUT Functions	
	for 5V supply	for 8-32V supply
1	+5V	signal OUT
2	N.C.	GND
3	GND	Vb+
4	signal Out	not connected

NOTE - these drawings are not to scale with the others included in the catalog

Output Voltage-spool stroke diagram

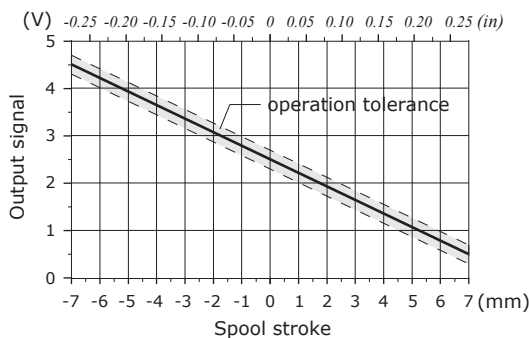

Proportional hydraulic control

8IMD proportional hydraulic kit

For descent control valve on A.

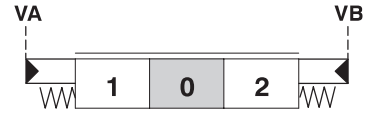
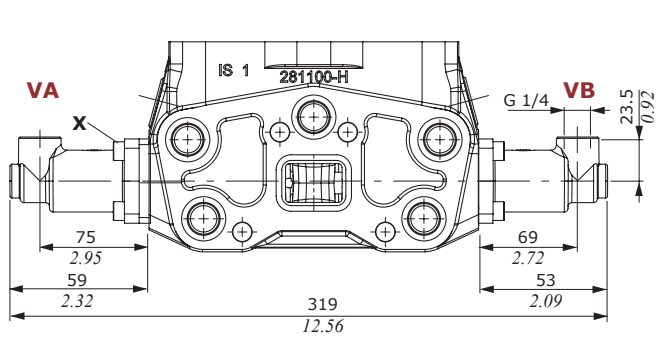

Dedicated parts	Type	Code
Spool	1MDA	3CU2510490
Working section kit	PHD/IM	5EL1183020A

Features

Pilot pressure : max. 100 bar (1450 psi)

X = wrench 5 - 9.8 Nm (7.23 lbf_t)

NOTE - these drawings are not to scale with the others included in the catalog

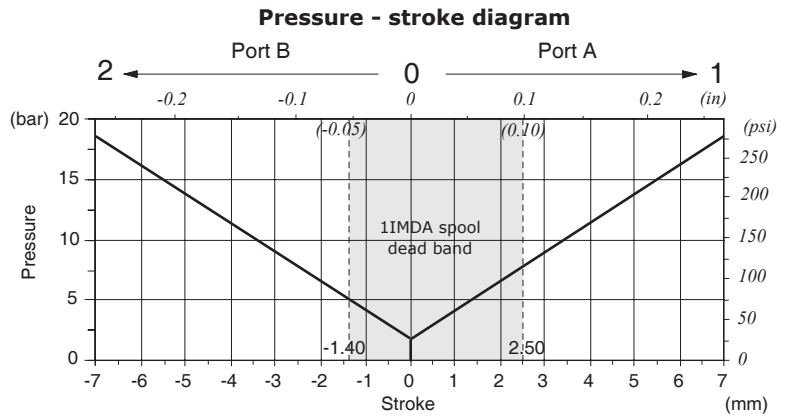
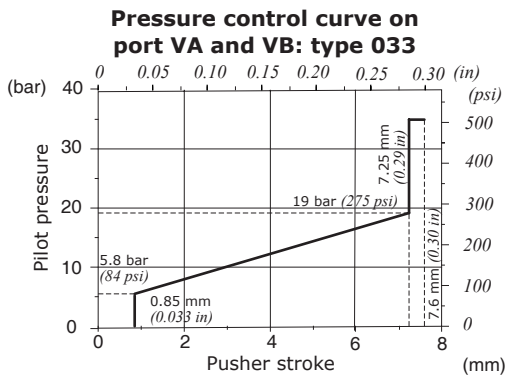

Complete controls

Proportional hydraulic control

13IMP and 13IMOPHCR proportional hydraulic kit

For floating circuit.

13IMP

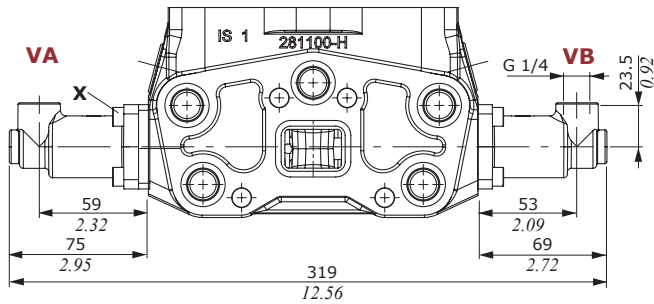

X = wrench 5 - 9.8 Nm (7.23 lbft)

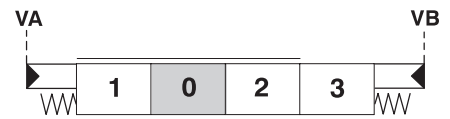

13IMOPHCR

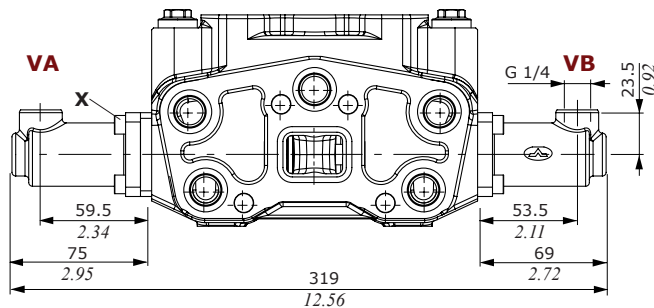

NOTE - these drawings are not to scale with the others included in the catalog

Dedicated parts		13 IMP	
	Type	Code	
Spool	5IMP	3CU2542430	
Working section kit	P5/IMP	5EL1183205A	

Dedicated parts		13IMOPHCR	
	Type	Code	
Spool	5HFLIM	3CU2541210-H	
Working section kit	RPH5LL/IM	5EL1183065A-H	

Features

Pilot pressure : max. 100 bar (1450 psi)

Pressure control curve on port VA and VB: type 075

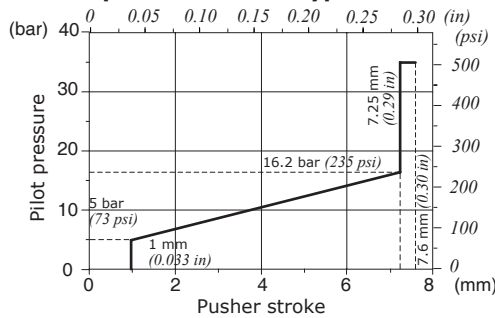

Pressure - stroke diagram

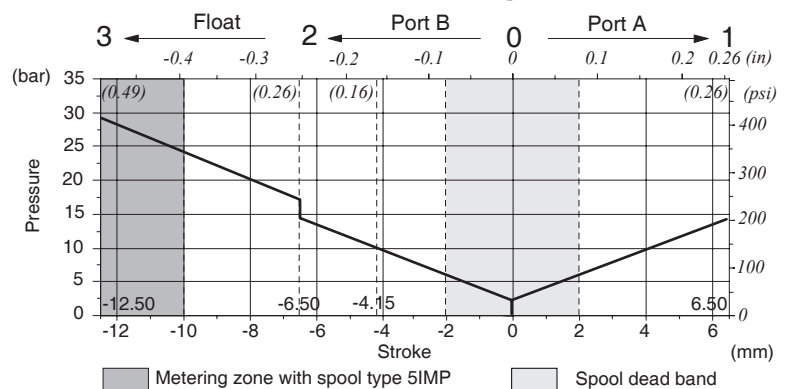

Antishock valves

P 1 (G 3 - 100)

- Valve setting (bar)
- Spring type
- Configuration

- 1 mounted on port A
- 2 mounted on port B
- 3 mounted on ports A and B

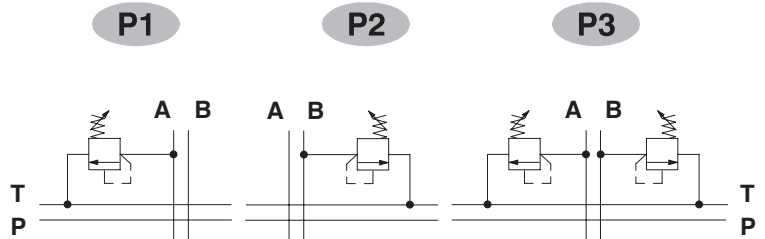

Configuration type G:
with screw

Configuration type H:
valve set and locked

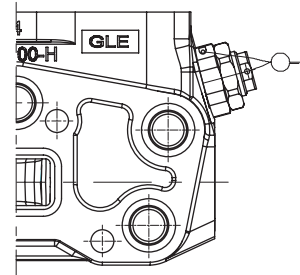
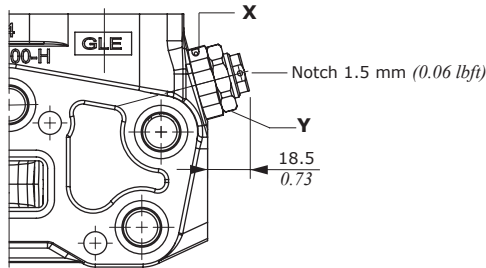

X = wrench 30 - 42 Nm (31 lbf)
Y = wrench 27 - 24 Nm (17.7 lbf)

G2 setting range

From 50 to 120 bar (from 725 to 1750 psi)

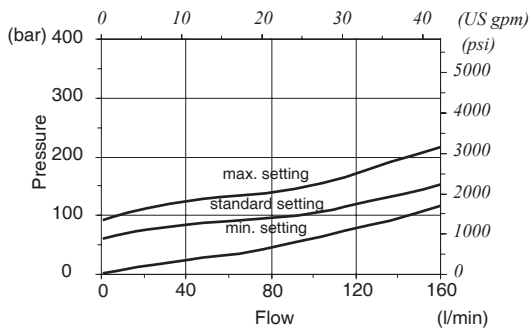

G3 setting range

From 100 to 250 bar (from 1450 to 3600 psi)

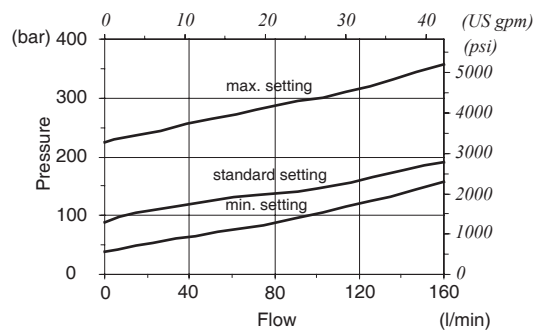

G4 setting range

From 160 to 315 bar (from 2300 to 4600 psi)

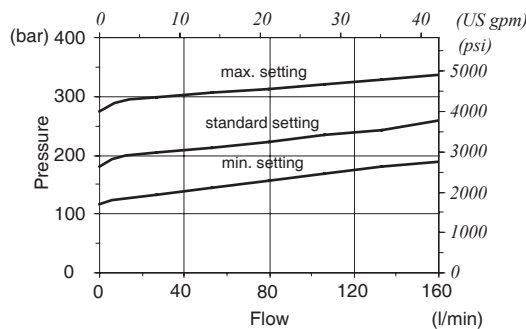

Port valves

Antishock and anticavitation valves

U 1 (G 3 - 100)

Valve setting (bar)
Spring type
Configuration

- 1 mounted on port A
- 2 mounted on port B
- 3 mounted on ports A and B

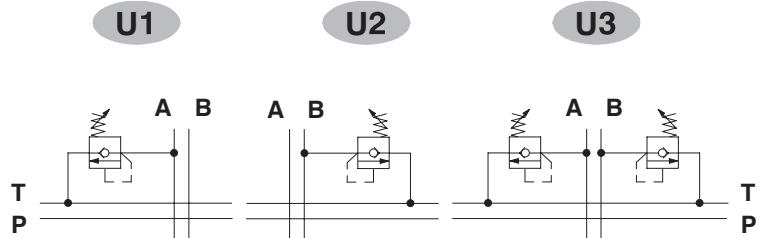

Configuration type G:
with screw

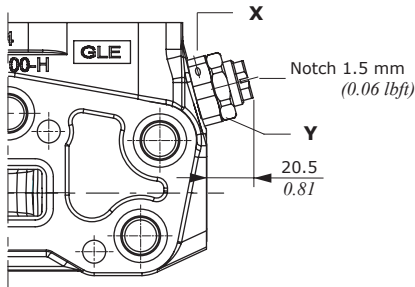

X = wrench 30 - 42 Nm (31 lbf)
Y = wrench 27 - 24 Nm (17.7 lbf)

Configuration type H:
valve set and locked

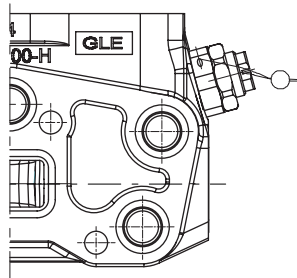

Configuration type Z:
with tamper proof
cap

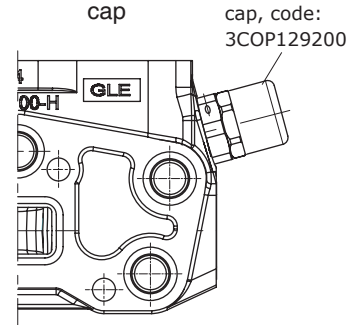

G2 setting range

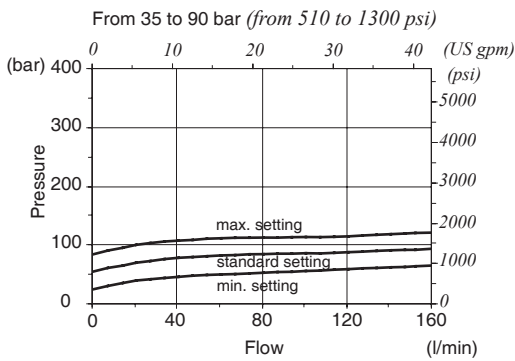

G3 setting range

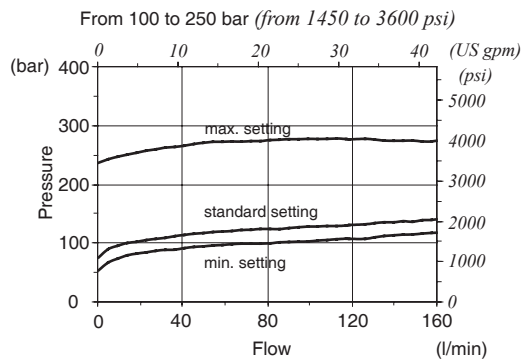

G4 setting range

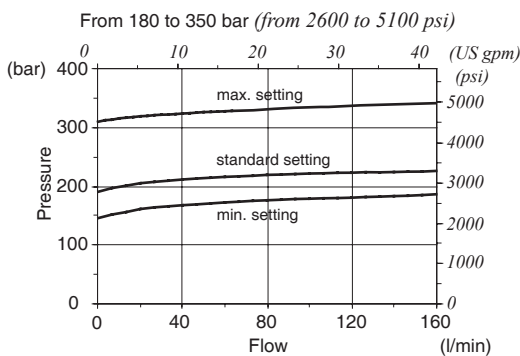

Pressure drop P ⇒ T

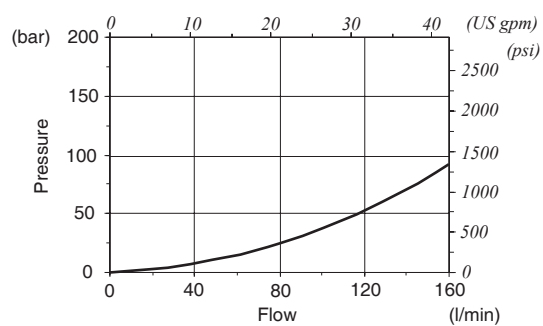

Pilot operated anti-shock and anticavitation valves

UXW 1 (G - 160)

- Pressure setting (bar)
- Configuration
- 1 mounted on port A
- 2 mounted on port B
- 3 mounted on ports A and B

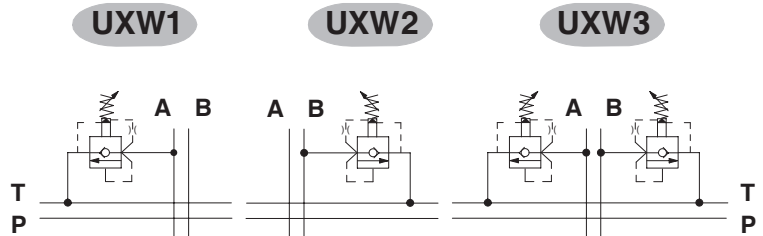

Configuration type G: with screw

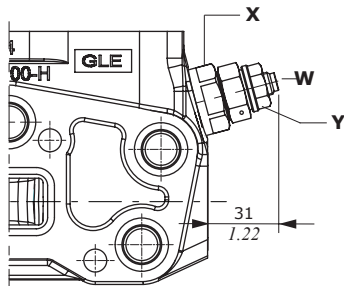

- X = wrench 27 - 42 Nm (31 lbft)
- Y = wrench 17 - 24 Nm (17.7 lbft)
- W = allen wrench 5

Configuration type H: valve set and locked

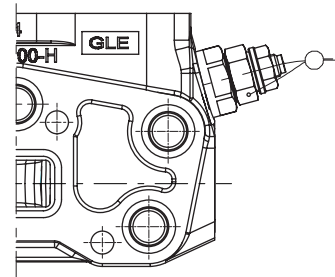

Range setting

From 63 to 315 bar (from 900 to 4600 psi)

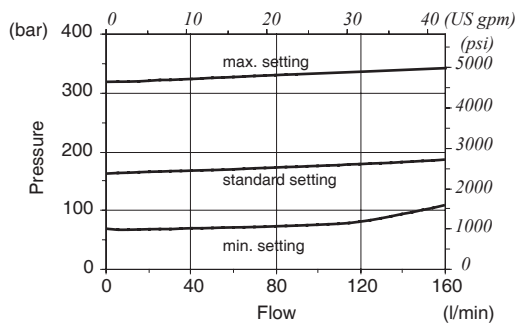

Pressure drop

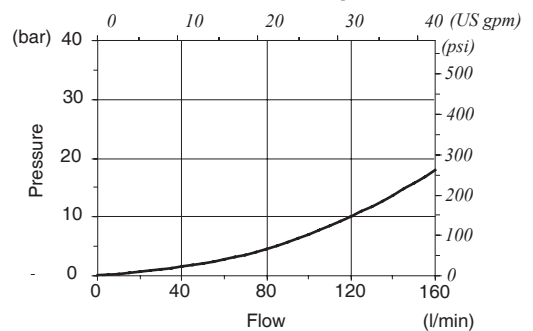

Port valves

Pilot hydraulic unloader valve

PX 1

- 1 mounted on port A
- 2 mounted on port B
- 3 mounted on ports A and B

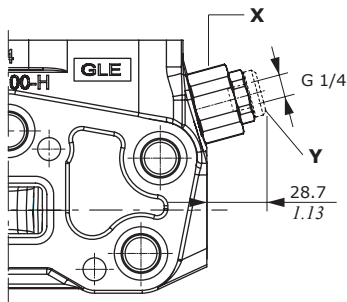
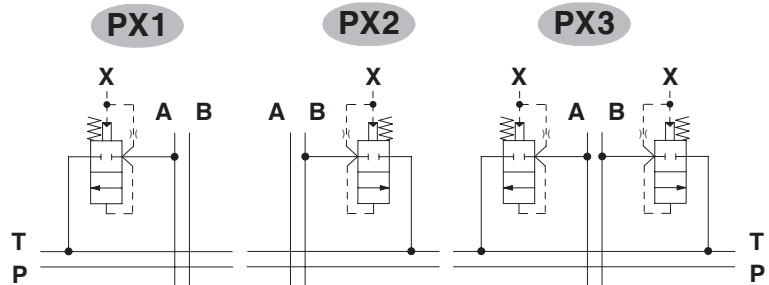

X = wrench 30 - 42 Nm (31 lbft)
 Y = wrench 6 - 24 Nm (17.7 lbft)

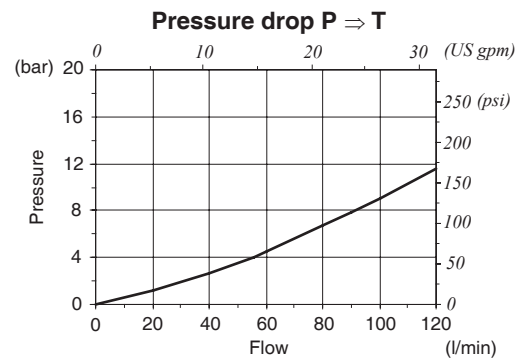

NOTE – For safety reasons the valve is supplied with blanking plug

Anticavitation valve

C 1

- 1 mounted on port A
- 2 mounted on port B
- 3 mounted on ports A and B

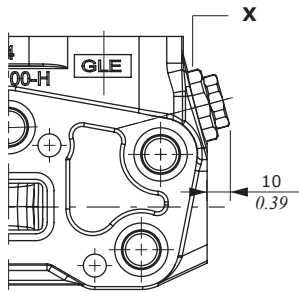

X = wrench 30 - 42 Nm (31 lbft)

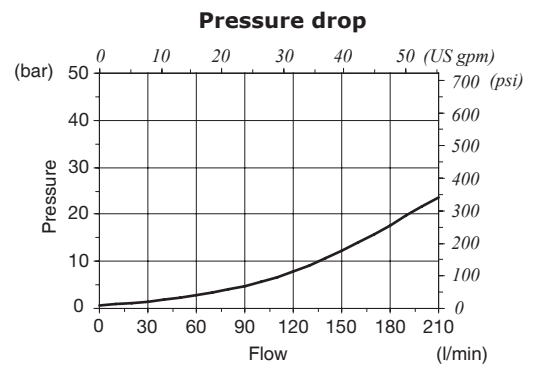
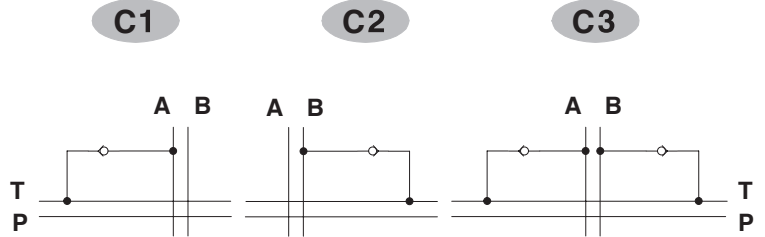

Valve blanking plug

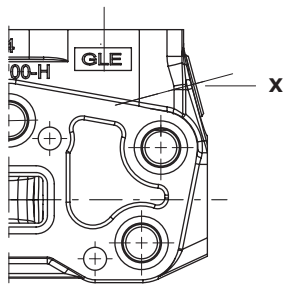

X = wrench 12 - 42 Nm (31 lbft)

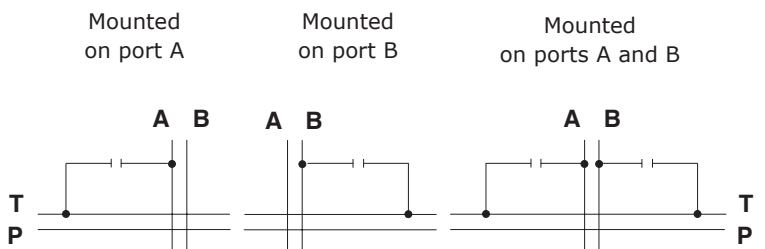

Port valves

Low leak valve

For RPH5LL working port.

X = wrench 8 - 24 Nm (17.7 lbft)

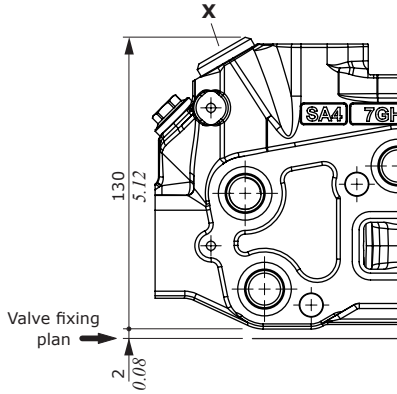

Features

Oil leakage : 3-4 cm³/min (0.18-0.24 in³/min)
 With mineral oil of 46mm²/s (46 cSt) viscosity at 40°C (104°F) temperature

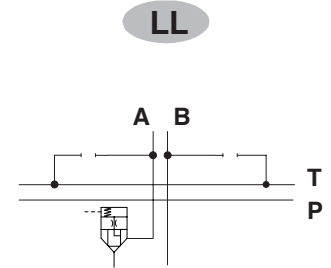

Fixed setting antishock and anticavitation valves

For RPH5LL, RPHT, RPH5, RPHSP, RSP5 working port.

U 1 (100)

Valve setting (bar)

- 1 mounted on port A
- 2 mounted on port B
- 3 mounted on ports A and B

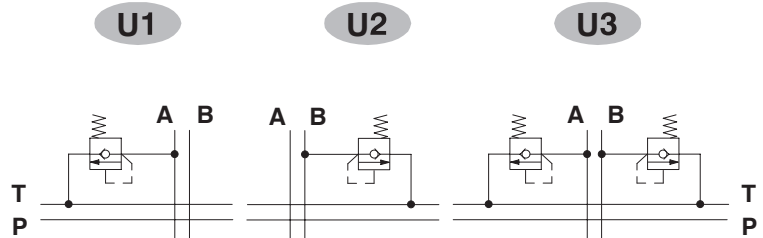

X = wrench 13 - 24 Nm (17.7 lbft)

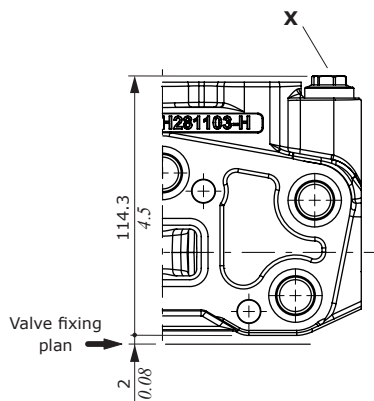

Setting example (10 l/min - 2.6 Us gpm)

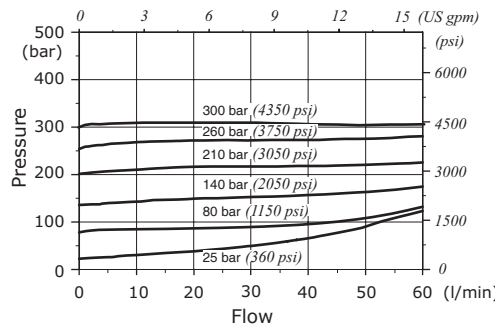

Pressure drop (in anticavitation)

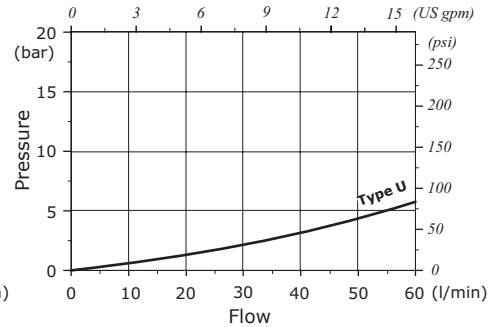

Anticavitation valve

For RPH5LL, RPHT, RPH5, RPHSP, RSP5 working port.

C 1

- 1 mounted on port A
- 2 mounted on port B
- 3 mounted on ports A and B

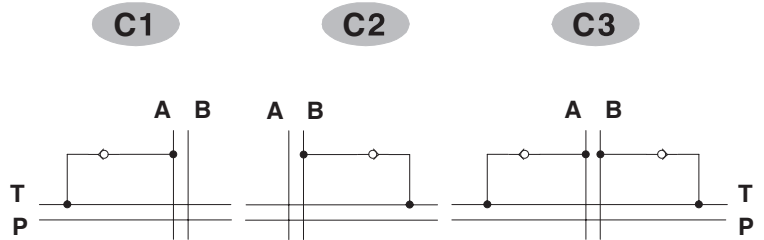

X = wrench 13 - 24 Nm (17.7 lbf)

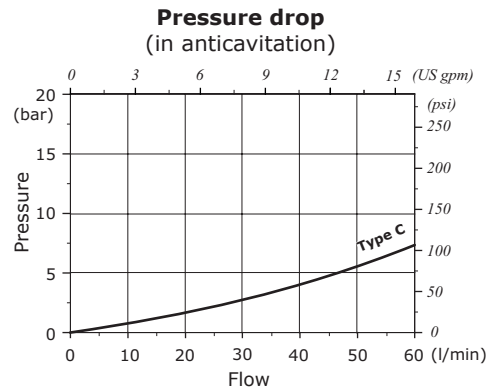
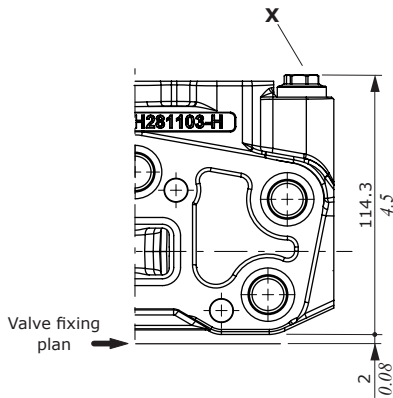

Valve blanking plug

UT 3

- 1 mounted on port A
- 2 mounted on port B
- 3 mounted on ports A and B

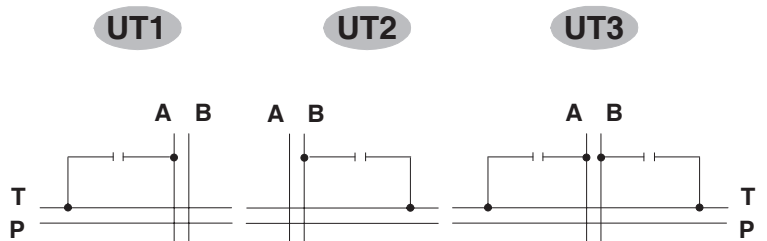

X = wrench 13 - 24 Nm (17.7 lbf)

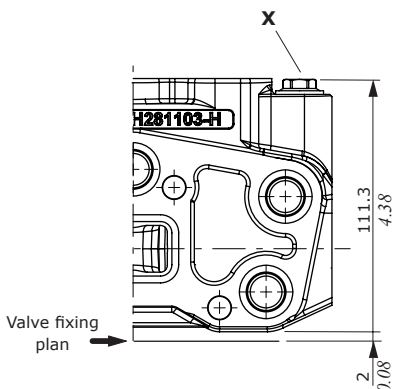

CS1 mid return manifold

Mid return manifolds for directional valve with left and right inlet both; they allow 2 independent circuits with common outlet.

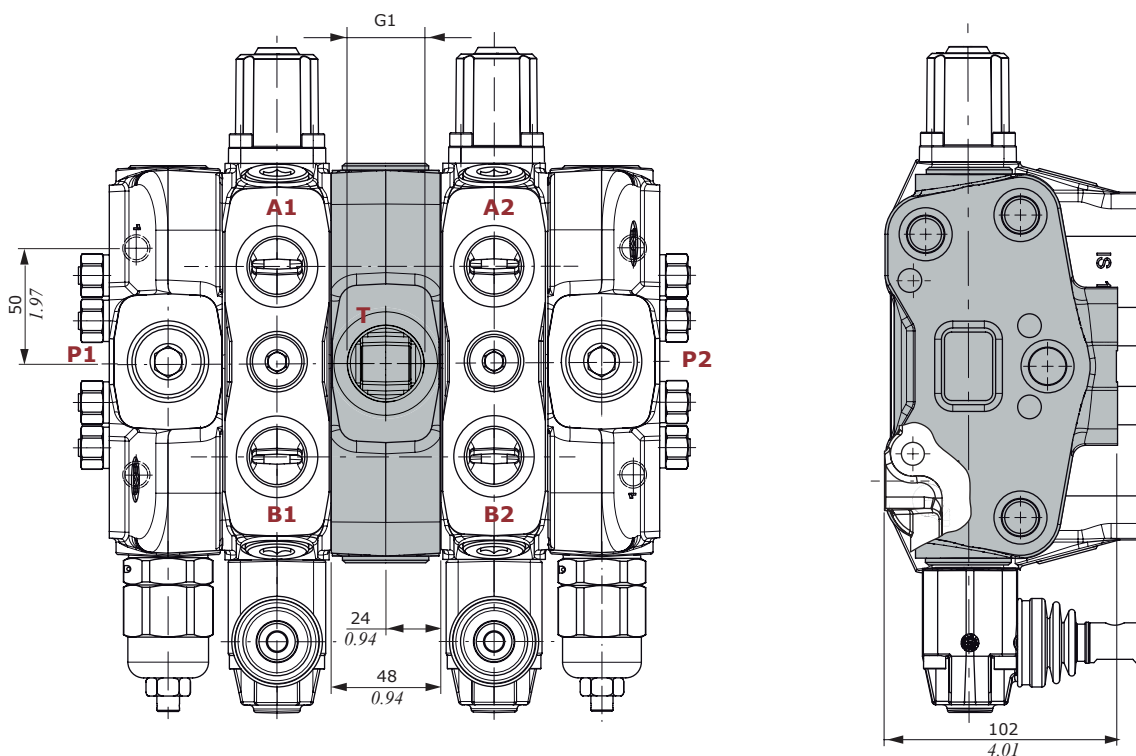

Hydraulic circuit

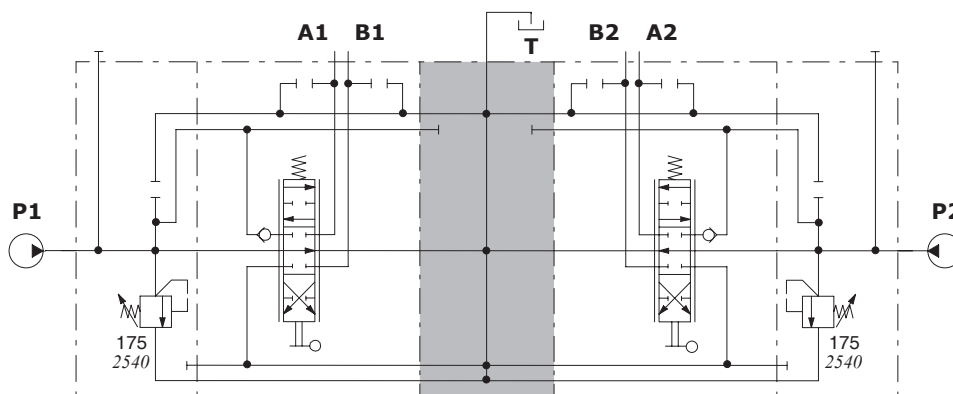

Description example:

SDS180/2/AC(YG3-175)/18L/CS1/ 18L/BC(YG3-175)

CS3 mid return manifold

Mid return manifolds for directional valves SDS180 with left inlet section and SDS150 with right inlet section; they allow 2 independent circuits with common outlet.

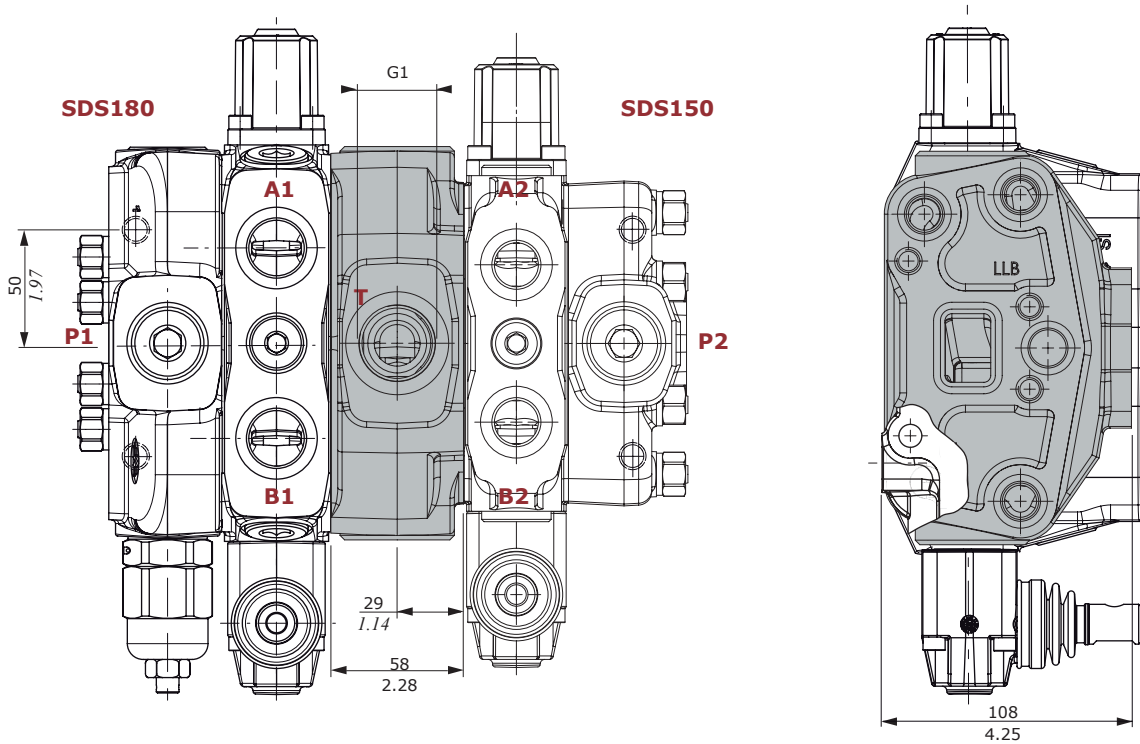

Hydraulic circuit

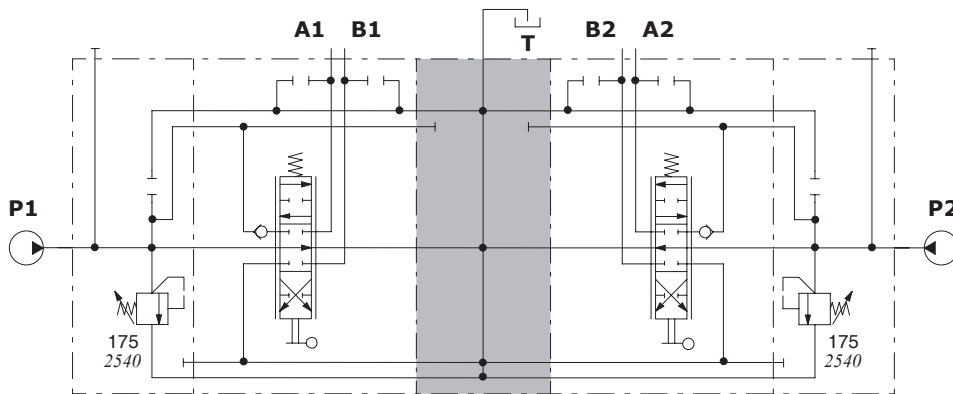

Description example:

SDS180/1/AC(YG3-175)/18L/CS3/18L/BC(YG3-175)/SDS150/1

Service relief valve section

EI configuration

The operation of up stream section exclude the EI downstream section.

The pressure of the downstream sections should be adjusted at least 20 bar below the relief valve setting.

Execution EI2, without plug, is prearranged for a second inlet.

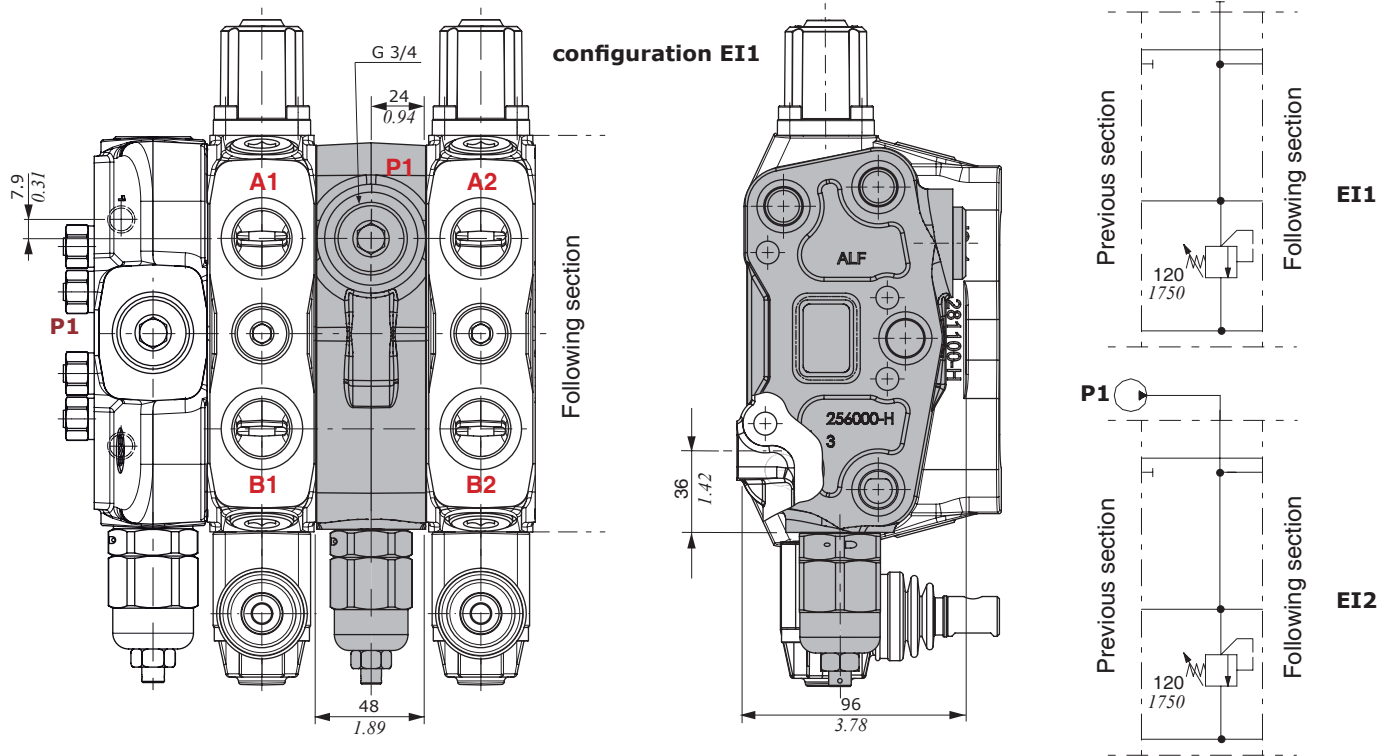

EIM configuration

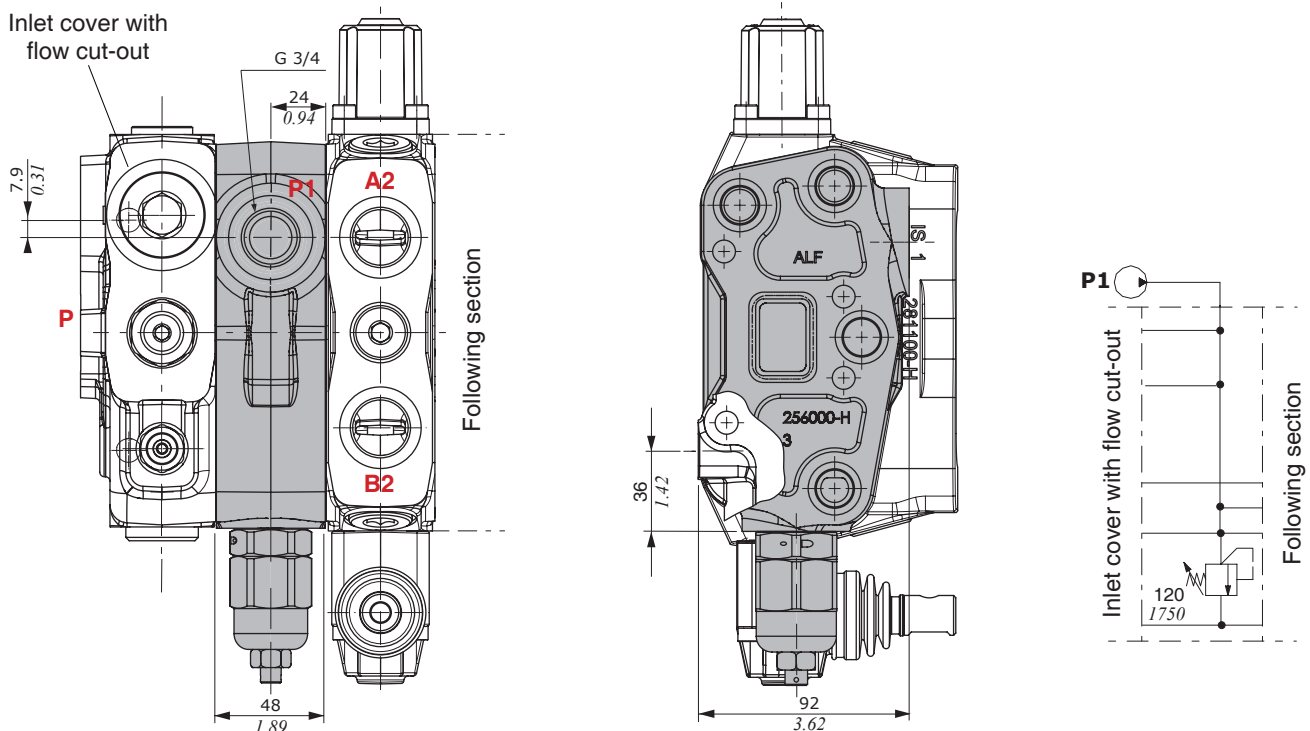

NOTE – EIM intermediate section must be always assembled with inlet cover with flow cut-out. (See page 20).

FS SDS180 / RC

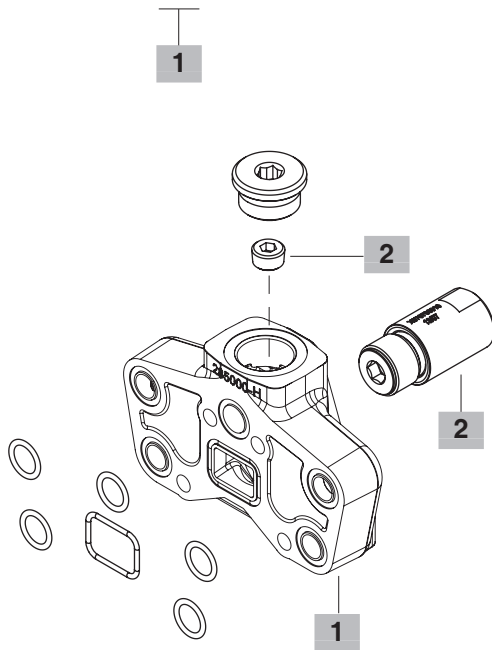

1 Complete outlet cover

TYPE	CODE	DESCRIPTION
RC	618301003	With side outlet
RD	618301002	With upper outlet
RE	618301001	With upper outlet and side carry-over sleeve
RK	618301004	With upper outlet and closed center
RV	618301009	With backpressure valve

2 Circuit options

TYPE	CODE	QTY	DESCRIPTION
-	4TAP318010	1	M18x1.5 tapered plug for carry-over (RE), carry-over with backpressure valve (RV) and closed centre (RK) options
VRE(6)	X076710006	1	Backpressure valve 6 bar (87 psi) for RV configuration
VRE	X076700010	1	Backpressure valve 10 bar (145 psi) for RV configuration
-	3XTAP740210	1	G1 plug

Dimensional data and hydraulic circuit

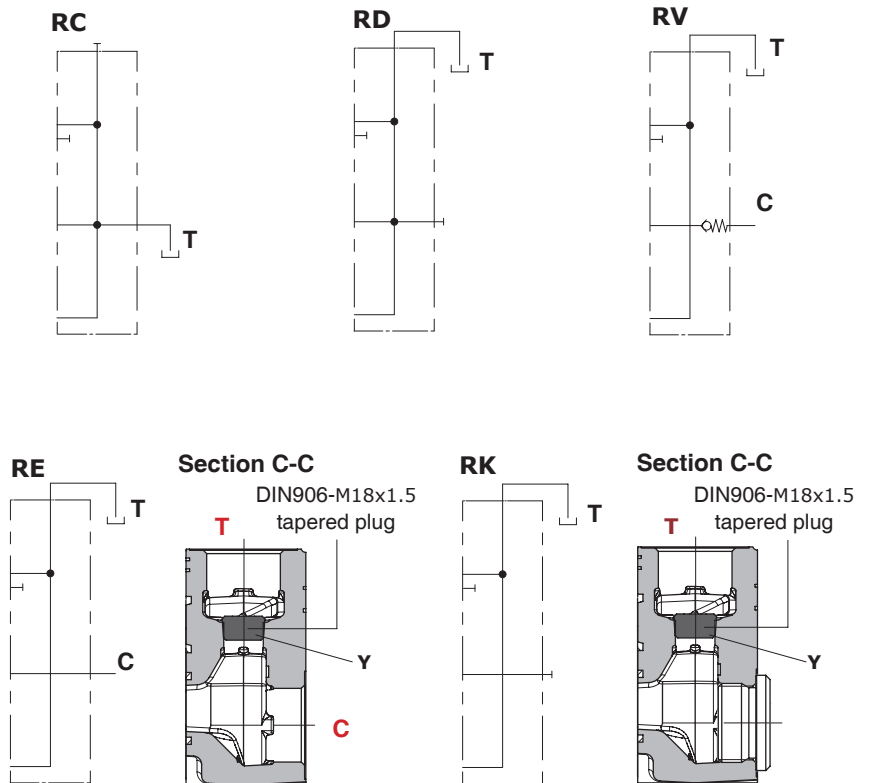
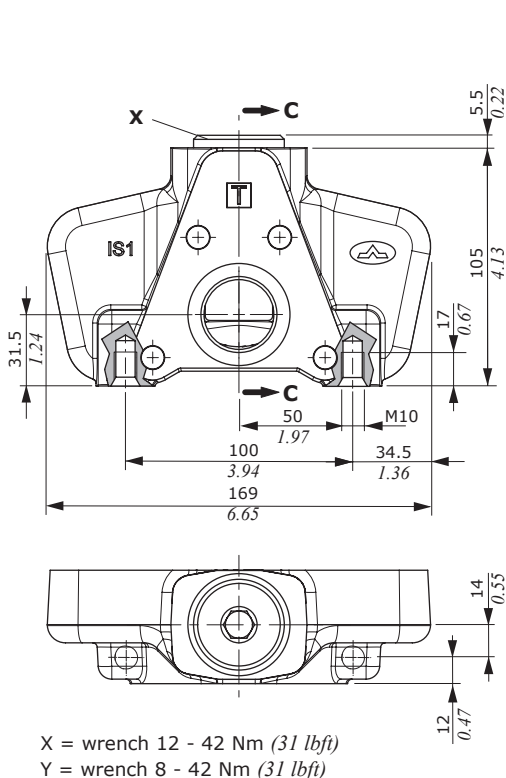

Installation and maintenance

The SDS180 and DLS180 valves are assembled and tested as per the technical specification of this catalogue.

Before the final installation on your equipment, follow the below recommendations:

- the valve can be assembled in any position; order to prevent working section deformation and spool sticking mount the product on a flat surface;
- In order to prevent the possibility of water entering the lever box and spool control kit, do not use high pressure wash down directly on the valve;
- prior to painting, ensure plastic port plugs are tightly in place.

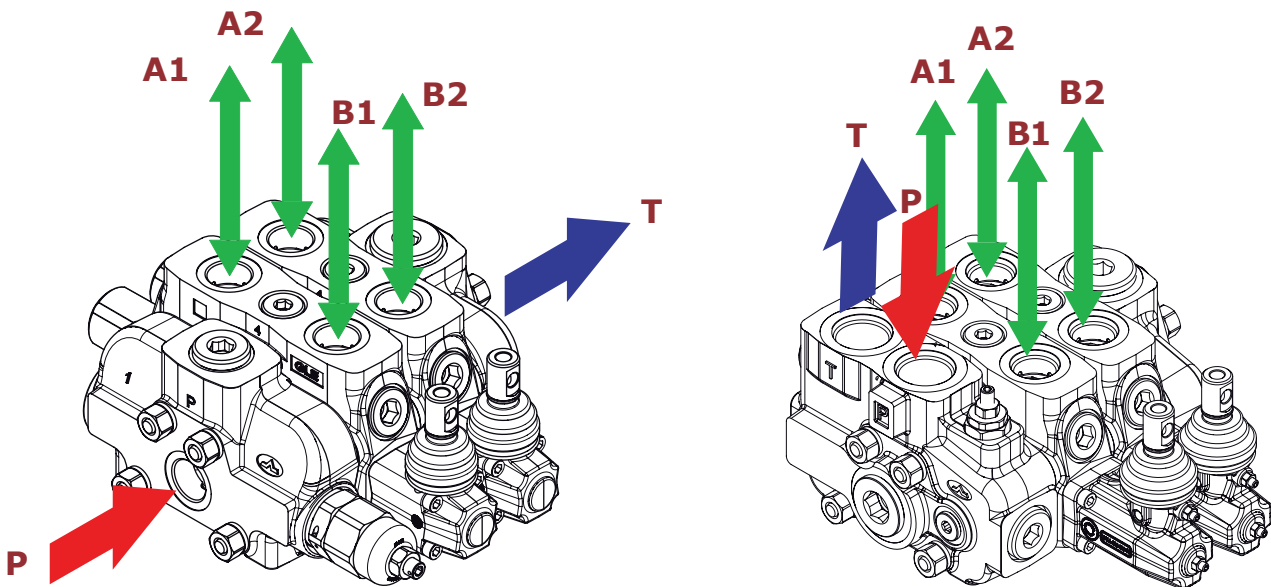

Fitting tightening torque - Nm (lbft)				
THREAD TYPE	port P	ports A, B	port T	Hydraulic pilot
BSP	G 3/4	G 3/4	G 1	G 1/4
With O-Ring seal	90 (66.4)	90 (66.4)	100 (73.7)	25 (18.4)
With copper washer	90 (66.4)	90 (66.4)	90 (66.4)	30 (22.1)
With steel and rubber washer	70 (51.6)	70 (51.6)	100 (73.7)	16 (11.8)
UN-UNF	1 5/16-12 (SAE 16)	1 1/16-12 (SAE 12)	1 5/16-12 (SAE 16)	9/16-18 (SAE 6)
With O-Ring seal	150 (110.6)	95 (70.1)	150 (110.6)	30 (22.1)

NOTE - These torque are recommended. Assembly tightening torque depends on many factors, including lubrication, coating and surface finish. The manufacturer shall be consulted.

Coils

Types and ordering codes

Coil type	Voltage	Connectors					
		ISO4400	Deutsch DT	AMP JPT	Packard Weatherpack	Packard Metri-pack	Flying leads (without conn.)
BER	10 VDC	4SLE001000	-	-	-	-	-
	12 VDC	4SLE001200	4SLE001201 ⁽⁵⁾	4SLE001203 ⁽⁵⁾	4SLE001210 ⁽²⁾	4SLE001214 ⁽²⁾	4SLE001207
		4SLE001217 ⁽³⁾	4SLE001209 ⁽³⁻⁵⁾	4SLE001211 ⁽³⁻⁵⁾	-	-	-
		4SLE002400	4SLE001202 ⁽⁶⁾	4SLE001206 ⁽³⁻⁶⁾	-	-	-
		4SLE002408 ⁽³⁾	4SLE001216 ⁽³⁻⁶⁾	4SLE002401 ⁽⁵⁾	4SLE002403 ⁽⁵⁾	-	4SLE002404
	4SLE302400 ⁽¹⁾	4SLE002407 ⁽³⁻⁵⁾	4SLE002402 ⁽⁶⁾	-	-	-	
48 VDC	4SLE004800	-	-	-	-	-	
110VDC	4SLE011000	-	-	-	-	-	
220 VDC	4SLE022000	-	-	-	-	-	
	4SLE322000 ⁽¹⁾	-	-	-	-	-	
BE	12 VDC	4SL1000120	4SL1000123 ⁽⁶⁾	-	-	-	4SL1000122
	24 VDC	4SL1000240	4SL1000140 ⁽³⁻⁶⁾	-	-	-	-
		4SL1030240 ⁽¹⁾	4SL1000124 ⁽²⁾	4SL1002401 ⁽⁶⁾	-	-	-
	110 VDC	4SL1011100	-	-	-	-	-
220 VDC	4SL1022200	-	-	-	-	-	
	4SL1032200 ⁽¹⁾	-	-	-	-	-	
BT	10 VDC	4SL3000100	-	-	-	-	-
	12 VDC	4SL3000120	4SL3000130 ⁽⁶⁾	4SL3000122 ⁽⁵⁾	4SL3000124 ⁽²⁾	4SL3000127 ⁽²⁾	4SL300012C
		4SL3000126 ⁽⁴⁾	4SL3000134 ⁽³⁻⁶⁾	4SL30001200 ⁽³⁻⁵⁾	-	-	-
		4SL3000240	4SL3000128 ⁽²⁾	4SL3000248 ⁽⁵⁾	-	-	4SL3000246
	26 VDC	4SL3000260	-	-	-	-	-
	48 VDC	4SL3000480	-	-	-	-	-
110 VDC	4SL3001100	-	-	-	-	-	
220 VDC	4SL3002200	-	-	-	-	-	
	4SL3032200 ⁽¹⁾	-	-	-	-	-	
BPV	12 VDC	4SLA001200	-	-	-	-	-
	24 VDC	4SLA002400	-	-	-	-	-
Mating connectors (For connector with rectifier see following table)		4CN1009995	5CON140031	5CON003	5CON001	5CON017	-

NOTES - ⁽¹⁾ supply with AC and use only with rectifier connector - ⁽²⁾ with flying leads - ⁽³⁾ with bidirectional diode - ⁽⁵⁾ with unidirectional diode ⁽⁵⁾ integrated perpendicular type - ⁽⁶⁾ integrated parallel type

Voltage	ISO 4400 mating connector with rectifier			
	BER type coil	BT type coil	BPV type coil	BE type coil
24 VDC	4CN1010240	4CN3010240	-	4CN1010240
48 VDC	4CN1010480	4CN3010480	-	4CN1010480
110 VDC	4CN1011100	4CN3011100	-	4CN1011100
220 VDC	4CN1012200	4CN3012200	-	4CN1012200

Fixing brackets

They are available for SDS180/DLS180 directional valves and they are zinc plated steel, complete with mounting screws.

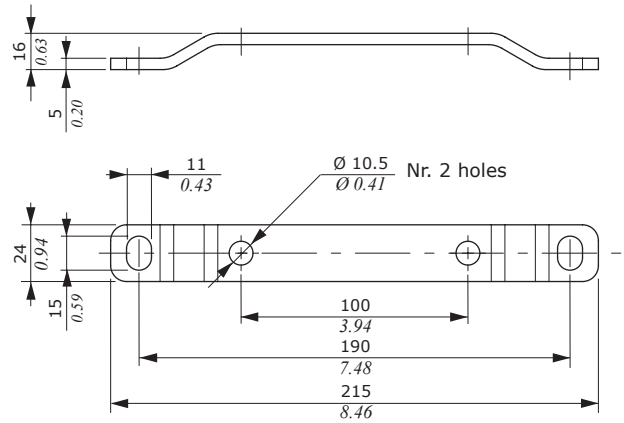
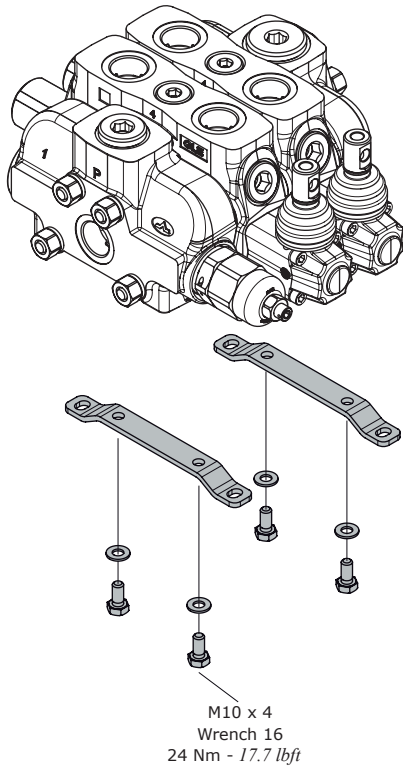

Painting

SDS180 valve can be supplied with one coat of black paint (**CVN** configuration).

Description example: SDS180/2/AC(YG3-120)/18L/18L/RC-**<CVN>**

NOTES - For different colour consult Sales Department.

8th edition June 2015

WWW.WALVOIL.COM



D1WWEB01E

