

SDS400

Sectional directional control valve

Features

Sectional directional control valve for high flow, available for fixed displacements hydraulic pumps.

- From 1 to 10 work sections
- Open centre
- Optional carry-over port
- Main pilot relief valve on inlet cover and load check valve on every section
- Available wide range of port valves
- Available manual and hydraulic control kits
- Diameter 30 mm (1.18 in) interchangeable spools

Additional information

This catalogue shows the product in the most standard configurations.
Please contact our Sales Dpt. for more detailed information or special requests.

WARNING!

All specifications of this catalogue refer to the standard product at this date.
Walvoil, oriented to a continuous improvement, reserves the right to discontinue, modify or revise the specifications without notice.

WALVOIL IS NOT RESPONSIBLE FOR ANY DAMAGE CAUSED BY AN INCORRECT USE OF THE PRODUCT.

7th edition October 2014

SDS400

- Valve general information
 - Working conditions page 4
 - Standard threads page 4
 - Dimensional data page 5
 - Performance data page 5
 - Hydraulic circuit page 6
 - Complete sections ordering codes page 8
- Inlet section
 - Parts ordering codes page 10
 - Dimensional data and hydraulic circuit page 11
 - Inlet relief options. page 12
- Working section
 - Parts ordering codes (mechanical control) page 14
 - Parts ordering codes (prop. hydraulic control) page 16
 - Dimensional data and hydraulic circuit page 17
 - Spools page 18
 - "A" side spool positioners page 20
 - "B" side options page 22
 - Complete controls. page 23
 - Port valves. page 25
- Intermediate section
 - CS1 mid return manifold section. page 27
- Outlet section
 - Parts ordering codes page 28
 - Dimensional data and hydraulic circuit page 28
- Installation and maintenance page 29
- Accessories page 30

Working conditions

This catalogue shows technical specifications and diagrams measured with mineral oil of 46mm²/s - 46 cSt viscosity at 40°C - 104°F temperature.

Nominal flow rating		400 l/min	105 US gpm
Max. pressure ⁽¹⁾	inlet port P and working ports A and B	315 bar	4600 psi
Max back pressure T	outlet port T	25 bar	360 psi
Internal leakage A(B)⇒T	Δp = 100 bar - 1450 psi	25 cm ³ /min	1.53 in ³ /min
	With port valves Δp = 100 bar - 1450 psi	30 cm ³ /min	1.83 in ³ /min
Fluid		olio a base minerale	
Fluid temperature	with NBR (BUNA-N) seals	from -20°C to 80°C	from -4°F to 176°F
	with FPM (VITON) seals	from -20°C to 100°C	from -4°F to 212°F
Viscosity	operating range	from 15 to 75 mm ² /s	from 15 to 75 cSt
	min.	12 mm ² s	12 cSt
	max.	400 mm ² s	400 cSt
Max. contamination level		-/19/16 - ISO 4406	NAS 1638 - class 10
Ambient temperature for working conditions	with mechanical devices	from -40°C to 60°C	from -40°F to 140°F
	with Hydraulic devices	from -30°C to 60°C	from -22°F to 140°F
Tie rod tightening torque		130 Nm	96 lbft

NOTE - ⁽¹⁾ Intermittent pressure at max. 1 million cycles with specific internal testing.

Standard threads

REFERENCE STANDARD				
		BSP	UN-UNF	Flange connection
THREAD ACCORDING TO		ISO 228/1	ISO 263	ISO 6162
		BS 2779	ANSI B1.1 unified	SAE J518
CAVITY	ISO	1179-1	11926-1	
DIMENSION	SAE		J1926-1	SAE J518 code 61
ACCORDING TO	DIN	3852-2 shape X or Y		ISO 6162-1

PORTS THREADING				
MAIN PORTS	BSP	UN-UNF	flange connection (bolts threading)	
			ISO6162-1 (type 1)	SAE J518 code 61
Inlet P	G 1 1/2	1 7/8-12 (SAE 24)	DN 38 (M12)	1-1/2 (1/2-13 UNC)
Inlet P1	G 1 1/4	1 5/8-12 (SAE 20)	-	-
Port A and B	G 1 1/4	1 5/8-12 (SAE 20)	DN 32 (M10)	1-1/4 (7/16-14 UNC)
Outlet T	G 1 1/2	1 7/8-12 (SAE 24)	DN 38 (M12)	1-1/2 (1/2-13 UNC)
Outlet T1	G 1 1/2	1 7/8-12 (SAE 24)	DN 32 (M10)	1-1/4 (7/16-14 UNC)
Outlet T2	G 1 1/2	1 5/8-12 (SAE 24)	DN 32 (M10)	1-1/4 (7/16-14 UNC)
M	G 1/4	9/16-18 (SAE 6)	G 1/4	9/16-18 (SAE 6)
PILOT PORTS				
Hydraulic	G 3/8	9/16-18 (SAE 8)	G 3/8	9/16-18 (SAE 8)

Dimensional data

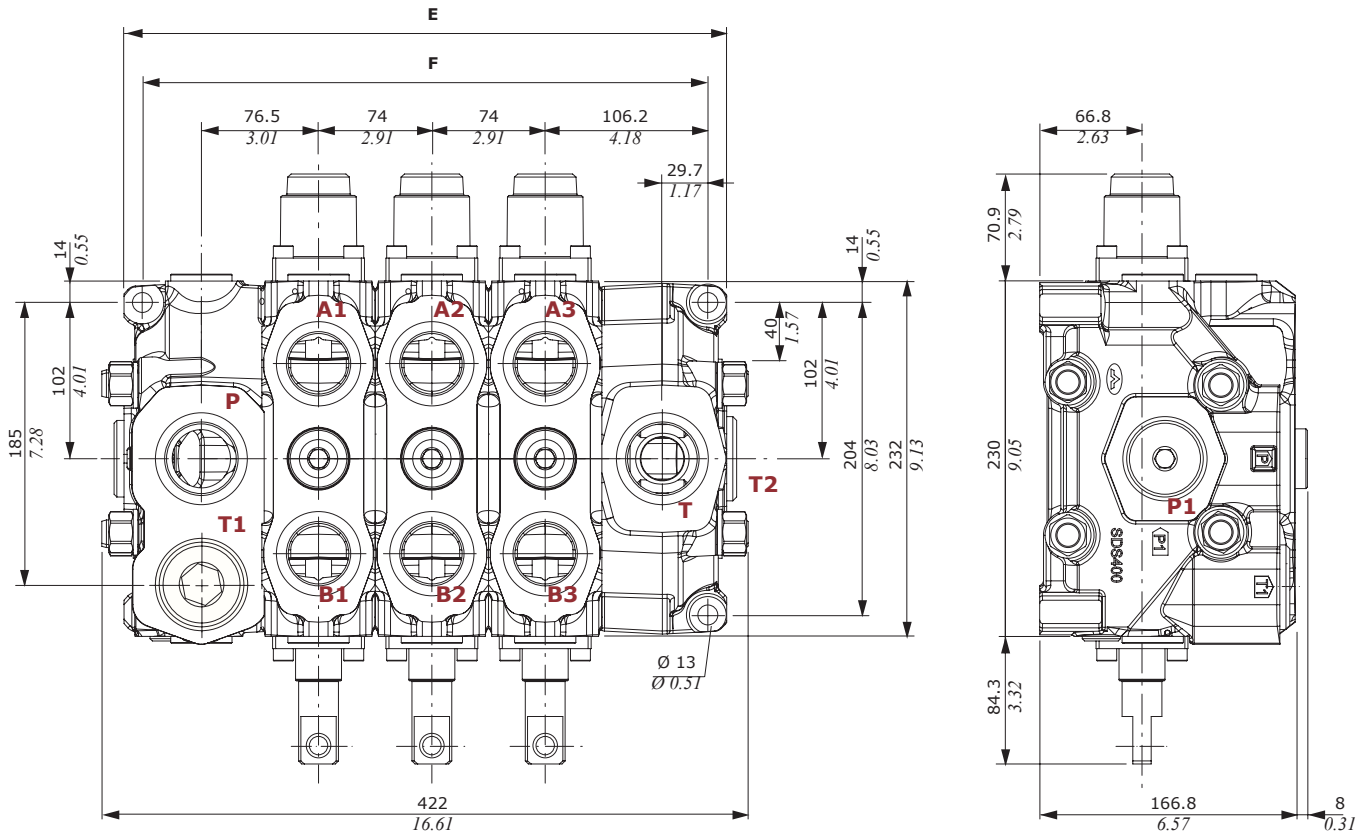

NOTE: Drawings and dimensions are referred to **BSP** thread configuration.

TYPE	E		F		Weight	
	mm	in	mm	in	Kg	lb
SDS400/1	247	9.72	221.2	8.71	44	97
SDS400/2	321	12.64	295.2	11.62	60.5	133.4
SDS400/3	395	15.55	369.2	14.53	77	169.8
SDS400/4	469	18.46	443.2	17.45	93.5	206.1
SDS400/5	543	21.37	517.2	20.36	110	242.5

TYPE	E		F		Weight	
	mm	in	mm	in	Kg	lb
SDS400/6	617	24.29	591.2	23.27	126.5	278.9
SDS400/7	691	27.20	665.2	26.19	143	315.3
SDS400/8	765	30.12	739.2	29.10	159.5	351.6
SDS400/9	839	33.03	813.2	32.01	176	388
SDS400/10	913	35.94	887.2	34.93	192.5	424.4

Performance data

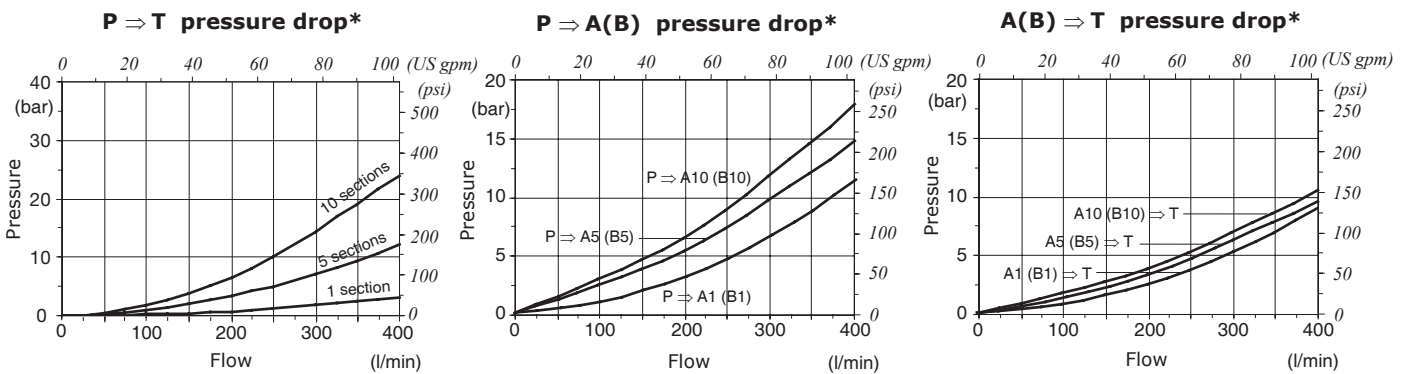

(*): Referred to spool 103

Hydraulic circuit

Parallel circuit

Standard configuration.

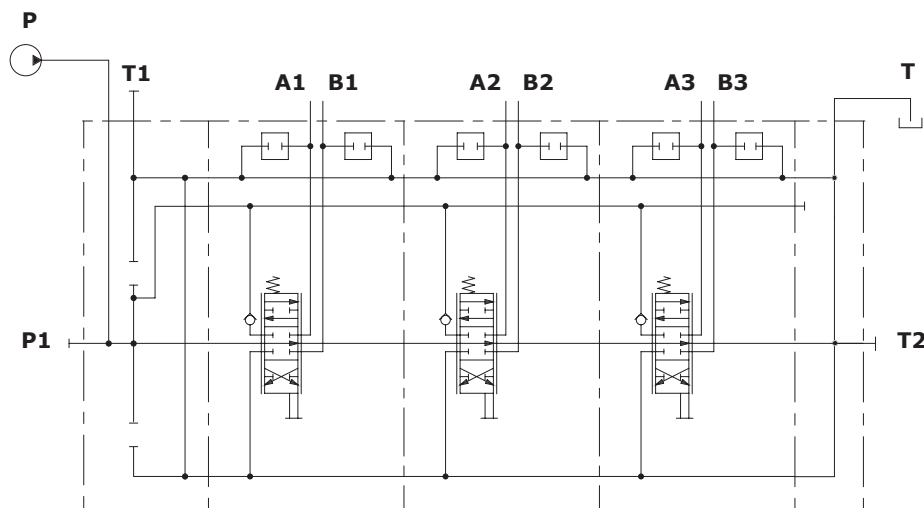

Description example:
SDS400/3/AD(SV)/103-8SLP/103-8SLP/103-8SLP/RD

Series-parallel (tandem) circuit

A special working section kit is needed. Tandem section is fed from the free flow pressure line; it's excluded when an up stream section is operated.

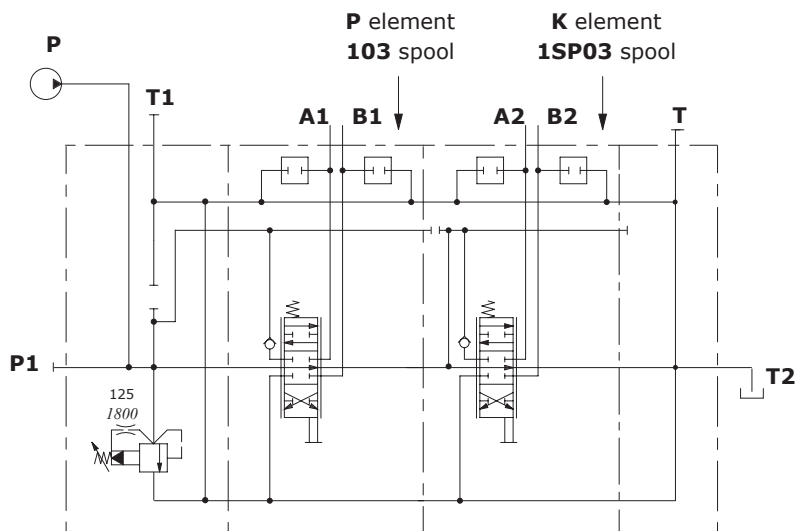

Description example:
SDS400/2/AC(XG-125)/103-8SLP/K-1SP03-8SLP/RC

Series circuit

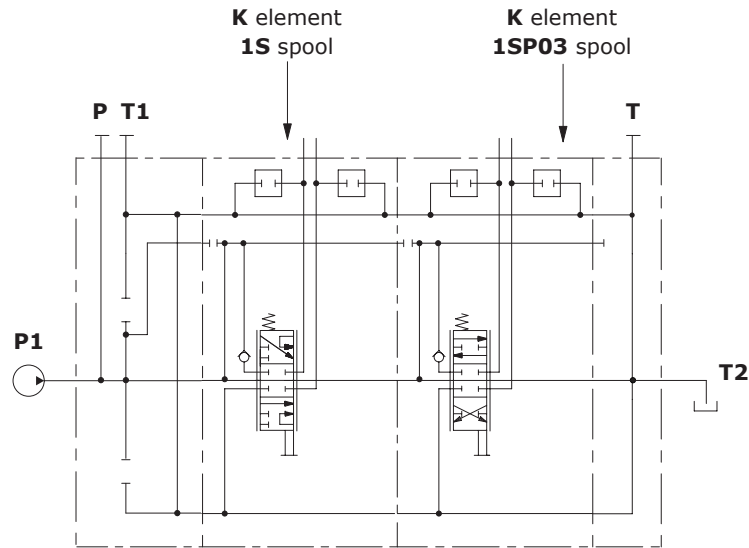

Description example:
SDS400/AC(SV)/K-1S-8SLP/K-1SP03-8SLP/RC

Right inlet directional valve

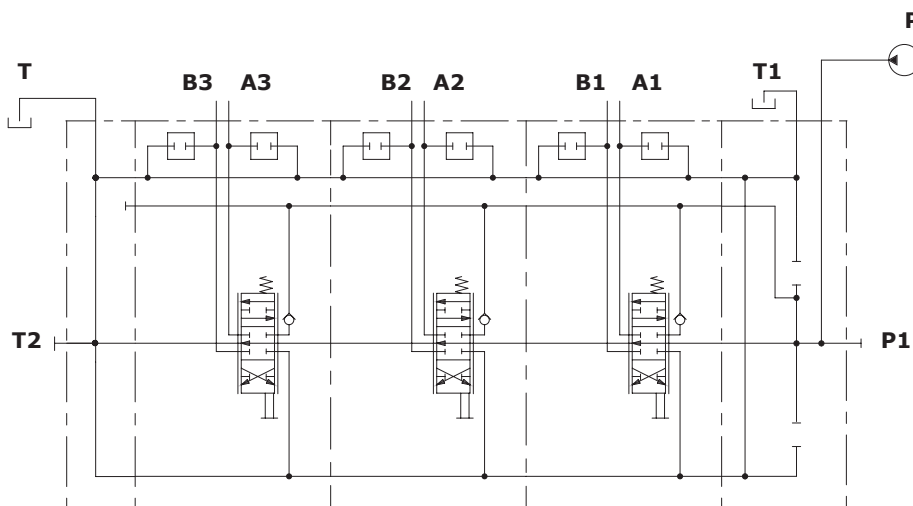

Description example:
SDS400/3/BD(SV)/103-8SLP/103-8SLP/103-8SLP/RD

Complete sections ordering codes

Standard configuration with upper inlet and outlet

SDS400 / 2 / AD(XG3-250) / 103-8SLP / 103-8SLP / RD - ... - <CVN>

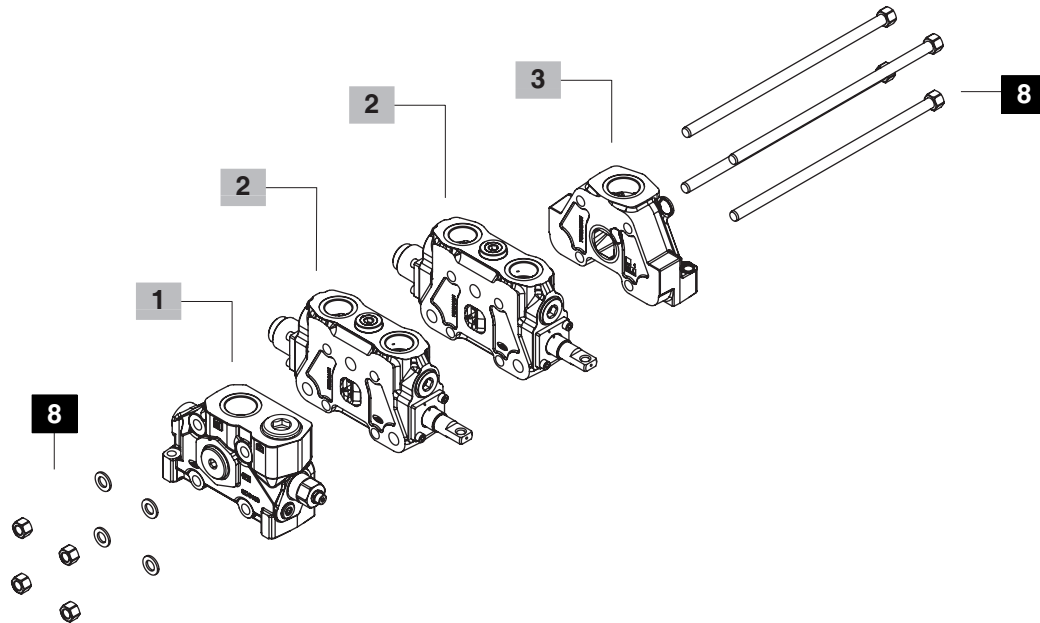
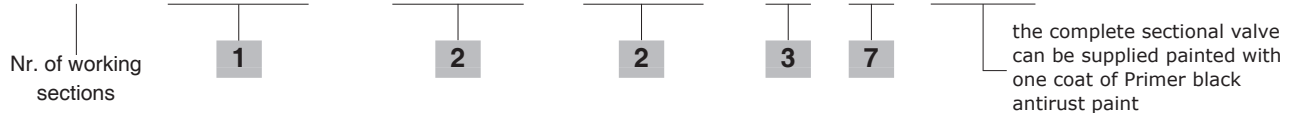

1 Inlet section * page 10

TYPE: **SDS400/AC(XG3-250)** CODE: 61G201000
 DESCRIPTION: With side inlet port and relief valve, P and T1 upper ports plugged

TYPE: **SDS400/AD(XG3-250)** CODE: 61G201001
 DESCRIPTION: With upper inlet port and relief valve, P1 side port and T1 upper port plugged

TYPE: **SDS400/ADA-FS3M (XG3-250)** CODE: 61G201900
 DESCRIPTION: Upper port with ISO6162-1 type 1, without side inlet, with relief valve

2 Working section * page 14

TYPE: **SDS400/103-8SLP** CODE: 61G101000
 DESCRIPTION: Parallel circuit, double acting without lever, with spring return, arranged for port valves

TYPE: **SDS400/K-1SP03-8SLP** CODE: 61G101003
 DESCRIPTION: Series-parallel circuit, double acting without lever, with spring return, arranged for port valves

TYPE: **SDS400/K-1S03-8SLP** CODE: 61G101004
 DESCRIPTION: Series circuit, double acting without lever, with spring return, arranged for port valves

TYPE: **SDS400/P5Y-5RSA03-13SLPF** CODE: 61G101001
 DESCRIPTION: Floating circuit with spool in, double acting without lever with spring return, arranged for port valves

TYPE: **SDS400/P5W-5RSB03-13CSLP** CODE: 61G101002
 DESCRIPTION: Floating circuit with spool out, double acting without lever with spring return, arranged for port valves

3 Outlet section * page 28

TYPE: **SDS400/RC** CODE: 61G301000
 DESCRIPTION: Side port open, upper port plugged

TYPE: **SDS400/RD** CODE: 61G301001
 DESCRIPTION: Upper port open, side port plugged

TYPE: **SDS400/RE** CODE: 61G301002
 DESCRIPTION: Upper port open and carry-over

TYPE: **SDS400/RK** CODE: 61G301003
 DESCRIPTION: For closed center circuit

TYPE: **SDS400/RDA-FS3M** CODE: 61G301900
 DESCRIPTION: With ISO6162-1 type 1 flange connection, upper port, without side port

TYPE: **SDS400/RE-FS3M** CODE: 61G301901
 DESCRIPTION: With ISO6162-1 type 1 flange connection, upper port, with carry-over

7 Ports threading page 4

Specify only if different from standard **BSP** thread (see page 4), for flange connection according to ISO 6162-1 type 1, indicate: **FS3M**.

NOTE (*) – Codes are referred to **BSP** thread.

Complete sections ordering codes

Configuration with 2 upper inlets and mid return manifold

SDS400 / 2 / AD(XG3-250) / P5Y-5RSA03-13SLPF / CS1/ P5W-5RSA03-13SLPF / BD(XG3-250) - ...

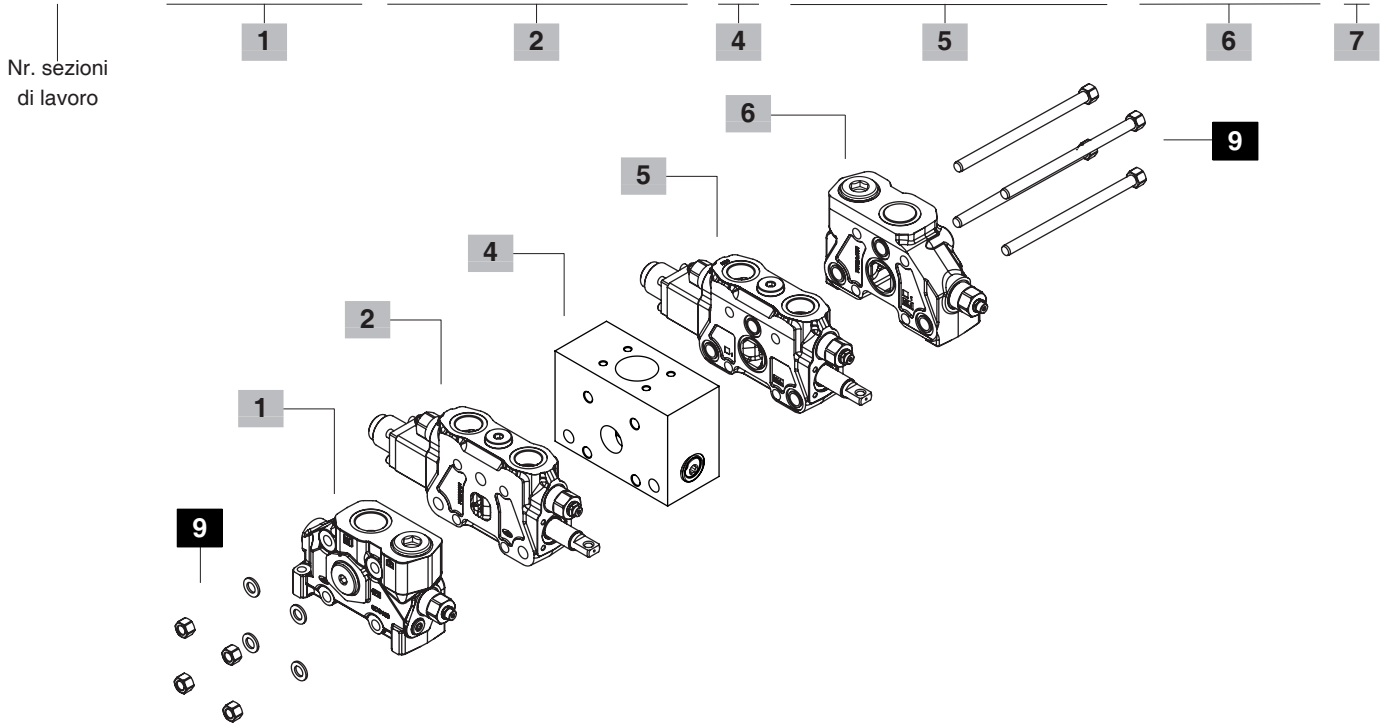

4 Mid return manifold * page 27

TYPE	CODE	DESCRIPTION
CS1-FS3M	61G401900	Mid return manifold with ISO6162-1 type 1 flange connection

5 Working section for right inlet *

TYPE: SDS400/ED-103-8SLP	CODE: 61G101005	DESCRIPTION: Parallel circuit, double acting without lever, with spring return, arranged for port valves
TYPE: SDS400/K-ED-1SP03-8SLP	CODE: 61G101006	DESCRIPTION: Series-parallel circuit, double acting without lever, with spring return, arranged for port valves
TYPE: SDS400/K-ED-1S03-8SLP	CODE: 61G101007	DESCRIPTION: Series circuit, double acting without lever, with spring return, arranged for port valves
TYPE: SDS400/P5Y-ED-5RSB03-13CSLP	CODE: 61G101008	DESCRIPTION: Floating circuit with spool out, double acting without lever, with spring return, arranged for port valves
TYPE: SDS400/P5W-ED-5RSA03-13SLPF	CODE: 61G101009	DESCRIPTION: Floating circuit with spool in, double acting without lever, with spring return, arranged for port valves

6 Right inlet section *

TYPE: SDS400/BC(XG3-250)	CODE: 61G201002	DESCRIPTION: With side inlet port and relief valve, P and T1 upper ports plugged
TYPE: SDS400/BD(XG3-250)	CODE: 61G201003	DESCRIPTION: With upper inlet port and relief valve, P1 side port and T1 upper port plugged
TYPE: SDS400/BDA-FS3M (XG3-250)	CODE: 61G201901	DESCRIPTION: Upper port with ISO6162-1 type 1 flange connection, without side inlet, with relief valve

8 Assemb. kit without intermediate section

CODE	DESCRIPTION
5TIR116274	Tie rod kit for 1 working section directional valve
5TIR116348	Tie rod kit for 2 working sections directional valve
5TIR116422	Tie rod kit for 3 working sections directional valve
5TIR116496	Tie rod kit for 4 working sections directional valve
5TIR116570	Tie rod kit for 5 working sections directional valve
5TIR116644	Tie rod kit for 6 working sections directional valve
5TIR116718	Tie rod kit for 7 working sections directional valve
5TIR116792	Tie rod kit for 8 working sections directional valve
5TIR116866	Tie rod kit for 9 working sections directional valve
5TIR116940	Tie rod kit for 10 working sections directional valve

9 Assemb. kit with intermediate section

CODE	DESCRIPTION
5TIR116458	Tie rod kit for 2 working sections directional valve
5TIR116532	Tie rod kit for 3 working sections directional valve
5TIR116606	Tie rod kit for 4 working sections directional valve
5TIR116680	Tie rod kit for 5 working sections directional valve
5TIR116754	Tie rod kit for 6 working sections directional valve
5TIR116828	Tie rod kit for 7 working sections directional valve
5TIR116902	Tie rod kit for 8 working sections directional valve
5TIR116976	Tie rod kit for 9 working sections directional valve
5TIR11699A	Tie rod kit for 10 working sections directional valve

NOTE (*) – Codes are referred to **BSP** thread

Parts ordering codes

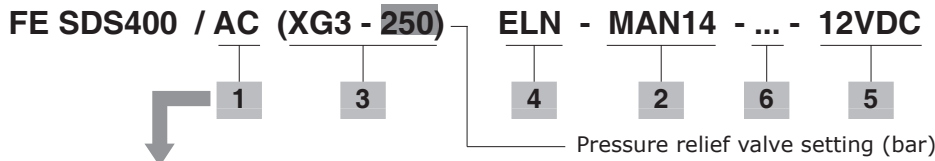

Available configurations

- AC:** lateral inlet port
- AD:** top inlet port, lateral port plugged
- ADA FS3:** Only top inlet, SAE flange

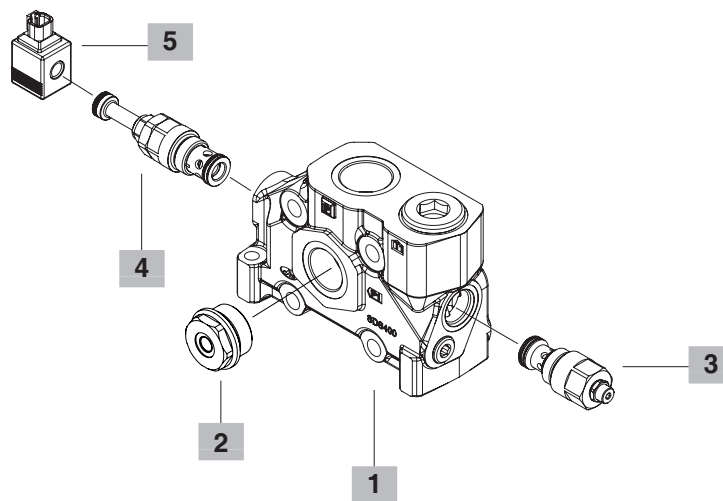

1	Inlet section body *	page 11
TYPE:	AC-AD-NOTAP(T1)	CODE: 5FIA140301
DESCRIPTION:	Standard body, lateral inlet port or upper inlet port, T1 upper port open	
TYPE:	AC-AD	CODE: 5FIA140300
DESCRIPTION:	Standard body, lateral inlet port or upper inlet port, T1 upper port plugged	
TYPE:	ADA-FS3M	CODE: 5FIA140290
DESCRIPTION:	Body ISO 6162-1 type 1 flange connection, T1 upper port with blind flange	

2	Parts *	
TYPE	CODE	DESCRIPTION
For AD inlet section		
-	XTAP750240	G 1-1/4 plug (omitted in description)
MAN14	XGIU641241	G 1 1/4-G 1/4 pressure gauge arrangement
For AC inlet section		
-	XTAP717301	G 1-1/2 plug (omitted in description)

3	Main relief valve	page 12
Standard setting is referred to 10 l/min - 2.6 USgpm flow		
TYPE	CODE	DESCRIPTION
XG2	OMP16002013	Setting range 50-220 bar (725-3200 psi) Standard setting 150 bar (2200 psi)
XG3	OMP16002014	Setting range 150-350 bar (2200-5100 psi) Standard setting 250 bar (3600 psi)

4	Inlet relief valve options	page 13
TYPE	CODE	DESCRIPTION
SV	XTAP540480	Relief valve blanking plug
F	X395320000	Inlet anti-cavitation valve
L	X277510000	Hydraulic operated unloader valve
Solenoid operated unloader valve		
ELN	0EFW2772000	Without emergency
ELP	0EFW2772001	Push-button emergency
ELV	0EFW2772002	Screw type emergency
ELT	0EFW2772003	Push and twist type with detent emergency

5	Coils	page 29
TYPE	CODE	DESCRIPTION
12VDC	4SLE001200	Coil type BER , ISO4400 integrated type 12 VDC
For complete available coils list see page 27		

6	Ports threading	page 4
Specify only if different from standard BSP thread (see page 4), for flange connection according to ISO 6162-1 type 1, indicate: FS3M .		

NOTE (*) - Codes are referred to **BSP** thread.

Dimensional data and hydraulic circuit

AC-AD type

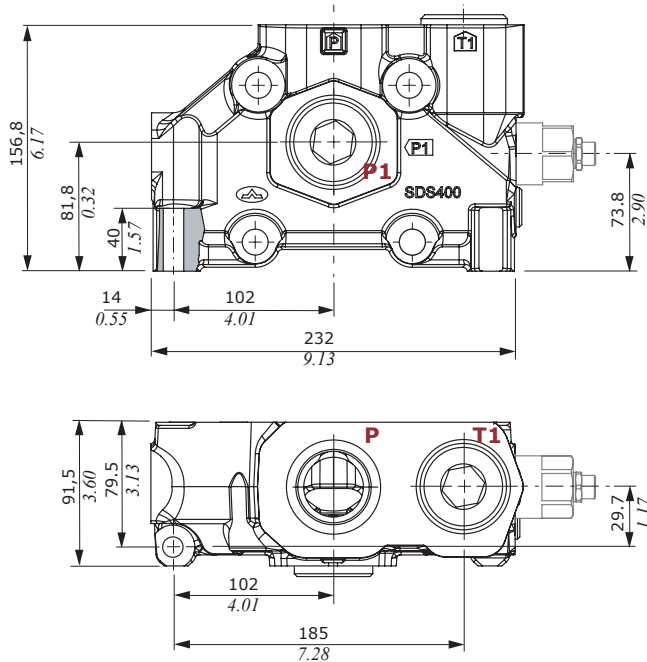

**AD FS3M type
(ISO flange connection)**

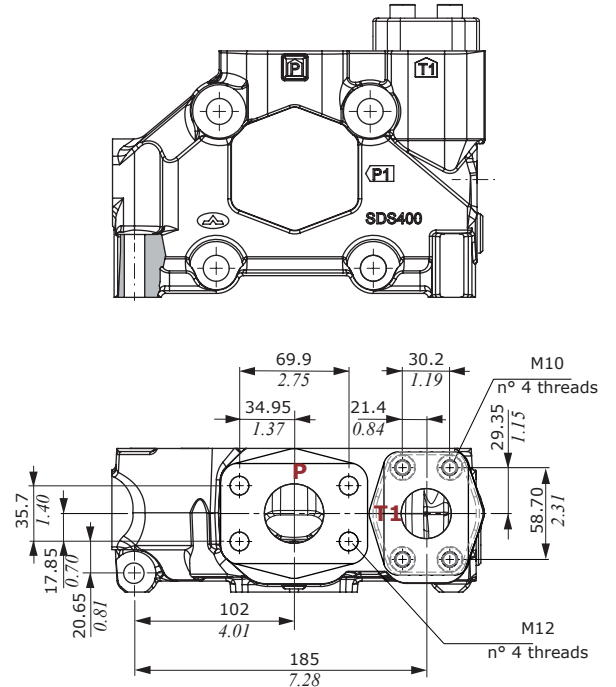

For left inlet directional valve, side port

For left inlet directional valve, upper port

For right inlet directional valve, side port

For right inlet directional valve, upper port

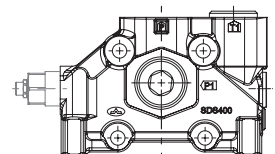
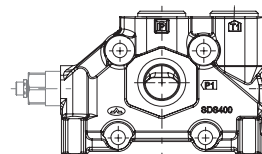
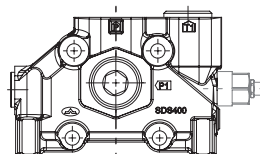
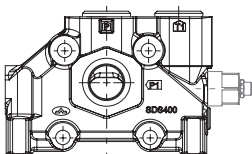
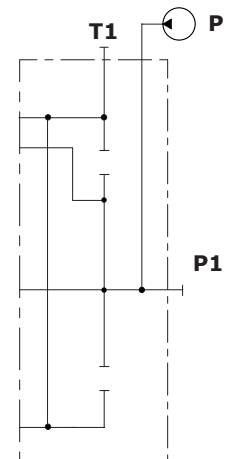
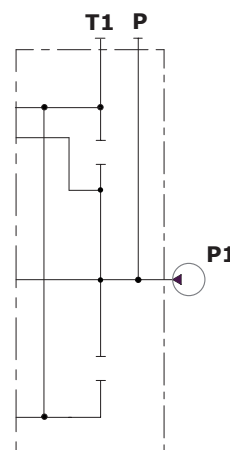
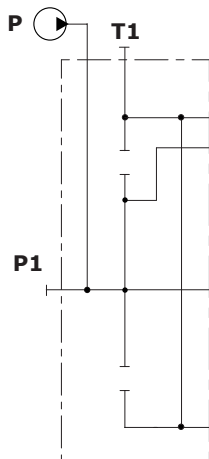
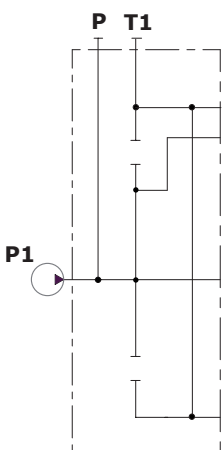

Description example:
AC(SV)

Description example:
AD(SV)

Description example:
BC(SV)

Description example:
BD(SV)

Main relief valve

Pilot operated main relief valve

Description example: X G 3 - 250

Valve setting (bar)
Spring type

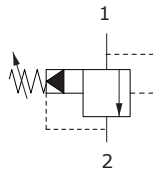
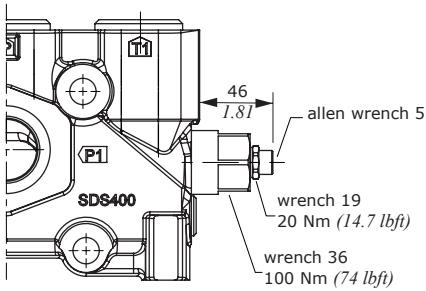

XG2 valve setting range

From 50 to 220 bar (725-3200 psi)

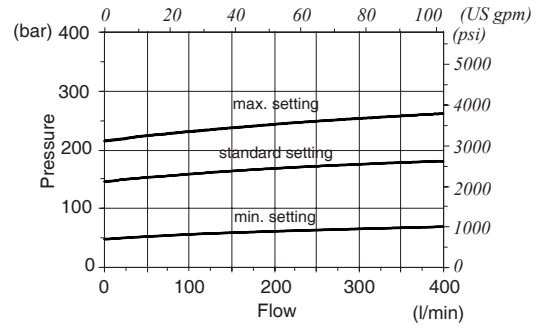

XG3 valve setting range

From 150 to 350 bar (2200-5100 psi)

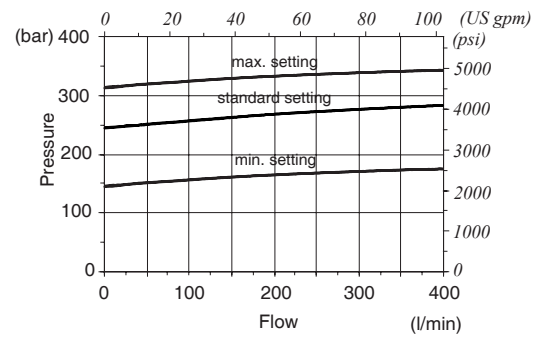

Inlet relief valve options

Anticavitation valve

Description example: AC (XG3 - 150) F

Anticavitation valve

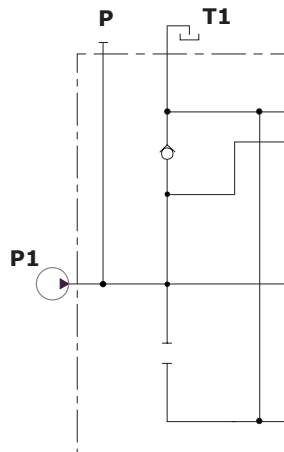
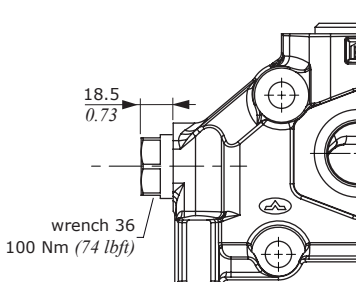

Pressure drop T1 → P

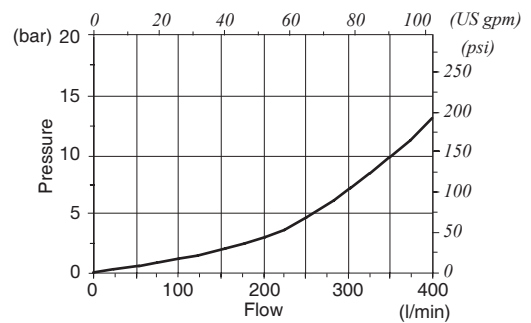

Inlet relief valve options

Unloader valves

Description example: AC (XG3 - 150) L

Hydraulic operated valve: L

Solenoid operated valve: EL

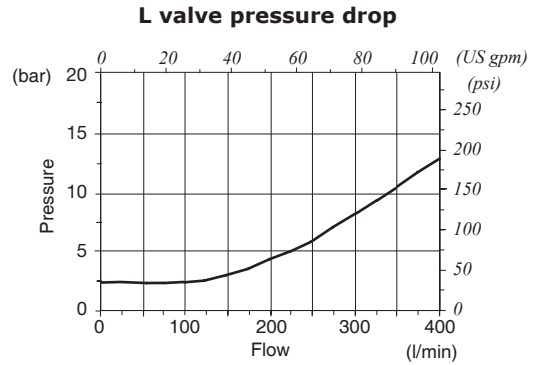
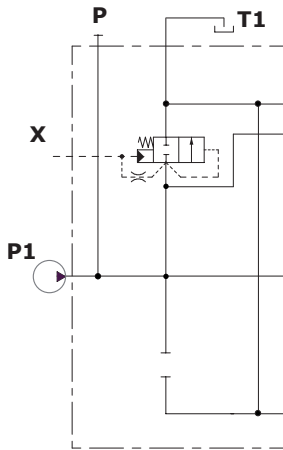
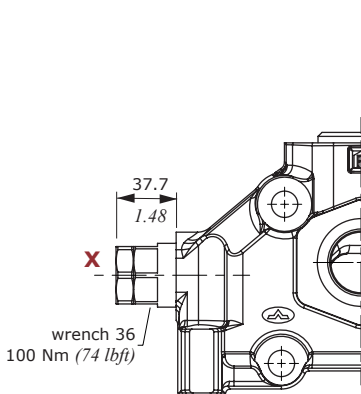

Features

Max. flow : 400 l/min (105 US gpm)

Internal leakage : from 2 to 18 cm³/min @ 100 bar
(from 0.12 to 1.1 in³/min @ 1450 psi)

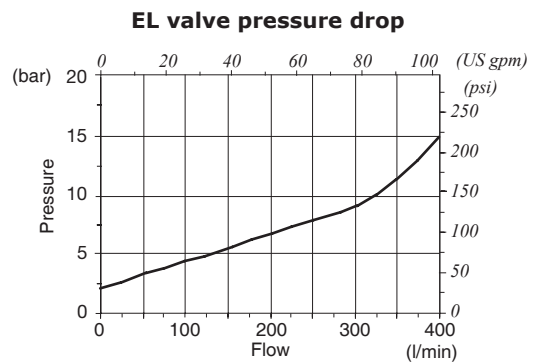
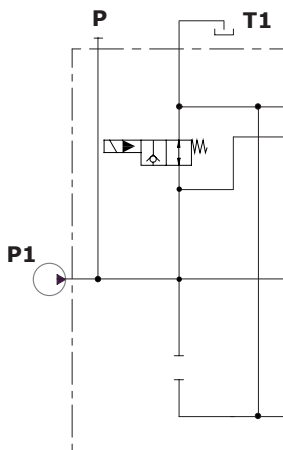
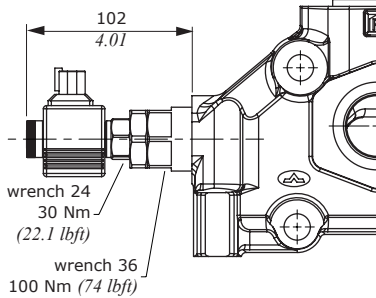

Features

Max. flow : 400 l/min (105 US gpm)

Internal leakage : from 2 to 18 cm³/min @ 100 bar
(from 0.12 to 1.1 in³/min @ 1450 psi)

ELN: without emergency

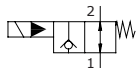

ELP: push button type

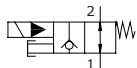

ELV: screw type

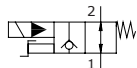

ELT: "push & twist" type

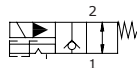

Parts ordering codes (mechanical control)

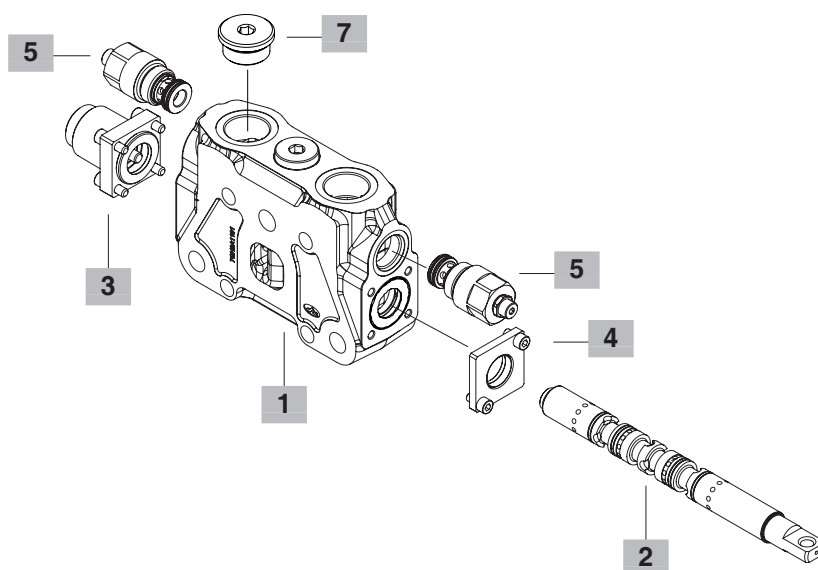
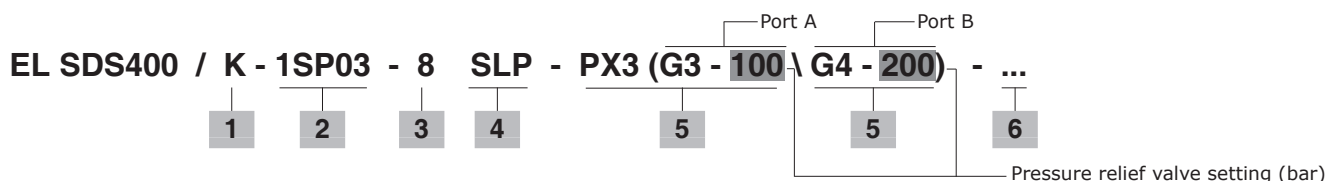

1 Working section kit * page 16

TYPE	CODE	DESCRIPTION
P	5EL1403001	Parallel circuit; standard spool, arranged for port valves ("type" omitted in description)
K	5EL1403700	For series and series-parallel circuit; arranged for port valves, need spool type 1S for series circuit and spool type 1SP for series-parallel circuit
P-FS3M	5EL1402900	As type P with ISO 6162-1 type 1 flange connection
K-FS3M	5EL1402903	As type K with ISO 6162-1 type 1 flange connection

For floating circuit

Needs dedicated positioners (**13-14**) and spools (**5RSA-5RSB**); for left and right inlet combinations see page 20

P5Y	5EL1403200	Arranged for port valves
P5W	5EL1403201	Arranged for port valves
P5Y-FS3M	5EL1402901	As type P5Y with ISO 6162-1 type 1 flange connection
P5W-FS3M	5EL1402902	As type P5W with ISO 6162-1 type 1 flange connection

2 Spools ⁽¹⁾ page 18

TYPE	CODE	DESCRIPTION
101	3CU2810000	Double acting, 3 positions, with A and B closed in neutral position Q=200 l/min (53 USgpm)
102	3CU2810001	As previous Q=300 l/min (79 USgpm)
103	3CU2810002	As previous Q=400 l/min (106 USgpm)
201	3CU2825000	Double acting, 3 positions, with A and B open to tank in neutral position Q=200 l/min (53 USgpm)
202	3CU2825001	As previous Q=300 l/min (79 USgpm)
203	3CU2825002	As previous Q=400 l/min (106 USgpm)
2H03	3CU2824002	Double acting, 3 positions, with A and B partially connected to tank in neutral position Q=200 l/min (53 USgpm)
303	3CU2831000	Single acting on A, 3 positions, B plugged Q=400 l/min (106 USgpm)
1S	3CU2810100	Series spool, double acting, 3 positions, with A and B closed in neutral position
2S	3CU2825100	Series spool, double acting, 3 positions, with A and B open to tank in neutral position
1SP01	3CU2813000	Series-parallel spool, double acting, 3 positions, with A and B closed in neutral position Q=200 l/min (53 USgpm)
1SP02	3CU2813001	As previous Q=300 l/min (79 USgpm)
1SP03	3CU2813002	As previous Q=400 l/min (106 USgpm)

For floating circuit

Needs dedicated sections (**P5Y-P5W**) positioners (**13-14**); for left and right inlet combinations see page 20

5RSA01	3CU2844000	Double acting spool with A and B closed in neutral position, 4 positions, floating 4 th position, with spool in, restricted on port A return flow Q=200 l/min (53 USgpm)
5RSA02	3CU2844001	As previous Q=300 l/min (79 USgpm)
5RSA03	3CU2844002	As previous Q=400 l/min (106 USgpm)
5RSB01	3CU2844003	Double acting spool with A and B closed in neutral position, 4 positions, floating 4 th position, with spool out, restricted on port B return flow Q=200 l/min (53 USgpm)
5RSB02	3CU2844004	As previous Q=300 l/min (79 USgpm)
5RSB03	3CU2844005	As previous Q=400 l/min (106 USgpm)

3 "A" side spool positioner page 20

TYPE	CODE	DESCRIPTION
8	5V0810B000	3 positions with spring return in neutral position
11	5V1110B000	3 positions, detent in all positions
13	5V1310B000	4 positions with spring return in neutral position, detent in 4 th position with spool-in; need spool 5RSA
13C	5V1310B001	4 positions with spring return in neutral position, detent in 4 th position with spool-out; need spool 5RSB
14	5V1410B000	4 positions, detent in all position. 4 th position with spool-in; need spool 5RSA
14C	5V1410B001	4 positions, detent in all position. 4 th position with spool-out; need spool 5RSB

4 "B" side options page 22

TYPE	CODE	DESCRIPTION
LB1-3	5LEV30B000	Open steel lever for positioner type 8-11-13C-14C
LBF1-3	5LEV30B001	Open steel lever for positioner type 13-14
SLP	5COP140000	Without lever, with dust-proof plate positioner type 8-11-13C-14C
SLPF	5COP140001	Without lever, with dust-proof plate positioner type 13-14

5 Port valves page 25

Valves standard setting is referred to 10 l/min - 2.64 USgpm flow

TYPE	CODE	DESCRIPTION
UT	XTAP540110	Blanking plug for ports A and B
C	X33132A000	Anticavitation valve
UX(G-160)	X331421160	Pilot anti-shock and anticavitation valve Setting range 50-350 bar (725-5100 psi) Standard setting 160 bar (2300 psi)

Pilot operated antishock valves

PX(G2-150)	X33121B150	Setting range 50-220 bar (725-3200 psi) Standard setting 150 bar (2200 psi)
PX(G3-250)	X33121B250	Setting range 150-350 bar (2200-5100 psi) Standard setting 250 bar (3600 psi)

Antishock valves

P(YG3-175)	X331129175	Setting range 100-200 bar (1450-2900 psi) Standard setting 175 bar (2500 psi)
P(YG4-250)	X331129250	Setting range 150-315 bar (2200-4600 psi) Standard setting 250 bar (3600 psi)

6 Ports threading page 4

Specify only if different from standard **BSP** thread (see page 4), for flange connection according to ISO 6162-1 type 1, indicate: **FS3M**.

7 Plug for single acting spool *

CODE	DESCRIPTION
XTAP750240	Plug G 1 1/4
4FL1080210	Blind flange DN32

NOTE (*) – All codes are referred to **BSP** thread.

(1) – Spools partially connect to tank type **1RSA** and **1RSB** on request.

Dedicated spools for applications available on request.

Parts ordering codes (proportional hydraulic control)

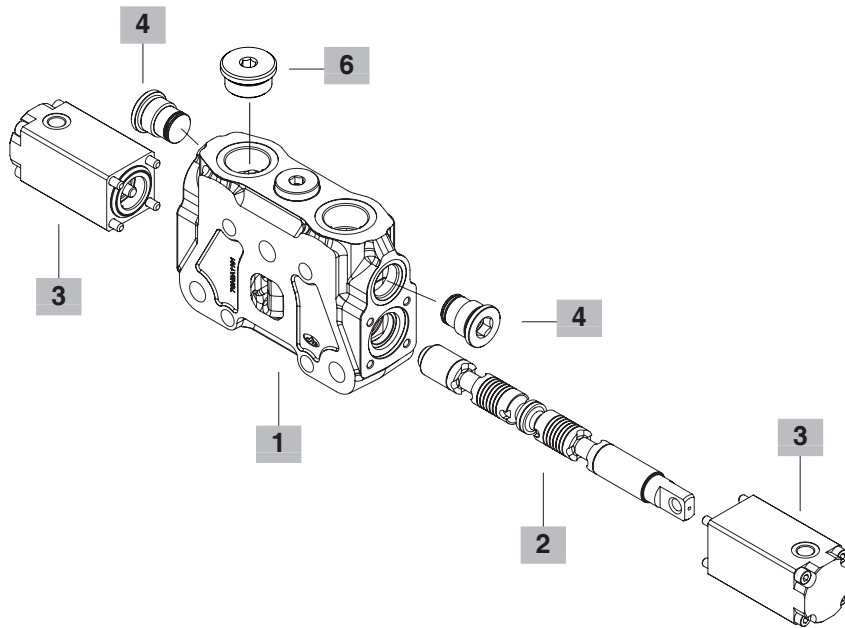
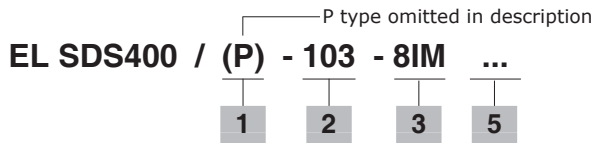

1 Working section kit * page 17

TYPE	CODE	DESCRIPTION
P(IM)	5EL1403001A	Parallel circuit; standard spool, arranged for port valves ("type" omitted in description)
K(IM)	5EL1403700A	For series and series-parallel circuit; arranged for port valves, need spool type 1S for series circuit and spool type 1SP for series-parallel circuit
P-FS3M(IM)	5EL1402900A	As type P with ISO 6162-1 type 1 flange connection
K-FS3M(IM)	5EL1402903A	As type K with ISO 6162-1 type 1 flange connection

For floating circuit

Needs dedicated positioners (**13IM**) and spools (**5RSA-5RSB**); for left and right inlet combinations see page 20

P5Y(IM)	5EL1403200	Arranged for port valves
P5Y-FS3M(IM)	5EL1402901	As type P5Y with ISO 6162-1 type 1 flange connection

2 Spools page 18

See page 15

3 Complete controls * page 23

TYPE	CODE	DESCRIPTION
8IM	5IDR20B300	Double side proportional hydraulic control with spring return to neutral
13IM	5IDR20B310	Double side proportional hydraulic control with spring return to neutral, for floating circuit with spool-in. Need spool 5RSA

4 Port valves page 25

See page 15

5 Ports threading page 4

Specify only if different from standard **BSP** thread (see page 4), for flange connection according to ISO 6162-1 type 1, indicate: **FS3M**.

6 Plug for single acting spool *

CODE	DESCRIPTION
XTAP750240	Plug G 1 1/4
4FL1080210	Blind flange DN32

NOTE (*) – Codes are referred to **BSP** thread.

Dimensional data and hydraulic circuit

P/K type

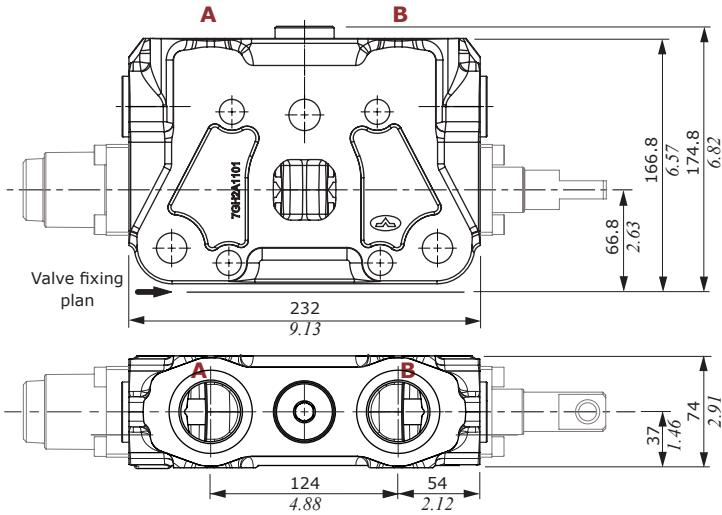

P type

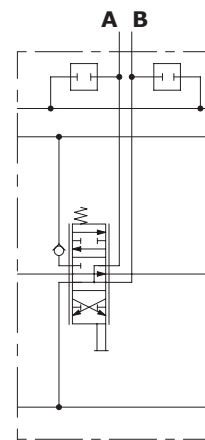

K type

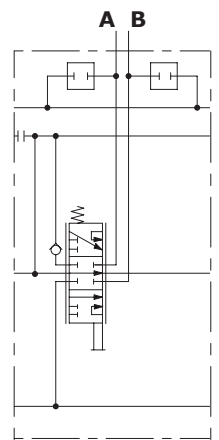

P/K-FS3M type
(ISO flange connection)

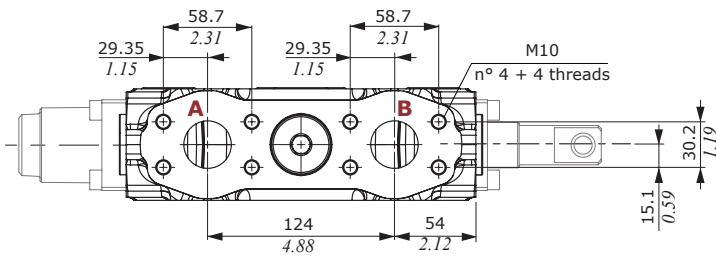

Spools

Type 1 (101/102/103) spool

Double acting, 3 positions, with A and B closed in neutral position

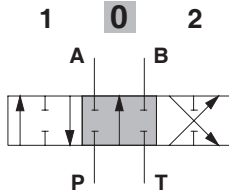

Spool stroke

position 1: - 12 mm (-0,47 in)
position 2: + 12 mm (+0,47 in)

Type 1 spool metering

$Q_{in} = 400 \text{ l/min} / (105 \text{ US gpm}) - P_{(on ports)} = 100 \text{ bar} / (1450 \text{ psi})$

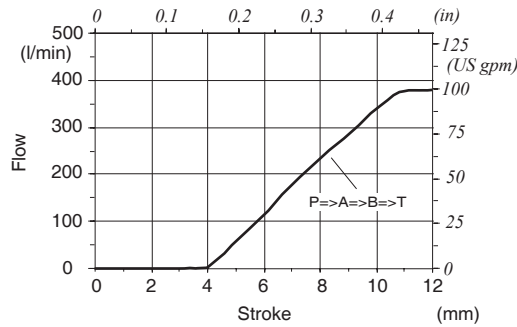

Type 2 (201/202/203) spool

Double acting, 3 positions, with A and B open to tank in neutral position

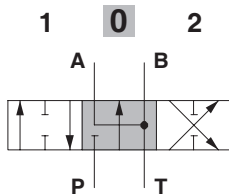

Spool stroke

position 1: - 12 mm (-0,47 in)
position 2: + 12 mm (+0,47 in)

Type 2H (2H03) spool

Double acting, 3 positions, with A and B partially connected to tank in neutral position

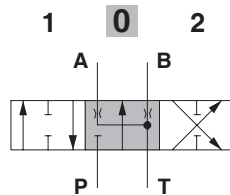

Spool stroke

position 1: - 12 mm (-0,47 in)
position 2: + 12 mm (+0,47 in)

Type 3 (303) spool

Single acting on A, 3 positions, B plugged

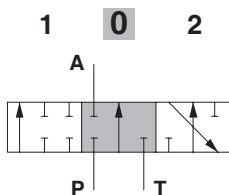

Spool stroke

position 1: - 12 mm (-0,47 in)
position 2: + 12 mm (+0,47 in)

Type 5RSA (01/02/03) spool

Double acting spool with A and B closed in neutral position, 4 positions, with spool in, floating 4th position, restricted on port A return flow

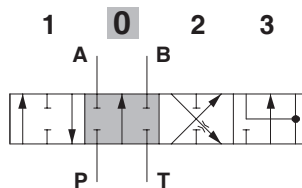

Spool stroke

position 1: - 12 mm (-0,47 in)
position 2: + 12 mm (+0,47 in)
position 3: + 20 mm (+0,79 in)

Type 5RSB (01/02/03) spool

Double acting spool with A and B closed in neutral position, 4 positions, with spool out, floating 4th position, restricted on port B return flow

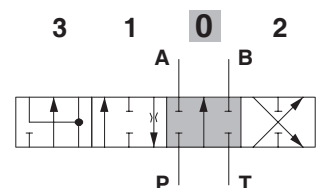

Spool stroke

position 1: - 12 mm (-0,47 in)
position 2: + 12 mm (+0,47 in)
position 3: - 20 mm (+0,79 in)

Type 1S spool

Series spool, double acting, 3 positions, with A and B closed in neutral position

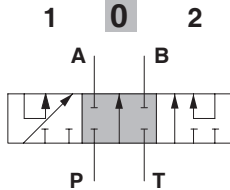

Spool stroke

position 1: - 12 mm (-0,47 in)
position 2: + 12 mm (+0,47 in)

Type 1S spool metering

$Q_{in} = 400 \text{ l/min} / (105 \text{ US gpm}) - P_{(on ports)} = 100 \text{ bar} / (1450 \text{ psi})$

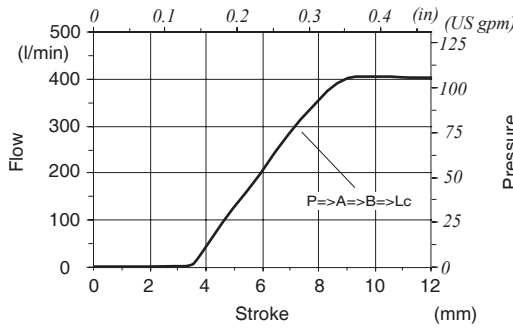

Type 1S spool pressure drop

(3 sections, series on section 2)

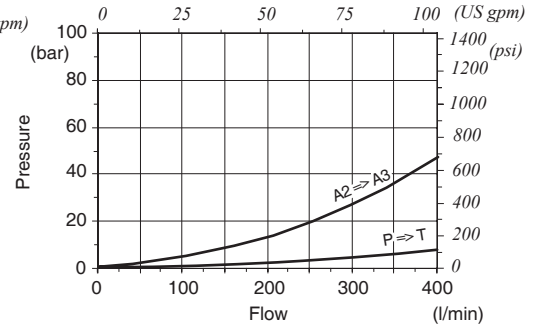

Type 1SP (1SP01/1SP02/1SP03) spool

Series-parallel spool, double acting, 3 positions, with A and B closed in neutral position

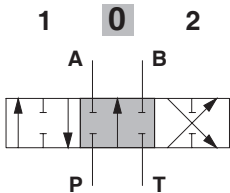

Spool stroke

position 1: - 12 mm (-0,47 in)
position 2: + 12 mm (+0,47 in)

Type 1SP spool metering

$Q_{in} = 400 \text{ l/min} / (105 \text{ US gpm}) - P_{(on ports)} = 100 \text{ bar} / (1450 \text{ psi})$

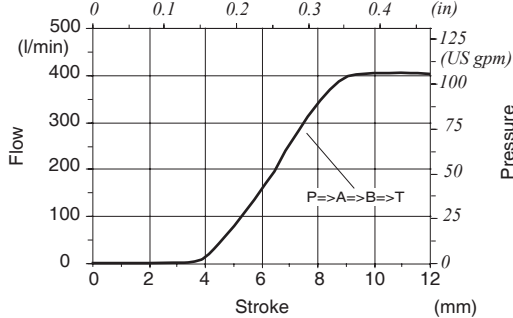

Type 1SP spool pressure drop

(3 sections, series-parallel on section 2)

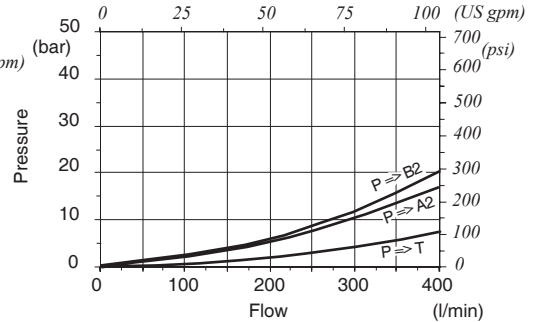

Type 2S spool

Series spool, double acting, 3 positions, with A and B open to tank in neutral position

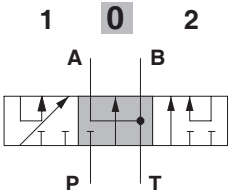

Spool stroke

position 1: - 12 mm (-0,47 in)
position 2: + 12 mm (+0,47 in)

Type 2S spool metering

$Q_{in} = 400 \text{ l/min} / (105 \text{ US gpm}) - P_{(on ports)} = 100 \text{ bar} / (1450 \text{ psi})$

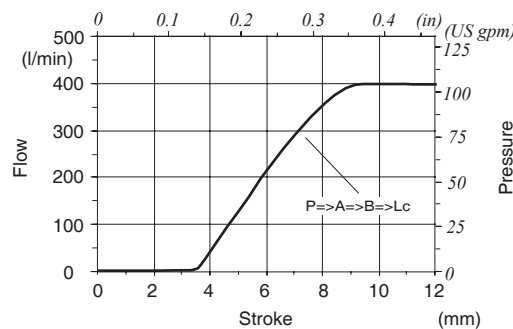

Type 2S spool pressure drop

(2 sections, series on section 1)

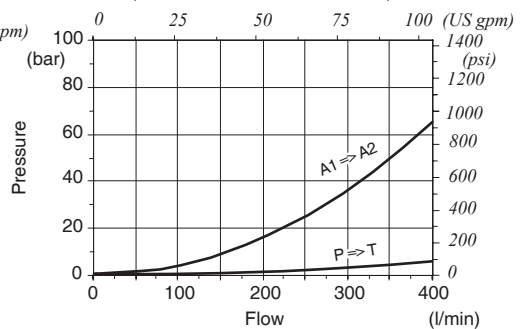

"A" side spool positioners

8 type: with spring return

It's supplied with standard spring type C (see force-stroke diagram). Available with spring type B (**SMB** code: 5V0810B004) and type D (**SMD** code: 5V0810B002).

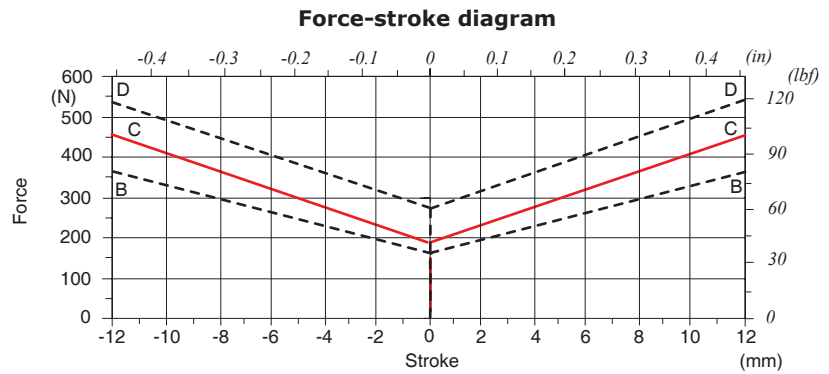
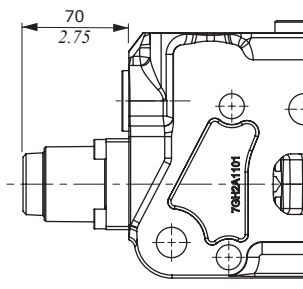
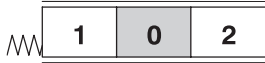

Spring type **B**: stroke 0 = 165 N (37.09 lbf), stroke 12 = 374 N (84.07 lbf)

Spring type **C**: stroke 0 = 190 N (42.71 lbf), stroke 12 = 455 N (102.28 lbf)

Spring type **D**: stroke 0 = 280 N (62.94 lbf), stroke 12 = 544 N (122.29 lbf)

11 type: with detent

Detent in all positions.

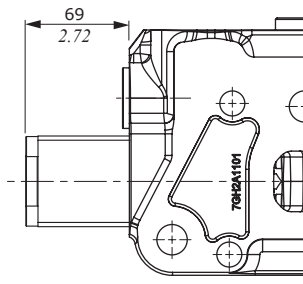

"A" side spool positioners

For floating circuit

13 type

4 positions, spring return in neutral position, detent in 4th position with spool in. Needs spool type **5RSA**.

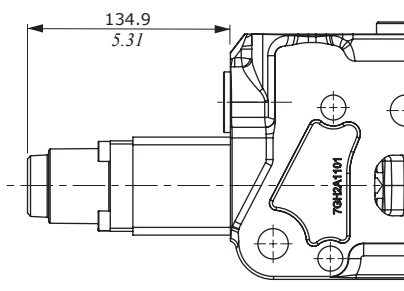
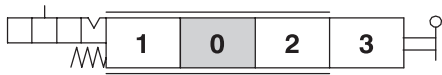

Working section
P5Y cod. 5EL1403200 (left inlet)
P5W cod. 5EL1403201 (right inlet)

13C type

4 positions, spring return in neutral position, detent in 4th position with spool out. Needs spool type **5RSB**.

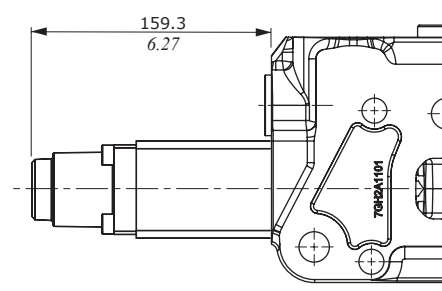
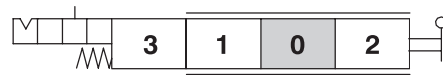

Working section
P5W cod. 5EL1403201 (left inlet)
P5Y cod. 5EL1403200 (right inlet)

14 type

Detent in 4 positions, 4th position with spool-in. Needs spool type **5RSA**.

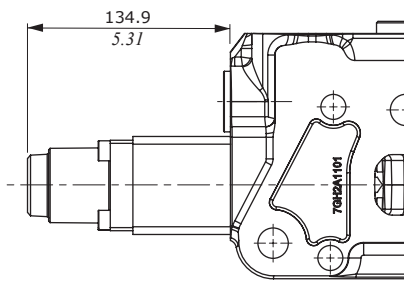

Working section
P5Y cod. 5EL1403200 (left inlet)
P5W cod. 5EL1403201 (right inlet)

14C type

Detent in 4 positions, 4th position with spool-out. Needs spool type **5RSB**.

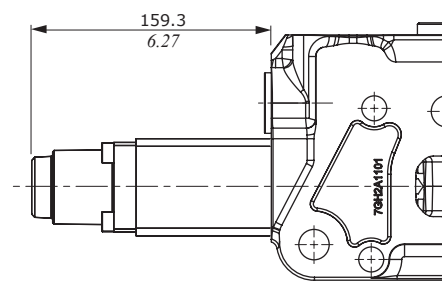
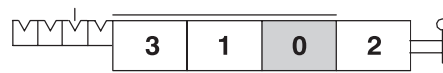

Working section
P5W cod. 5EL1403201 (left inlet)
P5Y cod. 5EL1403200 (right inlet)

"B" side options

LB and LBF types: steel lever control

Type **LB** for positioner type **8-11-13C-14C**. Type **LBF** with seals for positioner type **13** and **14**. Dimensions are the same.

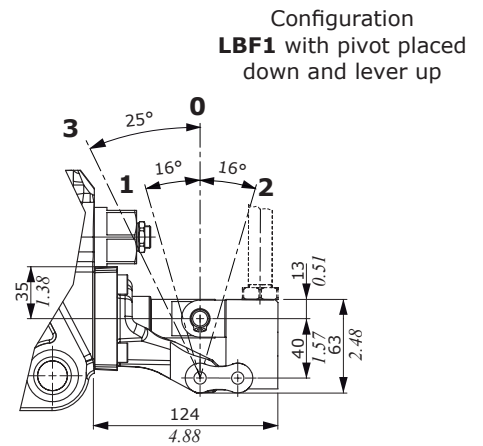
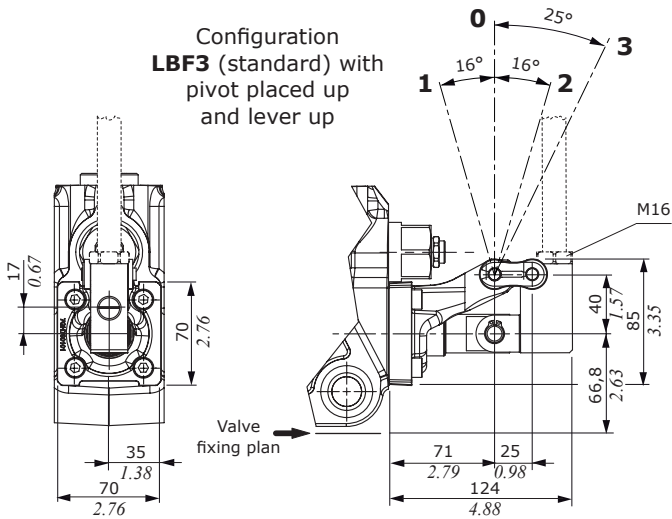
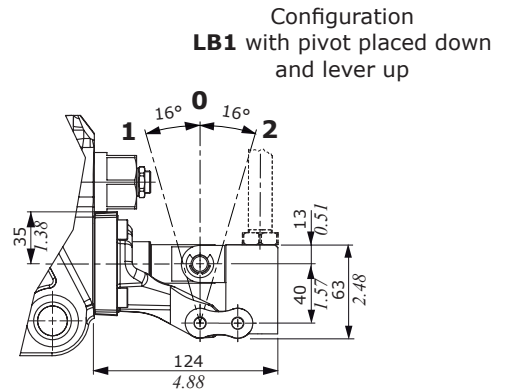
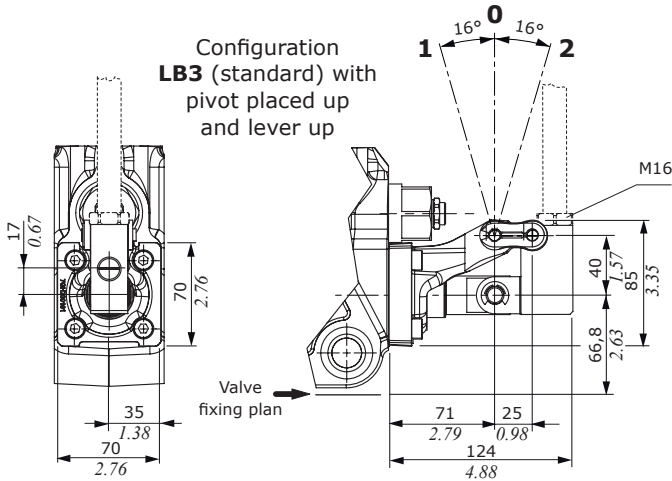

SLP and SLPF types: dust-proof plate

Type **SLP** for positioner type **8-11-13C-14C**. Type **SLPF** with seals for positioner type **13** and **14**. Dimensions are the same.

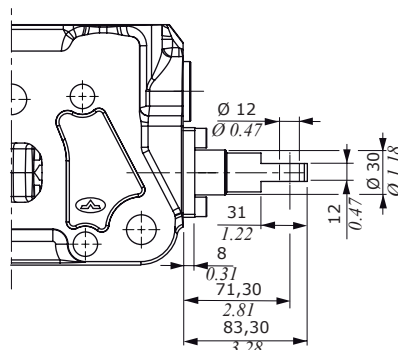

Proportional hydraulic control

8IM type

Double side proportional hydraulic control with spring return to neutral.

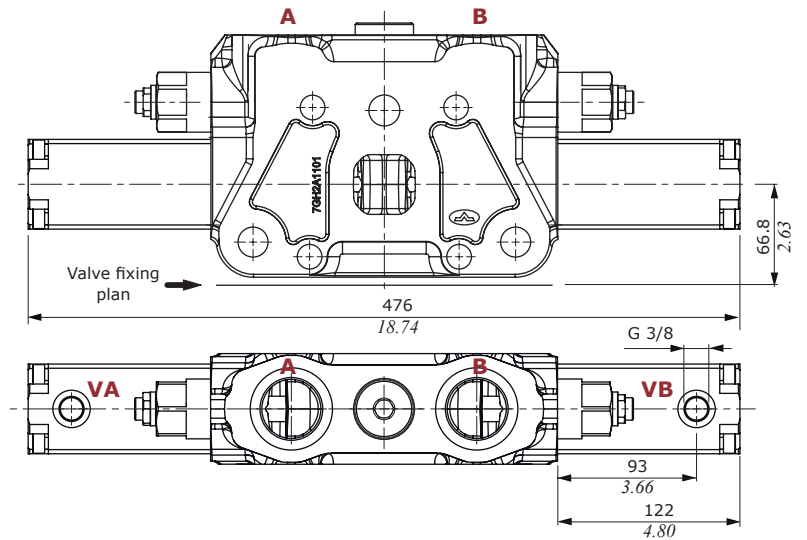
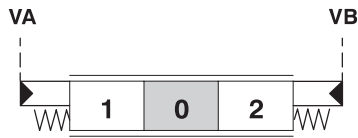

Pressure - stroke diagram

Referred to spool type 1

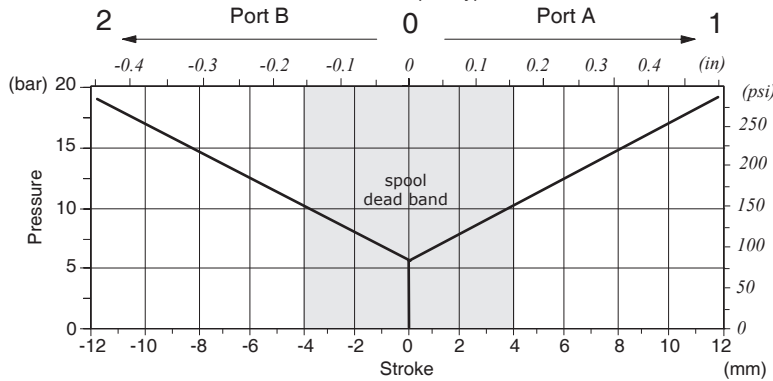

Pressure control curve on port VA and VB: type 033

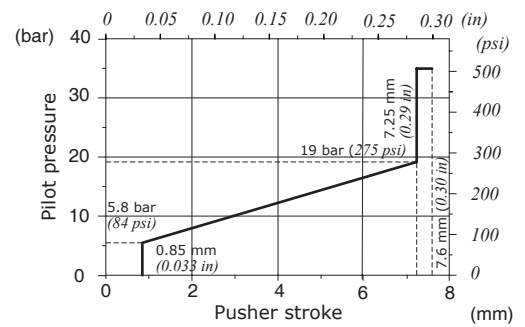

Features

Pilot pressure : min. 22 bar (320 psi)
max. 100 bar (1450 psi)

Complete controls

Proportional hydraulic control

13IM type

Double side proportional hydraulic control with spring return to neutral, for floating circuit.

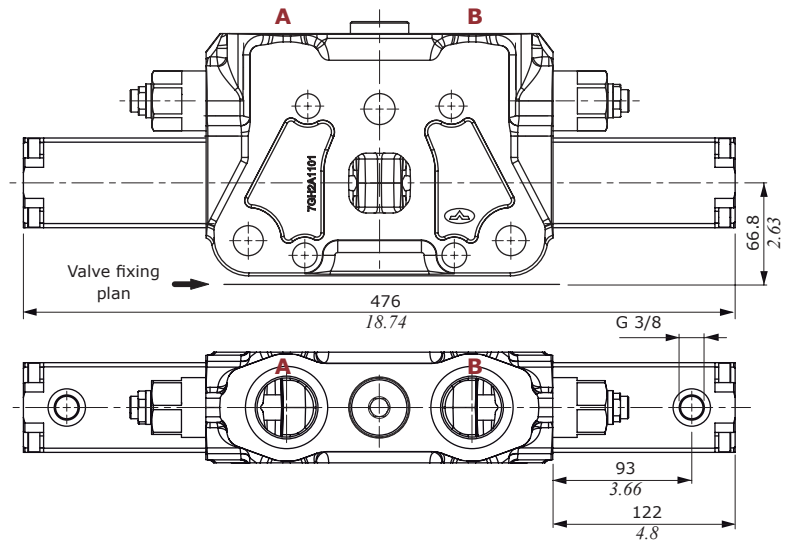
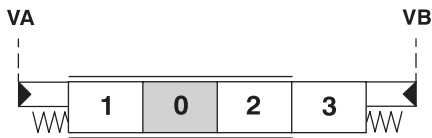

Pressure-stroke diagram

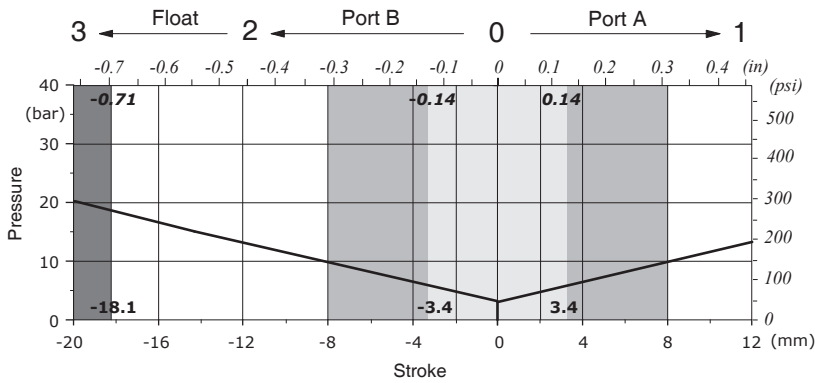

- Floating area
- Metering zone
- Spool dead band

Features

Pilot pressure : min. 22 bar (320 psi)
max. 100 bar (1450 psi)

Pressure control curve on position 1: 0010 type

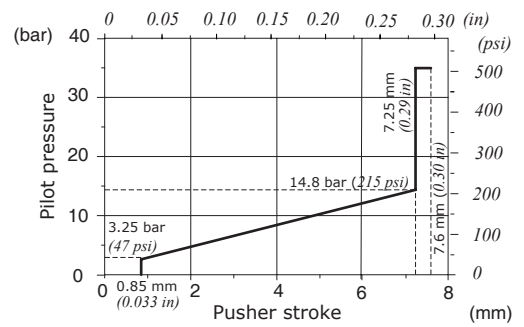

Pressure control curve on position 2 and float: E0096 type

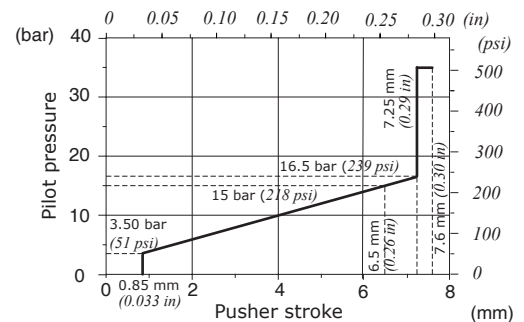

Pilot operated antishock valves

PX 1 (G3)

- Setting range
- 1 Mounted on port A
- 2 Mounted on port B
- 3 Mounted on port A and B

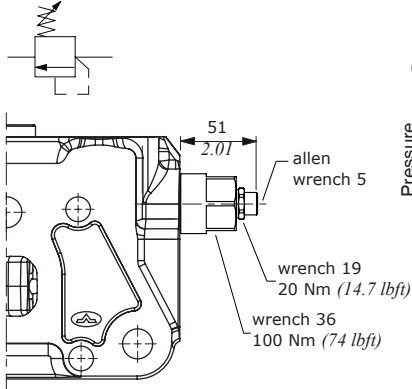

G2 setting range

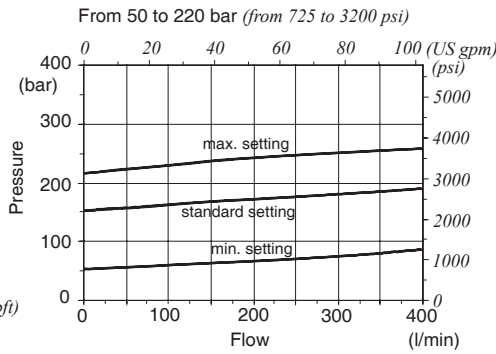

G3 setting range

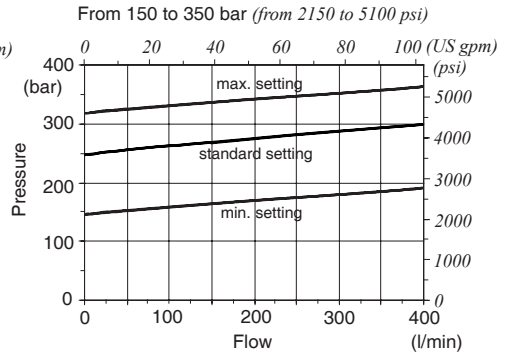

Antishock valves

P 1 (YG4)

- Setting range
- 1 Mounted on port A
- 2 Mounted on port B
- 3 Mounted on port A and B

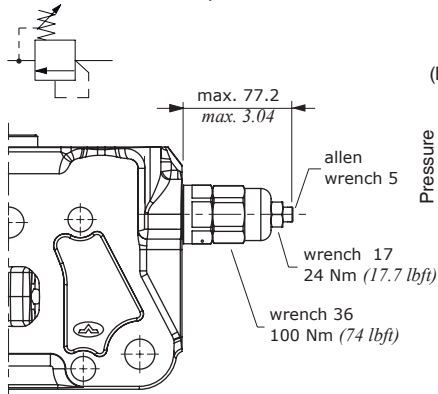

YG3 setting range

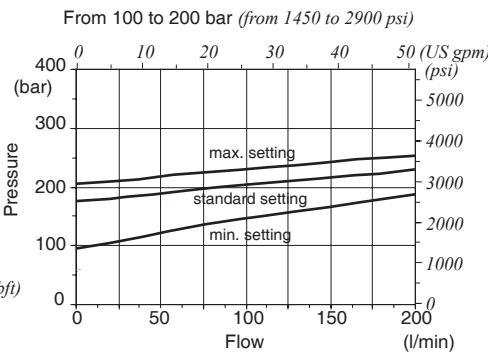

YG4 setting range

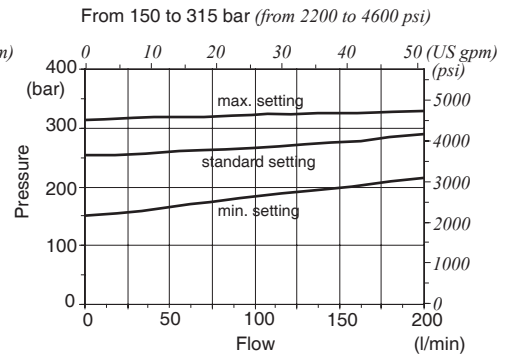

Antishock and anticavitation valves

UX 1

- 1 Mounted on port A
- 2 Mounted on port B
- 3 Mounted on port A and B

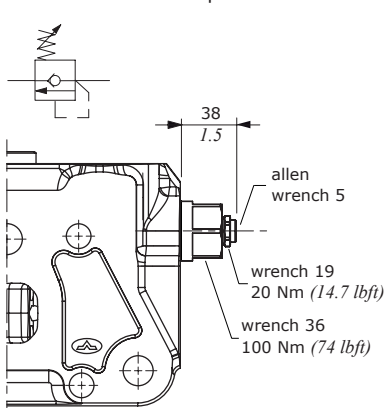

Setting range

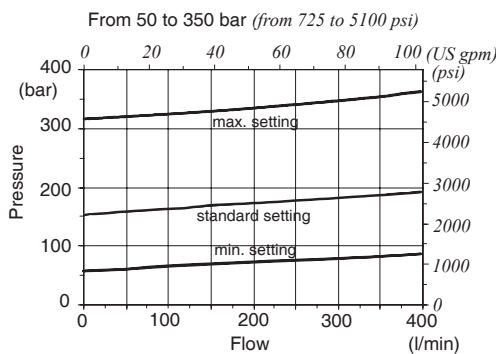

Pressure drop

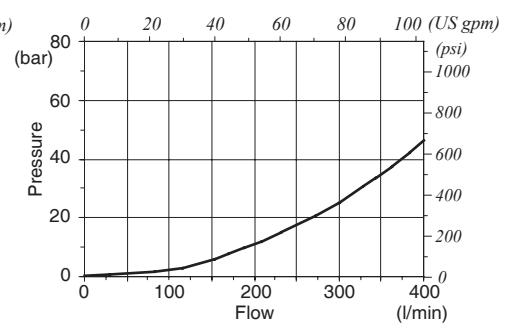

Anticavitation valves

C 1

- 1 Mounted on port A
- 2 Mounted on port B
- 3 Mounted on port A and B

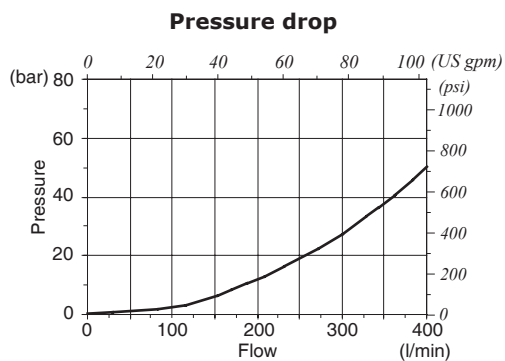
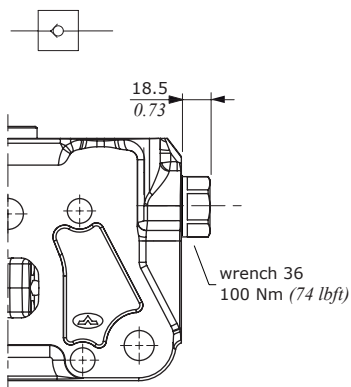

Valve blanking plugs

P 3 T

- 1 Mounted on port A
- 2 Mounted on port B
- 3 Mounted on port A and B

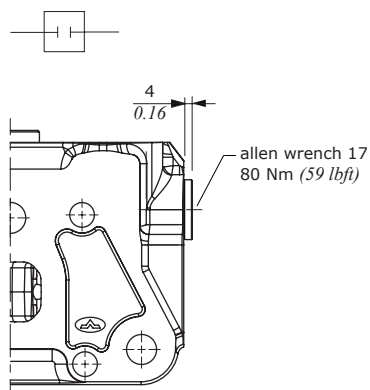

CS1 mid return manifold

Mid return manifold for directional valve with left and right inlet both; it allows 2 independent circuits with common outlet. DN 64 flange connection according to ISO 6162-1 type1.

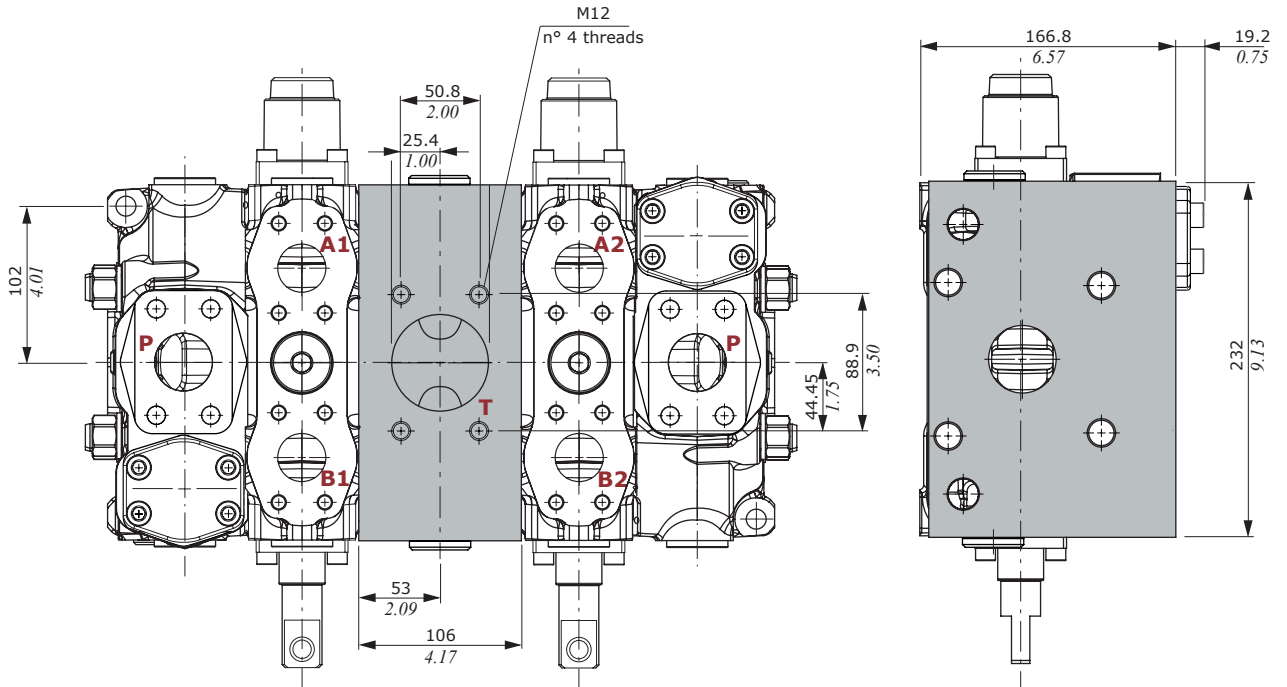

Hydraulic circuit

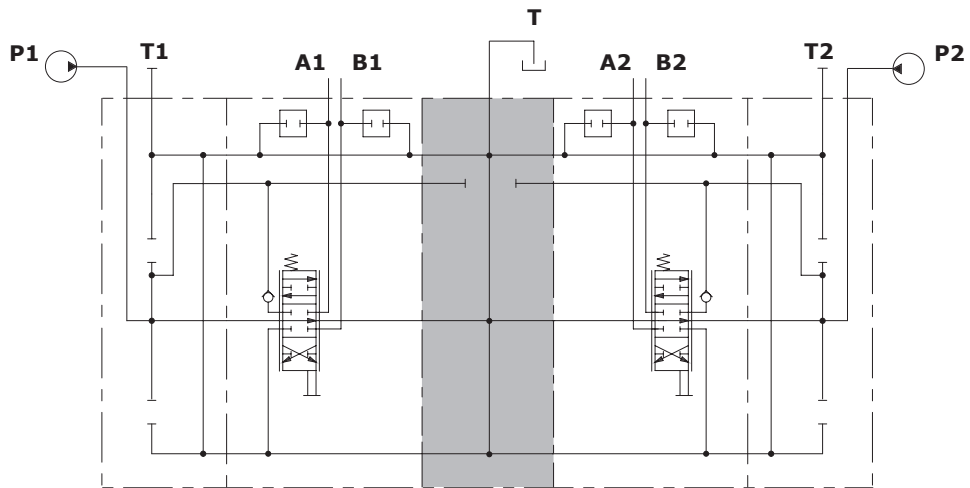

Description example:
SDS400/2/AD(SV)/18SLP/CS1/18SLP/BC(SV)

Parts ordering codes

FS SDS400 / RK - ...



Available configurations

- RC:** Side outlet
- RD:** Upper outlet
- RDA-FS3M:** Upper outlet with ISO flange connection
- RE:** Upper outlet and carry-over
- RE-FS3M:** As type RE with ISO flange connection
- RK:** Closed centre circuit: upper outlet, pressure line plugged

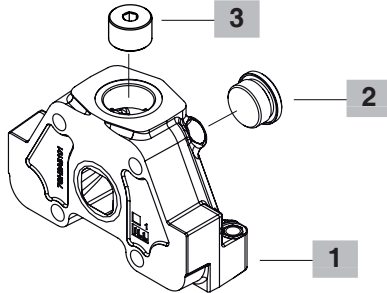

1 Outlet section body *

CODE	DESCRIPTION
3FIA240300	Outlet section body with threaded ports
3FIA240291	Outlet section body with ISO6162-1 type 1 flange
3FIA240290	Outlet section body with ISO6162-1 type 1 flange connection, without side port

2 Plug

CODICE	DESCRIZIONE	CODICE	DESCRIZIONE
XTAP717301	Tappo G 1-1/2	4FL1080210	Flangia cieca DN 32

3 Circuit options

CODE	QTY	DESCRIPTION
3TAP640251	1	M39x2 tapered plug for carry-over (RE) and closed centre (RK) options

4 Ports threading

page 4

Specify only if different from standard **BSP** thread (see page 4), for flange connection according to ISO 6162-1 type 1, indicate: **FS3M**.

NOTE (*) – Codes are referred to **BSP** thread.

Dimensional data and hydraulic circuit

RC type

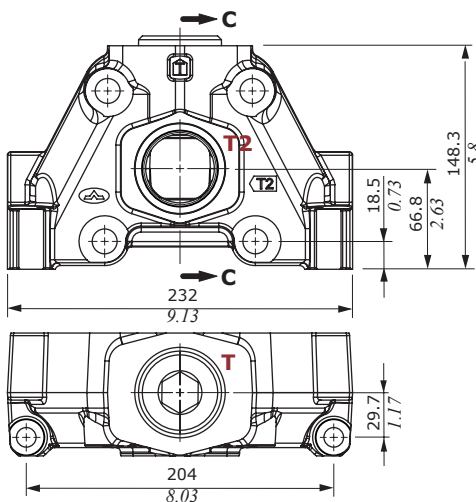

RC

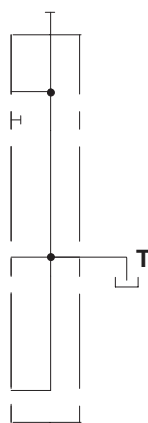

Section C-C

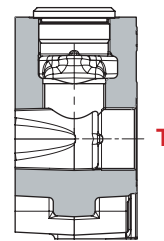

RD

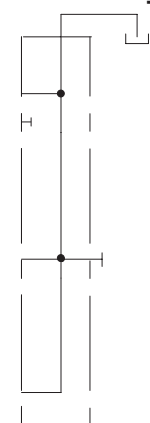

Section C-C

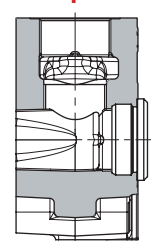

RE-FS3-M type (ISO flange connection)

Note: The outlet section body RDE is without side port.

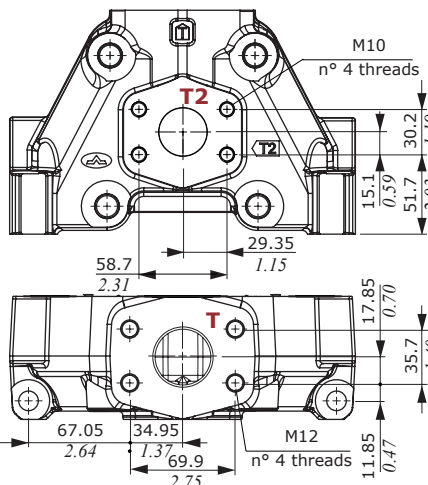

RE

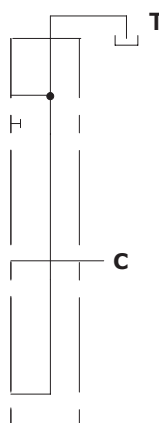

Section C-C

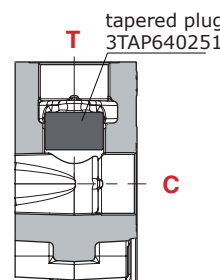

RK

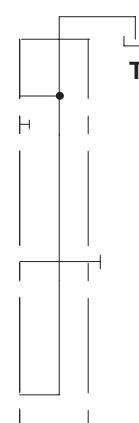

Section C-C

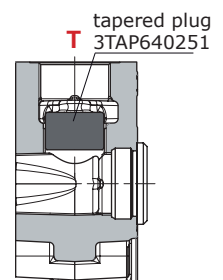

Installation and maintenance

The SDS400 valve is assembled and tested as per the technical specification of this catalogue.

Before the final installation on your equipment, follow the below recommendations:

- the valve can be assembled in any position; in order to prevent working section deformation and spool sticking mount the product on a flat surface;
- In order to prevent the possibility of water entering the lever box and spool control kit, do not use high pressure wash down directly on the valve;
- prior to painting, ensure plastic port plugs are tightly in place.

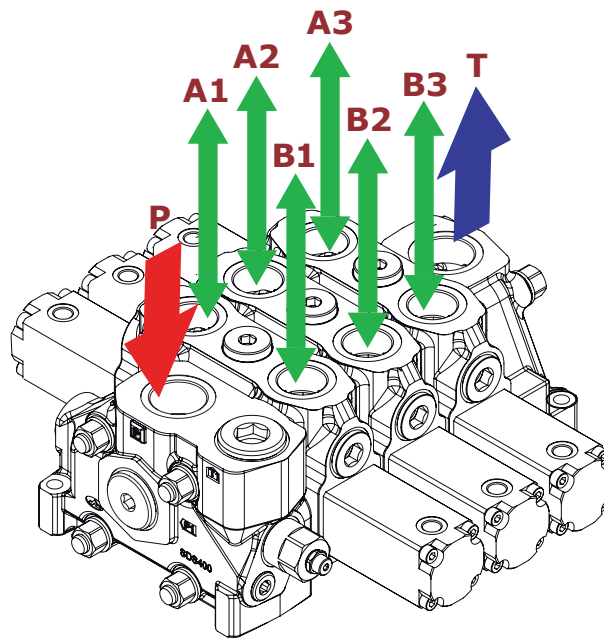

Fitting tightening torque - Nm / lbft

THREAD TYPE	port P	ports A, B	port T	Hydraulic pilot
BSP	G 1 1/2	G 1 1/4	G 1 1/2	G 3/8
With O-Ring seal	240 (177)	190 (140)	240 (177)	35 (25.8)
With copper washer	240 (177)	190 (140)	240 (177)	35 (25.8)
With steel and rubber washer	240 (177)	190 (140)	240 (177)	35 (25.8)
UN-UNF	1 7/8-12 (SAE 24)	1 5/8-12 (SAE 20)	1 7/8-12 (SAE 24)	3/4-16 (SAE 8)
With O-Ring seal	240 (177)	200 (147)	240 (177)	49 (36.1)
SAE J518 CODE 61 ISO 6162-1 type 1 (bolts threading)	1 1/2 [1/2-13 UNC] DN 38 [M12]	1 1/4 [7/16-14 UNC] DN 32 [M10]	1 1/2 [1/2-13 UNC] DN 38 [M12]	—
	62-79 (47.5-58.3)	48-62 (35.4-45.7)	62-79 (45.7-58.3)	—

NOTE – These torque are recommended. Assembly tightening torque depends on many factors, including lubrication, coating and surface finish. The manufacturer shall be consulted.

Coils

Types and ordering codes

Coil type	Voltage	Connectors		
		ISO4400	Deutsch DT	AMP JPT
BER	12VDC	4SLE001200	4SLE00202 4SLE001201 ⁽²⁾	4SLE001203
	24VDC	4SLE002400 4SLE302400 ⁽¹⁾	4SLE002402 4SLE002401 ⁽²⁾	4SLE002403
	48VDC	4SLE304800 ⁽¹⁾	-	-
	110VDC	4SLE311000 ⁽¹⁾	-	-
	220VDC	4SLE322000 ⁽¹⁾	-	-
	220VDC	4SL1032200 ⁽¹⁾	-	-
Mating connectors		4CN1009995	5CON140031	5CON003

Notes: (1) to use only with rectifier connector - (2) perpendicular type

Voltage	ISO 4400 mating connector with rectifier
	BER type coil
12VDC	-
24VDC	4CN3010240
48VDC	4CN3010480
110VDC	4CN3011100
220VDC	4CN3012200

Dimensions and features

BER type

ISO4400 connector

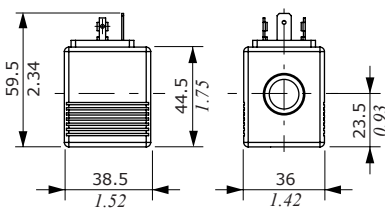

DEUTSCH connector (perpendicular type)

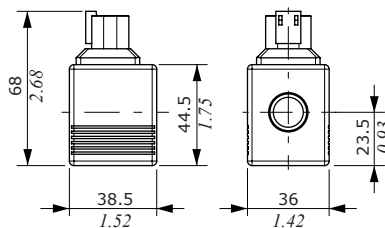

DEUTSCH connector (parallel type)

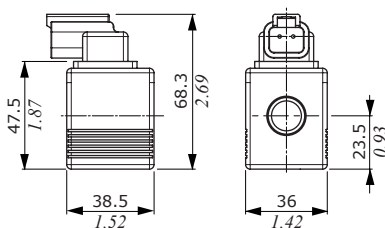

AMP JPT connector

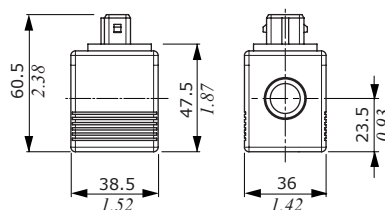

Features

- Nominal voltage tolerance . . . : ±10%
- Power rating : 19.3 W - 12VDC
: 19.2 W - 24VDC
: 19.2 W - 48VDC
: 19.2 W - 110VDC
: 19.3 W - 220VDC
- Nominal current : 1.61 A - 12VDC
: 0.80 A - 24VDC
: 0.40 A - 48VDC
: 0.17 A - 110VDC
: 0.09 A - 220VDC
- Coil insulation : Class H
: 180°C (356° F)
- Weather protection : IP65 - ISO4400
: IP69K - Deutsch DT
: IP65 - AMP JPT
- Insertion : 100%

7th edition October 2014

WWW.WALVOIL.COM



D1WWEB03E

