

SE.3.AN21.RS... ELECTRONIC CARDS FORMAT EUROCARD FOR POSITIONAL TRANSDUCER VALVES CONTROL



SE.3.AN21.RS...03

INSTRUCTIONS	CH. IX PAGE 14
OVERALL DIMENSIONS	CH. IX PAGE 14

The electronic cards type SE.3.AN.21.RS...serie 3 have been planned for controlling single and double solenoid proportional valves XDC3....serie 2 equipped with position transducer type LVDT. The card has a EUROCARD format for being assembled on a connector type DIN 41612 D 32. The output stage operates on the basis of the Pulse Width Modulation (PWM) and is subject to the current feedback so that it is possible to obtain an output solenoid current directly proportional to the input signal. The regulator is supplied with standard calibration for proportional valve control. The card is equipped with a control module type PI which compares the reference signal with the position transducer signal: the eventual error is used to optimize the regulation. It is possible to carry out further regulations by operating on the relative trimmers placed on the frontal panel (see picture).

- The connection between the card and the solenoid must be direct
- The common one of return to proportional solenoid must not be shared between other valve connections or electrical equipment worker.

CE Registered mark with reference to the electromagnetic compatibility.
European norms: EN50082-1 - General safety norm; EN50081-1 -Emission general norm.

ORDERING CODE

SE	Electronic card format EUROCARD DIN 41612
3	NG06
AN21	Analogic
RS	Closed loop valves with positional transducer type XDC.3 serie 2
16	Max. current at solenoid: 1.76 A
0	No variant
3	Serial No.

ADJUSTMENT PANEL FOR CARD

Fault	red – transducer fault signal
Power on	yellow – 24V DC power supply
Enable	green – card enable
Gain A	Solenoid A maximum current regulation
Offset A	Solenoid A offset current regulation
Gain B	Solenoid B maximum current regulation
Offset B	Solenoid B offset current regulation
Ramp Up	Ramp up regulation
Ramp Down	Ramp down regulation
Current A	Solenoid A current test point (1V=1A)
Current B	Solenoid B current test point (1V=1A)
Reference	Reference signal test point
Transducer	Transducer signal measurement point
Common 0V	Common zero

SE.3AN21RS1603
Made in Italy CE

ELECTRICAL CIRCUIT AND CONNECTIONS

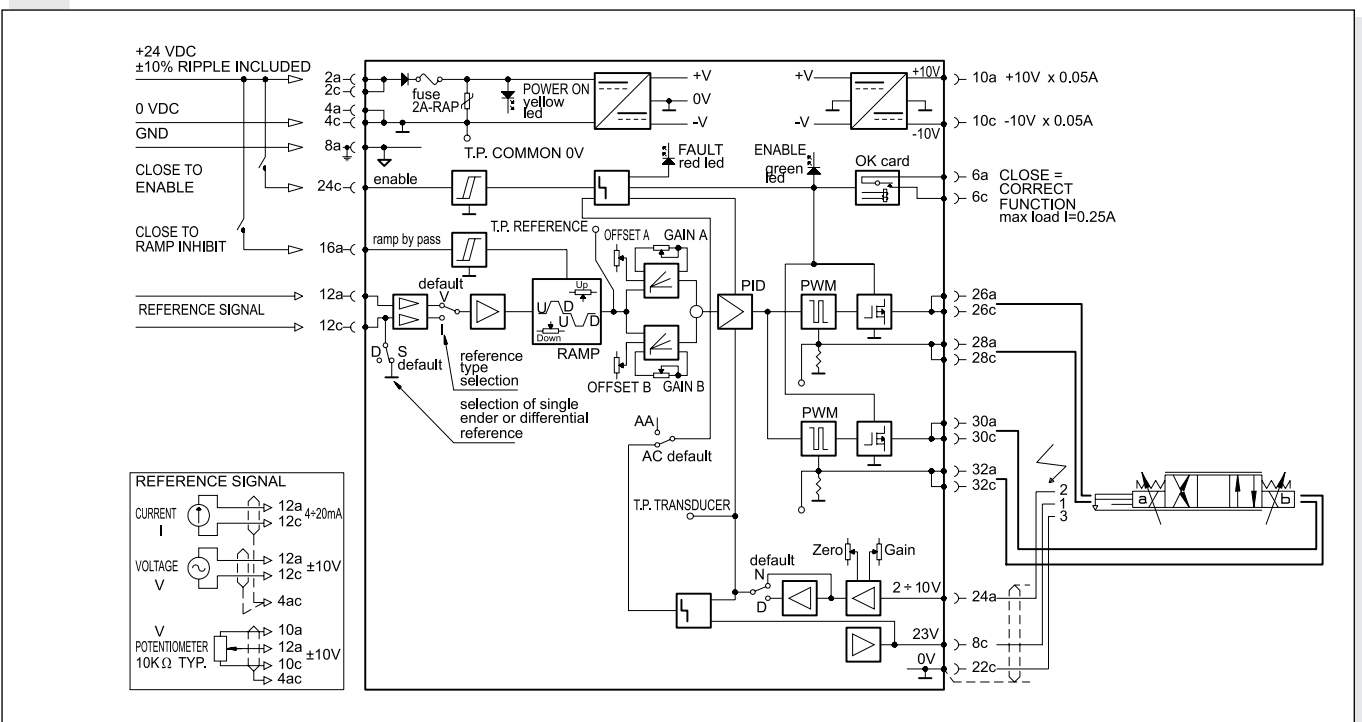

SE.3.AN.21.RS... ELECTRONIC CARDS FORMAT EUROCARD FOR POSITIONAL TRANSDUCER VALVES CONTROL



Instructions for use

For proportional valves with code
XDC.3.C..F... serie 2 (SE.3.AN21.RS.16...serie 3)

Power electric supply

24 VDC nominal
22÷30 VDC - rectified and stabilized (30W max.)
2A fast-acting fuse is fitted for power circuit protection.

Reference voltage

The card gives 2 stabilized voltage values: +10V 50mA (a10) and -10V 50mA (c10).

Available inputs

± 10V (a12, c12) presetted
4 ÷ 20mA (a12, c12) SW 1 bank:
select I for current reference signal.

Card enable (Enable)

Usually the card is not enable. For enabling it, apply in c24 a voltage between 22 and 30VDC. Green led signal.

Ramp exclusion

Ramps are usually on. In order to disable them apply a16 a voltage between 22 ÷ 30VDC.

Calibration procedure

Connect the card according to the scheme (See the preceding page). Set zero the reference potentiometer. Before applying the voltage, make sure that the hydraulic system does not move suddenly causing damages to people or things. Apply the voltage to the card: the green led will start blinking. Enable the card and disconnect the ramps (led "FAULT" off) and disable the ramps.

Minimum current regulation

A channel: put the reference signal on 3÷5% of the max. value. Turn the minimum current trimmer clockwise (I_{min} A) until the actuator moves; then turn the trimmer counterclockwise until the actuator stops.

B channel: repeat the above procedure for the A channel by operating on the I_{min} B trimmer for negative values of the reference signal.

Maximum current regulation

A channel: put the reference signal on the max. (positive) value and turn the gain trimmer (I_{max} A) slowly, until the max. speed requested is reached. Now the speed can be varied by changing the reference signal.

B channel: repeat the above procedure for the A channel by operating on the I_{max} B trimmer and by putting the reference signal on the max. negative value.

Ramp time calibration

Connect the ramps. The ramp time is the time which is necessary for going from the minimum current value to the max. current value and vice versa. The time can be set from a minimum value of 0.1 sec. (ramp excluded) up to a maximum value of 10 sec. (valve max. opening) whether downwards or upwards. By turning the trimmers clockwise the ramp time increases.

Notes:

The ramp down time influences the lock position of the actuator. By setting to zero the reference signal, the actuator keeps moving until the ramp time set (in a downward direction) has passed. For this reason it is necessary to carry out the adjustment carefully and properly.

The card block (FAULT) is automatically reset after that the error has been eliminated.

LVDT connection

See the preceding page:

- terminal 1 della LVDT c8 of the card
 - terminal 2 della LVDT a24 of the card
 - terminal 3 della LVDT c22 of the card
- Use screened cable with earth braid.

Solenoid current test point

On the frontal card panel: 1V = 1A

Command signal test point

Enables reading in voltage of reference signal sent to the card.

Reading is direct, but of opposite sign, with voltage reference while current conversation is: 4mA = +10V, 20mA = -10V.

Feedback signal test point

On the frontal card panel: ± 5V according to the spool position

Ambient temperature range

0° ÷ 50°C

Electric connections

The connections concerning the reference potentiometers must be carried out with a wire having a section of $\geq 0.75\text{mm}^2$.

It is advised to use a screened cable with earth braid.

OVERALL DIMENSIONS

9

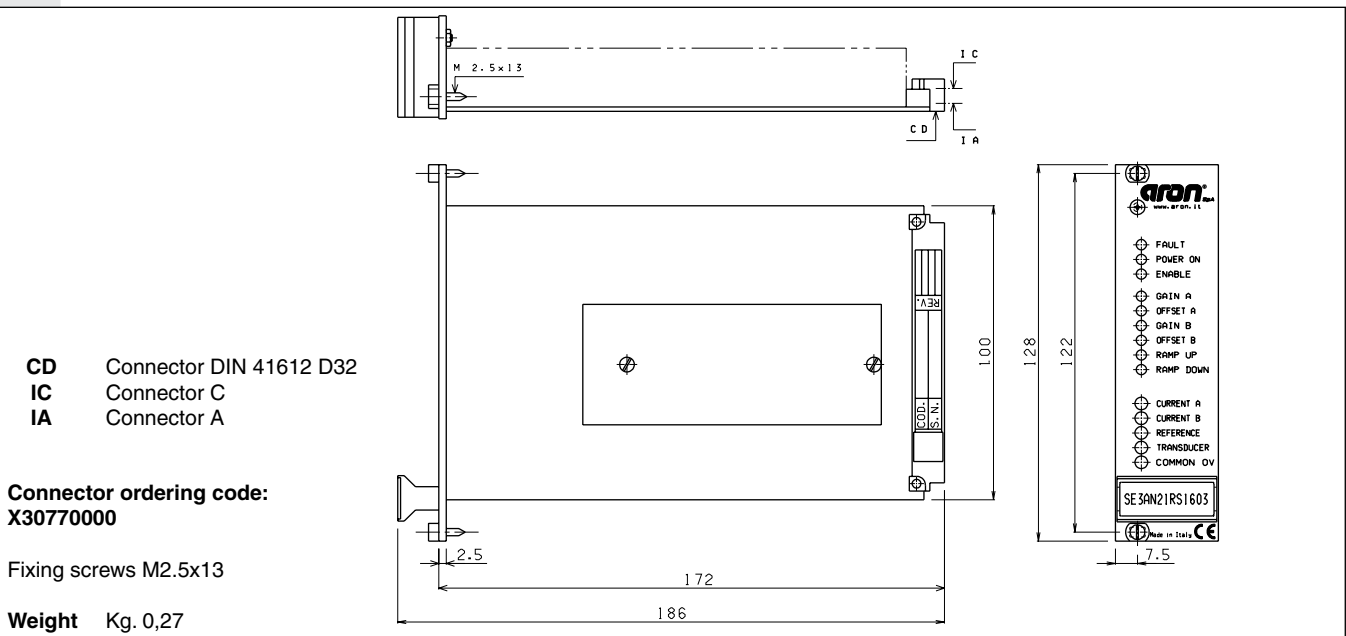

Brevini Fluid Power S.p.A
Via Moscova, 6 - 42124 Reggio Emilia (Italy)
Tel. +39 0522 270511 - Fax +39 0522 270660
www.brevinifluidpower.com

Product line by:

