



## SERBATOI OLIO IN ALLUMINIO / ALUMINIUM OIL TANK



### CARATTERISTICHE E DATI TECNICI / SPECIFICATIONS AND TECHNICAL DATA

CODICE CODE	DESCRIZIONE DESCRIPTION	A mm	PESO WEIGHT kg
AKSG000A201	Serbatoio in alluminio da 2 lt con spia di livello olio/2-liters aluminium tank with oil lever indicator	25	1.5
AKSG000A301	Serbatoio in alluminio da 3 lt con spia di livello olio/3-liters aluminium tank with light oil lever indicator	70	1.6
AKSG000A501	Serbatoio in alluminio da 5 lt con spia di livello olio/5-liters aluminium tank with light oil lever indicator	180	1.8
<b>A RICHESTA / UPON REQUEST</b>			
AKSG000A200	Serbatoio in alluminio da 2 lt senza spia di livello olio/2-liters aluminium tank without oil lever indicator	25	1.5
AKSG000A300	Serbatoio in alluminio da 3 lt senza spia di livello olio/3-liters aluminium tank without oil lever indicator	70	1.6
AKSG000A500	Serbatoio in alluminio da 5 lt senza spia di livello olio/5-liters aluminium tank without oil lever indicator	180	1.8

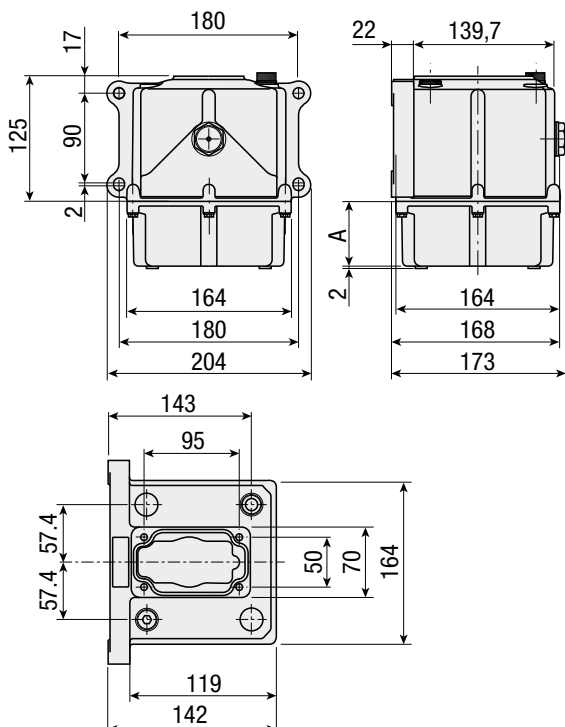

### ESEMPI DI INSTALLAZIONE DEL SERBATOIO STANDARD INSTALLATION EXAMPLES OF STANDARD TANK

