

HYDRAULIC MOTOR-BRAKES SW500B350V

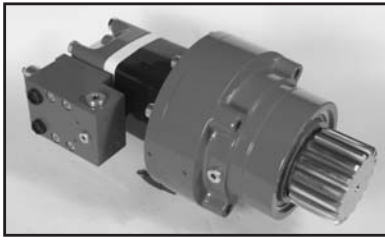

APPLICATION

- » Wheel drives
- » Conveyors
- » Rotators
- » Positioners
- » Winches
- » Swing drives
- » Door openers

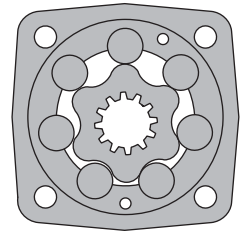

CONTENTS

Specification data	37
Dimensions and mounting	38
Permissible shaft loads	38
Function diagrams	39
Order code	39

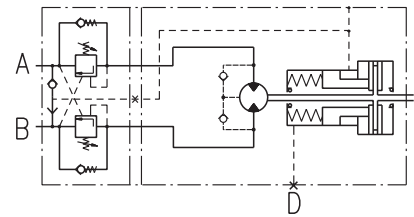

SPECIFICATION DATA

Type		SW500B350V
Displacement, cm ³ /rev [in ³ /rev]		475,3 [29]
Max. Speed, RPM	Cont.	16
	Int.*	25
Max. Torque, daNm [lb-in]	Cont.	82 [7260]
	Int.*	95 [8420]
Max. Output, kW [HP]	Cont.	0,9 [1.3]
	Int.*	2,4 [3.3]
Max. Pressure Drop, bar [PSI]	Cont.	125 [1800]
	Int.*	145 [2100]
Max. Oil Flow, lpm [GPM]	Cont.	8 [2]
	Int.*	12 [3]
Max. Return Pressure without Drain Line or Max. Pressure in Drain Line, bar [PSI]		100 [1450]
Min. Starting Torque, daNm [lb-in]	At max. press. drop Cont.	72 [6400]
	At max. press. drop Int.*	75 [6650]
Min. Speed**, RPM		5
Static Torque for the Brake***, daNm [lb-in]		164 [14 515]
Release Pressure ±10%, bar [PSI]	initial	25...28 [363...406]
	full	31 [449.6]
Max. Steering Pressure, bar [PSI]		245 [3553]
Max. Pressure in Drain Space for the Brake, bar [PSI]		0,5 [7]
Pilot Ratio for the Valve		4,25:1

* Intermittent operation: the permissible values may occur for max. 10% of every minute.

** For speeds of 5 RPM lower than given, consult factory or your regional manager.

*** Static torque is obtained at working pressure - 0 PSI [0 bar].

Space is filled with 125±20 cm³ [7.63±1.22 in³] mineral oil HLP (DIN 51524) or HM (ISO 6743/4).

DIMENSIONS AND MOUNTING

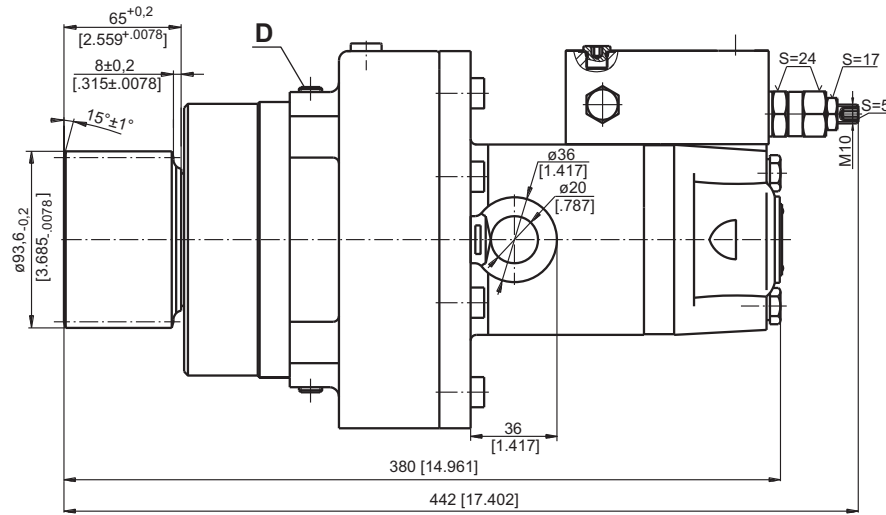
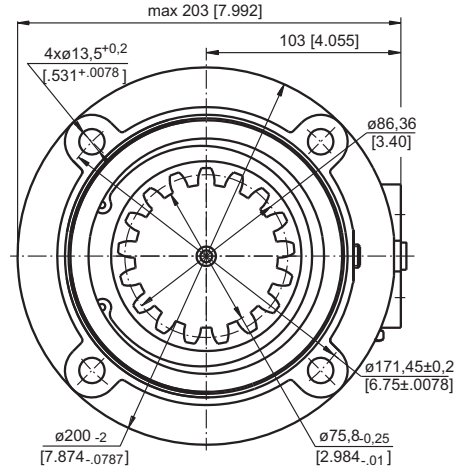
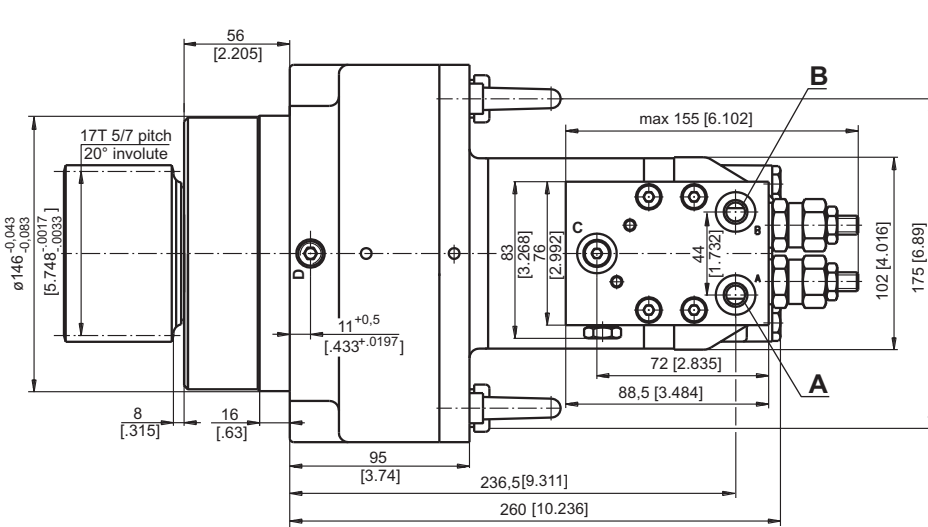

A,B: 7/16-20 UNF
D : 1/4-18 NPTF

Note: For different port's thread contact with "M+S Hydraulic".



PERMISSIBLE SHAFT LOADS

The curve applies to a B10 bearing life of 3000 hours at 40 RPM.

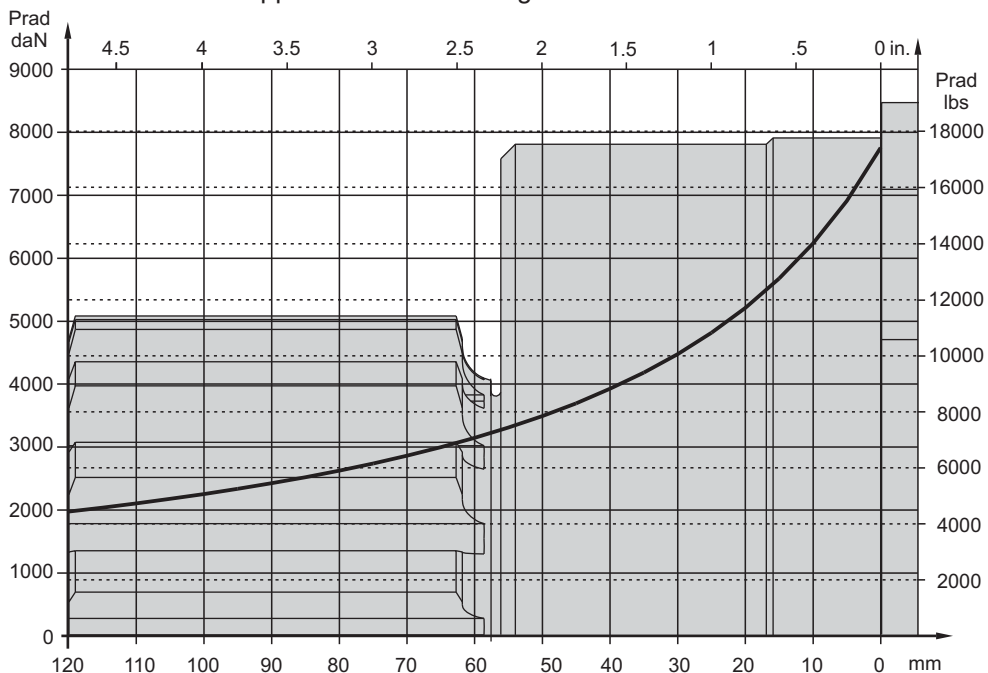

FUNCTION DIAGRAMS

SW 500

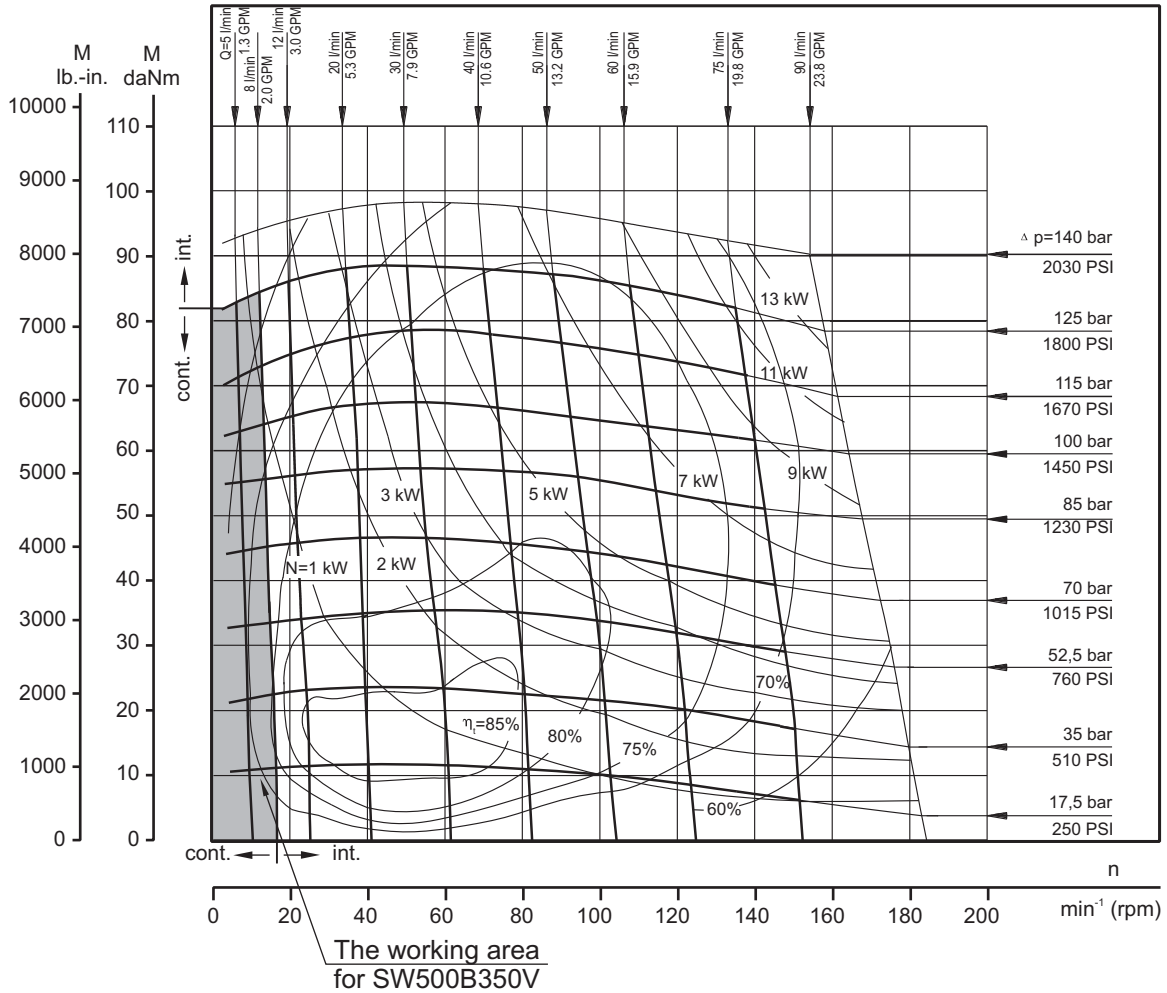

ORDER CODE

1	2	3	4	5	6	7	8
S	W	500	B	350	V		

- Pos.1 - Type
S - Motor MLHS
- Pos.2 - Displacement code
- Pos.3 - Brake
- Pos.4 - Brake Type

- Pos.5 - Shaft Extension
omit - 17T PITCH splined
- Pos.6 - Valve
- Pos.7 - Special Features (see page 64)
- Pos.8 - Design Series
omit - Factory specified

The motor-brakes are mangano-phosphatized as standard.

MOTOR-BRAKE SPECIAL FEATURES

Special Feature Description	Order Code	Motor type				
		B/MR	MT/B	MTM/B	SW	TW
Low Leakage	LL	○	-	○	-	-
Low Speed Valving	LSV	○	-	○	-	-
Free Running	FR	-	-	○		-
Reverse Rotation	R	○	○	○	-	-
Paint*	P	○	○	○	○	○
Corrosion Protected Paint*	PC	○	○	○	○	○
Special Paint**	PS	○	○	○	○	○
	PCS					
Check Valves		S	S	-	S	S

O	Optional
-	Not applicable
S	Standard

* Colour at customer's request.

** Non painted feeding surfaces, colour at customer's request.

APPLICATION CALCULATION

VEHICLE DRIVE CALCULATIONS

1. Motor speed: n, RPM

$$n = \frac{2,65 \times v_{km} \times i}{R_m} \quad n = \frac{168 \times v_{mi} \times i}{R_{in}}$$

v_{km} - vehicle speed, km/h;

v_{mi} - vehicle speed, mil/h;

R_m - wheel rolling radius, m;

R_{in} - wheel rolling radius, in;

i - gear ratio between motor and wheels.

If no gearbox, use $i=1$.

2. Rolling resistance: RR, daN [lbs]

The resistance force resulted in wheels contact with different surfaces:

$$RR = G \times \rho$$

G - total weight loaded on vehicle, daN [lbs];

ρ - rolling resistance coefficient (Table 1).

Table 1

Rolling resistance coefficient In case of rubber tire rolling on different surfaces	
Surface	ρ
Concrete- faultless	0.010
Concrete- good	0.015
Concrete- bad	0.020
Asphalt- faultless	0.012
Asphalt- good	0.017
Asphalt- bad	0.022
Macadam- faultless	0.015
Macadam- good	0.022
Macadam- bad	0.037
Snow- 5 cm	0.025
Snow- 10 cm	0.037
Polluted covering- smooth	0.025
Polluted covering- sandy	0.040
Mud	0.037÷0.150
Sand- Gravel	0.060÷0.150
Sand- loose	0.160÷0.300

3. Grade resistance: GR, daN [lbs]

$$GR = G \times (\sin \alpha + \rho \times \cos \alpha)$$

α - gradient negotiation angle (Table 2)

Table 2

Grade %	α Degrees	Grade %	α Degrees
1%	0° 35'	12%	6° 5'
2%	1° 9'	15%	8° 31'
5%	2° 51'	20%	11° 19'
6%	3° 26'	25%	14° 3'
8%	4° 35'	32%	18°
10%	5° 43'	60%	31°

4. Acceleration force: FA, daN [lbs]

Force FA necessary for acceleration from 0 to maximum speed v and time t can be calculated with a formula:

$$FA = \frac{v_{km} \times G}{3,6 \times t}, [daN] \quad FA = \frac{v_{mi} \times G}{22 \times t}, [lbs];$$

FA - acceleration force, daN [lbs];

t - time, [s].

5. Tractive effort: DP, daN [lbs]

Tractive effort DP is the additional force of trailer. This value will be established as follows:

-acc.to constructor's assessment;

-as calculating forces in items 2, 3 and 4 of trailer; the calculated sum corresponds to the tractive effort requested.

6. Total tractive effort: TE, daN [lbs]

Total tractive effort TE is total effort necessary for vehicle motion; that the sum of forces calculated in items from 2 to 5 and increased with 10 % because of air resistance.

$$TE = 1,1 \times (RR + GR + FA + DP)$$

RR - force acquired to overcome the rolling resistance;

GR - force acquired to slope upwards;

FA - force acquired to accelerate (acceleration force);

DP - additional tractive effort (trailer).

7. Motor Torque moment: M, daNm [lb-in]

Necessary torque moment for every hydraulic motor:

$$M = \frac{TE \times R_m [R_{in}]}{N \times i \times \eta_m}$$

N - motor numbers;

η_m - mechanical gear efficiency (if it is available).

8. Cohesion between tire and road covering: M_w , daNm [lb-in]

$$M_w = \frac{G_w \times f \times R_m [R_{in}]}{i \times \eta_m}$$

To avoid wheel slipping, the following condition should be observed $M_w > M$

f - frictional factor;

G_w - total weight over the wheels, daN [lbs].

Table 3

Surface	Frictional factor f
Steel on steel	0.15 ÷ 0.20
Rubber tire on polluted surface	0.5 ÷ 0.7
Rubber tire on asphalt	0.8 ÷ 1.0
Rubber tire on concrete	0.8 ÷ 1.0
Rubber tire on grass	0.4

9.Radial motor loading: P_{rad} , daN [lbs]

When motor is used for vehicle motion with wheels mounted directly on motor shaft, the total radial loading of motor shaft P_{rad} is a sum of motion force and weight force acting on one wheel.

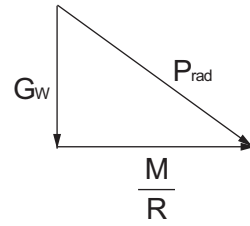

- G_w - Weight held by wheel;
- P_{rad} - Total radial loading of motor shaft;
- M/R - Motion force.

$$P_{rad} = \sqrt{G_w^2 + \left(\frac{M}{R}\right)^2}$$

In accordance with calculated loadings the suitable motor from the catalogue is selected.

DRAINAGE SPACE AND DRAINAGE PRESSURE

Advantages in oil drainage from drain space: Cleaning; Cooling and Seal lifetime prolonging.

