

Serv-Clip® Type 1 for mounting on pressurized pipes

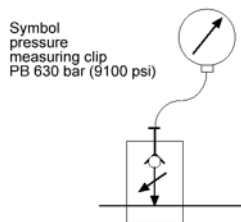

Test **sensors** (flow rate, leakage, temperature, pressure) in combination with **Serv-Clip Type 2** (for mounting on non-pressurized pipes).

Order references

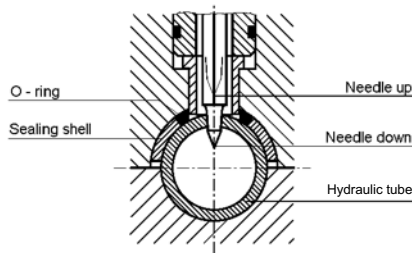
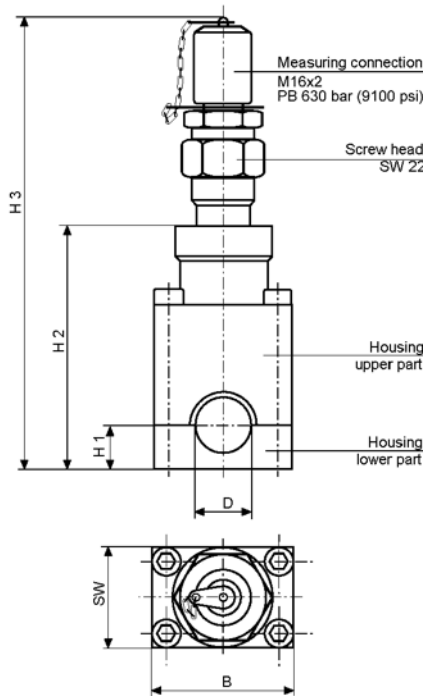
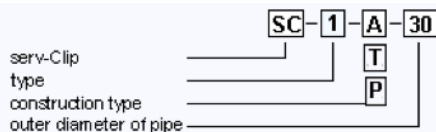

- ◆ Quick, simple and cheap installation of a measuring connection in approx. 3 minutes.
- ◆ Installation on steel or stainless steel pipes – NO CUTTING PIPES
- ◆ Installation without switching off the system
- ◆ No contamination of hydraulic oil through metal particles
- ◆ Installation of manometers, sensors and switches with 1/4" screw possible. Incl. valve M16x2
- ◆ You need a jaw and Allen wrench for the installation only
- ◆ For use up to 630 bar (9100 psi) working pressure
- ◆ **Serv-Clip** is registered trade mark of Serv-Clip USA LLC

Description

The patented pressure measuring clip is simply screwed onto the cleaned surface of the **pressurized hydraulic carbon steel or stainless steel tube**.

It is not necessary to interrupt the operation of the plant.

A specially shaped steel needle is inserted through the wall of the tube above the screw head.

The screw head is then screwed back. The created hole is then open, and it is possible to measure the pressure immediately.

This connection is simple, quick and safe to install. The procedure only takes a few minutes. No special tools are required to install the Serv-Clip. The system is completely leakproof. Any pollution of the hydraulic liquid is impossible.

It is not necessary to dismantle the measuring clip on completion of the measuring procedure in order to save costs. The operational safety of the hydraulic system is maintained. The measuring point remains permanently available for taking measurements.

Materials

Housing: 9SMnPb28K

Sealing Shell: St. 37.4

Measuring Needle: 58CrV4

O-Ring: Viton

Screw Head: 9SMnPb28k

A=metric	
Outer-Ø	Ordering code
10 mm	SC-1-A-10
12 mm	SC-1-A-12
14 mm	SC-1-A-14
15 mm	SC-1-A-15
16 mm	SC-1-A-16
18 mm	SC-1-A-18
20 mm	SC-1-A-20
22 mm	SC-1-A-22
30 mm	SC-1-A-30
35 mm	SC-1-A-35
38 mm	SC-1-A-38
42 mm	SC-1-A-42

T=Tube inch		
Outer-Ø	Outer-Ø	Ordering code
3/8"	9.52 mm	SC-1-T-3/8"
1/2"	12.7 mm	SC-1-T-1/2"
5/8"	15.90 mm	SC-1-T-5/8"
3/4"	19.05 mm	SC-1-T-3/4"
1"	25.40 mm	SC-1-T-1"
1 ¼"	31.75 mm	SC-1-T-1 ¼"
1 ½"	38.10 mm	SC-1-T-1 ½"
2"	50.80 mm	Available in Type 2

P=Pipe inch				
Internal-Ø	Outer-Ø	Schedules		Ordering code
		60	180	
1/4"	13.5 mm	3.0	-	Available in Type 2
3/8"	17.2 mm	3.2	-	Available in Type 2
1/2"	21.4 mm	3.7	4.7	SC-1-P-1/2"
3/4"	26.9 mm	3.9	(*) X	SC-1-P-3/4"
1"	33.7 mm	4.5	(**) X	SC-1-P-1"
1 1/4"	42.4 mm	4.8	6.4	Available in Type 2
1 1/2"	48.3 mm	5.0	7.1	Available in Type 2
2"	60.3 mm	5.5	X	Available in Type 2
2 1/2"	76.1 mm	7.0	X	Available in Type 2
3"	88.9 mm	7.6	X	Available in Type 2

(*) 5.6 mm and (**) 6.4 mm available in Type .2



Safety Instructions

To ensure a correct and safe installation of the Serv-Clip please read safety and installation instructions referring to pressure measuring clips. SC-1-A-(mm) / T (tube OD) / P (pipe ID).

The indicated measuring clips Serv-Clip are exclusively for use in fluid-technical plants. The field of application is Tubes with technical oils, like hydraulic systems and lubrication oil supply or cooling plants.

Use in water. Air, and gas tubes is prohibited.

We reserve ourselves the right to modifications which are useful for any further technical development.

Installation of the Serv-Clip

Prior to the installation a check must take place to ensure that the outer diameter of the tube concerned and that of the selected Serv-Clip match. It is not permitted to install a Serv-Clip onto tubes that are seriously rusted or seem to be cracked.

Furthermore, it is a precondition that the tube system should be laid and fixed in such a way that the Serv-Clip is not affected by any additional burdens, stress and tensions. Tubes are to be laid so as to be adequately stable in relation to the operational conditions and they are to be equipped with fixed points.

Then the part of the tube where the installation is to take place has to be cleaned and all paint and paint remains are to be removed. The tube should be smooth, clean and dry at this point.

Installation will take approx. 3 minutes only, no cutting pipelines.

Then the housing, consisting of two parts, is positioned on the tube with the help of an Allen wrench 6 mm. The four housing screws are now fastened firmly.

The last step is to turn the screw head to the right to the stop position, using a jaw wrench (without extension SW22). The screw head is then screwed back.

Thus, the connection has been made and the measuring point can be put to permanent use.

Tolerances of the outer diameter of the tube according to DIN 2391

Tube Ø	Permitted Deviation
10 mm, 3/8"	± 0.10 mm
12-30 mm, 1/2", 5/8", 3/4", 1"	± 0.08 mm
35-38 mm, 1-1/4", 1-1/2"	± 0.15 mm
42 mm	± 0.20 mm

Pressure Capacity

PB 630 bar (9,100 psi) the indications with regard to pressure and safety are based on the installation according to this data leaflet.

Working Temperature

Steel: -40 to +120°C

O-Ring in Viton: -25 to +200°C

The indicated temperature limits for sealing materials are guidelines as these temperature limits may be influenced considerably by the medium.

Clip Material	Temperature Range	Pressure Reduction
Steel	-40 to +120°C	None

Pressure reduction

Required pressure reduction due to the material in comparison to catalogue details in the case of increased or reduced temperatures.

If there are divergent definitions for permissible pressures, safety margins, temperatures and, if necessary, applicable pressure reductions due to standards, regulations or approvals for specific applications, the information provided by them is obligatory.

Nominal pressures (PN) and working pressures (PE) detained in the catalogue are max. permissible working pressures including pressures peaks, whereby the temperature limits and pressure reductions detailed in the table above must be taken into consideration.

Functional safety under stationary load

Types with PN indications: 4 times

Types with PB indications: 2.5 times

Test *sensors* (flow rate, leakage, temperature, pressure) in combination with *Serv-Clip Type 2* (for mounting on non-pressurized pipes).

Installation Instructions

Good maintenance practices for the Condition Monitoring
INSTALLATION IN 3 MINUTES

serv-Clip 1 (1/4" screw)

for mounting on pressurized pipes

serv-Clip 2 (3/8" screw)

for mounting on non-pressurized pipes

Required tools: Allen wrench 6mm and jaw wrench sw22



1 Installation location



5 screw down
clamp bolts



1 Installation location



5 screw the valve
to the right until it stops
then screw it to the left

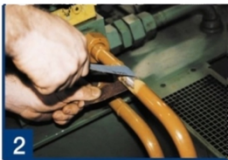

2 remove paint



6 screw the valve
to the right until it stops
then screw it to the left



2 remove paint and
clean pipe



6 remove stirrup
and needle



3 clean pipe



7 ready to measure



3 clamp SC onto pipe



7 screw valve



4 clamp SC onto pipe



4 screw down
clamp bolts



8 ready to measure

- No contamination
- No leakages
- Vibration certificate

Installation

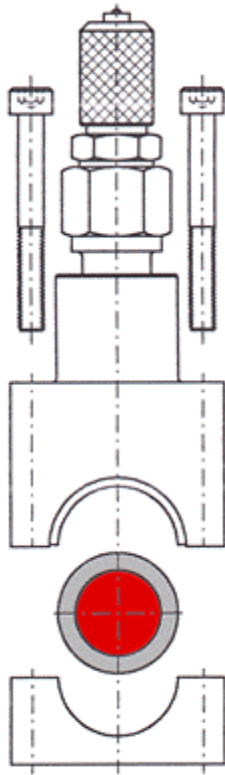

1. Place in position

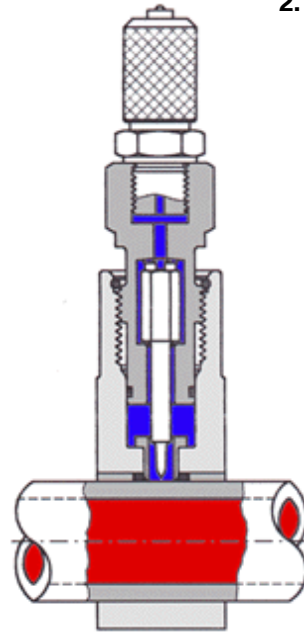

2. Screw down

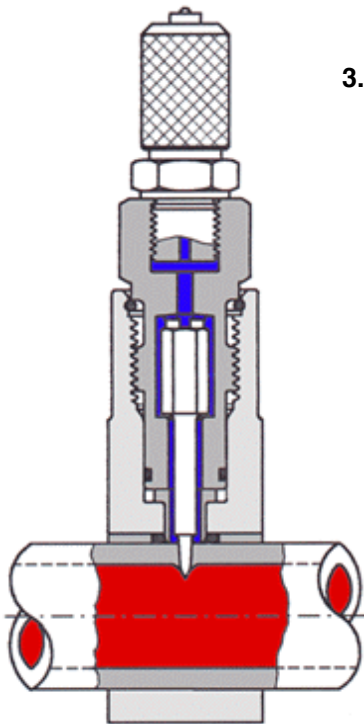

3. Insert

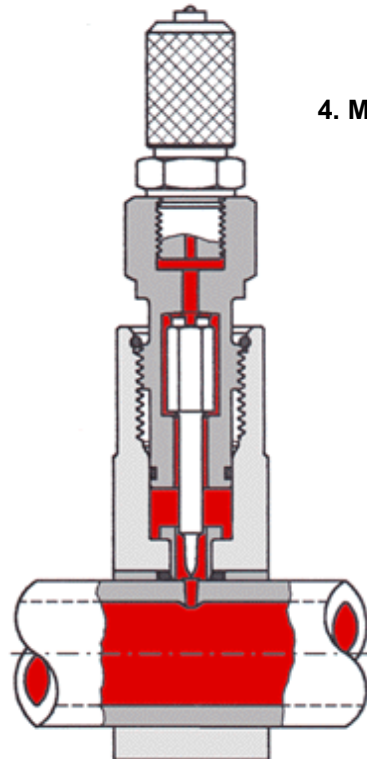

4. Measure