

**TP9237**

TP- CEC -B-DVG/US/

Evaluation systems

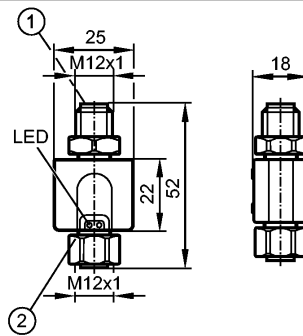

1: connection for voltage supply and output signals  
 2: connection for temperature sensor



**Product characteristics**

Measured signal converter for temperature sensors

for Pt100 and Pt1000 measuring elements

Analog output 0...10 V

Measuring range: -50...300 °C / -58...572 °F

Factory setting: 0...100 °C

**Electrical data**

Electrical design	DC
Operating voltage [V]	18...32 DC
Protection class	III
Reverse polarity protection	yes

**Outputs**

Output	Analog output 0...10 V
Output function	0...10 V analog
Short-circuit protection	yes (non-latching)
Overload protection	yes
Analog output	0...10 V; Rmin: 2000 Ω

**Measuring / setting range**

Measuring range	-50...300 °C	-58...572 °F
Factory setting	0...100 °C	

**Accuracy / deviations**

Analog output [K]	± 0.3 + (± 0.1 % MS)
Temperature coefficients (in % of the span per 10 K)	0.1
Measured value via IO-Link [K]	± 0.3 + (± 0.1 % MS)

**Reaction times**

Power-on delay time [s]	1
Measuring / display cycle [ms]	100
Integrated watchdog	yes

**Interfaces**

IO-Link Device	
Transfer type	COM2 (38.4 kBaud)
IO-Link revision	1.1

**Environment**

**TP9237**

TP- CEC -B-DVG/US/

**Evaluation systems**

Ambient temperature	[°C]	-25...70
Storage temperature	[°C]	-40...85
Protection		IP 67

**Tests / approvals**

EMC		EN 61326-1
Shock resistance	DIN IEC 68-2-27:	50 g (11 ms)
Vibration resistance	DIN IEC 68-2-6:	20 g (10...2000 Hz)
MTTF	[Years]	505.11

**Mechanical data**

Housing materials	PA PACM 12 (TROGAMID); PET; sealing: FPM (Viton); nut: stainless steel 316L / 1.4404; connector: TPU (urethane)	
Weight	[kg]	0.04

**Electrical connection**

Connection	M12 connector; gold-plated contacts
------------	-------------------------------------

**Wiring**

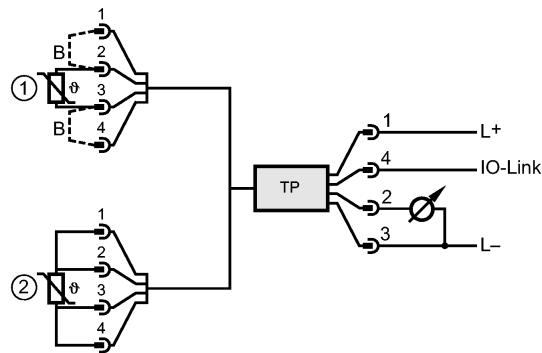

- 1: Two-wire sensor
- 2: Four-wire sensor
- B: bridge

**Remarks**

Remarks	cULus - Class 2 source required The measuring range can be scaled: -50... 300 °C / -58...572 °F MS = set measuring span
---------	--

Pack quantity	[piece]	1
---------------	---------	---