

**TPV 1500**

**VARIABLE DISPLACEMENT AXIAL PISTON PUMP**

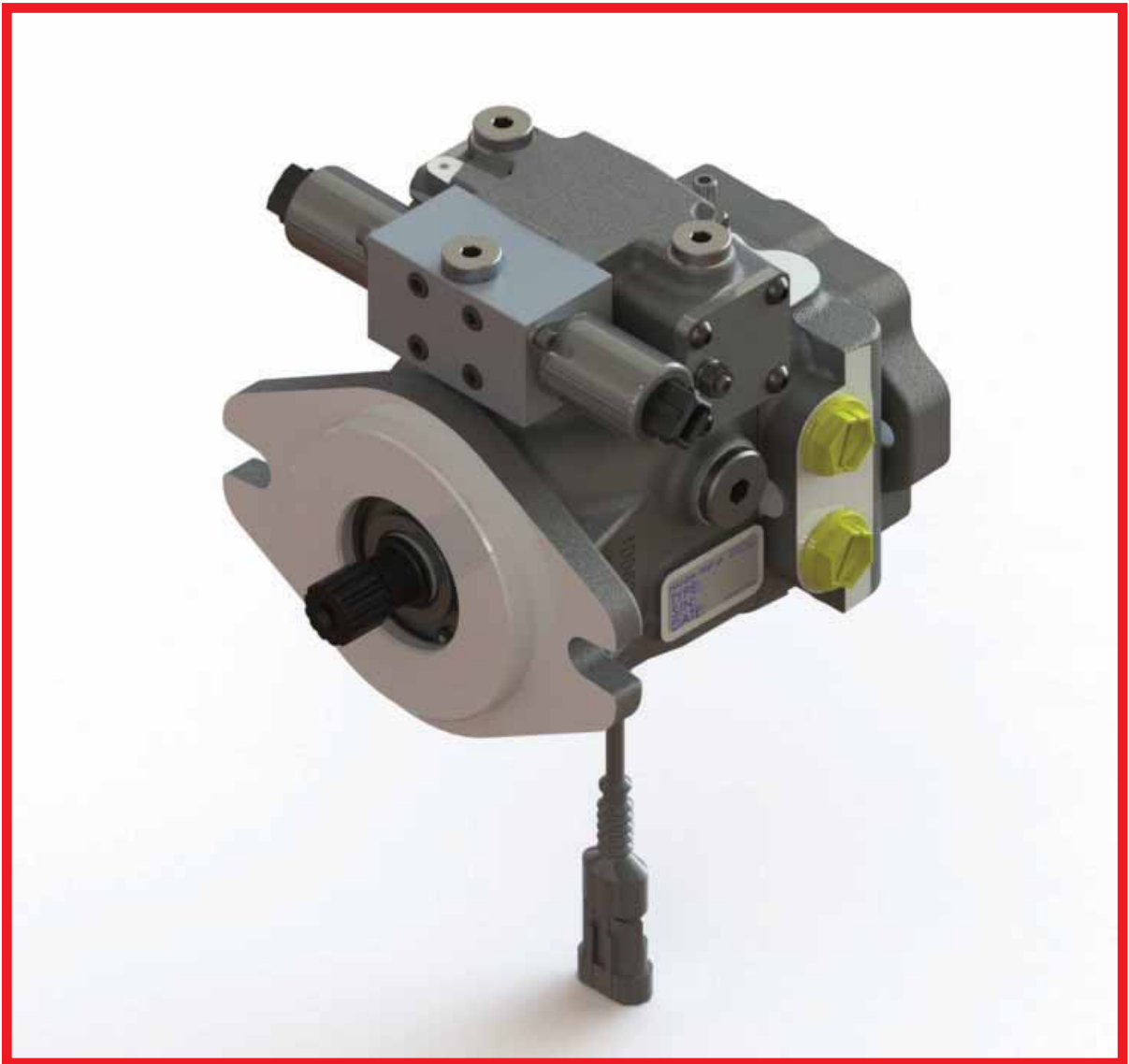

ORDER CODE \_\_\_\_\_

1500	TPV	17-9	CR	SS3	F2	SHI	OA	10	06	SA-R	000	1	00
0	1	2	3	4	5	6	7	8	9	10	11	12	13

Pag.

1500	<b>0 - Pump series</b> = Pump TPV 1500	
TPV	<b>1 - Pump model</b> = Closed loop circuit pump	
	<b>2 - Pump displacement</b> 17-9 = 17,6 cm <sup>3</sup> /n      18-9 = 18,7 cm <sup>3</sup> /n      19-9 = 19,9 cm <sup>3</sup> /n      21-9 = 21,1 cm <sup>3</sup> /n	
CR	<b>3 - Rotation</b> = Clockwise rotation (right)	
CC	= Counter-clockwise rotation (left)	
SS3	<b>4 - Shaft (mounting side)</b> = Splined shaft SAE-B (ANSI B92.1A - 13T - 16/32 D.P.)	19
F2	<b>5 - Mounting flange</b> = SAE-B 2 bolt - pilot diam. 101,6 mm	19
SHI	<b>6 - Controls</b> = Hydraulic servo control	20
SHIC	= Compact hydraulic servo control	22
SEI1.3	= Electro-proportional servo control 12V DC (AMP junior timer connector)	24
SEI2.3	= Electro-proportional servo control 24V DC (AMP junior timer connector)	24
SEI1.3D	= Electro-proportional servo control 12V DC (Deutsch connector)	27
SEI2.3D	= Electro-proportional servo control 24V DC (Deutsch connector)	27
SHIX	= Hydraulic servo control with feed back	30
SMIX	= Mechanical lever servo control with feed back	32
SEIX1.3	= Electro-proportional servo control with feed back 12V DC (AMP junior timer connector)	34
SEIX2.3	= Electro-proportional servo control with feed back 24V DC (AMP junior timer connector)	34
SEIX1.3D	= Electro-proportional servo control with feed back 12V DC (Deutsch connector)	37
SEIX2.3D	= Electro-proportional servo control with feed back 24V DC (Deutsch connector)	37
OA	<b>7 - Control devices position</b> = Position A	
	<b>8 - Relief valve pressure setting</b> 10 = 10 MPa      15 = 15 MPa      18 = 18 MPa      20 = 20 MPa 25 = 25 MPa      30 = 30 MPa      35 = 35 MPa      40 = 40 MPa	
00	<b>9 - Boost pump</b> = Without boost pump	
06	= Standard pump (5,8 cm <sup>3</sup> /n) Standard setting: 2 MPa (hydraulic /electric servo control) at 1.000 n/min	
06(xx)	= Other pressure setting on request (between 2 and 3 MPa, please contact our Technical Department)	
SA-R	<b>10 - Through drive connection for rear pump</b> = SAE-A 2 bolt female standard (ANSI B92.1a - 9T - 16/32 D.P.)	40

(continued)

**ORDER CODE** \_\_\_\_\_

**11 - Displacements of the auxiliary gear pumps group 2 (SAE-A)**

**000** = without pump

<b>204</b> = 4,2 cm <sup>3</sup> /n	<b>206</b> = 6,0 cm <sup>3</sup> /n	<b>209</b> = 8,4 cm <sup>3</sup> /n	<b>211</b> = 10,8 cm <sup>3</sup> /n
<b>214</b> = 14,4 cm <sup>3</sup> /n	<b>217</b> = 16,8 cm <sup>3</sup> /n	<b>219</b> = 19,2 cm <sup>3</sup> /n	<b>222</b> = 22,8 cm <sup>3</sup> /n
<b>226</b> = 26,2 cm <sup>3</sup> /n	<b>230</b> = 30,0 cm <sup>3</sup> /n	<b>234</b> = 34,2 cm <sup>3</sup> /n	<b>240</b> = 39,6 cm <sup>3</sup> /n

**12 - Voltage for optionals (where applicable)**

- 0** = Without
- 1** = 12V DC
- 2** = 24V DC

**13 - Optional**

- 00** = Without optional
- VS-SB** = Purge valve with screw by-pass **41**
- SB** = Screw by-pass **42**
- FLT** = Filter without clogging indicator **43**
- FLTI** = Filter with clogging indicator **44**
- MOB** = Man on board **45**
- RS** = Angle sensor **47**
- REV.S** = RPM sensor **49**
- PRS** = Pressure sensor **51**
- G/J/M/-** = Port threads and restrictor diameter

	Servo control type	Port threads	Symbol
STANDARD	SEI	Plugged	-
	SHI	1/4" BSPP	G
ON REQUEST	SHI	JIC (7/16" - 20)	J
	SHI	METRIC (M12x1,5)	M

Restrictor diameter (SHI/SEI)	
-	Without restrictor
06	Restrictor orifice ø 0,6 mm
08	Restrictor orifice ø 0,8 mm
10	Restrictor orifice ø 1,0 mm
12	Restrictor orifice ø 1,2 mm
16	Restrictor orifice ø 1,6 mm
20	Restrictor orifice ø 2,0 mm

Example G/08 = 1/4" BSPP port threads and Ø 0,8 mm restrictor (SHI)  
 Example -/08 = Ø 0,8 mm restrictor (SEI)

GENERAL DIMENSIONS / PORTS

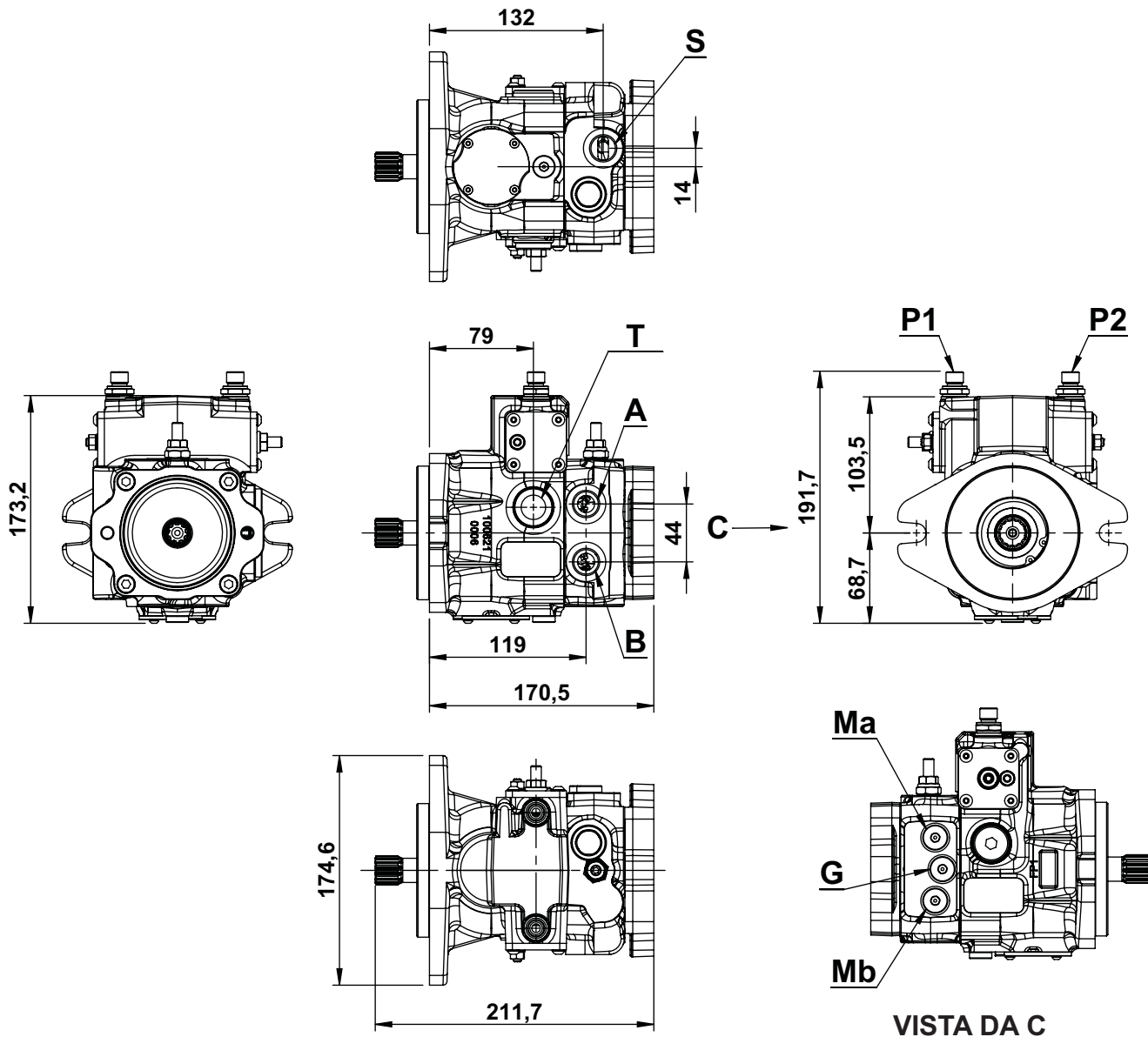

PORTS		
A - B	Main pressure ports	1/2" BSPP
T	Drain	1/2" BSPP
S	Suction	1/2" BSPP
G	Boost system pressure port	1/4" BSPP
P1 - P2	Servo control ports (male)	1/4" BSPP
Ma - Mb	Pressure gauge ports	1/4" BSPP

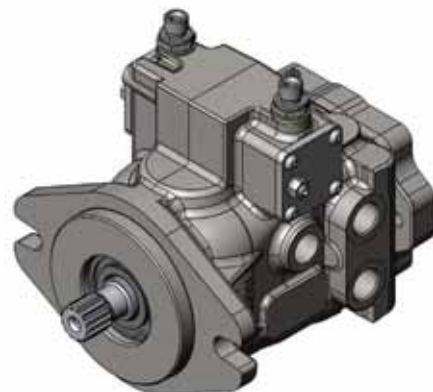

SHAFT OPTIONS AND MOUNTING FLANGES

**SS3**

**SPLINED SHAFT 13T**

Norm SAE-B ANSI B92.2-1970 CLASS 5

Max. torque = 320 Nm

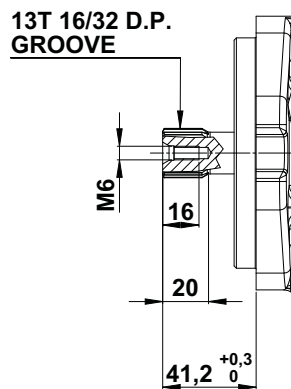

**Caution:** in case of multiple pump applications the total torque requested must be limited to the above value.

**F2**

**FLANGE SAE B - 2 BOLT**

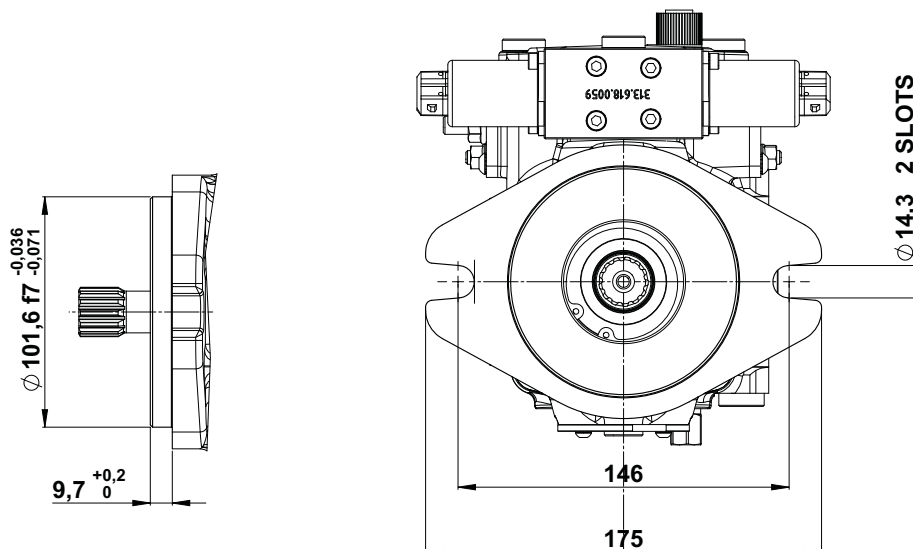

# SHI

## HYDRAULIC SERVO CONTROL

The pump displacement variation is obtained by adjusting the pressure on P1 and P2 servo control ports by means of a hydraulic proportional joystick (with integrated pressure reducing valves).

The servo control oils supply can be obtained by taking pressure from the boost pump (G port), see pag. 18.

The servo control return time can be adjusted by inserting a restrictor on the joystick supply

line (0,5 ÷ 1,2 mm).

The servo control operation curve, in both directions, goes from 0,4 to 1,8 MPa (tolerance  $\pm 5\%$ ).

The adjusting curve of the hydraulic joystick has to be a little wider (0,3 ÷ 1,9 MPa).

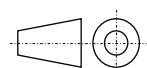
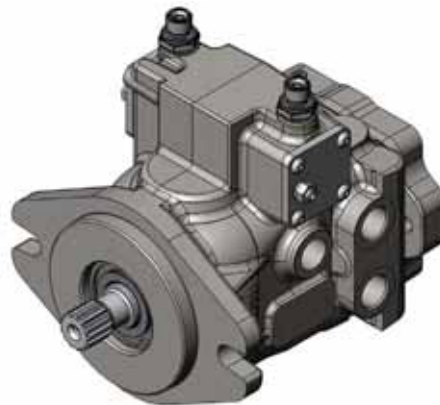
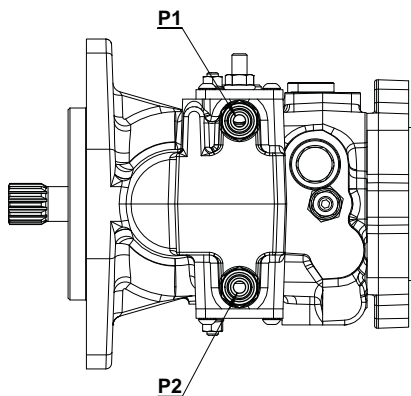
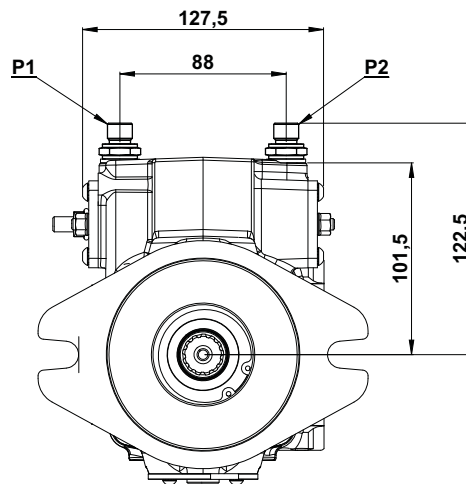
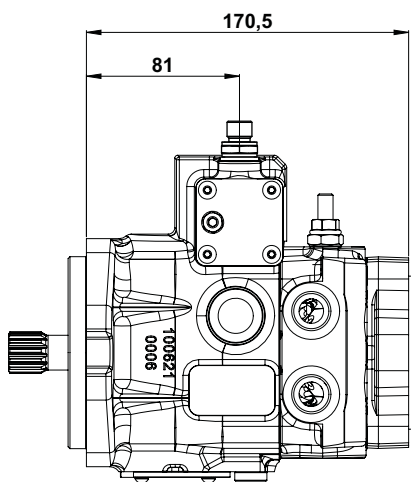

(continued)

# SHI

## COMPACT HYDRAULIC SERVO CONTROL

### HYDRAULIC DIAGRAM

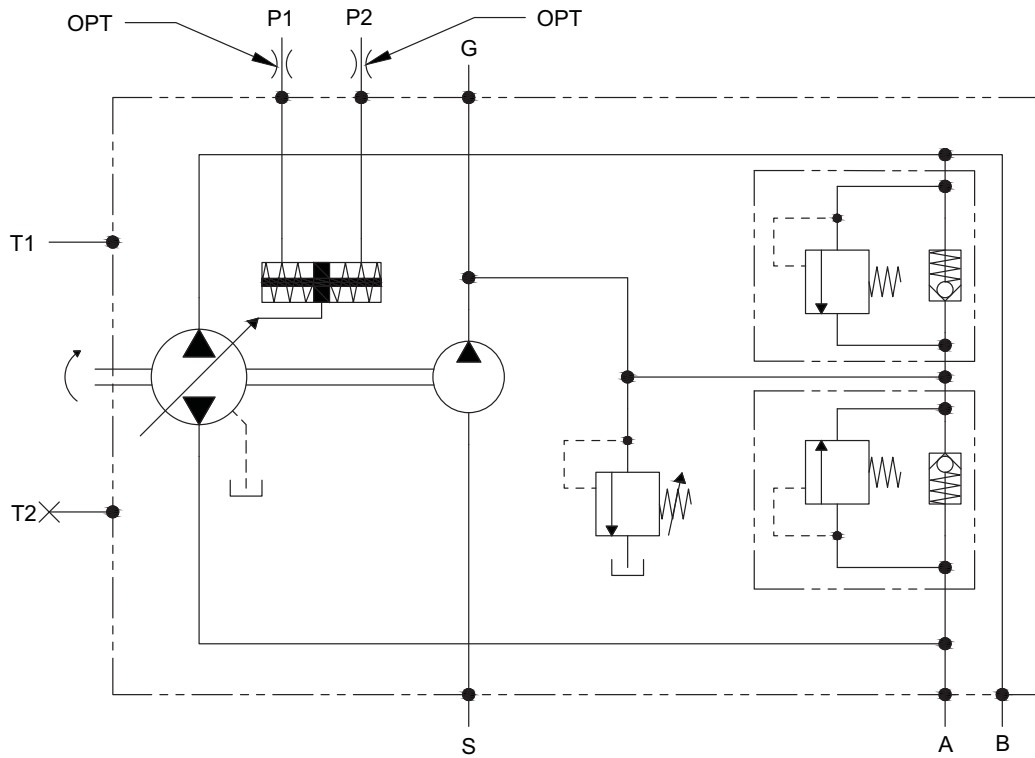

### SERVO PRESSURE - DISPLACEMENT GRAPHIC

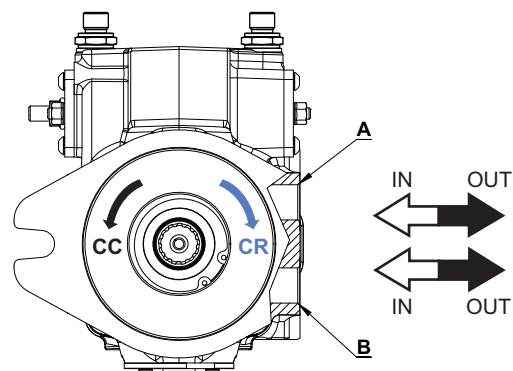
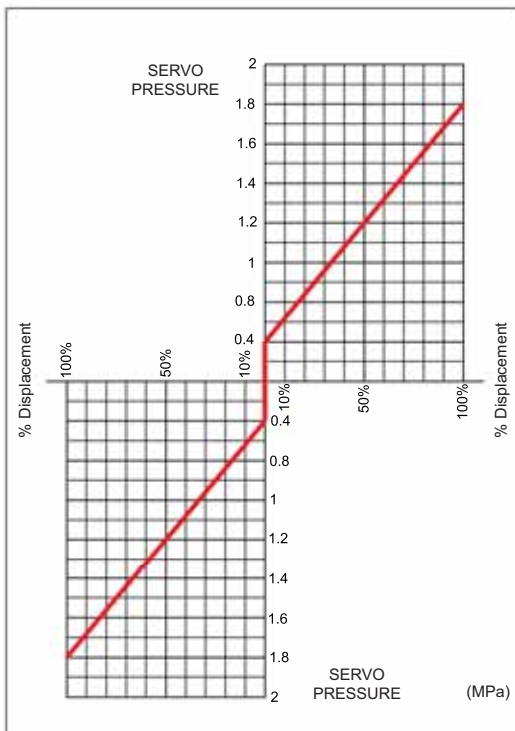

FLOW DIRECTION	PUMP		
	Port	OUT	IN
Rotation			
Clockwise (CR)	P <sub>1</sub> P <sub>2</sub>	B A	A B
Counter clockwise (CC)	P <sub>1</sub> P <sub>2</sub>	A B	B A

# SHIC

## COMPACT HYDRAULIC SERVO CONTROL

(with side pilot ports)

The pump displacement variation is obtained by adjusting the pressure on P1 and P2 servo control ports by means of a hydraulic proportional joystick (with integrated pressure reducing valves).

The servo control supply can be obtained by taking pressure from the boost pump (G port), see pag. 18.

The servo control return time can be adjusted by inserting a restrictor on the P1 and P2 ports

on the pump ( $0,5 \div 1,2$  mm).

The servo control operation curve, in both directions, goes from 0,4 to 1,8 MPa (tolerance  $\pm 5\%$ ).

The adjusting curve of the hydraulic joystick has to be a little wider ( $0,3 \div 1,9$  MPa).

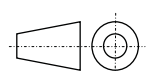
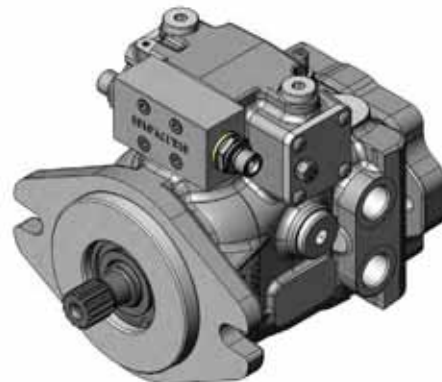
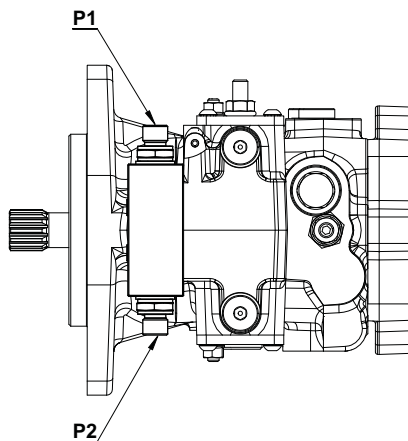
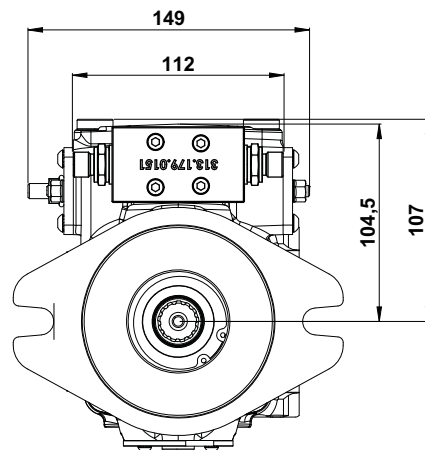
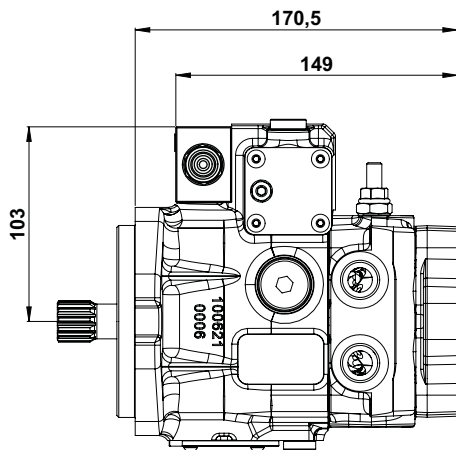



(continued)

# SHIC

## COMPACT HYDRAULIC SERVO CONTROL

(with side pilot ports)

### HYDRAULIC DIAGRAM

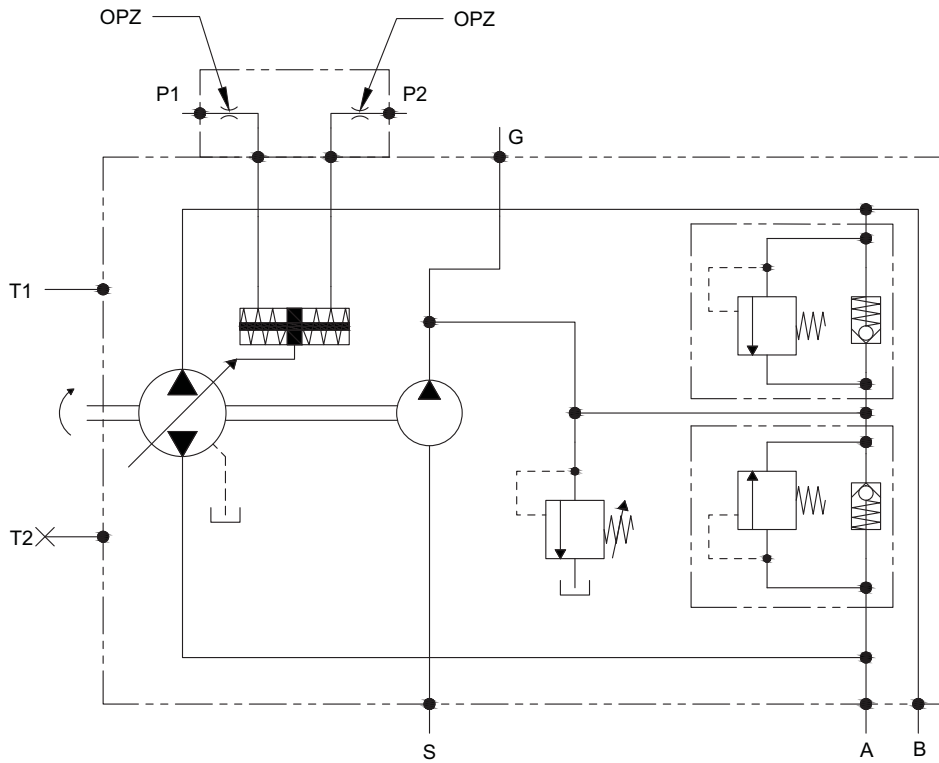

SERVO PRESSURE - DISPLACEMENT GRAPHIC

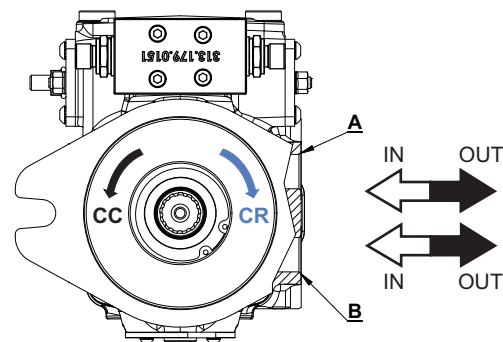
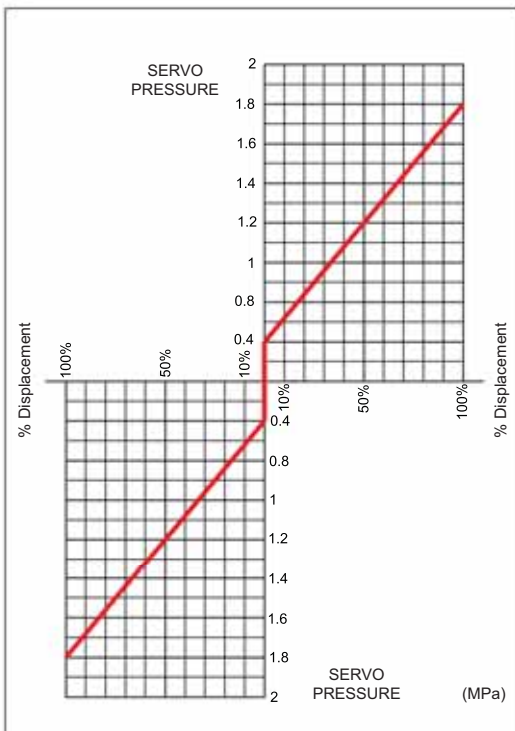

FLOW DIRECTION	PUMP		
	Port	OUT	IN
Rotation			
Clockwise (CR)	P <sub>1</sub> P <sub>2</sub>	B A	A B
Counter clockwise (CC)	P <sub>1</sub> P <sub>2</sub>	A B	B A

**SEI 1.3** (12V DC)

**SEI 2.3** (24V DC)

**ELECTRO-PROPORTIONAL SERVO CONTROL**

(AMP junior timer connector)

The pump displacement variation is obtained by an electric signal that goes from:

- 0 to 750 mA (24V DC voltage)
- 0 to 1500 mA (12V DC voltage)

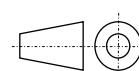
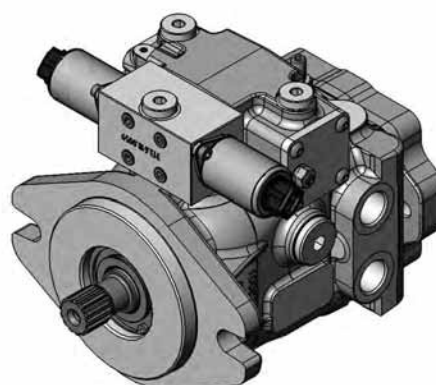
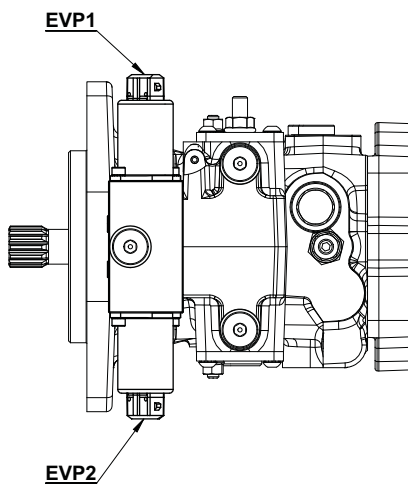
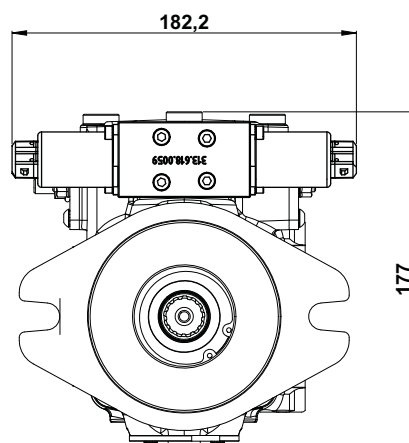
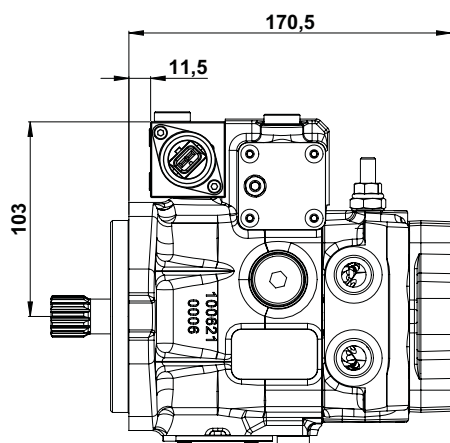

(continued)

**SEI 1.3** (12V DC)

**SEI 2.3** (24V DC)

**ELECTRO-PROPORTIONAL SERVO CONTROL**

(AMP junior timer connector)

HYDRAULIC DIAGRAM

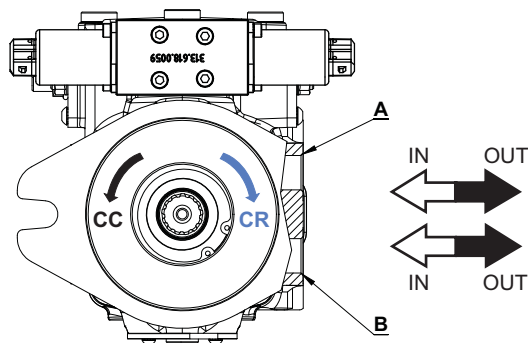
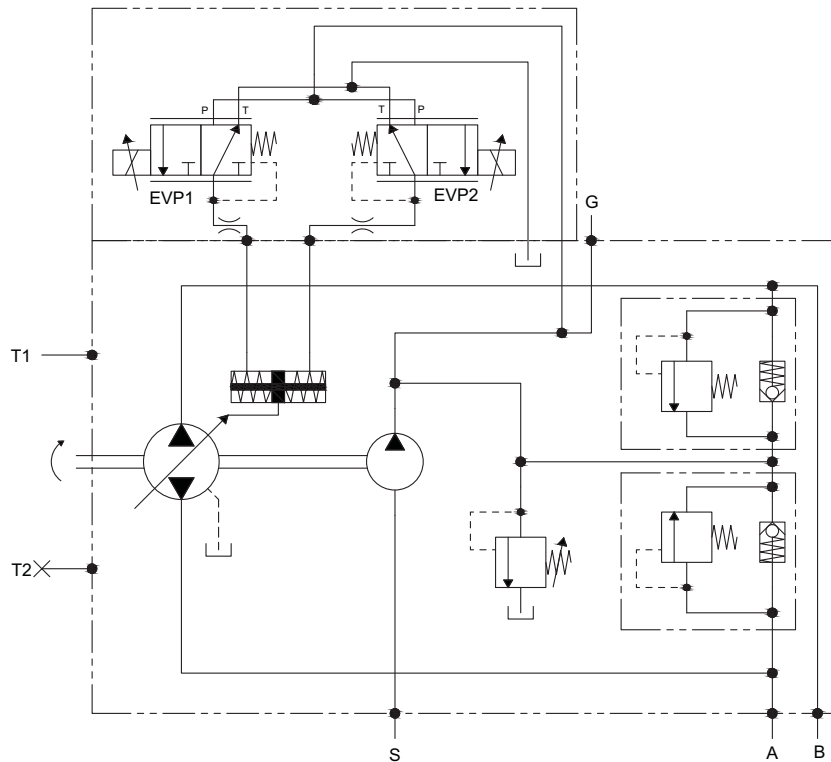

FLOW DIRECTION		PUMP	
Rotation	EVP	OUT	IN
Clockwise (CR)	EVP1 EVP2	B A	A B
Counter clockwise (CC)	EVP1 EVP2	A B	B A

(continued)

**SEI 1.3** (12V DC)

**SEI 2.3** (24V DC)

**ELECTRO-PROPORTIONAL SERVO CONTROL**

(AMP junior timer connector)

(CURRENT-DISPLACEMENT GRAPHIC)

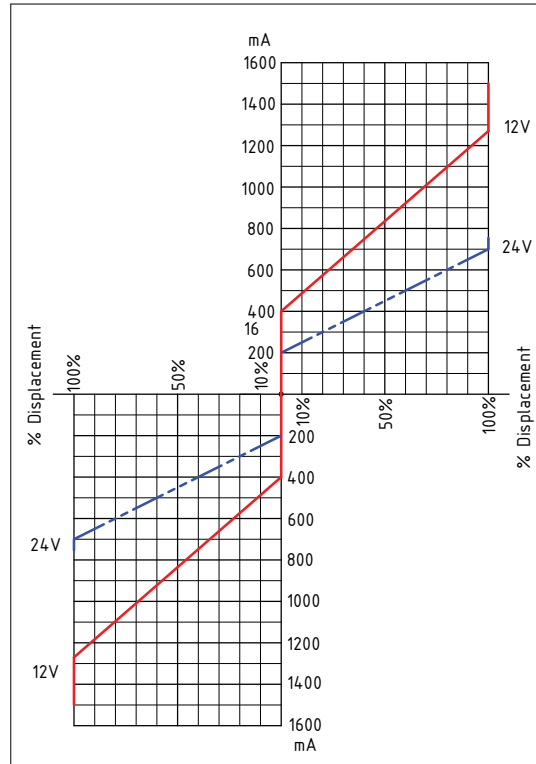

ELECTRICAL FEATURES		
Voltage	12 V DC	24 V DC
Electric current	1500 mA	750 mA
Load resistance	4,72 Ω ± 5%	20,8 Ω ± 5%
Type of control	Current control	
	PWM 100 Hz (suggested)	
Type of connection	AMP Junior Timer	
Protection class	Until IP6K6 / IPX9K	

HYDRAULIC FEATURES	
Max. pressure (P, T)	pP= 5 MPa, pT= 3 MPa
Hysteresis (w/PWM)	<0,07 MPa (pA=2,0)
	<0,1 MPa (pA=2,5)
	<0,15 MPa (pA=3,5)
Filtration ratio	125 μm
Oil contamination level	Min. filtration ratio: 20/18/15
	According ISO 4406
	Hydraulic oil DIN 51524
Min./max. oil temperature	From -20 to +90°C

**SEI 1.3D** (12V DC)

**SEI 2.3D** (24V DC)

**ELECTRO-PROPORTIONAL SERVO CONTROL**

(Deutsch connector)

The pump displacement variation is obtained by an electric signal that goes from:

- 0 to 750 mA (24V DC voltage)
- 0 to 1500 mA (12V DC voltage)

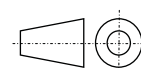
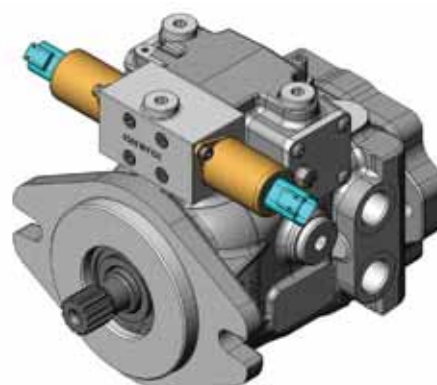
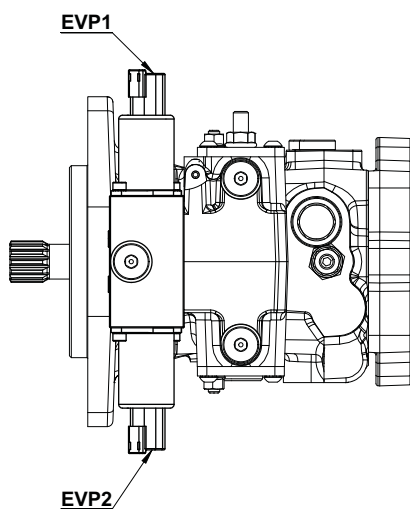
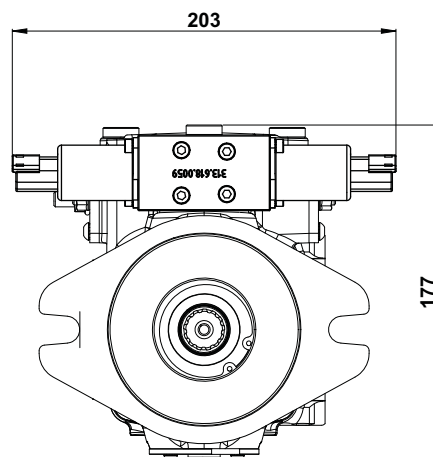
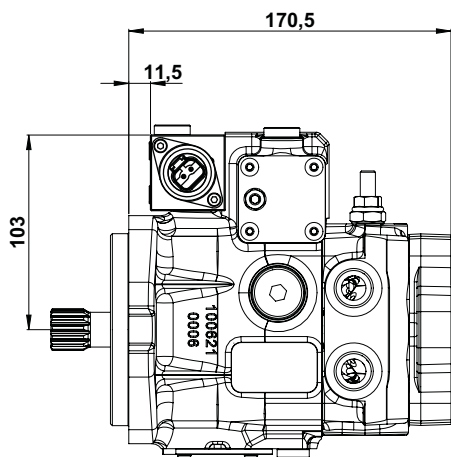

(continued)

**SEI 1.3D** (12V DC)

**SEI 2.3D** (24V DC)

**ELECTRO-PROPORTIONAL SERVO CONTROL**

(Deutsch connector)

**HYDRAULIC DIAGRAM**

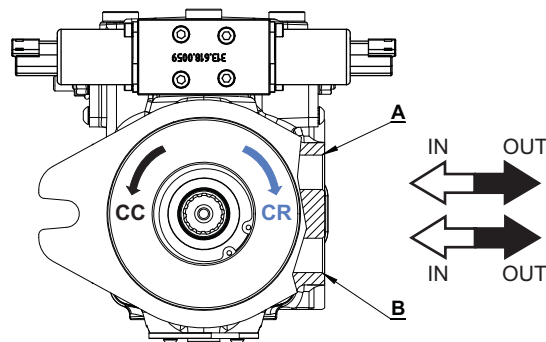
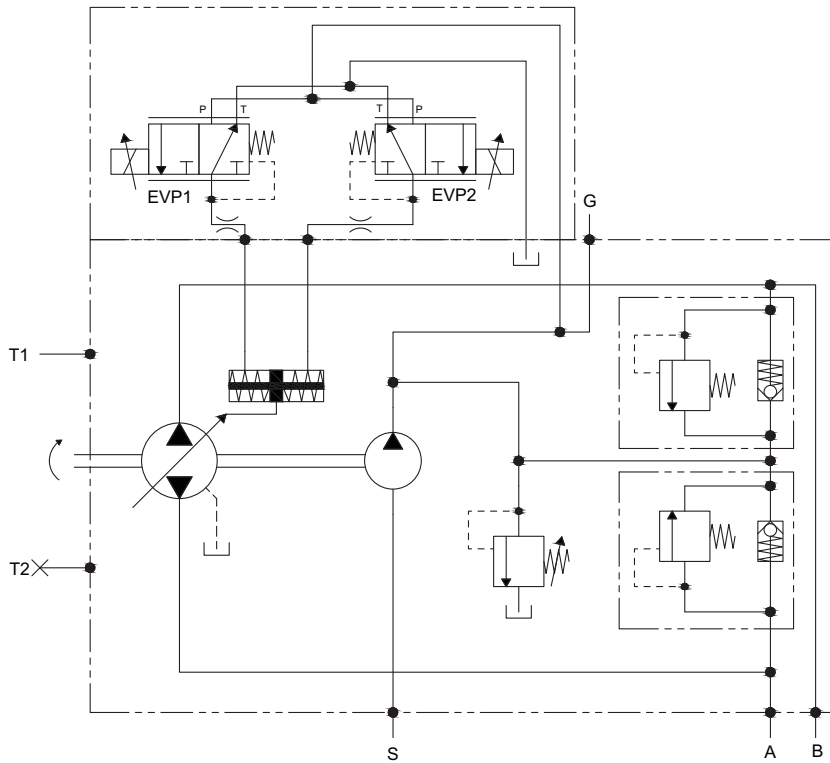

FLOW DIRECTION	PUMP		
Rotation	 EVP	OUT	IN
Clockwise (CR)	EVP1 EVP2	B A	A B
Counter clockwise (CC)	EVP1 EVP2	A B	B A

(continued)

**SEI 1.3D** (12V DC)

**SEI 2.3D** (24V DC)

**ELECTRO-PROPORTIONAL SERVO CONTROL**

(Deutsch connector)

CURRENT-DISPLACEMENT GRAPHIC

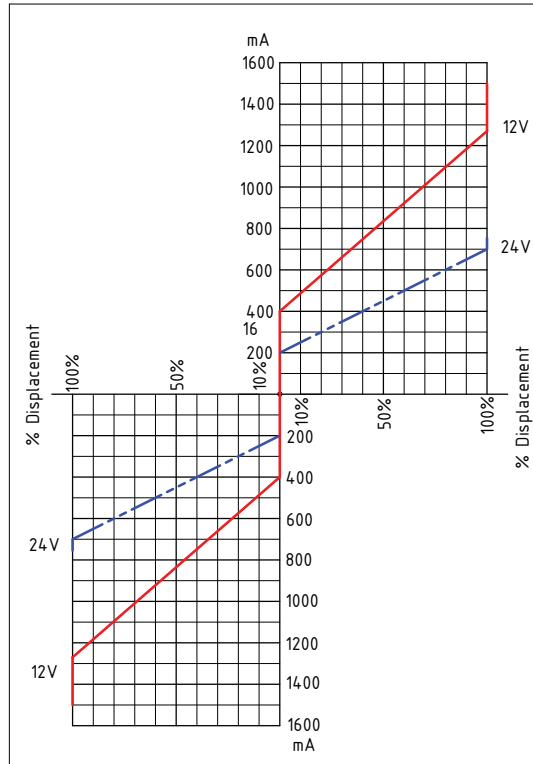

ELECTRICAL FEATURES		
Voltage	12 V DC	24 V DC
Electric current	1500 mA	750 mA
Load resistance	4,72 Ω ± 5%	20,8 Ω ± 5%
Type of control	Current control	
	PWM 100 Hz (suggested)	
Type of connection	DEUTSCH DT 04-2P	
Protection class	Until IP6K6 / IPX9K	

HYDRAULIC FEATURES	
Max. pressure (P, T)	pP= 5 MPa, pT= 3 MPa
Hysteresis (w/PWM)	<0,07 MPa (pA=2,0)
	<0,1 MPa (pA=2,5)
	<0,15 MPa (pA=3,5)
Filtration ratio	125 µm
Oil contamination level	Min. filtration ratio: 20/18/15
	According ISO 4406
	Hydraulic oil DIN 51524
Min./max. oil temperature	From -20 to +90°C

# SHIX

## HYDRAULIC SERVO CONTROL WITH FEED BACK

The pump displacement variation is obtained by adjusting the pressure on P1 and P2 servo control ports by means of a hydraulic proportional joystick (with integrated pressure reducing valves).

The servo control supply can be obtained by taking pressure from the boost pump (G port), see pag. 18.

The servo control return time can be adjusted by inserting a restrictor on the joystick supply line (0,5 ÷ 1,2 mm).

The servo control operation curve, in both directions, goes from 0,4 to 1,8 MPa (tolerance  $\pm 5\%$ ).

The adjusting curve of the hydraulic joystick has to be a little higher (0,3 ÷ 1,9 MPa).

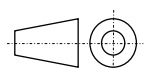
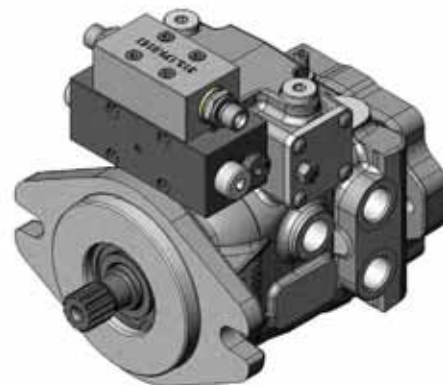
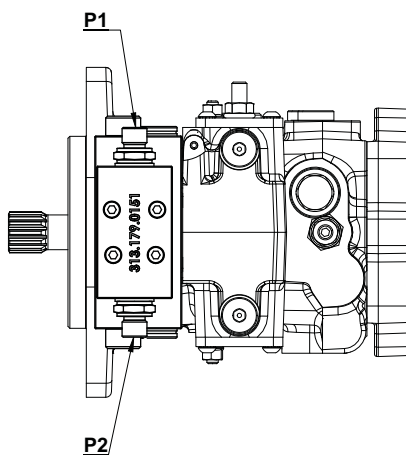
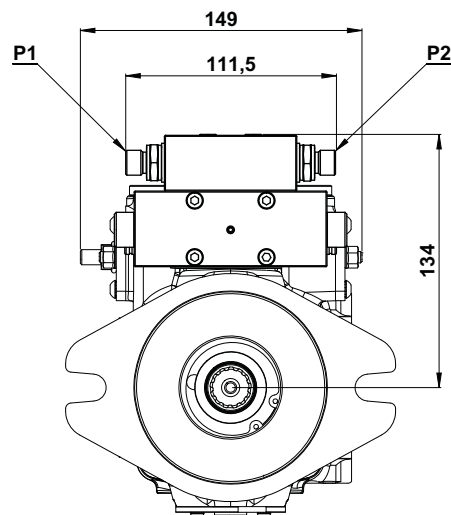
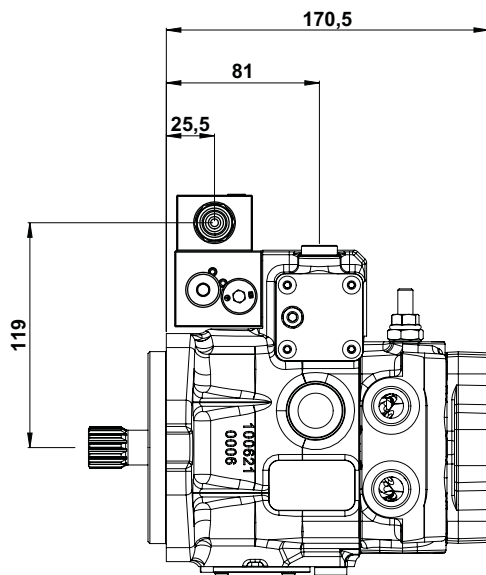



(continued)

# SHIX

## HYDRAULIC SERVO CONTROL WITH FEED BACK

### HYDRAULIC DIAGRAM

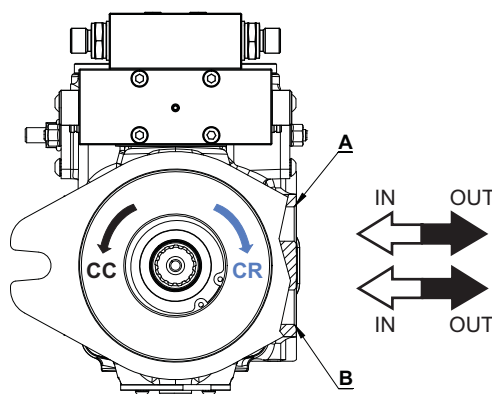
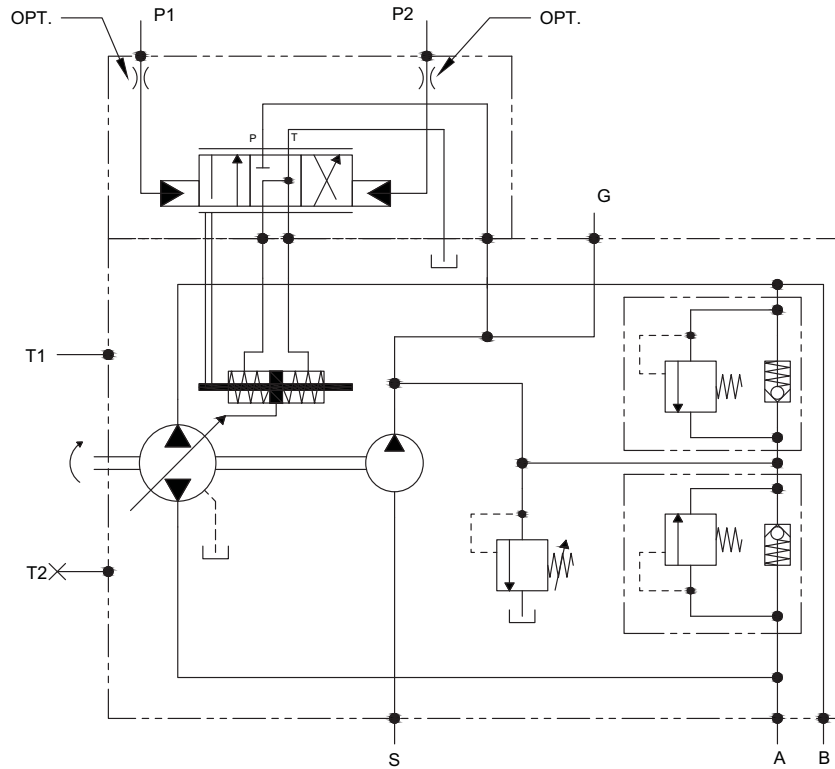

FLOW DIRECTION	PUMP		
	Port	OUT	IN
Rotation			
Clockwise (CR)	P <sub>1</sub>	B	A
	P <sub>2</sub>	A	B
Counter clockwise (CC)	P <sub>1</sub>	A	B
	P <sub>2</sub>	B	A

# SMIX

## MANUAL LEVER CONTROL WITH FEED BACK

The pump displacement variation is directly related to the angle position of the lever.

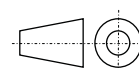
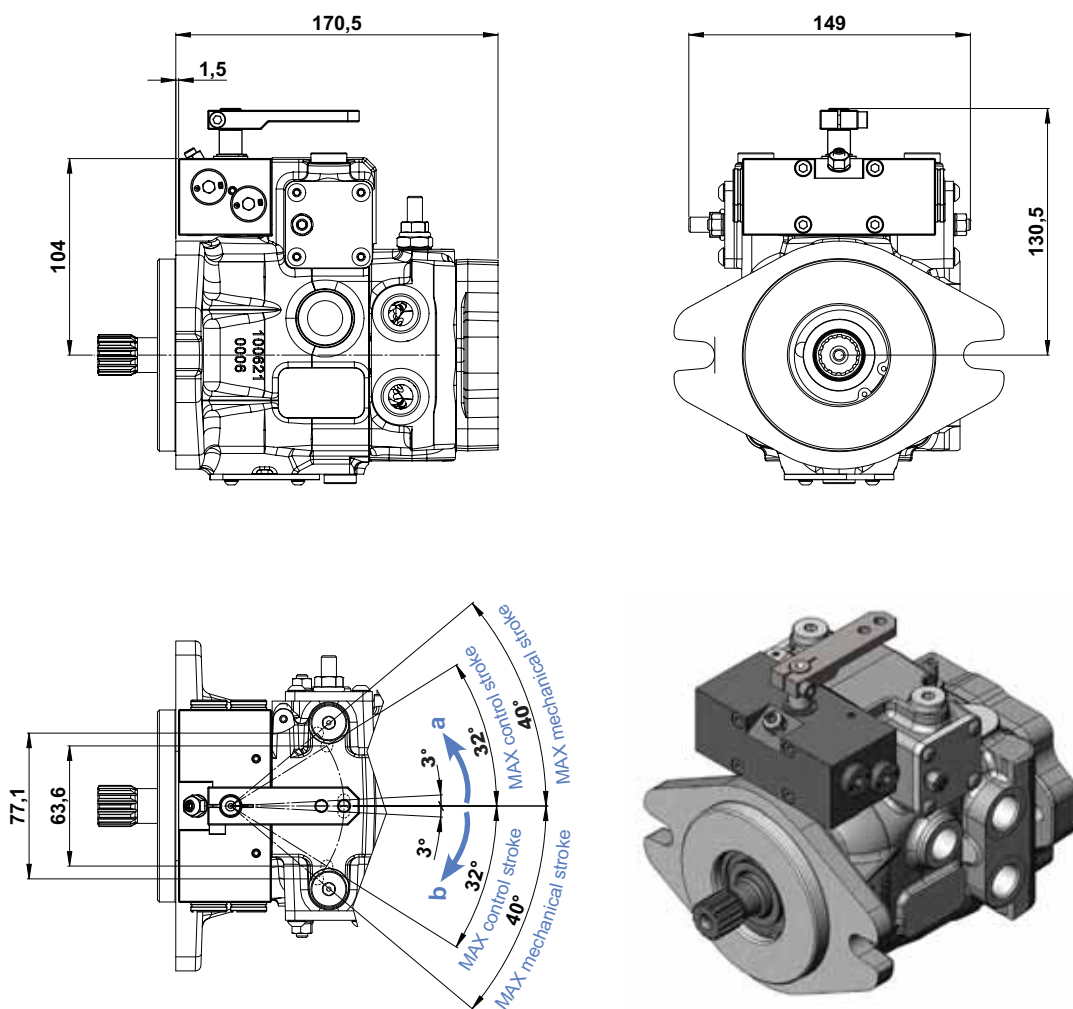

(continued)

# SMIX

## MANUAL LEVER CONTROL WITH FEED BACK

### HYDRAULIC DIAGRAM

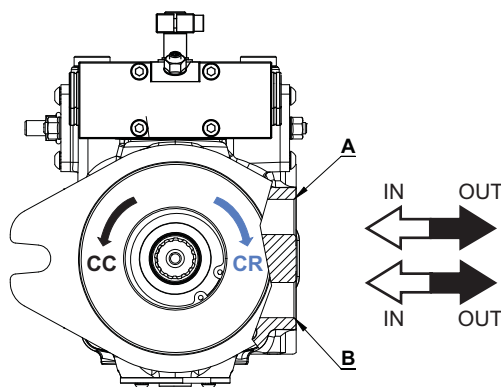
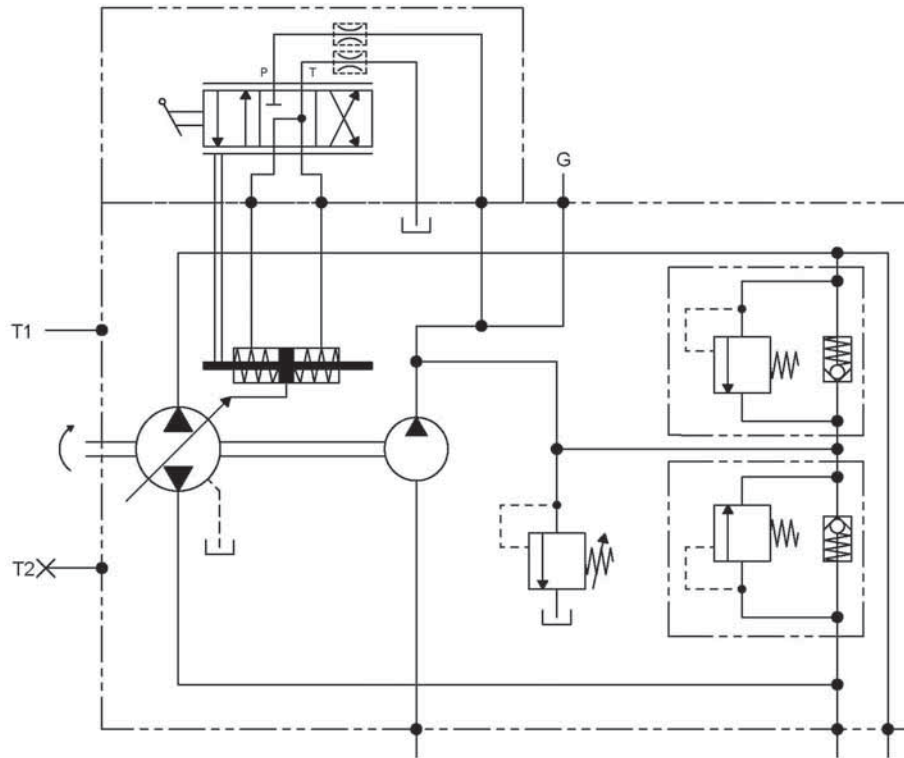

FLOW DIRECTION	PUMP		
	Port	OUT	IN
Rotation			
Clockwise (CR)	a	B	A
	b	A	B
Counter clockwise (CC)	a	A	B
	b	B	A

**SEIX 1.3** (12V DC)

**SEIX 2.3** (24V DC)

**ELECTRO-PROPORTIONAL SERVO CONTROL WITH FEED BACK**

(AMP junior timer connector)

The pump displacement variation is obtained by an electric signal that goes from:

- 0 to 750 mA (24V DC voltage)
- 0 to 1500 mA (12V DC voltage)

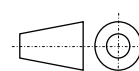
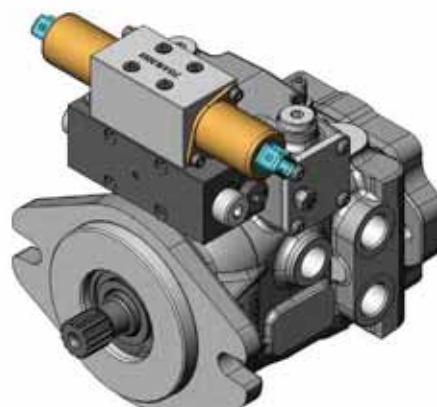
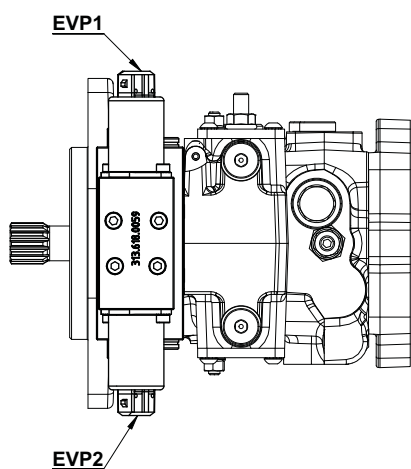
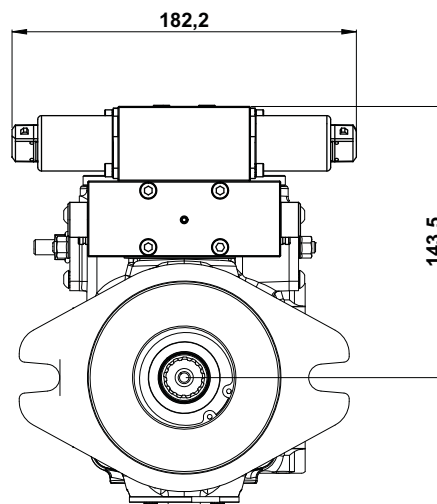
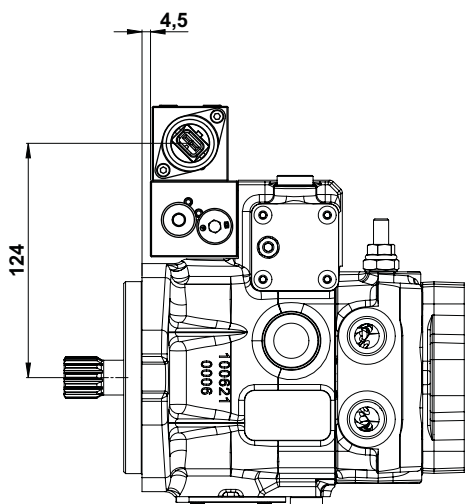

(continued)

**SEIX 1.3** (12V DC)

**SEIX 2.3** (24V DC)

**ELECTRO-PROPORTIONAL SERVO CONTROL WITH FEED BACK**

(AMP junior timer connector)

HYDRAULIC DIAGRAM

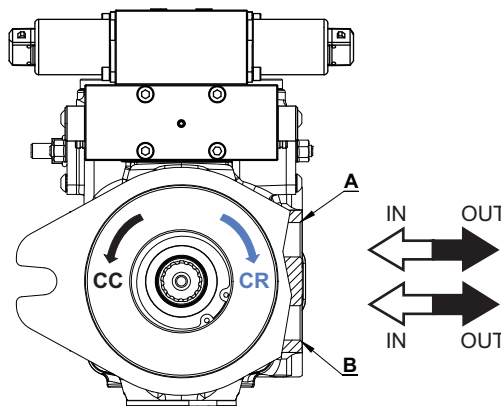
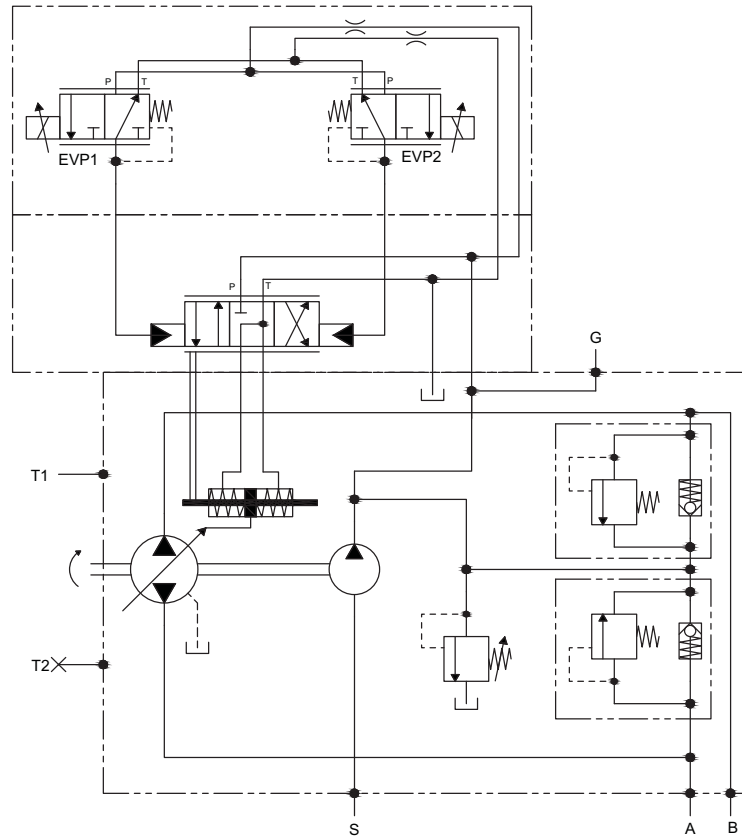

FLOW DIRECTION		PUMP	
Rotation	EVP	OUT	IN
Clockwise (CR)	EVP1 EVP2	B A	A B
Counter clockwise (CC)	EVP1 EVP2	A B	B A

(continued)

**SEIX 1.3** (12V DC)

**SEIX 2.3** (24V DC)

**ELECTRO-PROPORTIONAL SERVO CONTROL WITH FEED BACK**

(AMP junior timer connector)

CURRENT-DISPLACEMENT GRAPHIC

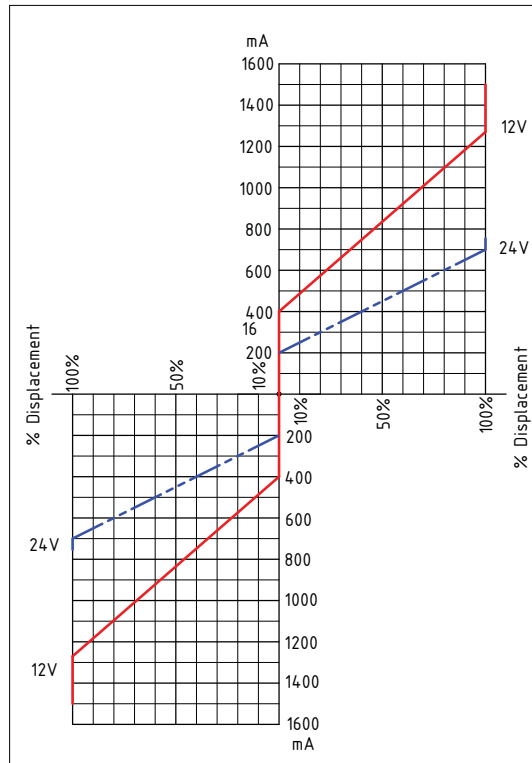

ELECTRICAL FEATURES		
Voltage	12 V DC	24 V DC
Electric current	1500 mA	750 mA
Load resistance	4,72 Ω ± 5%	20,8 Ω ± 5%
Type of control	Current control	
	PWM 100 Hz (suggested)	
Type of connection	AMP Junior Timer	
Protection class	Until IP6K6 / IPX9K	

HYDRAULIC FEATURES	
Max. pressure (P, T)	pP= 5 MPa, pT= 3 MPa
Hysteresis (w/PWM)	<0,07 MPa (pA=2,0)
	<0,1 MPa (pA=2,5)
	<0,15 MPa (pA=3,5)
Filtration ratio	125 μm
Oil contamination level	Min. filtration ratio: 20/18/15
	According ISO 4406
	Hydraulic oil DIN 51524
Min./max. oil temperature	From -20 to +90°C

**SEIX 1.3D** (12V DC)  
**SEIX 2.3D** (24V DC)

**ELECTRO-PROPORTIONAL SERVO CONTROL WITH FEED BACK**

(Deutsch connector)

The pump displacement variation is obtained by an electric signal that goes from:

- 0 to 750 mA (24V DC voltage)
- 0 to 1500 mA (12V DC voltage)

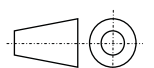
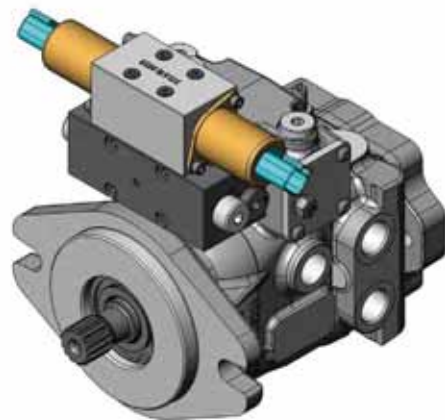
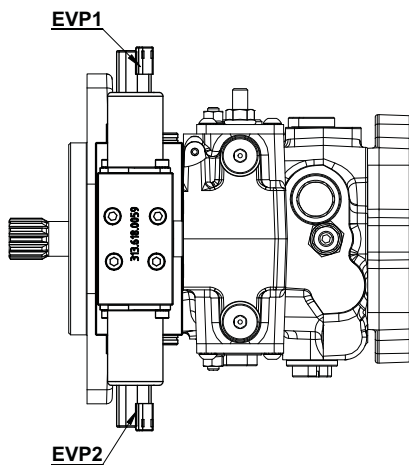
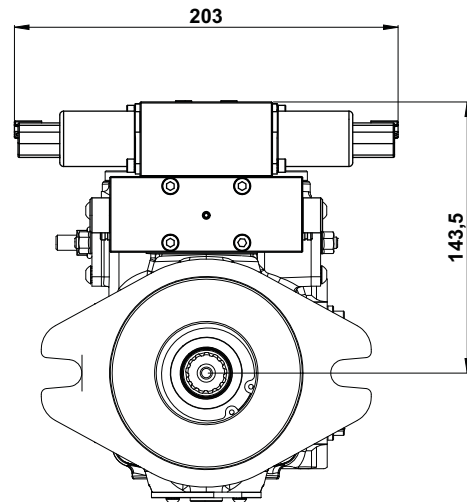
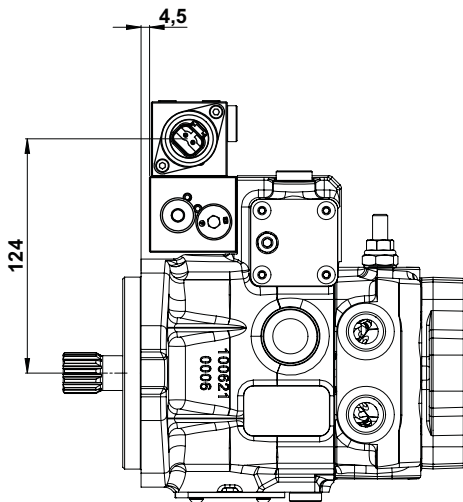

(continued)

**SEIX 1.3D** (12V DC)  
**SEIX 2.3D** (24V DC)

**ELECTRO-PROPORTIONAL SERVO CONTROL WITH FEED BACK**

(Deutsch connector)

**HYDRAULIC DIAGRAM**

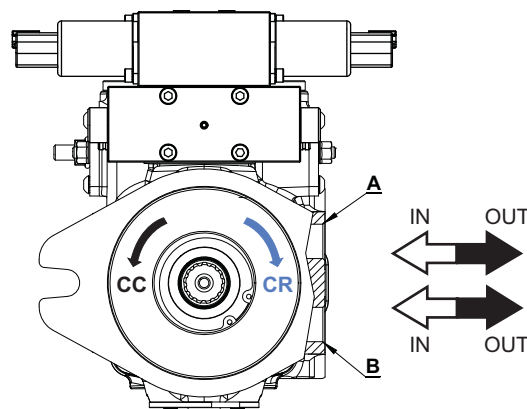
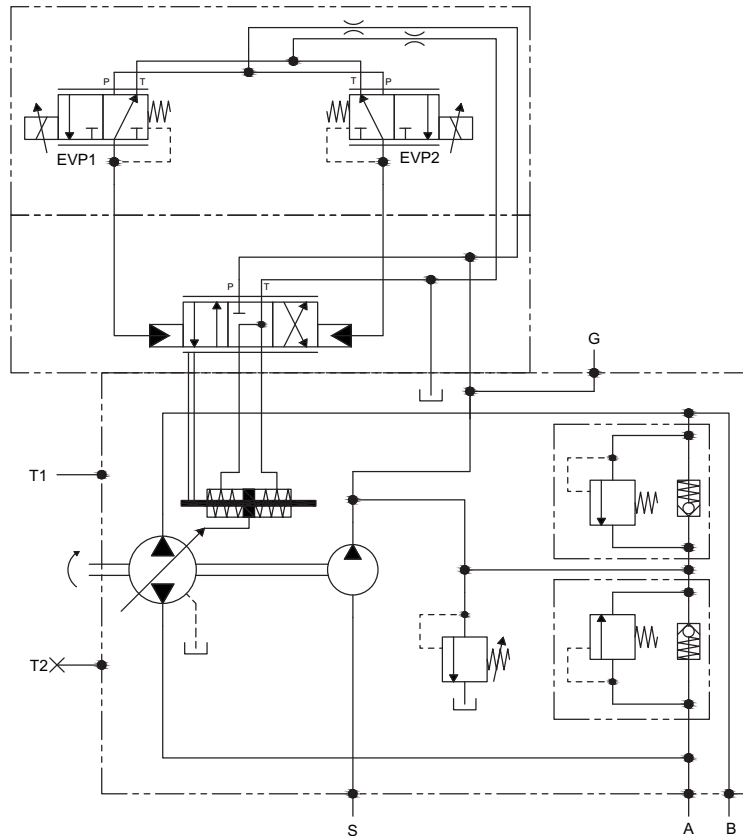

FLOW DIRECTION	PUMP		
Rotation	EVP	OUT	IN
Clockwise (CR)	EVP1 EVP2	B A	A B
Counter clockwise (CC)	EVP1 EVP2	A B	B A



(continued)

**SEIX 1.3D** (12V DC)  
**SEIX 2.3D** (24V DC)

**ELECTRO-PROPORTIONAL SERVO CONTROL WITH FEED BACK**

(Deutsch connector)

CURRENT-DISPLACEMENT GRAPHIC

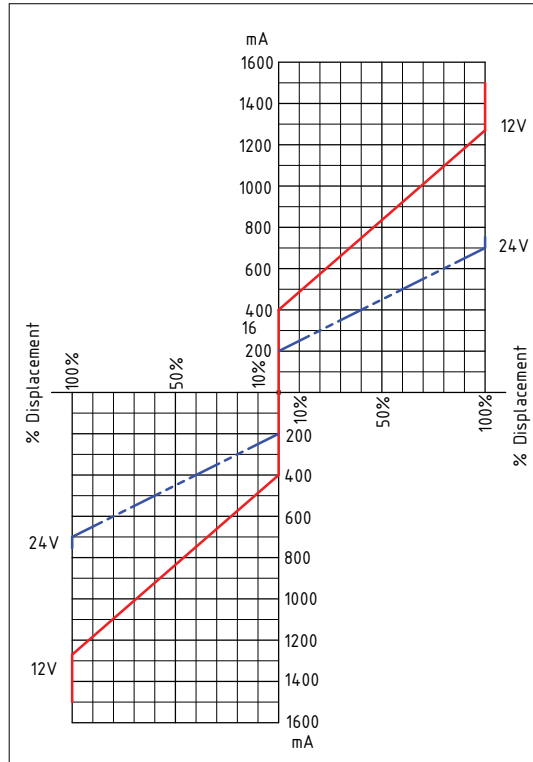

ELECTRICAL FEATURES		
Voltage	12 V DC	24 V DC
Electric current	1500 mA	750 mA
Load resistance	4,72 Ω ± 5%	20,8 Ω ± 5%
Type of control	Current control	
	PWM 100 Hz (suggested)	
Type of connection	DEUTSCH DT 04-2P	
Protection class	Until IP6K6 / IPX9K	

HYDRAULIC FEATURES	
Max. pressure (P, T)	pP= 5 MPa, pT= 3 MPa
Hysteresis (w/PWM)	<0,07 MPa (pA=2,0)
	<0,1 MPa (pA=2,5)
	<0,15 MPa (pA=3,5)
Filtration ratio	125 µm
Oil contamination level	Min. filtration ratio: 20/18/15
	According ISO 4406
	Hydraulic oil DIN 51524
Min./max. oil temperature	From -20 to +90°C

THROUGH DRIVE OPTION

**SAE A - R**

FLANGE SAE A - 2 BOLT

ISO 3019-7

Max. torque = 120 Nm

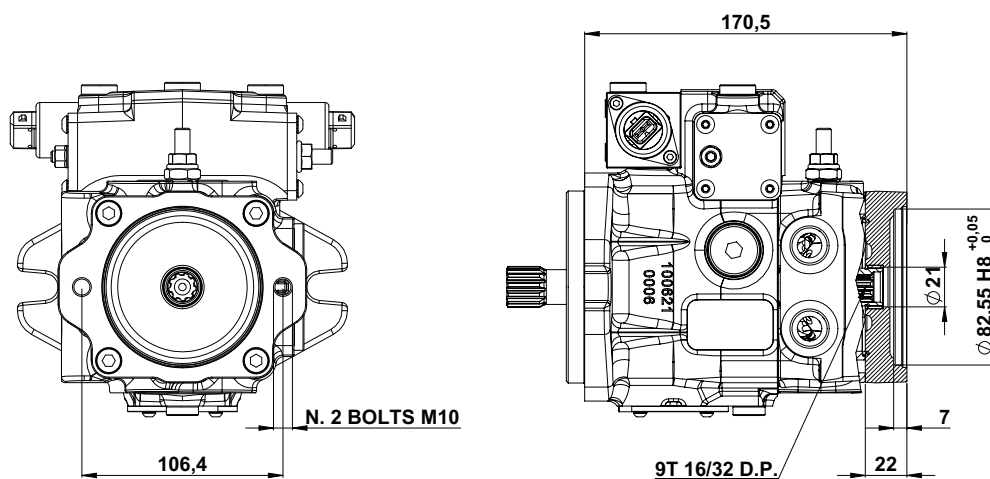

ANSI B92.1-1970 CLASS 7

# OPTIONAL VS-SB

## PURGE VALVE WITH SCREW BY-PASS

For the pump TPV-TPVTC 1500 an integrated purge valve (loop flushing) is available.

The valve consists of a spring centered shuttle spool connecting automatically the low pressure line (boost) with the reservoir removing heat from the system.

The quantity of the flushing oil is a function of the low system pressure (boost) and the size of the orifice on the valve (different orifices are available referred to the system pressure). The spool shifts at a differential pressure of about 0,8 MPa (116 PSI).

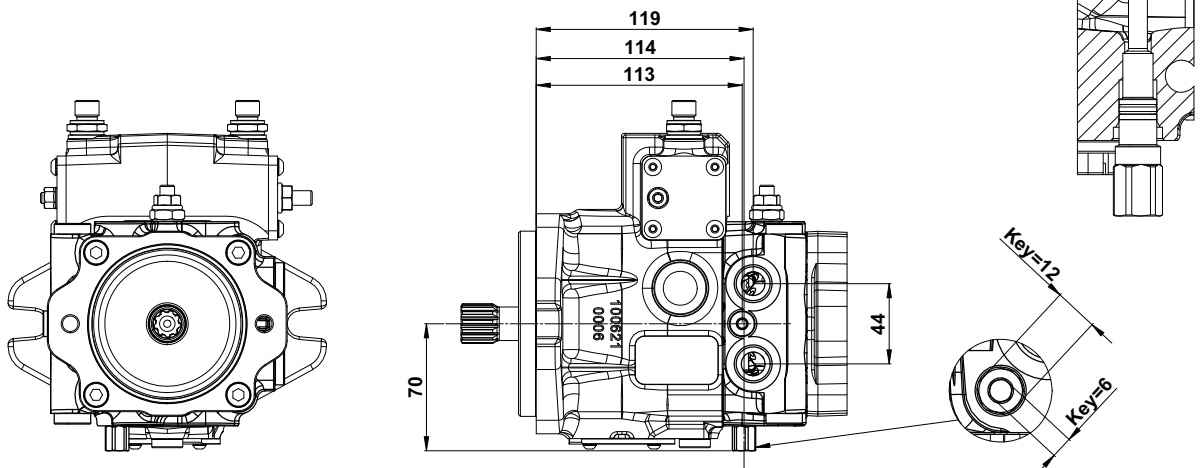
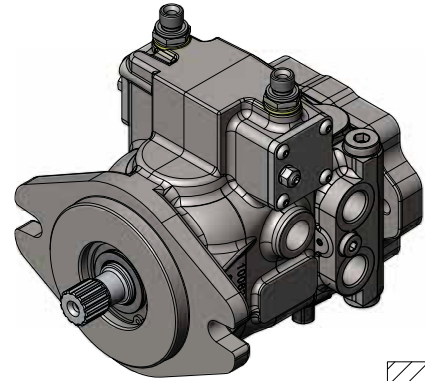

HYDRAULIC DIAGRAM

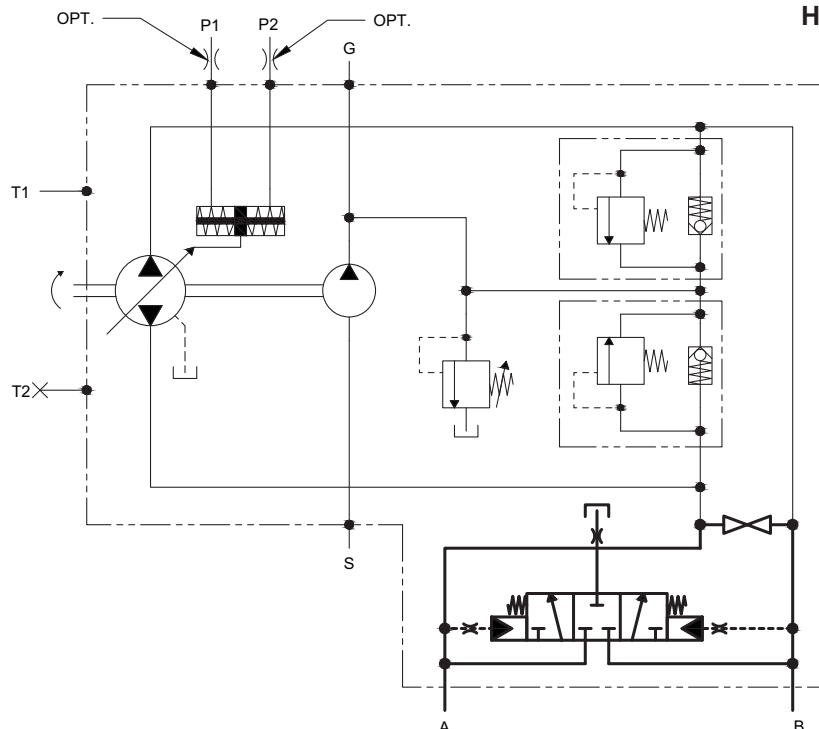

# OPTIONAL SB

## SCREW BY-PASS

To by pass the oil flow from one direction to the other, with the pump not running or in emergency condition, a by pass screw can be actuated to connect the 2 lines of the hydraulic system. The orifice is completely open after 4 counter-clockwise rotations of the screw.

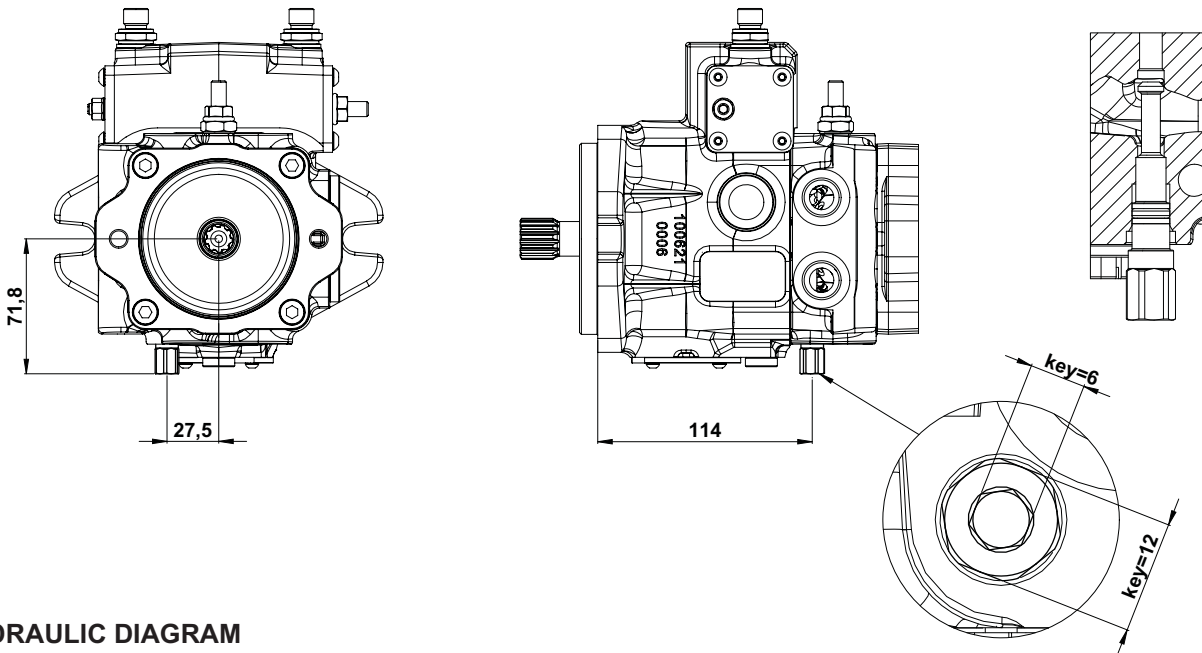

### HYDRAULIC DIAGRAM

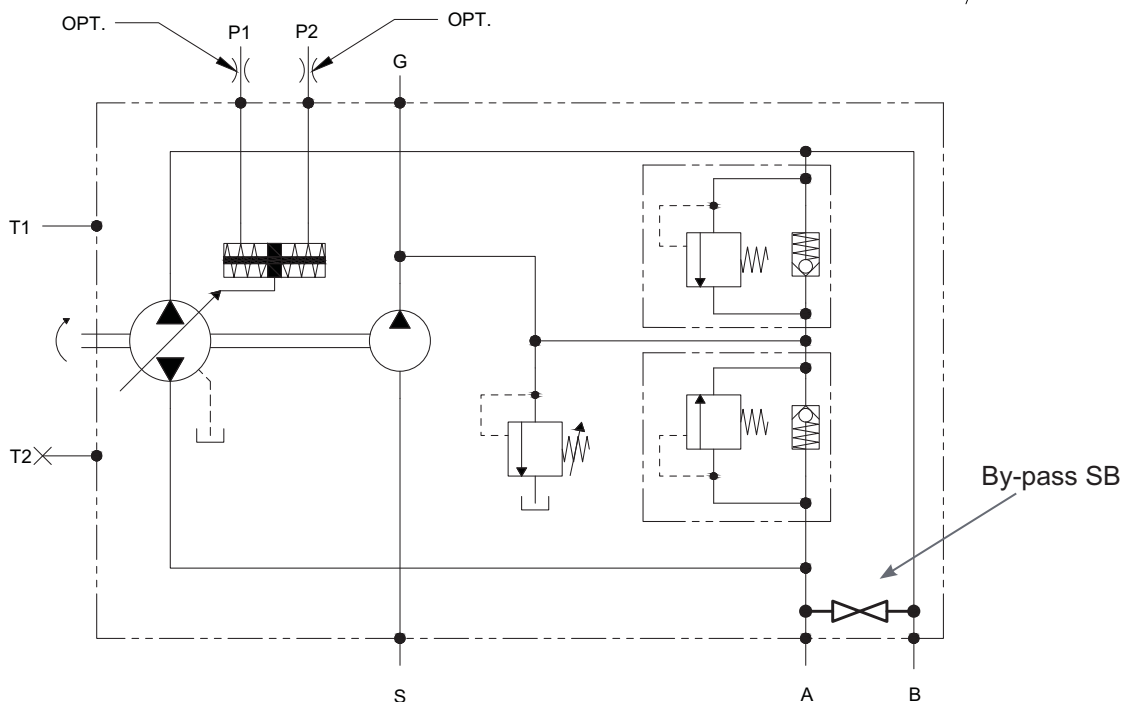

# OPTIONAL FLT

## FILTER WITHOUT CLOGGING INDICATOR

To assure the oil filtration of the boost pump a filter is available, directly flanged to the pump suction line.

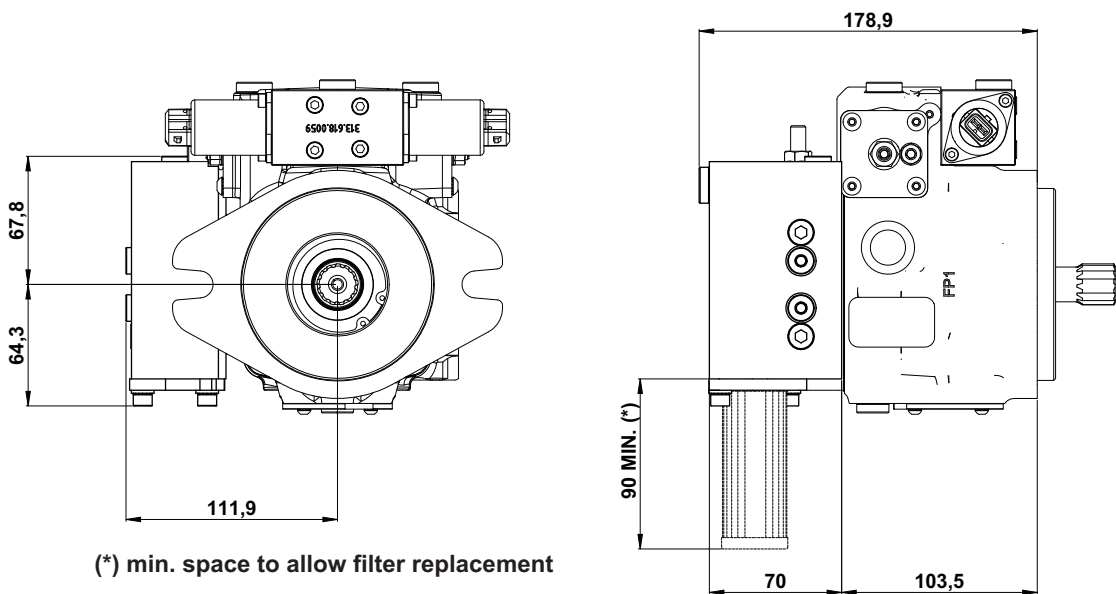
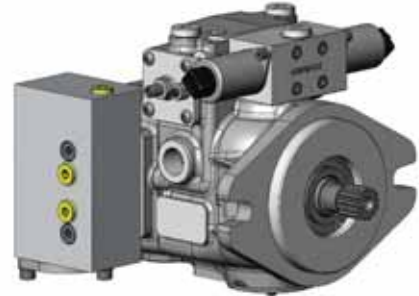

### HYDRAULIC DIAGRAM

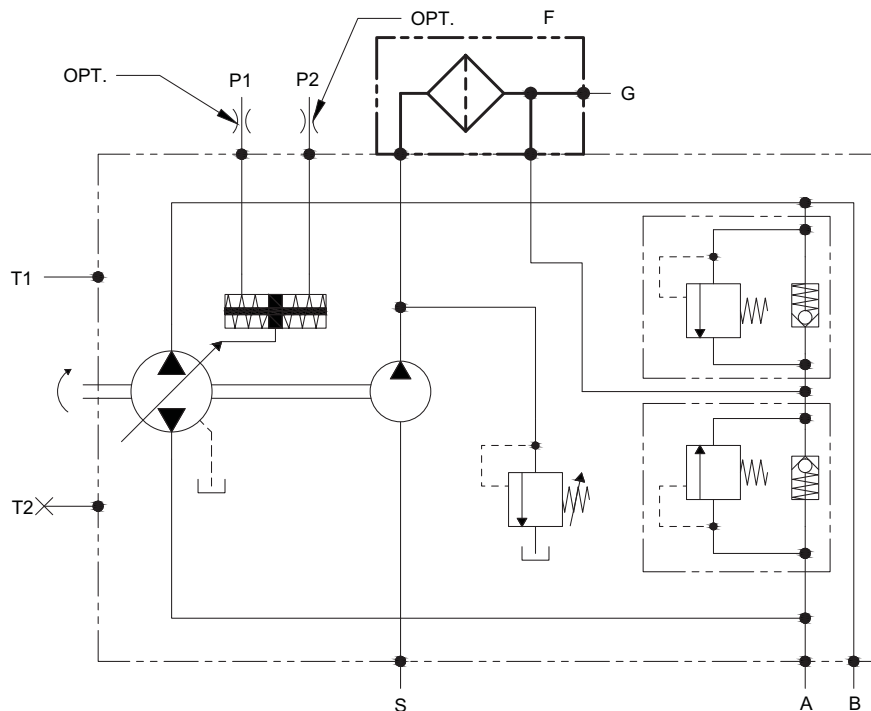

# OPTIONAL FLTI

## FILTER WITH CLOGGING INDICATOR

To assure the oil filtration of the boost pump a filter, with clogging indicator, is available directly flanged to the pump suction line. The clogging indicator is set at 0,13 MPa.

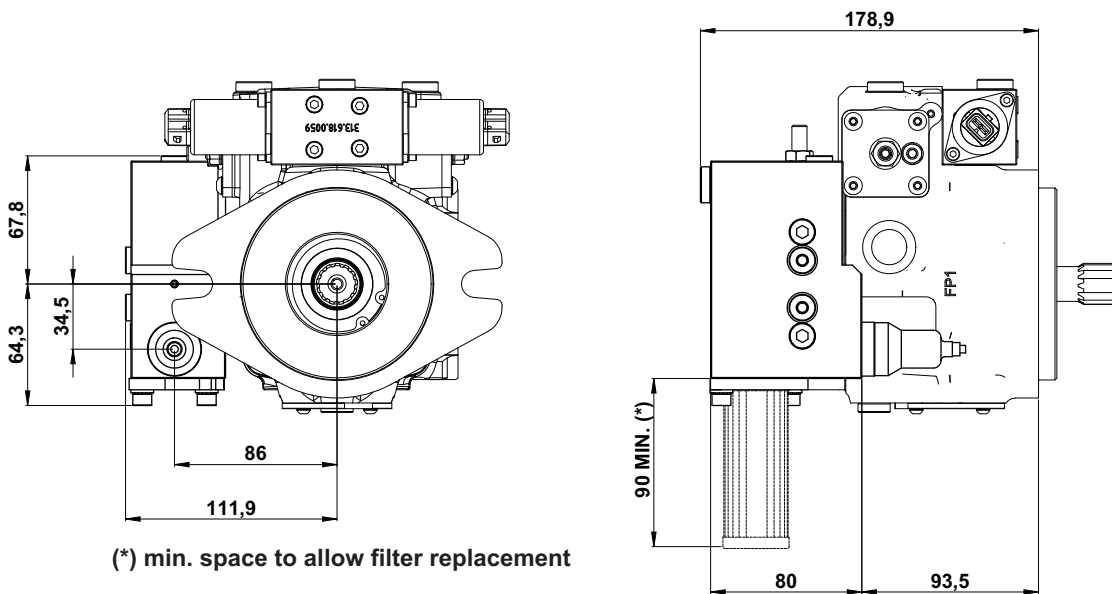
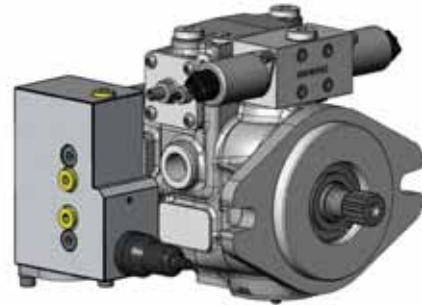

### HYDRAULIC DIAGRAM

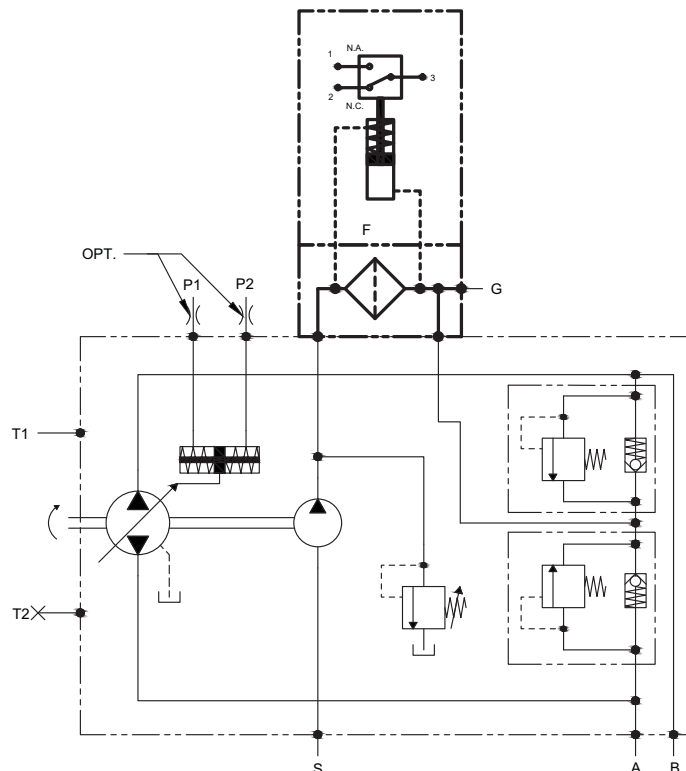

# OPTIONAL MOB

## MAN ON BOARD

A normally open solenoid valve cuts the oil flow when not activated.

The valve allows oil flow to feed the hydraulic system only if activated (the operator is seated).

The solenoid valve is available for 12V or 24V DC voltage.

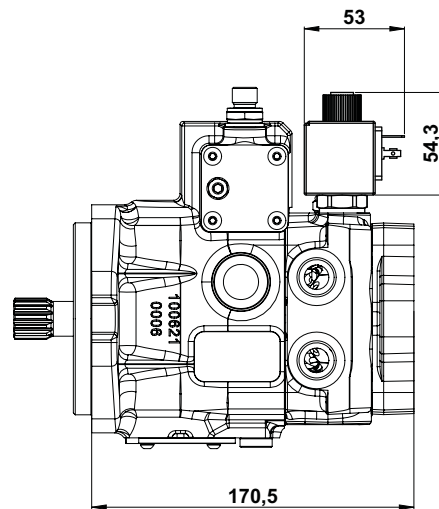
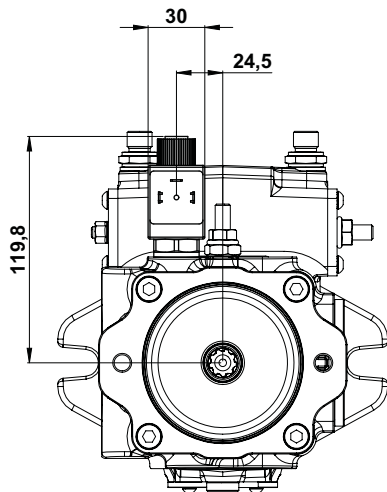
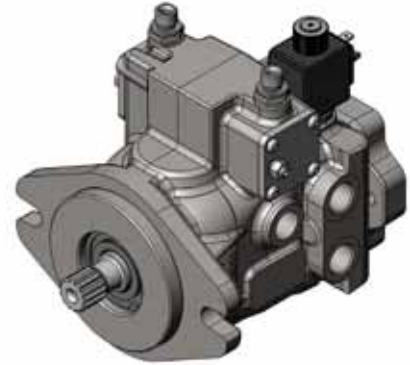

### HYDRAULIC DIAGRAM

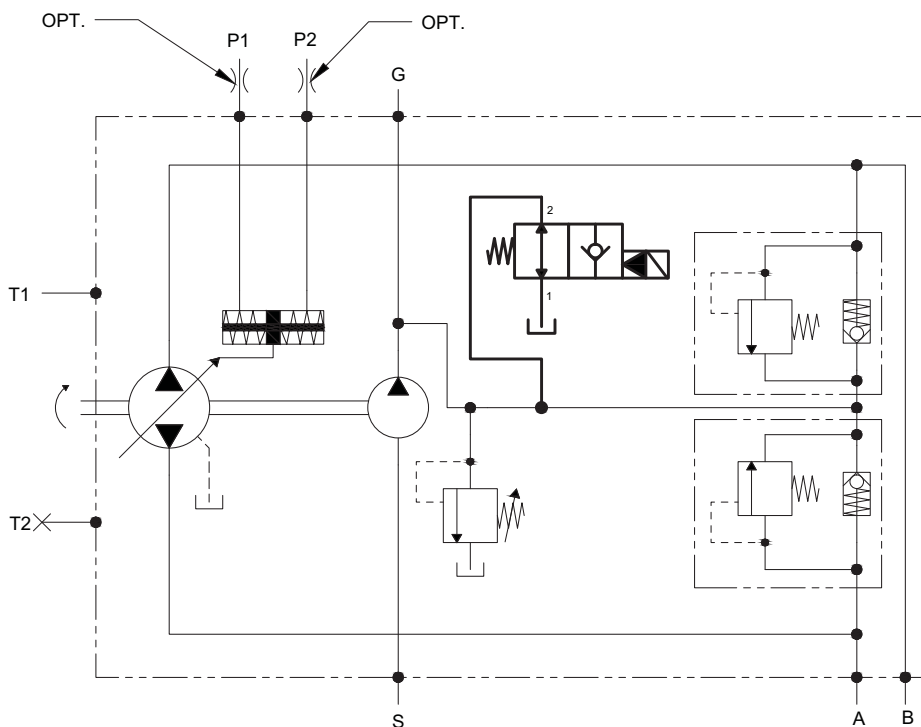

(continued)

# OPTIONAL MOB

MAN ON BOARD

## TECHNICAL FEATURES

VALVE MOB - Hydraulic characteristics	
Max. operating pressure	30 MPa
Max. flow	40 lt/min.
Internal leakage	max. 5 drops/min. at 30 MPa
Response time	energized 20 ms
De-energized	30 ms
Temperature range	from -20°C to 90°C



VALVE MOB - Electrical characteristics	
Power	18 W
Various voltage options available	(AC/DC)
Wire insulation	Class H
Duty factor	ED 100%
Supply power tolerance	+ 10%, - 15% (DC)
Ambient temperature	from -30°C to 60°C
Several connection options available	

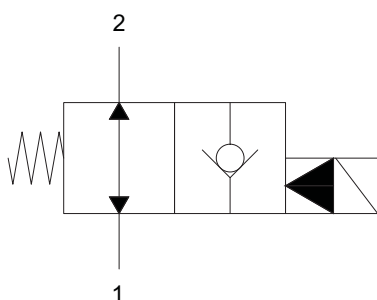



# OPTIONAL RS

## ANGLE SENSOR

An electronic angle sensor, to measure the swash plate position, is available for the TPV-TPVTC 1500 pumps.

The signal can be used for a remote control of the pump performance. The technical features of the sensor are shown on page 48.

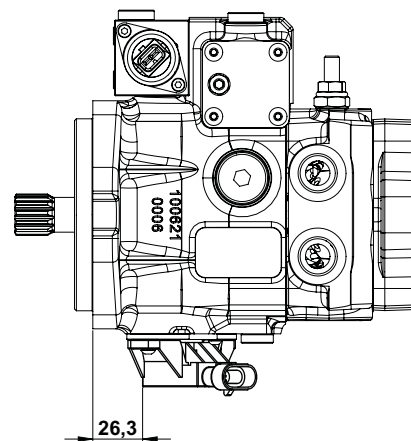
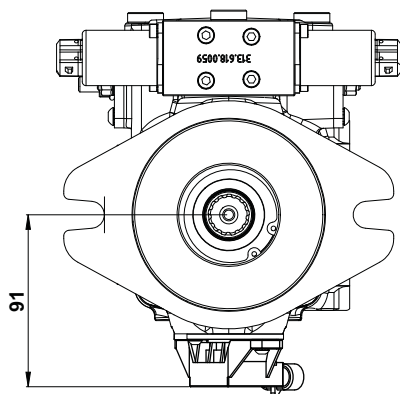
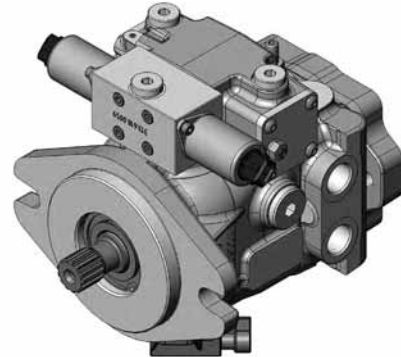

### HYDRAULIC DIAGRAM

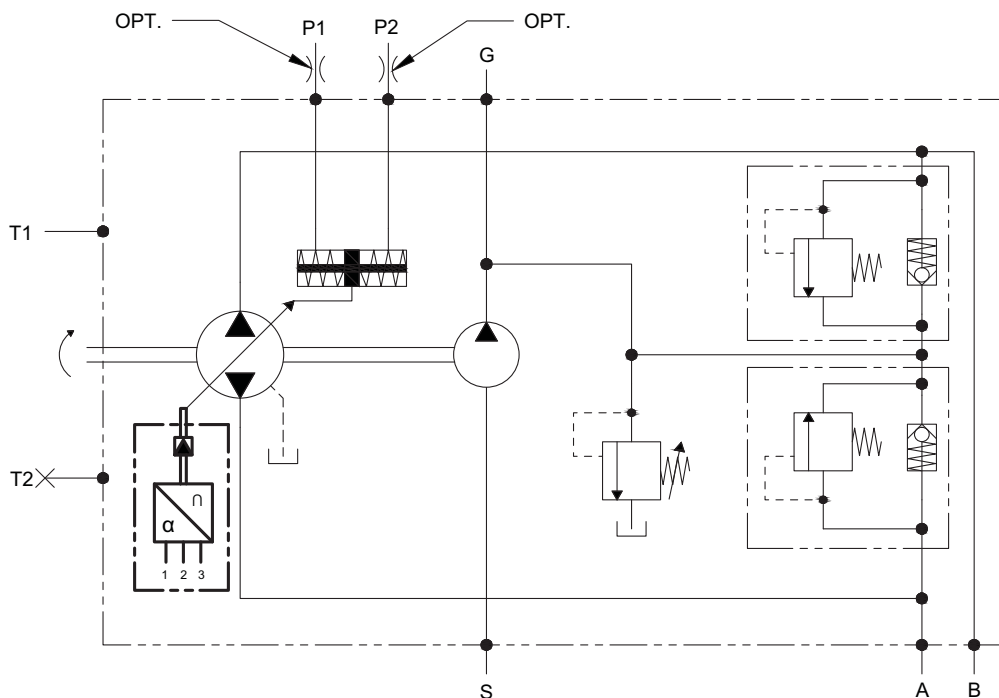

(continued)

# OPTIONAL RS

## ANGLE SENSOR

### TECHNICAL FEATURES

- Operating voltage:** 10-30 V DC
- Output signal:** 0.5-4.5 V
- Current consumption:** 12 V -> 10mA
- Angular range:**  $\pm 25^\circ$
- Resolution (20°C):** 0.1°
- Linearity error (20°C):**  $\pm 0.4^\circ$
- Load resistance:** > 20 k $\Omega$
- Centre position:** 2.5 V
- Reverse connection protected:** yes
- Delay time of output signal:** approx. 3 ms
- Temperature range:** -40 / +85°C

**Offset temperature drift:**

0.3 mV/°C - 1.2  $\mu$ A/°C

**IP protection class:** IP 67

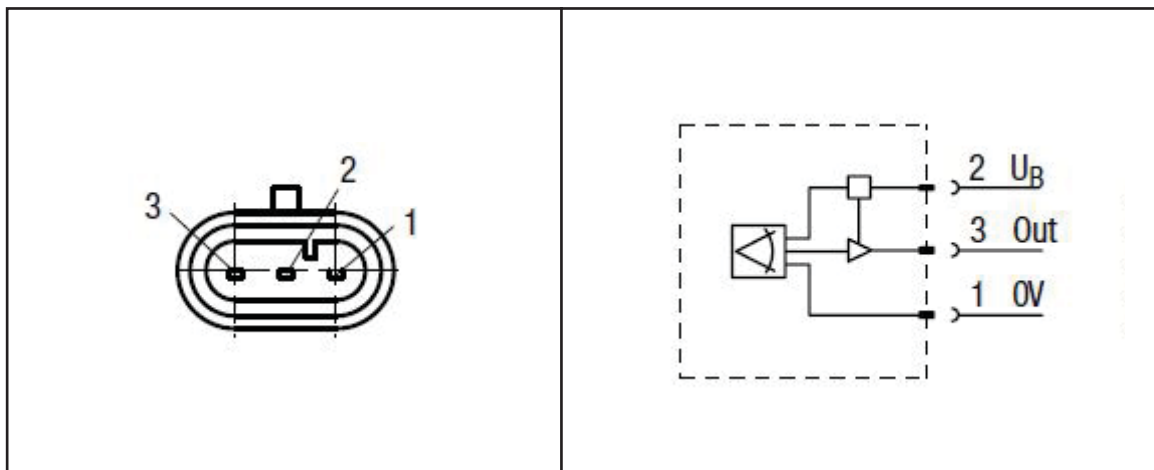

# OPTIONAL REV.S

## SPEED SENSOR

A speed sensor is available to monitor the pump shaft revolution speed. The technical features are shown on page 50.

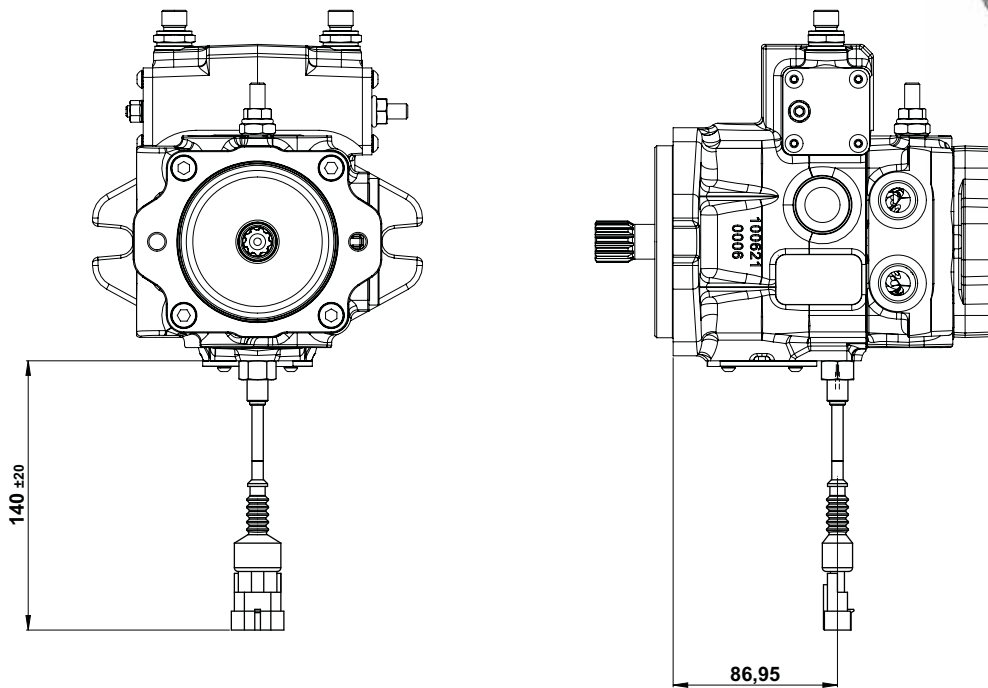
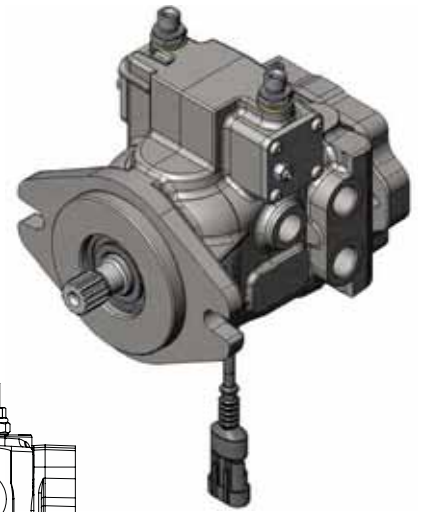

HYDRAULIC DIAGRAM

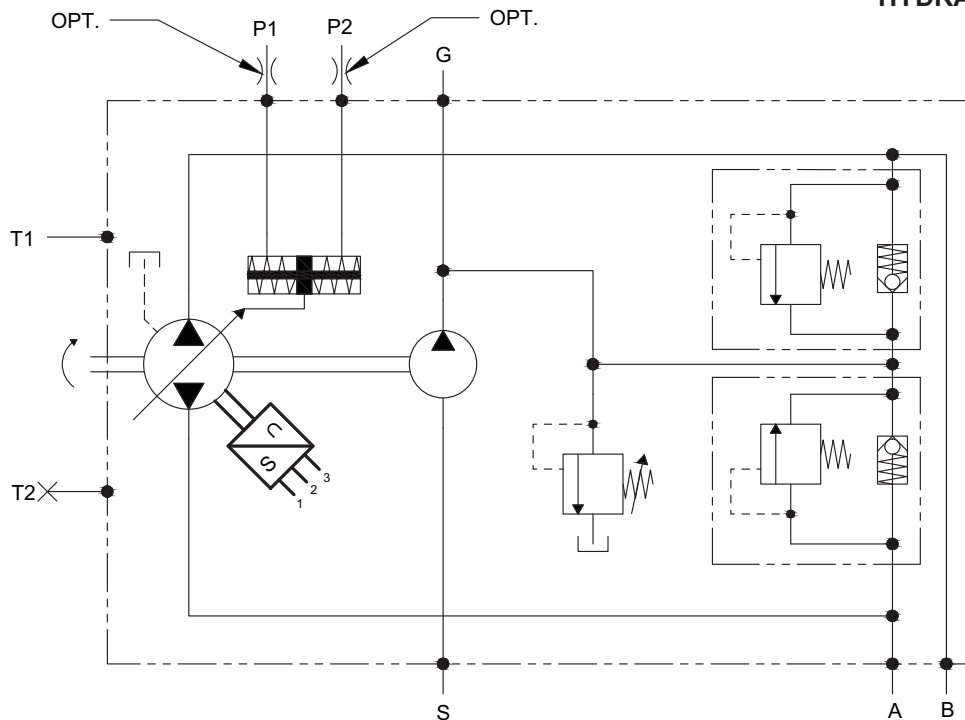

(continued)

# OPTIONAL REV.S

## SPEED SENSOR

### TECHNICAL FEATURES

- Operating voltage:** 4.5-30 V DC
- Output current:** max 25 mA
- Maximum target:** 15 kHz
- Internal resistance:** 140 ±30 Ω
- Insulation resistance:** 145 MΩ (500 V)
- Protected by polarity inversion:** yes
- Output signal (freq):** open collector (NPN)
- Mechanical shock:** 4 g (1mm/80Hz)
- Electro magnetic compatibility:** B.C.I.
- Class "C" 100 mA, 1÷400 MHz
- Reverse polarity protection:** -30 Vdc for 1h
- Overload protection:** 30 mA for 5'
- Overvoltage protection:** 35 V for 5'
- Short circuit protection:** to ground for 5' to Vcc for 5'
- Output transite voltage protection:**  $V_{BR}$  min 31,35 max 34,65

- Temperature range:** -20 / +90°C
- Protection class:** IP 67
- Tightening torque:** 25 Nm
- Output pins are protected against 2000 V electrostatic discharge according to HMB
- Output signal/revolution = 1**

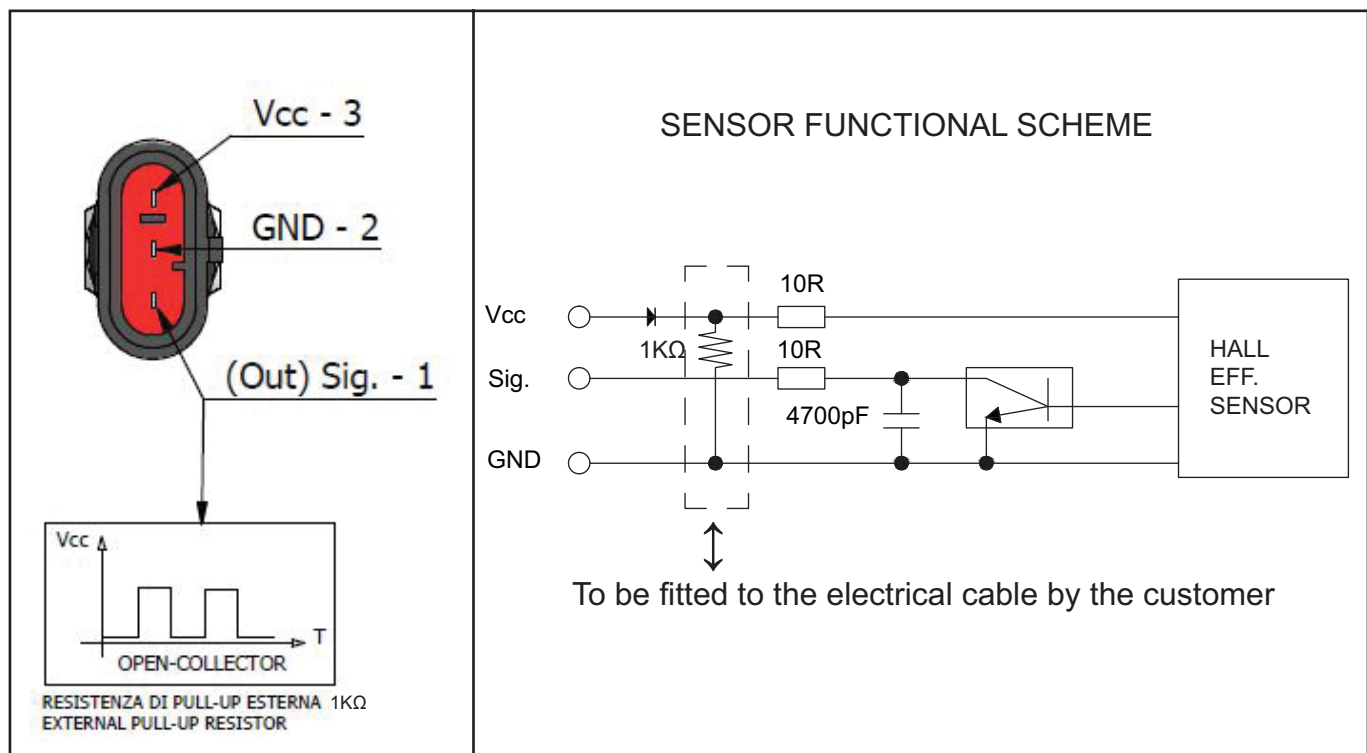

# OPTIONAL PRS

## PRESSURE SENSOR

The TPV-TPVTC 1500 can fit a pressure sensor to monitor the working pressure. These information sent and processed by an electronic remote system allow a continuous remote control of the pump performance. The technical features are shown on pag. 52.

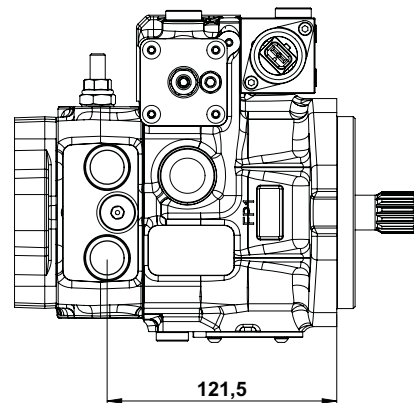
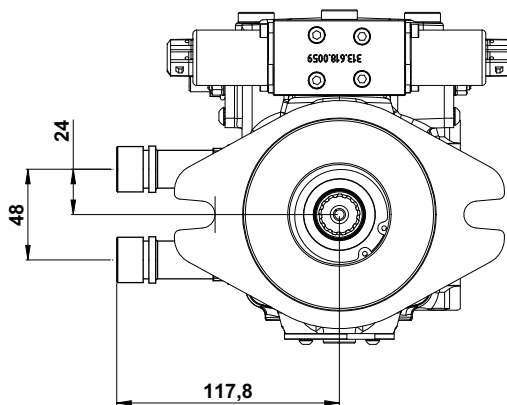
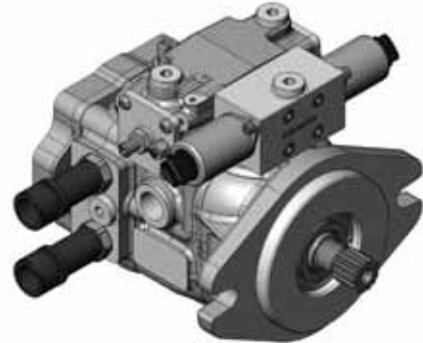

### HYDRAULIC DIAGRAM

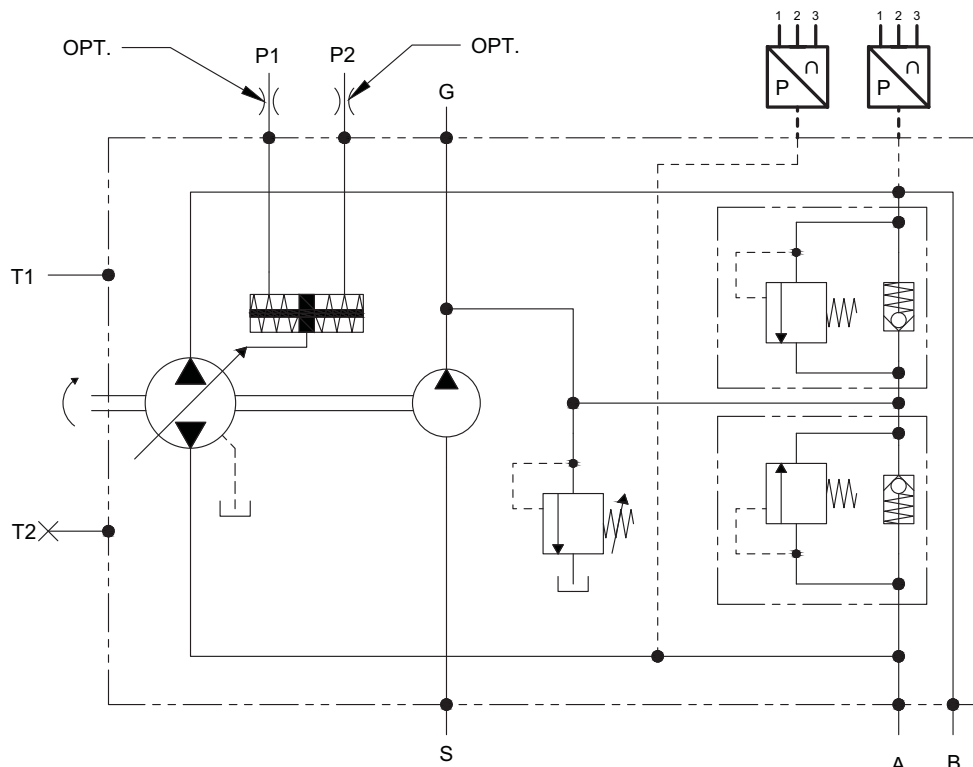

(continued)

# OPTIONAL PRS

## PRESSURE SENSOR

### TECHNICAL FEATURES

**Pressure range:** 0-60 MPa

**Over pressure, max permitted:** 120 MPa

**Burst pressure:** 240 MPa

**Power supply  $U_B$ :** 5.0± 0.5 Volt DC

**Signal output, ratiometric @5V:** min. 0.5 - max. 4.5 Volt DC

**Error levels, signal output:** < 0.5 V and > 4.5 Volt

**Response time:** < 2 ms

**Accuracy (IEC 61298-2):** better than 1%, incl. non-linearity, hysteresis, repeatability, zero point & full scale error

**Max load,  $R_A$ :** > 4.5 kOhm

**Temperature range:**

- ambient, operating from -20 to +90°C
- hydraulic oil inlet from -20 to +90°C
- storage from -20 to +90°C

**CE conformity acc. to:** 89/336/EEC; EN 61326

**Mechanical shock:** 500 g (IEC60068-2-27)

**Vibration resonance:** 20 g (IEC60068-2-6)

**IP protection class:** IP 69K

**Weight:** 70 gr

**Electric connector:** O-ring sealed bayonet 4-way, DIN 72585 97/23/EG

**Hydraulic connection:** G1/4, DIN 3852-E, sealing ring 16.5x11.6x1.5

