

### APPLICATION

Single piston rod double acting cylinder transfers accumulated in a working liquid pressure energy into mechanical energy which puts the piston in reciprocating motion.

When pressure affects the piston area, the piston travels downwards. When pressure affects the piston rod area, the piston returns.

### DIAGRAM

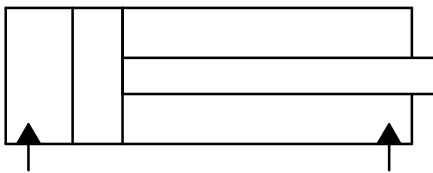

### TECHNICAL DATA

Working fluid	hydraulic fluid (viscosity 10 - 450 mm <sup>2</sup> /s)
Nominal pressure	20 MPa
Required fluid filtration	16 μm
Operating temperature	-30 do 80°C
Max. rod speed	0,5 m/s
Efficiency	> 0,9
Piston rod coating	chrome

# OVERALL DIMENSIONS

Type 3

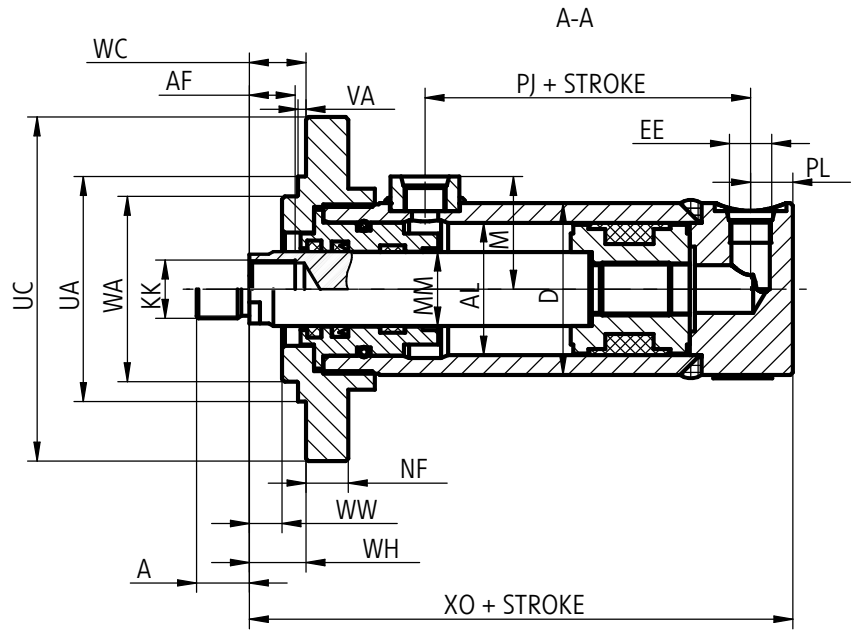
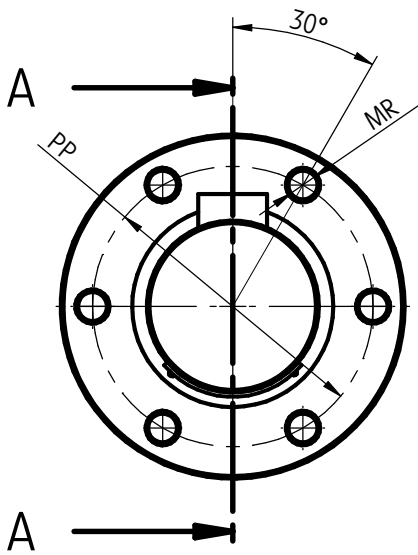

Metric port - PN/M-73101

Inch port - DIN 3852

AL	25	32	40	50	63	80	100	125	140	160	
MM	18	22	22	28	36	45	56	70	80	90	
A	14	16	18	20	22	30	36	45	50	56	
AF	16	22	22	30	36	45	50	63	75	85	
D	35	42	50	65	76	95	120	150	170	195	
EE	M	M14x1,5	M14x1,5	M16x1,5	M16x1,5	M22x1,5	M27x2	M33x2	M33x2	M33x2	M33x2
	G	G 1/4"	G 1/4"	G 3/8"	G 3/8"	G 1/2"	G 3/4"	G 1"	G 1"	G 1"	G 1"
UC	80	105	110	130	160	210	240	280	288	340	
KK	M12x1,5	M16x1,5	M16x1,5	M22x1,5	M27x2	M33x2	M42x2	M48x2	M56x2	M64x2	
WA			60	70	88	108	142	168	183	230	
NF	10	12	14	16	18	19	25	30	30	35	
MR	7	9	9	11	13,5	17	22	22	26	26	
PP	66	85	90	106	130	175	200	230	240	280	
PJ	51,5	60	64	73	85	105	124	138	155	154	
WH	14	14	12	18	20	31	30	32	20	50	
XO	122	132	138	152	180	210	247	271	316	321	
UA	50	60	65	85	100	135	150	180	185	240	
VA	2	2	3	3	3	3	4	4	5	5	
WC	14	14	12	18	20	31	30	32	20	50	
WW	12	12	4	9	7	8	8	23	6	10	
M	31	35	36	42	50	62	75	88	98	110	
PL	13	13	16	17	21	20	27	28	35	32	

EE M for metric port  
EE G for inch port

# OVERALL DIMENSIONS

Type 4

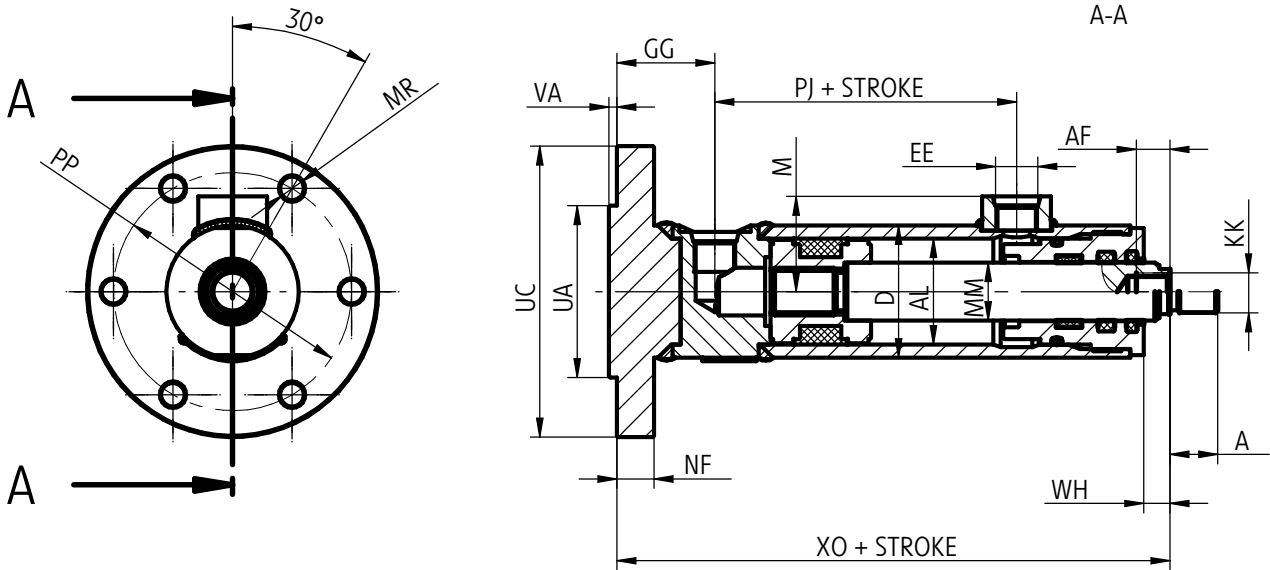

Metric port - PN/M-73101

Inch port - DIN 3852

AL	25	32	40	50	63	80	100	125	140	160	
MM	18	22	22	28	36	45	56	70	80	90	
A	14	16	18	20	22	30	36	45	50	56	
AF	16	22	22	30	36	45	50	63	75	85	
D	35	42	50	65	75	95	120	150	170	195	
EE	M	M14x1,5	M14x1,5	M16x1,5	M16x1,5	M22x1,5	M27x2	M33x2	M33x2	M33x2	M33x2
	G	G 1/4"	G 1/4"	G 3/8"	G 3/8"	G 1/2"	G 3/4"	G 1"	G 1"	G 1"	G 1"
UC	80	105	110	130	160	210	240	280	288	340	
KK	M12x1,5	M16x1,5	M16x1,5	M22x1,5	M27x2	M33x2	M42x2	M48x2	M56x2	M64x2	
MR	7	9	9	11	13,5	17	22	22	26	26	
PP	66	85	90	106	130	175	200	230	240	280	
PJ	58	61	64	73	85	105	124	138	155	154	
WH	12	12	10	15	15	18	20	23	26	36	
XO	132	148	159	178	205	245	284	324,5	361	374	
UA	50	60	65	85	100	135	150	180	185	240	
VA	2	2	3	3	3	3	5	4	5	5	
GG	30	32	37	42	46	55	64	76,5	80	85	
NF	10	12	14	16	18	19	25	30	30	35	
M	31	35	36	42	50	62	75	88	98	110	

EE M for metric port  
EE G for inch port

## HOW TO ORDER

UCJ + -20 + / + \*

Piston hydraulic cylinder

**Mounting:**

flange at cylinder head = 3  
flange at cylinder cap = 4

**Ports:**

metric thread = M  
inch thread = G

**Piston rod end:**

external thread = Z  
internal thread = W

**Nominal pressure MPa**

**Series number**

X5 =X5 (X5-X9)  
installation and connection dimension unchanged

**Piston diameter**

against a table

**Piston rod diameter**

against a table

**Piston stroke**

Futher requirements to be added in text (to agree with manufacturer)

-XXXX

Coding example:

UCJ3-MZ-20-X5-80/45-250

For special requirements please contact the manufacturer.

PONAR Wadowice S.A.  
ul. Wojska Polskiego 29  
34-100 Wadowice  
tel. +48 33 488 21 00  
fax. +48 33 488 21 03  
[www.ponar-wadowice.pl](http://www.ponar-wadowice.pl)

