

APPLICATION

2/2 way cartridge valve type URZS 25... can be used in hydraulic systems as a pilot operated check valve or by combination of several elements as a multiple directional control block.



DESCRIPTION OF OPERATION

2/2 way cartridge valve is comprised of the cartridge insert and the cover (1) with control bores. The cartridge insert consist of the bushing (3), the spring (4) and the poppet: with a damping nose (5) or without a damping nose (6). The poppet is pressed down to valve seat by means of the spring (4). The valve allows free flow from **A** to **B** or reversely from **B** to **A**. The valve poppet has stages. There are three important areas for its operation. The area of the seat **A1** is assumed as **100 %**. The annular area **A2**, resulting from the poppet staging is **7 %** or **50 %** of area **A1**, depending on the version. The area ratio **A1 : A2** is therefore either **14.3 : 1** or **2 : 1**. The area **A3** is **A1 + A2** and can be either **107 %** or **150%** of area **A1**. The area **A3** remains unchanged. When the annular area changes, then the area **A1**, which is regarded as **100 %** also changes. The valve opens in both flow directions if surface **A3** is not affected by pressure (port **X** is unpressurized) and pressure force affecting the adequate surfaces **A1** and **A2** exceeds force of the spring (4). If surface **A3** is affected by control pressure the valve poppet is pressed down to its seat, irrespectively of the spring (4) force. The valve may be opened by unloading surface **A3** or by suitably high pressure in port **A** relatively **B**. The orifice (2) fitted in control line **X** allows to select the opening curve and the valve opening time.

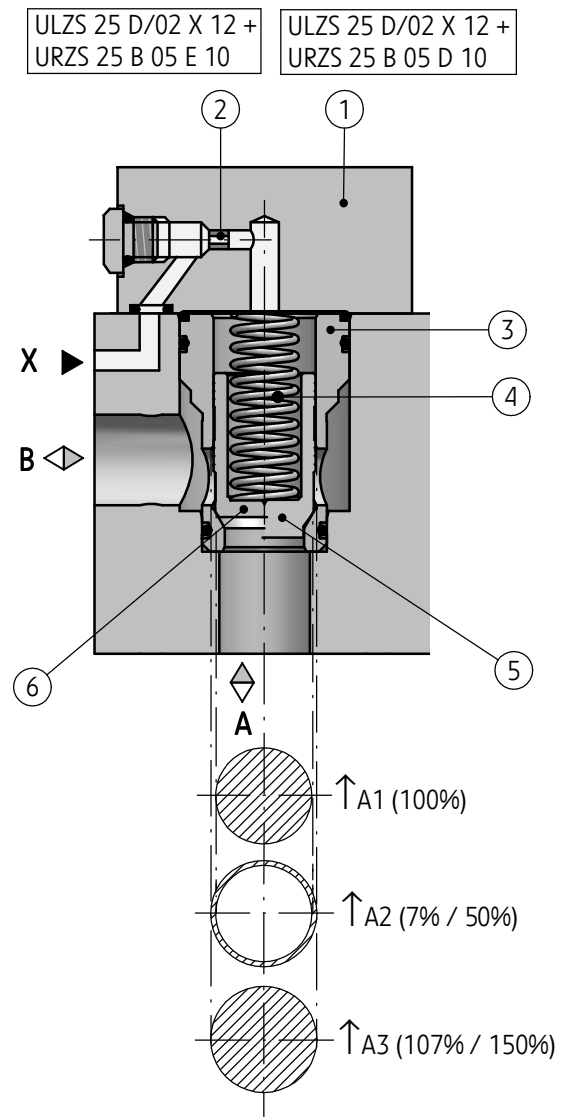

PERFORMANCE CURVES FOR URZS 25

measured at viscosity $\nu = 41 \text{ mm}^2/\text{s}$ and temperature $t = 50 \text{ }^\circ\text{C}$

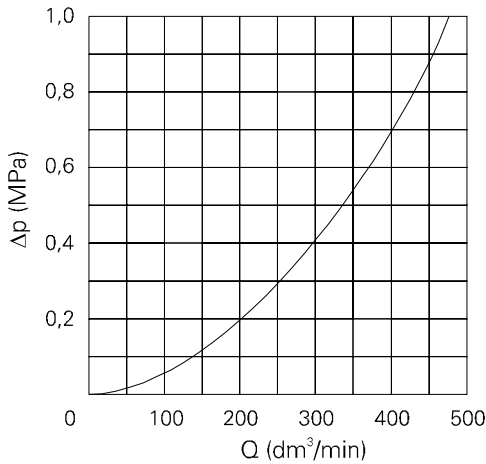

With dumping nose

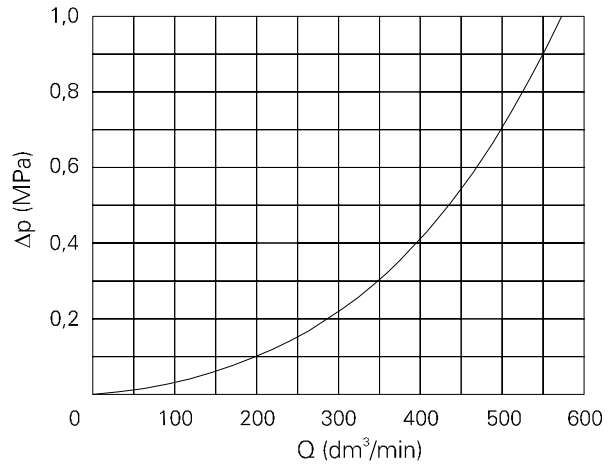

Without dumping nose

SCHEMES

HYDRAULIC SCHEME FOR URZS 25

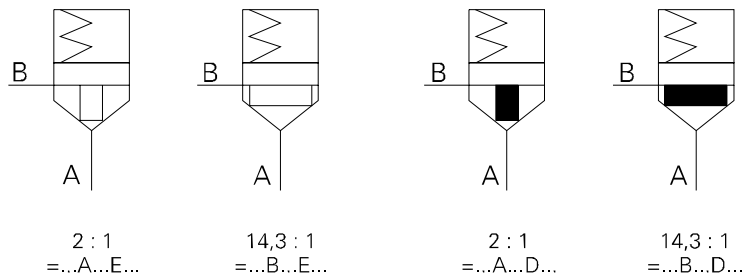

HOW TO ORDER URZS 25

Orders coded in the way showed below should be forwarded to the manufacturer.



Area ratio	
2:1 (50%)	= A
14,3 : 1 (7%)	= B

Cracking pressure	
0 MPa (without spring)	= 0
0,05 MPa	= 05
0,10 MPa	= 10
0,20 MPa	= 20
0,40 MPa	= 40

Valve poppet	
without dumping nose	= E
with dumping nose	= D

Additional requirements in clear text
(to be agreed with the manufacturer)

Sealing	
NBR (fluids on mineral oil base)	= no designation
FKM (fluids on phosphate ester base)	= V

Series number	
(10-19) - installation and connection dimensions unchanged	= 1X
series 10	= 10

NOTE:

The symbols in bold are preferred versions in short delivery time.

Coding example: URZS25 - B - 05 - E - 10

1. COVER ULZS 25 D

OVERALL DIMENSIONS FOR COVER ULZS 25

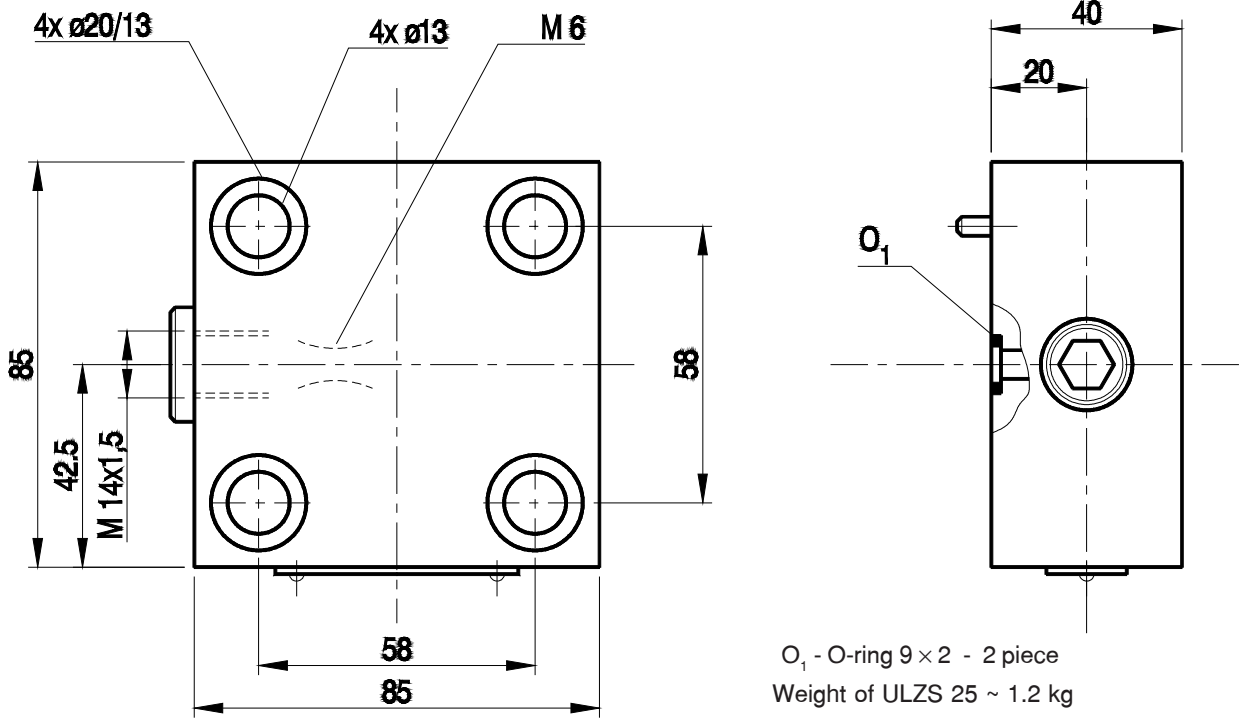

Mounting the cover by means of 4 bolts M12× 50-10.9 PN - 87/M-82302 (DIN 912-10.9).
 Tightening torque $M_d = 110 \text{ Nm}$
 Mounting bolts must be ordered separately.

ORIFICE SELECTION CHART FOR ULZS 25 D

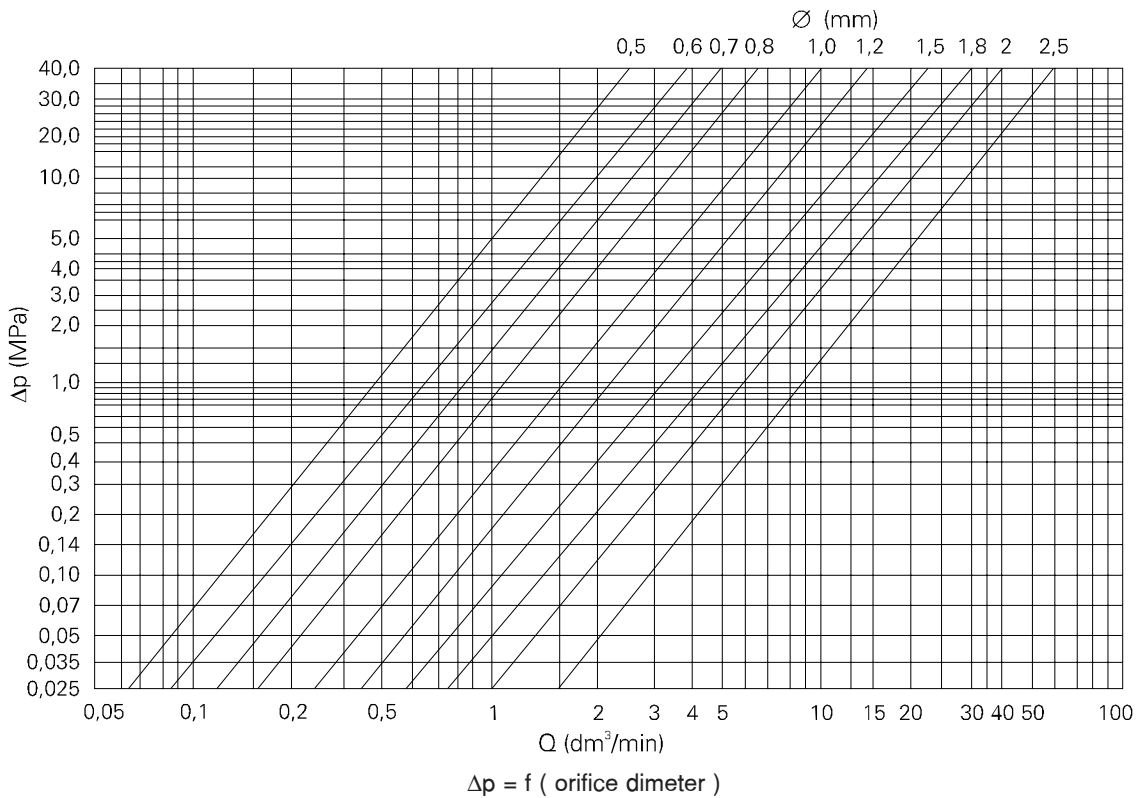

HYDRAULIC SCHEMES FOR ULZS 25 D

ULZS 25 D...

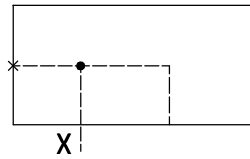

ULZS 25 D...X...

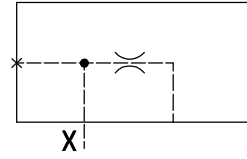

HOW TO ORDER ULZS 25 D

ULZS	25	D	/			*
-------------	-----------	----------	---	--	--	----------

Nominal size (NS) NS25	= 25
Series number (02-09) - connection and installation dimensions unchanged	= 0X = 02
Control port without nozzle	= no designation
with nozzle	= X

Further requirements in dear text (to be agreed with the manufacturer)

Sealing NBR (for fluids on mineral oil base)	= no designation
FKM (for fluids on phosphate ester base)	= V

Orifice diameter	
φ 0,5 mm	= 05
φ 0,6 mm	= 06
φ 0,7 mm	= 07
φ 0,8 mm	= 08
φ 1,0 mm	= 10
φ 1,2 mm	= 12
φ 1,5 mm	= 15
φ 1,8 mm	= 18
φ 2,0 mm	= 20
φ 2,5 mm	= 25

NOTES:

Cover should be ordered according to code, established with symbols according to above diagram.
In case of ordering the cover together with the valve, please quote the codes of the both elements.

Example: ULZS 25 D/02 -12 + URZS 25 B 05 E10

The symbols in bold are preferred versions in short delivery time.

2. Valve cover ULZS 25 WE

OVERALL DIMENSIONS FOR COVER ULZS 25 WE

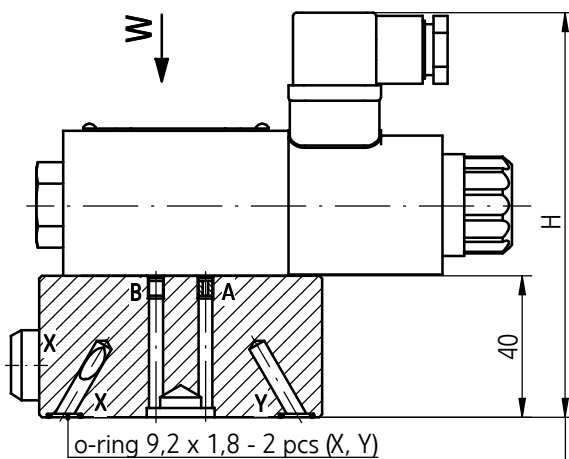

H = 126 - versions: ...G12...; ...G24...; ...G110...
H = 133 - versions: ...W110...; ...W220...; ...W230...

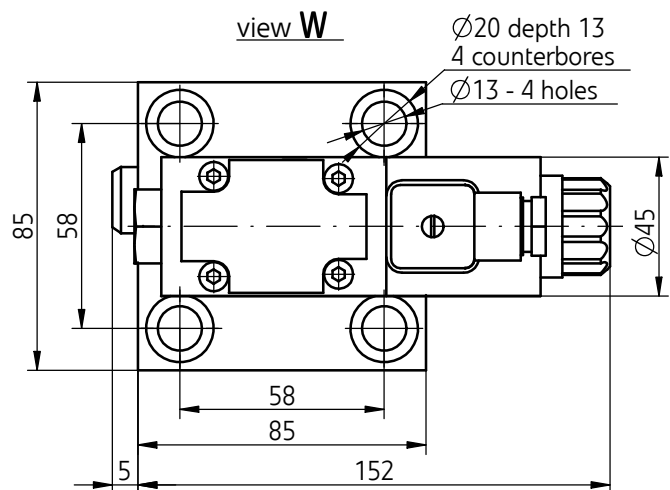

HOW TO ORDER ULZS 25 WE

Orders coded in the way showed below should be forwarded to the manufacturer.



Unloading method
directional valve in de-energized position closed = **A**
directional valve in de-energized position opened = **B**

Series number
 (10-19) - connection and installation dimensions unchanged = 1X
series 13 = **13**

Control line
without orifice = **no designation**
 with orifice in line **A**
 (applicable only for version ULZS25WEA...) = **A**
 with orifice in line **B**
 (applicable only for version ULZS25WEB...) = **B**
 with orifice in line **T** = **T**
 with orifice in line **P** = **P**

Orifice diameter

φ 0,5 mm	= 05
φ 0,6 mm	= 06
φ 0,7 mm	= 07
φ 0,8 mm	= 08
φ 1,0 mm	= 10
φ 1,2 mm	= 12
φ 1,5 mm	= 15
φ 2,0 mm	= 20
φ 2,5 mm	= 25

Further requirements in clear text (to be agreed with the manufacturer)

Sealing
NBR for fluids on mineral oil base = **no designation**
 FKM (for fluids on phosphate ester base) = **V**

Electrical connection - plug-in connector
DIN 43650-A/ISO 4400 without LED = **Z4**
 DIN 43650-A/ISO 4400 with LED = **Z4L**

Manual override of solenoids
 without manual override = no designation
with manual override = **N**

Supply voltage for solenoids

12V DC	= G12
24V DC	= G24
110V DC	= G110
110V AC 50Hz (plug-in connector with rectifier)	= W110R
220V AC 50Hz (plug-in connector with rectifier)	= W220R
230V AC 50Hz (plug-in connector with rectifier)	= W230R

NOTES:

In case of ordering the cover together with the valve, please, quote the codes of the both elements.

Example : ULZS 25 WE A 13 /A 12 W230R + URZS 25 A 10 E 12

The symbols in bold are preferred versions in short delivery time.

SCHEMES

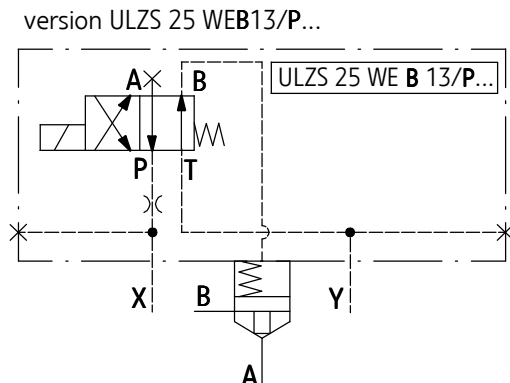
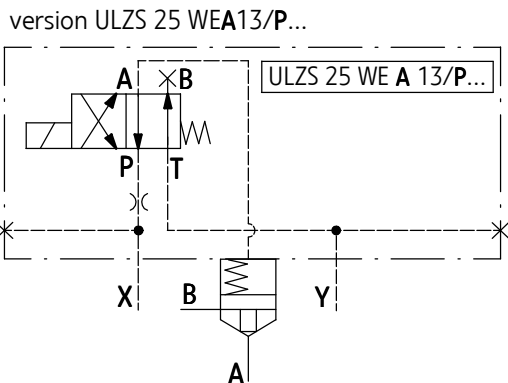

3. COVER ULZS - 25 H
OVERALL DIMENSIONS FOR COVER ULZS 25 H

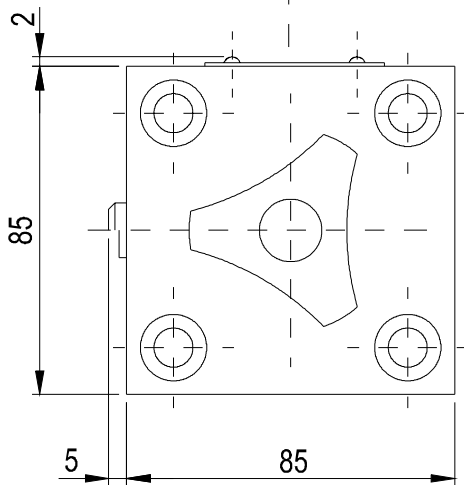
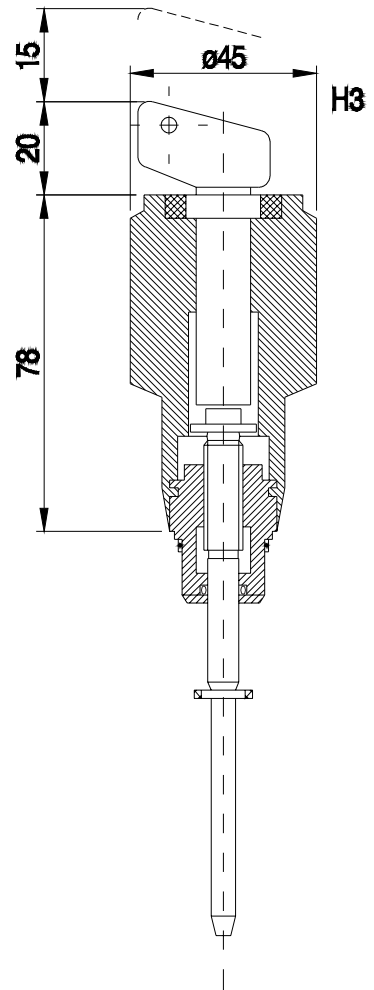
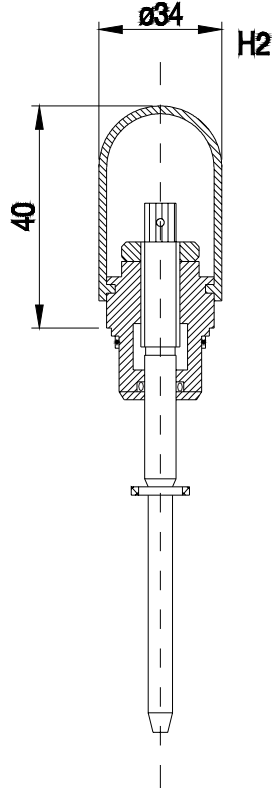
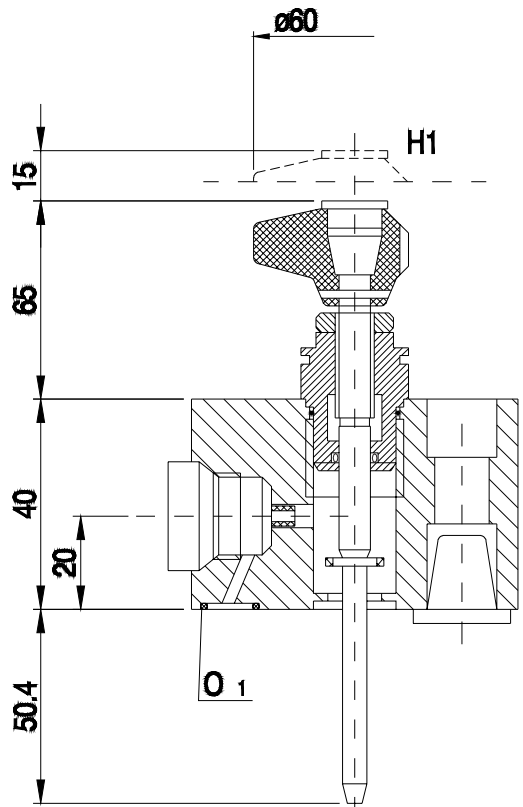

O₁ - O-ring 9,2 x 1,8 - 1 pcs

Weight of ULZS 25 H - approx. 2 kg

DIAGRAMS FOR ULZS 25 H

ULZS - 25H.../...

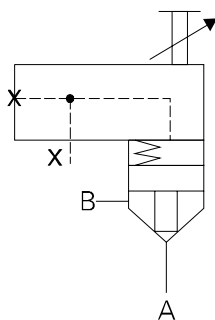

ULZS 25 H.../X...

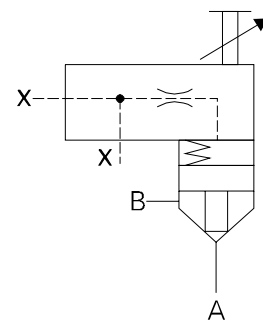

HOW TO ORDER ULZS 25 H

Orders coded in the way showed below should be forwarded to the manufacturer.

ULZS	25	+	/			*
-------------	-----------	----------	----------	--	--	----------

Nominal size of valve cover (NS)

NS25 = **25**

Type of adjustment element

adjustment element 1 = H1

adjustment element 2 = **H2**

adjustment element 3 = H3

Series number

(10-19) - connection and installation dimensions unchanged = 1X

series 10 = **10**

Control line

without orifice = **no designation**

with orifice = X

Orifice diameter

φ 0,5 mm = 05

φ 0,6 mm = 06

φ 0,7 mm = 07

φ 0,8 mm = 08

φ 1,0 mm = 10

φ 1,2 mm = **12**

φ 1,5 mm = 15

φ 2,0 mm = 20

φ 2,5 mm = 25

Sealing

NBR (for fluids on mineral oil base) = **no designation**

FKM (for fluids on phosphate ester base) = **V**

Further requirements in clear text
(to be agreed with the manufacturer)

In case of ordering the cover together with the valve, please, quote the codes of the both elements.

Example : ULZS 25 H2 - 10/12 + URZS25 B 05 E 10

The symbols in bold are preferred versions in short delivery time.

4. Valve cover ULZS 25 DB

OVERALL AND CONNECTION DIMENSIONS

version ULZS 25 DB...

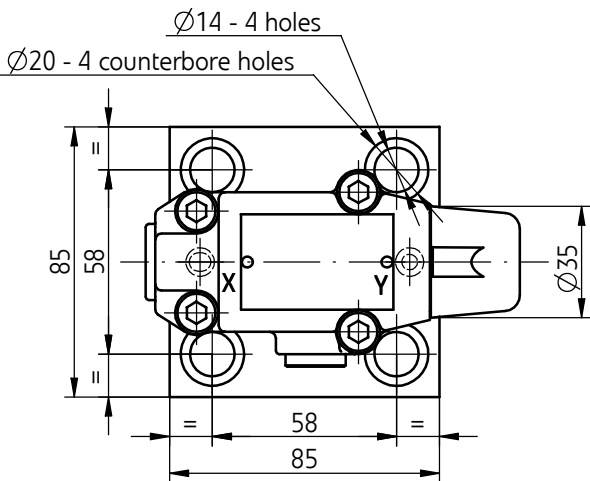
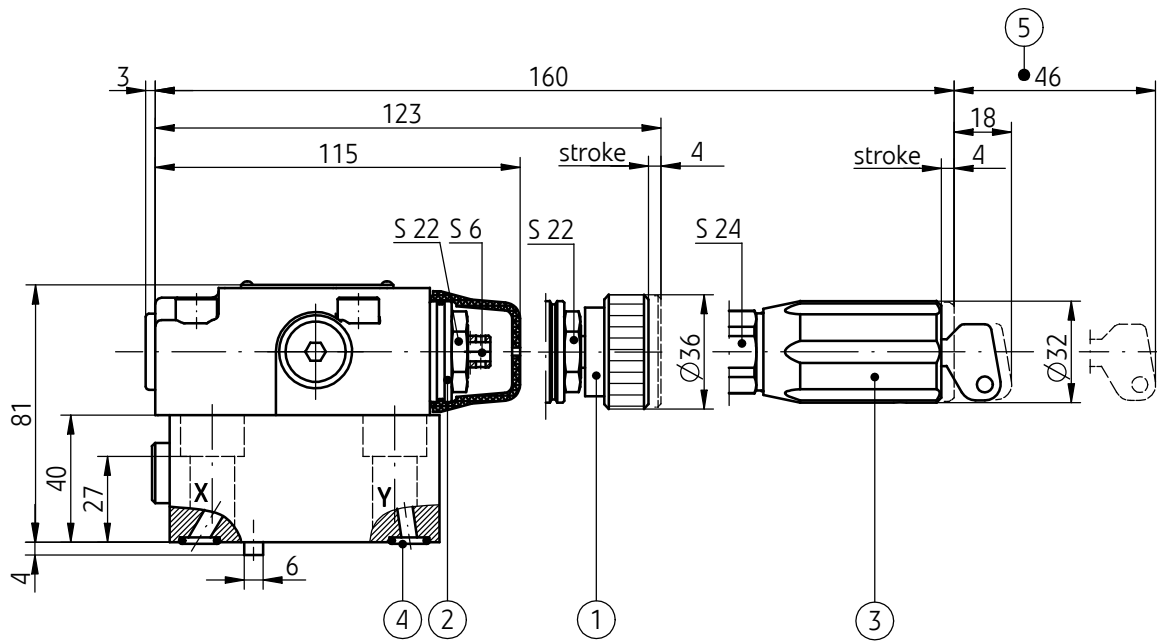

- 1 - Adjustment 1 (handknob)
- 2 - Adjustment 2 (set screw with hexagon socket)
- 3 - Adjustment 3 (lockable handknob)
- 4 - Sealing ring o-ring 9 x 2 - 2 pcs/kit (X, Y)
- 5 - Space required to remove the key from the lock of the adjustment item 3

HOW TO ORDER ULZS 25 DB

ULZS	25	DB				+	/													*
-------------	-----------	-----------	--	--	--	----------	----------	--	--	--	--	--	--	--	--	--	--	--	--	----------

Nominal size of valve cover (NS)

NS25 = 25

Version

without unloading = no designation

with unloading = **W**

Unloading method (only applicable for version ULZS25DBW...)

directional valve in de-energized position closed = **A**

directional valve in de-energized position opened = **B**

Series number

(10-19) - connection and installation dimensions unchanged = 1X

series 12 = **12**

Adjustment element

handknob = 1

set screw with hexagon socket = **2**

lockable handknob = 3

Settable pressure range

up to 5 MPa = 50

up to 10 MPa = **100**

up to 20 MPa = 200

up to 31,5 MPa = **315**

up to 35 MPa = 350

Supply voltage for solenoid (only applicable for version ULZS25DBW...)

12V DC = G12

24V DC = **G24**

110V DC = G110

110V AC 50Hz (plug-in connector with rectifier) = W110R

230V AC 50Hz (plug-in connector with rectifier) = **W230R**

Manual override of solenoid (only applicable for version ULZS25DBW...)

solenoid without manual override = no designation

solenoid with manual override = **N**

Electrical connection - plug-in connector (only applicable for version ULZS25DBW...)

ISO 4400 (DIN 43650 - A) **without LED** = **Z4**

ISO 4400 (DIN 43650 - A) with LED = Z4L

Sealing

NBR (for fluids on mineral oil base) = **no designation**

FKM (for fluids on phosphate ester base) = V

Further requirements in clear text
(to be agreed with the manufacturer)

NOTES:

The valve cover should be ordered according to the above coding.

The symbols in bold are preferred versions in short delivery time.

Coding example of valve cover: ULZS 25 DBW A 12 - 2 /315 G24 Z4

Coding example of valve cover with the valve: ULZS 25 DBW A 12 - 2 /315 G24 N Z4 + URZS 25 B 05 E 10

SCHEMES

Graphic symbols for valve covers type **ULZS 25 DB...**

version **ULZS 25 DBW A...**

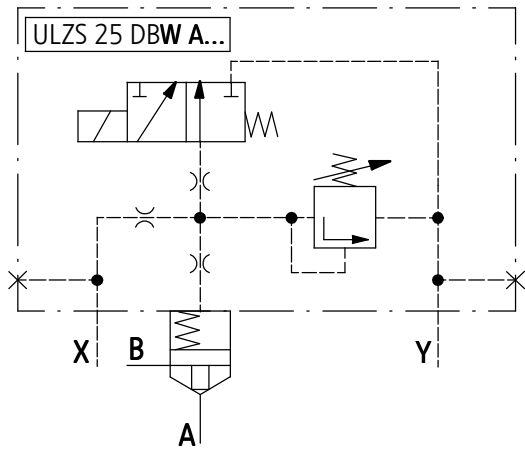

version **ULZS 25 DBW B...**

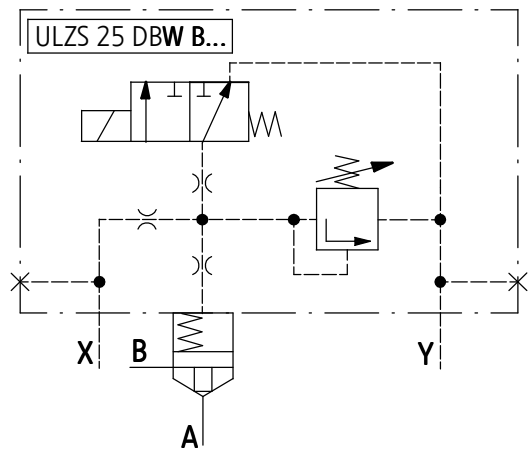

version **ULZS 25 DB...**

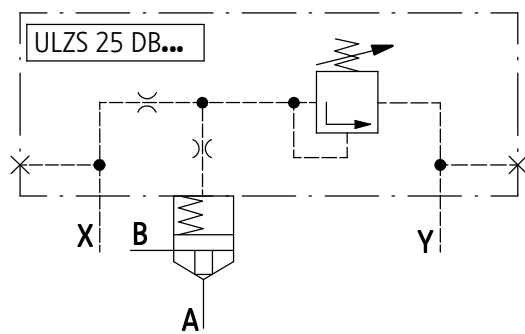

PONAR Wadowice S.A.
 ul. Wojska Polskiego 29
 34-100 Wadowice
 tel. +48 33 488 21 00
 fax. +48 33 488 21 03
www.ponar-wadowice.pl

PONAR[®]
wadowice