

# FILTER UNIT, stationary with plate-exchanger

## Series USP 20 87 PSI

Sheet No.  
4020 C

### Assignment of connections and functions:

- E1: venting mini-measuring connection,  
MA.1.St see sheet-no. 1650
- E2: drainage of filter, dirt side
- E3: drainage of filter, clean side
- M1: measure connection in the housing cover, dirt side  
manometer 0-232 PSI
- M2: measure connection at filter housing  
p<sub>1</sub> = dirt side  
p<sub>2</sub> = clean side
- K1: cooling water IN
- K2: cooling water OUT

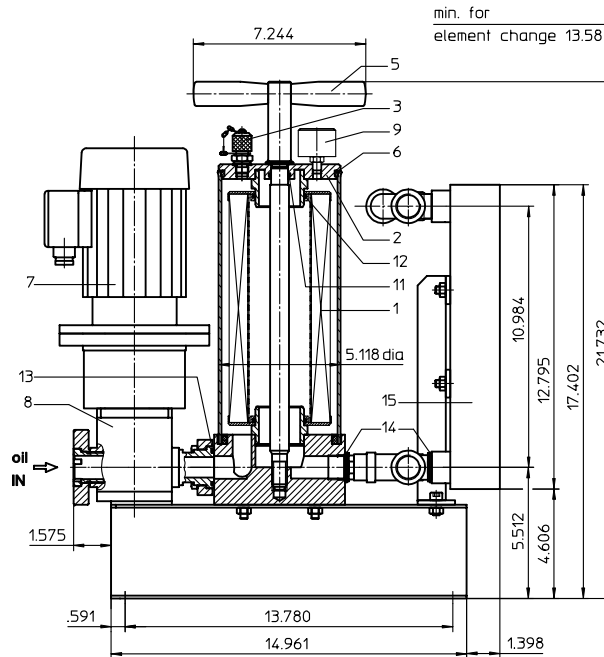
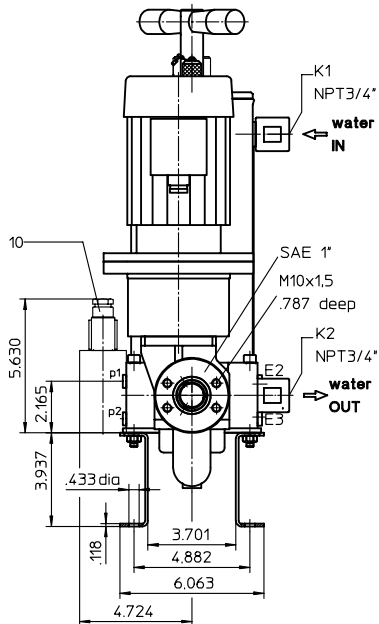
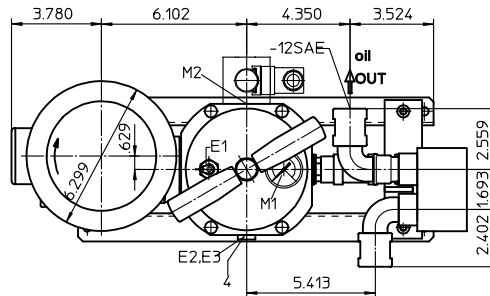

### 1. Type index:

#### 1.1. Filter unit: (ordering example)

**USP. 20. 6VG. 10. B. P. -. P08. W01. CP12. AE**

1	2	3	4	5	6	7	8	9	10	11
---	---	---	---	---	---	---	---	---	----	----

- 1 **series:**  
USP = filter unit, stationary with plate-exchanger
- 2 **nominal size:** 20
- 3 **filter-material and filter-finesness:**  
10 VG = 10 μm<sub>(c)</sub>, 6 VG = 7 μm<sub>(c)</sub>, 3 VG = 5 μm<sub>(c)</sub>, 1 VG = 4 μm<sub>(c)</sub> Interpor fleece (glass fiber)  
10 WVG = 10 μm<sub>(c)</sub>, 3 WVG = 5 μm<sub>(c)</sub> Watersorp-filter element
- 4 **resistance of pressure difference for filter element:**  
10 = Δp 145 PSI
- 5 **filter element design:**  
B = both sides open
- 6 **sealing material:**  
P = Nitrile (NBR)  
V = Viton (FPM), by agreement
- 7 **filter element specification:**  
- = standard  
VA = stainless steel
- 8 **pump unit:**  
P08 = pump unit 08, NG 20.16
- 9 **motor:**  
W01 = B5/71/4.0.37.1800.110.W.60.1.L.-.- alternating current motor 110V, 60 Hz, approx. 1700 RPM, 0.5 HP, type of protection IP 54  
D03 = B5/71/4.0.44.1800.265/460.D.60.1.-.-.- rotary current motor 265/460V, 60 Hz, approx. 1700 RPM, 0.6 HP, type of protection IP 54
- 10 **plate-exchanger unit:**  
CP12 = plate-exchanger unit CP12
- 11 **clogging indicator at M2:**  
- = without  
AE = AE30.2.5.P.-.B electrical at p<sub>1</sub> and p<sub>2</sub>, 36 PSI, see sheet-no. 1609  
AOR = AOR.2.5.P.- visual, 36 PSI, see sheet-no. 1606  
AOC = AOC.2.5.P.- visual, 36 PSI, see sheet-no. 1606

#### 1.2. Filter element: (ordering example)

**01NR. 250. 6VG. 10. B. P. -**

1	2	3	4	5	6	7
---	---	---	---	---	---	---

- 1 **series:**  
01NR. = standard-return-line filter element according to DIN 24550, T4
- 2 **nominal size:** 250
- 3 - 7 see type index-filter unit

Changes of measures and design are subject to alteration!



## 2. Spare parts:

item	designation	qty.	dimension	article-no.
1	filter element	1	01NR, 250	
2	housing cover	1	30615-3	315437
3	mini-measuring connection	1	MA.1.St	305453
4	screw plug	2	¼ BSW	305003
5	straining screw	1	30631-4	316404
6	O-ring	1	115 x 5	306640 (NBR)
7	E-motor D03	1	0.6 HP, 265/460 V	316257
8	pump unit P08	1	NG 20,16	317378
9	manometer (series)	1	1.57 dia	
10	clogging indicator	1	according to type index	
11	O-ring	1	18 x 3	304359 (NBR)
12	O-ring	2	52 x 3	314206 (NBR)
13	O-ring	1	32 x 3,5	304378 (NBR)
14	gasket	2	A 27 x 32	308536
15	plate-exchanger unit	1	CP12	

## 3. Description:

The stationary filter unit with plate-exchanger is intended for oil maintenance and for oil cooling on hydraulic systems.

The area of application comprises:

- secondary flow filtration in addition to the existing operating filter and the oil cooling
- secondary flow filtration without the action of the operating filter and the oil cooling
- filtration when filling the oil reservoir.

The filter unit must not be used to pump contaminated hydraulic fluids and is therefore designed without a switchover fitting to bypass the filter. The compact structural design with plate interlacing without pipe satisfies the prerequisites for small dimensions and high reliability.

The device is equipped with a gear pump driven by an e-motor. The flow conveyed by the geared pump is fed over a filter element to DIN 24550, T4, nominal size 250 and is led afterwards over a plate cooler.

Depending on the customer's wishes, the filter fineness is either 4, 5, 7 or 10 µm<sub>(c)</sub>.

At the measuring point M1, the working pressure before the element is shown. The pollution of the element is indicated with the clogging indicator at the measuring point M2.

At a pressure difference > 36 PSI, the element is polluted and has to be removed with a new element.

The filter element can be changed without tools. After removing the straining screw and taking off the housing cover, the filter element is accessible and it can be exchanged. The filter elements are supplied complete with seals. Since it is not possible to clean the elements, the user must always keep an adequate supply of spare elements in stock.

To protect against overpressure, the filter unit is fitted with a safety valve, pressure setting approx. 87 PSI.

The cooling capacity is shown at the cooling capacity graph for the chosen field of application, depending on the input temperature, the streams of the medium and the type of medium. The cooling capacity graph is intended for the choice of application of the suitable filter unit with cooler. For the fields of application which are not shown in the cooling capacity graph, the capacity data have to be asked for at the manufacturer.

Stationary filter units can be operated without supervision if the electrical connection is fitted with an overload protection corresponding to the current consumption of the selected e-motor and the switch-off function of the e-motor of the electrical clogging indicator will disengaged at 36 PSI.

The line, venting and draining connections are identified according to their function. Drainage is necessary when cleaning the filter unit in connection with the change of filter element, and when setting the medium.

## 4. Symbols:

Filter unit with cooler  
without clogging indicator

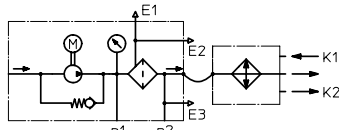

with electrical  
clogging indicator AE30



with visual  
clogging indicator  
AOR, AOC



## 5. Cooling capacity graph:

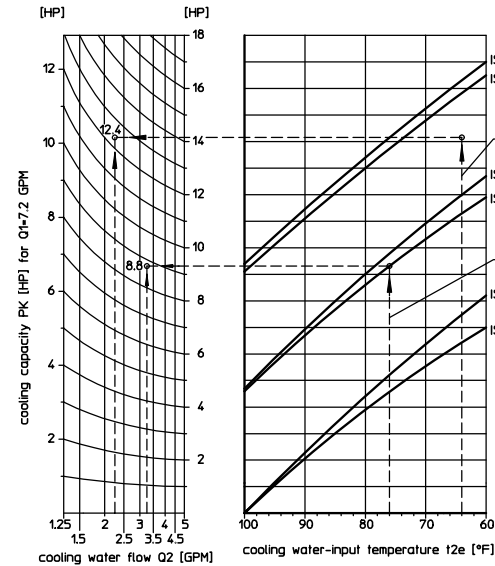

$$\text{operating medium-output temperature } t1a \text{ [°F]} \quad t1a = t1e - \frac{PK * 12.4}{Q1}$$

$$\text{cooling water-output temperature } t2a \text{ [°F]} \quad t2a = t2e + \frac{PK * 5.1}{Q2}$$

example 1, operating medium ISO VG46

$t1e = 120^{\circ}\text{F}$ ,  $t2e = 76^{\circ}\text{F}$ ,  
 $Q1 = 7.2 \text{ GPM}$ ,  $Q2 = 3.25 \text{ GPM}$

cooling capacity PK from the graph = 8.8 HP

$$t1a = 120 - \frac{8.8 * 12.4}{7.2} = 104.8^{\circ}\text{F}$$

$$t2a = 76 + \frac{8.8 * 5.1}{3.25} = 89.8^{\circ}\text{F}$$

example 2, operating medium ISO VG32

$t1e = 130^{\circ}\text{F}$ ,  $t2e = 64^{\circ}\text{F}$ ,  
 $Q1 = 7.2 \text{ GPM}$ ,  $Q2 = 2.25 \text{ GPM}$

cooling capacity PK from the graph = 12.4 HP  
(data linear interpolated)

$$t1a = 130 - \frac{12.4 * 12.4}{7.2} = 108.6^{\circ}\text{F}$$

$$t2a = 64 + \frac{12.4 * 5.1}{2.25} = 96.1^{\circ}\text{F}$$

symbol  
PK = cooling capacity HP  
Q1 = volume flow-operating medium GPM  
Q2 = volume flow-cooling water GPM  
t1e = operating medium-input temperature °F  
t1a = operating medium-output temperature °F  
t2e = cooling water-input temperature °F  
t2a = cooling water-output temperature °F

## 6. Technical data:

pump-volume flow :

7.2 GPM at 1700 RPM

E-motor:

0.6 HP, approx. 1700 RPM

rotary current:

265/460 V, 60 Hz

operating pressure:

max. 87 PSI

filter-fineness:

4, 5, 7 or 10 µm<sub>(c)</sub>

weight:

approx. 77 lbs.

operating medium:

hydraulic oil based on mineral oil from 46 up to 464 SUS,  
other media on request

Classified under the Pressure Vessel Directive 97/23/EC for mineral oil (fluid group 2), Article 3, Para. 3.

Classified under ATEX Directive 94/9/EC according to specific application (see questionnaire sheet-no. 34279-4).

## 7. Test methods:

Filter elements are tested according to the following ISO standards:

ISO 2941 Verification of collapse/burst resistance  
ISO 2942 Verification of fabrication integrity  
ISO 2943 Verification of material compatibility with fluids  
ISO 3723 Method for end load test  
ISO 3724 Verification of flow fatigue characteristics  
ISO 3968 Evaluation of pressure drop versus flow characteristics  
ISO 16889 Multi-pass method for evaluating filtration performance

# FILTER UNIT, stationary with plate-exchanger

## Series USP 41 87 PSI

Sheet No.  
4021 E

### Assignment of connections and functions:

- E1: venting mini-measuring connection,  
MA.1.St see sheet-no. 1650
- E2: drainage of filter, dirt side
- E3: drainage of filter, clean side
- M1: measure connection in the housing cover, dirt side  
manometer 0-232 PSI
- M2: measure connection at filter housing  
p<sub>1</sub> = dirt side  
p<sub>2</sub> = clean side
- K1: cooling water IN
- K2: cooling water OUT

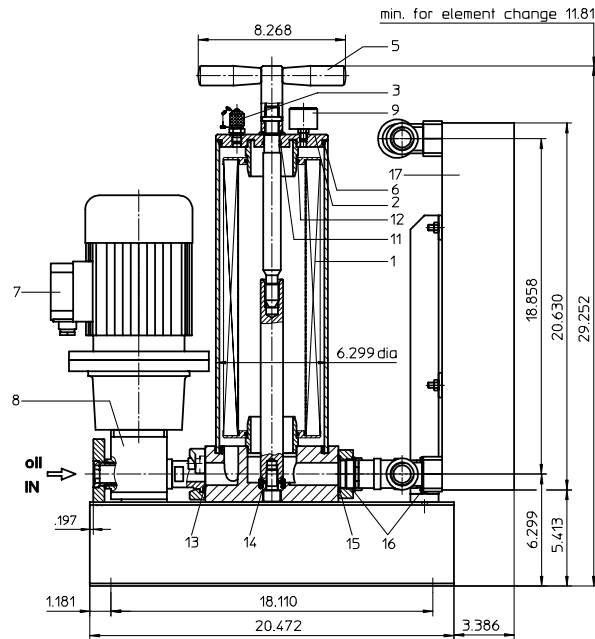
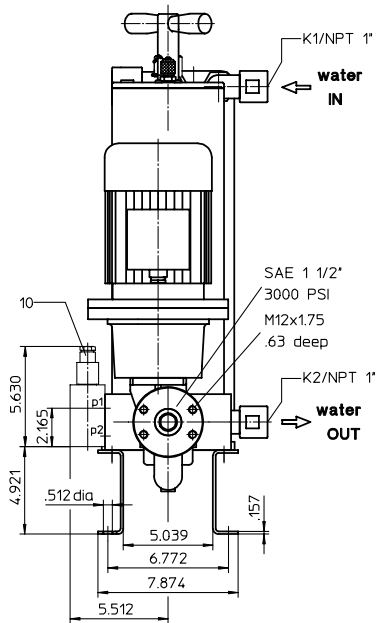
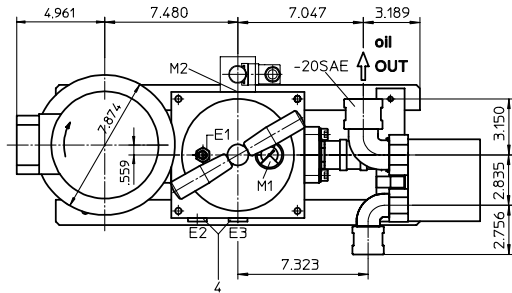

### 1. Type index:

#### 1.1. Filter unit: (ordering example)

**USP. 41. 6VG. 10. B. P. -. P05. D05. CP16. AE**

1	2	3	4	5	6	7	8	9	10	11
---	---	---	---	---	---	---	---	---	----	----

- 1 **series:**  
USP = filter unit, stationary with plate-exchanger
- 2 **nominal size:** 41
- 3 **filter-material and filter-fineness:**  
10 VG = 10  $\mu\text{m}_{(e)}$ , 6 VG = 7  $\mu\text{m}_{(e)}$ , 3 VG = 5  $\mu\text{m}_{(e)}$ , 1 VG = 4  $\mu\text{m}_{(e)}$  Interpor fleece (glass fiber)  
10 WVG = 10  $\mu\text{m}_{(e)}$ , 3 WVG = 5  $\mu\text{m}_{(e)}$  Wassersorp-filter element
- 4 **resistance of pressure difference for filter element:**  
10 =  $\Delta p$  145 PSI
- 5 **filter element design:**  
B = both sides open
- 6 **sealing material:**  
P = Nitrile (NBR)  
V = Viton (FPM), by agreement
- 7 **filter element specification:**  
- = standard  
VA = stainless steel
- 8 **pump unit:**  
P05 = pump unit 05, NG 40.25
- 9 **motor:**  
D05 = B5/80/4.0,9.1800.265/460.D.60.1...- rotary current motor 265/460V, 60 Hz, approx. 1700 RPM, 1.2 HP, type of protection IP 54
- 10 **plate-exchanger unit:**  
CP16 = plate-exchanger unit CP16
- 11 **clogging indicator at M2:**  
- = without  
AE = AE30.2,5.P.-B electrical at p<sub>1</sub> and p<sub>2</sub>, 36 PSI, see sheet-no. 1609  
AOR = AOR.2,5.P.- visual, 36 PSI, see sheet-no. 1606  
AOC = AOC.2,5.P.- visual, 36 PSI, see sheet-no. 1606

#### 1.2. Filter element: (ordering example)

**01NR. 630. 6VG. 10. B. P. -**

1	2	3	4	5	6	7
---	---	---	---	---	---	---

- 1 **series:**  
01NR. = standard-return-line filter element according to DIN 24550, T4
- 2 **nominal size:** 630
- 3 - 7 see type index-filter unit

Changes of measures and design are subject to alteration!

## 2. Spare parts:

item	designation	qty.	dimension	article-no.
1	filter element	1	01NR. 630	
2	housing cover	1	30600-3	315492
3	mini-measuring connection	1	MA.1.St	305453
4	screw plug	2	½ BSPP	304678
5	straining screw	1	30595-3	316312
6	O-ring	1	140 x 6	315392 (NBR)
7	E-motor D05	1	1.2 HP, 265/460 V	311537
8	pump unit P01	1	NG 40.25	316292
9	manometer (series)	1	1.57 dia	
10	clogging indicator	1	according to type index	
11	O-ring	1	22 x 3	304387 (NBR)
12	O-ring	2	70 x 4	306253 (NBR)
13	O-ring	1	37,69 x 3,53	304353 (NBR)
14	O-ring	1	18 x 3	304359 (NBR)
15	O-ring	1	44,45 x 3,53	317607 (NBR)
16	gasket	2	A 42 x 49	308541
17	plate-exchanger unit	1	CP16	

## 3. Description:

The stationary filter unit with plate-exchanger is intended for oil maintenance and for oil cooling on hydraulic systems. The area of application comprises:

- secondary flow filtration in addition to the existing operating filter and the oil cooling
- secondary flow filtration without the action of the operating filter and the oil cooling
- filtration when filling the oil reservoir.

The filter unit must not be used to pump contaminated hydraulic fluids and is therefore designed without a switchover fitting to bypass the filter. The compact structural design with plate interlacing without pipe satisfies the prerequisites for small dimensions and high reliability.

The device is equipped with a gear pump driven by an e-motor. The flow conveyed by the geared pump is fed over a filter element to DIN 24550, T4, nominal size 630 and is led afterwards over a plate cooler.

Depending on the customer's wishes, the filter fineness is either 4, 5, 7 or 10 µm (φ).

At the measuring point M1, the working pressure before the element is shown. The pollution of the element is indicated with the clogging indicator at the measuring point M2.

At a pressure difference > 36 PSI, the element is polluted and has to be removed with a new element.

The filter element can be changed without tools. After removing the straining screw and taking off the housing cover, the filter element is accessible and it can be exchanged. The filter elements are supplied complete with seals. Since it is not possible to clean the elements, the user must always keep an adequate supply of spare elements in stock.

To protect against overpressure, the filter unit is fitted with a safety valve, pressure setting approx. 87 PSI.

The cooling capacity is shown at the cooling capacity graph for the chosen field of application, depending on the input temperature, the streams of the medium and the type of medium. The cooling capacity graph is intended for the choice of application of the suitable filter unit with cooler. For the fields of application which are not shown in the cooling capacity graph, the capacity data have to be asked for at the manufacturer.

Stationary filter units can be operated without supervision if the electrical connection is fitted with an overload protection corresponding to the current consumption of the selected e-motor and the switch-off function of the e-motor of the electrical clogging indicator will disengaged at 36 PSI.

The line, venting and draining connections are identified according to their function. Drainage is necessary when cleaning the filter unit in connection with the change of filter element, and when setting the medium.

## 4. Symbols:

Filter unit with cooler  
without clogging indicator

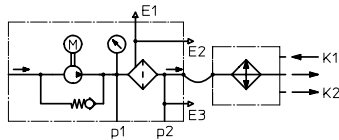

with electrical  
clogging indicator AE30



with visual  
clogging indicator  
AOR, AOC



## 5. Cooling capacity graph:

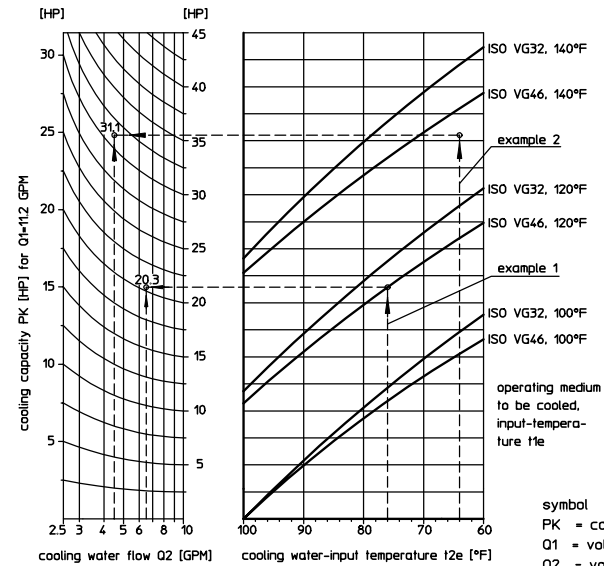

example 1. operating medium ISO VG46

t1e = 120°F, t2e = 76°F,  
Q1 = 11.2 GPM, Q2 = 6.5 GPM

cooling capacity PK from the graph = 20.3 HP

t1a = 120 -  $\frac{20.3 * 12.4}{11.2}$  = 97.5°F

t2a = 76 +  $\frac{20.3 * 5.1}{6.5}$  = 91.9°F

example 2. operating medium ISO VG32

t1e = 130°F, t2e = 64°F,  
Q1 = 11.2 GPM, Q2 = 4.5 GPM

cooling capacity PK from the graph = 31.1 HP  
(data linear interpolated)

t1a = 130 -  $\frac{31.1 * 12.4}{11.2}$  = 95.6°F

t2a = 64 +  $\frac{31.1 * 5.1}{4.5}$  = 99.2°F

symbol	units
PK = cooling capacity	HP
Q1 = volume flow-operating medium	GPM
Q2 = volume flow-cooling water	GPM
t1e = operating medium-input temperature	°F
t1a = operating medium-output temperature	°F
t2e = cooling water-input temperature	°F
t2a = cooling water-output temperature	°F

$$\text{operating medium-output temperature } t1a \text{ [°F]} \quad t1a = t1e - \frac{PK * 12.4}{Q1}$$

$$\text{cooling water-output temperature } t2a \text{ [°F]} \quad t2a = t2e + \frac{PK * 5.1}{Q2}$$

## 6. Technical data:

pump-volume flow :	11.2 GPM at 1700 RPM
E-motor:	1.2 HP, approx. 1700 RPM
rotary current:	265/460 V, 60 Hz
operating pressure:	max. 87 PSI
filter-fineness:	4, 5, 7 or 10 µm(φ)
weight:	approx. 128 lbs.
operating medium:	hydraulic oil based on mineral oil from 46 up to 464 SUS, other media on request

Classified under the Pressure Vessel Directive 97/23/EC for mineral oil (fluid group 2), Article 3, Para. 3.  
Classified under ATEX Directive 94/9/EC according to specific application (see questionnaire sheet-no. 34279-4).

## 7. Test methods:

Filter elements are tested according to the following ISO standards:

ISO 2941	Verification of collapse/burst resistance
ISO 2942	Verification of fabrication integrity
ISO 2943	Verification of material compatibility with fluids
ISO 3723	Method for end load test
ISO 3724	Verification of flow fatigue characteristics
ISO 3968	Evaluation of pressure drop versus flow characteristics
ISO 16889	Multi-pass method for evaluating filtration performance

# FILTER UNIT, stationary with plate-exchanger

## Series USP 81 87 PSI

Sheet No.  
4022 E

### Assignment of connections and functions:

- E1: venting mini-measuring connection, MA.1.St see sheet-no. 1650
- E2: drainage of filter, dirt side
- E3: drainage of filter, clean side
- M1: measure connection in the housing cover, dirt side manometer 0-232 PSI
- M2: measure connection at filter housing
  - p<sub>1</sub> = dirt side
  - p<sub>2</sub> = clean side
- K1: cooling water IN
- K2: cooling water OUT

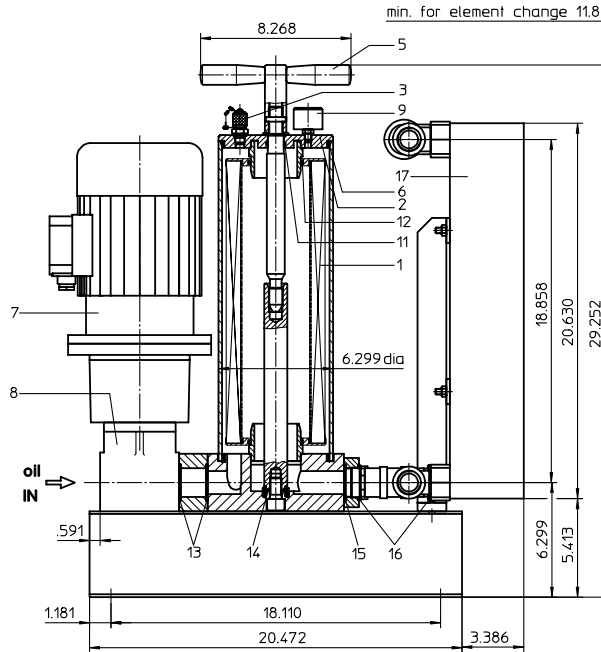
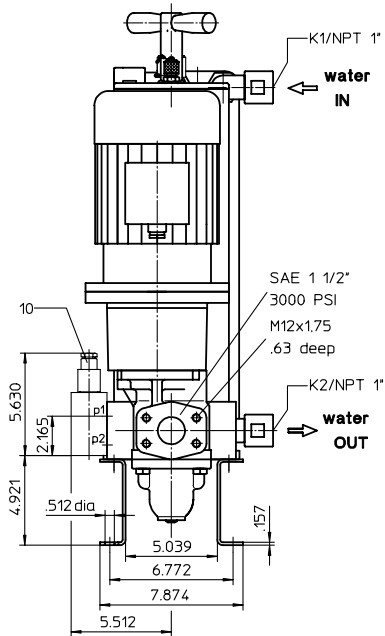
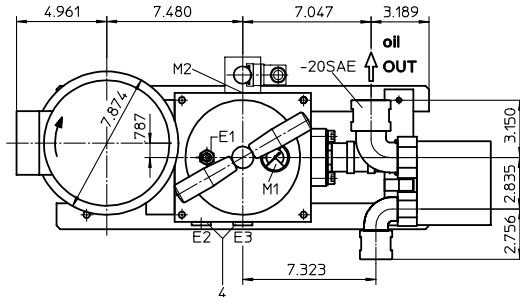

### 1. Type index:

#### 1.1. Filter unit: (ordering example)

**USP. 81. 6VG. 10. B. P. -. P04. D01. CP18. AE**

1	2	3	4	5	6	7	8	9	10	11
---	---	---	---	---	---	---	---	---	----	----

- 1 series:  
USP = filter unit, stationary with plate-exchanger
- 2 nominal size: 81
- 3 filter-material and filter-finness:  
10 VG = 10 μm<sub>(c)</sub>, 6 VG = 7 μm<sub>(c)</sub>, 3 VG = 5 μm<sub>(c)</sub>, 1 VG = 4 μm<sub>(c)</sub> Interpor fleece (glass fiber)  
10 WVG = 10 μm<sub>(c)</sub>, 3 WVG = 5 μm<sub>(c)</sub> Watersorp-filter element
- 4 resistance of pressure difference for filter element:  
10 = Δp 145 PSI
- 5 filter element design:  
B = both sides open
- 6 sealing material:  
P = Nitrile (NBR)  
V = Viton (FPM), by agreement
- 7 filter element specification:  
- = standard  
VA = stainless steel
- 8 pump unit:  
P04 = pump unit 04, NG 80.50
- 9 motor:  
D01 = B5/90L/4.1.8.1800.265/460.D.60.1.-.-.- rotary current motor 265/460V, 60 Hz, approx. 1700 RPM, 2.4 HP, type of protection IP 54
- 10 plate-exchanger unit:  
CP18 = plate-exchanger unit CP18
- 11 clogging indicator at M2:  
- = without  
AE = AE30.2.5.P.-B electrical at p<sub>1</sub> and p<sub>2</sub>, 36 PSI, see sheet-no. 1609  
AOR = AOR.2.5.P.- visual, 36 PSI, see sheet-no. 1606  
AOC = AOC.2.5.P.- visual, 36 PSI, see sheet-no. 1606

#### 1.2. Filter element: (ordering example)

**01NR. 630. 6VG. 10. B. P. -**

1	2	3	4	5	6	7
---	---	---	---	---	---	---

- 1 series:  
01NR. = standard-return-line filter element according to DIN 24550, T4
- 2 nominal size: 630
- 3 - 7 see type index-filter unit

Changes of measures and design are subject to alteration!



## 2. Spare parts:

item	designation	qty.	dimension	article-no.
1	filter element	1	01NR. 630	
2	housing cover	1	30600-3	315492
3	mini-measuring connection	1	MA.1.St	305453
4	screw plug	2	½ BSPP	304678
5	straining screw	1	30595-3	316312
6	O-ring	1	140 x 6	315392 (NBR)
7	E-motor D01	1	2.4 HP, 265/460 V	313465
8	pump unit P04	1	NG 80.50	317139
9	manometer (series)	1	1.57 dia	
10	clogging indicator	1	according to type index	
11	O-ring	1	22 x 3	304387 (NBR)
12	O-ring	2	70 x 4	306253 (NBR)
13	O-ring	2	45 x 3	304991 (NBR)
14	O-ring	1	18 x 3	304359 (NBR)
15	O-ring	1	44,45 x 3,53	317607 (NBR)
16	gasket	2	A 42 x 49	308541
17	plate-exchanger unit	1	CP18	

## 3. Description:

The stationary filter unit with plate-exchanger is intended for oil maintenance and for oil cooling on hydraulic systems. The area of application comprises:

- secondary flow filtration in addition to the existing operating filter and the oil cooling
- secondary flow filtration without the action of the operating filter and the oil cooling
- filtration when filling the oil reservoir.

The filter unit must not be used to pump contaminated hydraulic fluids and is therefore designed without a switchover fitting to bypass the filter. The compact structural design with plate interlacing without pipe satisfies the prerequisites for small dimensions and high reliability.

The device is equipped with a gear pump driven by an e-motor. The flow conveyed by the geared pump is fed over a filter element to DIN 24550, T4, nominal size 630 and is led afterwards over a plate cooler.

Depending on the customer's wishes, the filter fineness is either 4, 5, 7 or 10 µm<sub>(e)</sub>.

At the measuring point M1, the working pressure before the element is shown. The pollution of the element is indicated with the clogging indicator at the measuring point M2.

At a pressure difference > 36 PSI, the element is polluted and has to be removed with a new element.

The filter element can be changed without tools. After removing the straining screw and taking off the housing cover, the filter element is accessible and it can be exchanged. The filter elements are supplied complete with seals. Since it is not possible to clean the elements, the user must always keep an adequate supply of spare elements in stock.

To protect against overpressure, the filter unit is fitted with a safety valve, pressure setting approx. 87 PSI.

The cooling capacity is shown at the cooling capacity graph for the chosen field of application, depending on the input temperature, the streams of the medium and the type of medium. The cooling capacity graph is intended for the choice of application of the suitable filter unit with cooler. For the fields of application which are not shown in the cooling capacity graph, the capacity data have to be asked for at the manufacturer.

Stationary filter units can be operated without supervision if the electrical connection is fitted with an overload protection corresponding to the current consumption of the selected e-motor and the switch-off function of the e-motor of the electrical clogging indicator will disengaged at 36 PSI.

The line, venting and draining connections are identified according to their function. Drainage is necessary when cleaning the filter unit in connection with the change of filter element, and when setting the medium.

## 4. Symbols:

Filter unit with cooler  
without clogging indicator

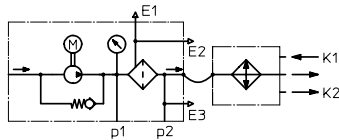

with electrical  
clogging indicator AE30



with visual  
clogging indicator  
AOR, AOC



## 5. Cooling capacity graph:

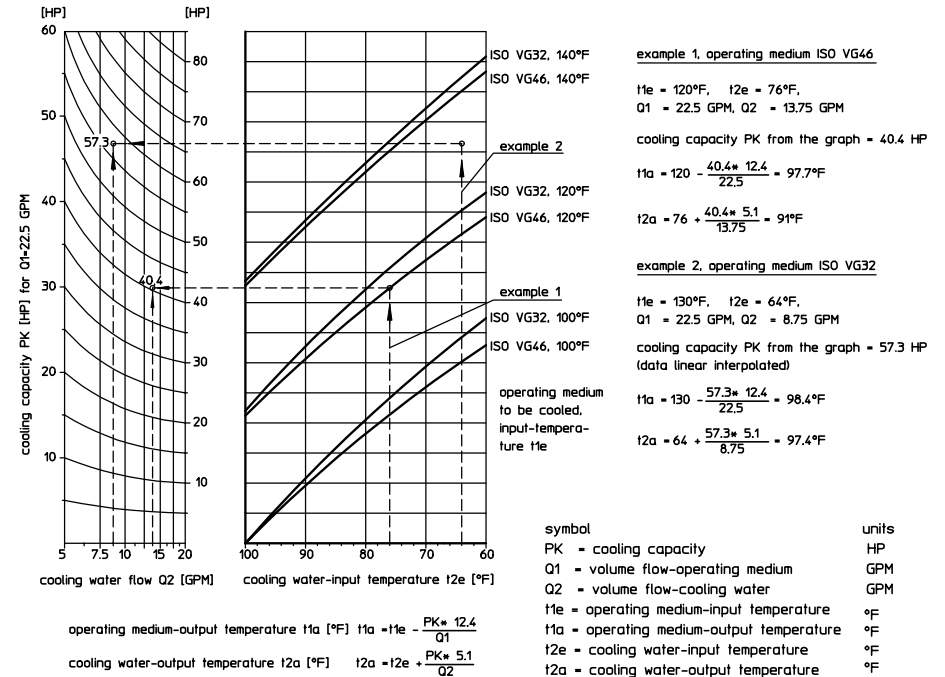

## 6. Technical data:

pump-volume flow : 22.5 GPM at 1700 RPM  
 E-motor: 2.4 HP, approx. 1700 RPM  
 rotary current: 265/460 V, 60 Hz  
 operating pressure: max. 87 PSI  
 filter-fineness: 4, 5, 7 or 10 µm<sub>(e)</sub>  
 weight: approx. 176 lbs.  
 operating medium: hydraulic oil based on mineral oil from 46 up to 464 SUS,  
 other media on request

Classified under the Pressure Vessel Directive 97/23/EC for mineral oil (fluid group 2), Article 3, Para. 3.  
 Classified under ATEX Directive 94/9/EC according to specific application (see questionnaire sheet-no. 34279-4).

## 7. Test methods:

Filter elements are tested according to the following ISO standards:

ISO 2941 Verification of collapse/burst resistance  
 ISO 2942 Verification of fabrication integrity  
 ISO 2943 Verification of material compatibility with fluids  
 ISO 3723 Method for end load test  
 ISO 3724 Verification of flow fatigue characteristics  
 ISO 3968 Evaluation of pressure drop versus flow characteristics  
 ISO 16889 Multi-pass method for evaluating filtration performance

# FILTER UNIT, stationary with plate-exchanger

## Series USP 161 116 PSI

Sheet No.  
4023 E

### Assignment of connections and functions:

- E1: venting mini-measuring connection, MA.1.St see sheet-no. 1650
- E2: drainage of filter, dirt side
- E3: drainage of filter, clean side
- M1: measure connection in the housing cover, dirt side manometer 0-232 PSI
- M2: measure connection at filter housing  
p<sub>1</sub> = dirt side  
p<sub>2</sub> = clean side
- K1: cooling water IN
- K2: cooling water OUT

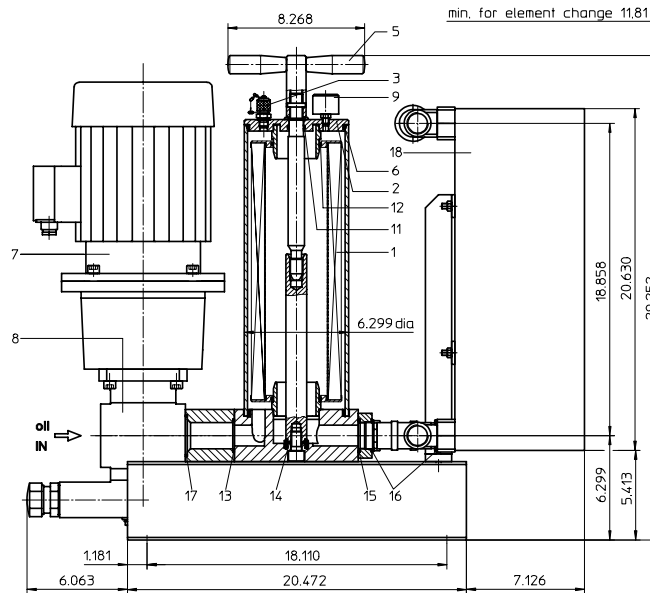
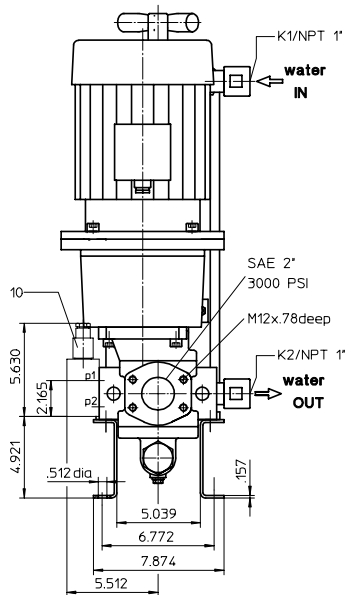
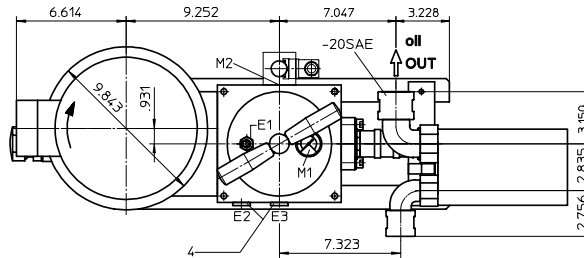

### 1. Type index:

#### 1.1. Filter unit: (ordering example)

**USP. 161. 6VG. 10. B. P. -. P18. D11. CP20. AE**

1	2	3	4	5	6	7	8	9	10	11
---	---	---	---	---	---	---	---	---	----	----

- 1 series:  
USP = filter unit, stationary with plate-exchanger
- 2 nominal size: 161
- 3 filter-material and filter-fineness:  
10 VG = 10 μm<sub>(c)</sub>, 6 VG = 7 μm<sub>(c)</sub>, 3 VG = 5 μm<sub>(c)</sub>, 1 VG = 4 μm<sub>(c)</sub> Interpor fleece (glass fiber)  
10 WVG = 10 μm<sub>(c)</sub>, 3 WVG = 5 μm<sub>(c)</sub> Watersorp-filter element
- 4 resistance of pressure difference for filter element:  
10 = Δp 145 PSI
- 5 filter element design:  
B = both sides open
- 6 sealing material:  
P = Nitrile (NBR)  
V = Viton (FPM), by agreement
- 7 filter element specification:  
- = standard  
VA = stainless steel
- 8 pump unit:  
P18 = pump unit 18, NG 160.100.6, adjustable pressure 87 PSI  
pump unit 18, NG 160.100.8, adjustable pressure 116 PSI
- 9 motor:  
D11 = B5/100LB/4.3.5.1800.460/790.D.60.1.-.- rotary current motor 460/790V, 60 Hz, approx. 1700 RPM, 3.5 HP, type of protection IP 54 v ≤ 464 SUS  
D08 = B5/112M/4.4.6.1800.460/790.D.60.1.-.- rotary current motor 460/790V, 60 Hz, approx. 1700 RPM, 4.6 HP, type of protection IP 54 v > 464 SUS  
v ≤ 695 SUS
- 10 plate-exchanger unit:  
CP20 = plate-exchanger unit CP20
- 11 clogging indicator at M2:  
- = without  
AE = AE30.2.5.P.-B electrical at p<sub>1</sub> and p<sub>2</sub>, 36 PSI see sheet-no. 1609  
AOR = AOR.2.5.P.- visual, 36 PSI see sheet-no. 1606  
AOC = AOC.2.5.P.- visual, 36 PSI see sheet-no. 1606

#### 1.2. Filter element: (ordering example)

**01NR. 630. 6VG. 10. B. P. -**

1	2	3	4	5	6	7
---	---	---	---	---	---	---

- 1 series:  
01NR. = standard-return-line filter element according to DIN 24550, T4
- 2 nominal size: 630
- 3 - 7 see type index-filter unit

Changes of measures and design are subject to alteration!



# FILTER UNIT, stationary with plate-exchanger

## Series USP 320 87 PSI

Sheet No.  
4024 B

### Assignment of connections and functions:

- E1: venting mini-measuring connection, MA.1.St see sheet-no. 1650
- E2: drainage of filter, dirt side
- E3: drainage of filter, clean side
- M1: measure connection in the housing cover, dirt side manometer 0-232 PSI
- M2: measure connection at filter housing
  - p<sub>1</sub> = dirt side
  - p<sub>2</sub> = clean side
- K1: cooling water IN
- K2: cooling water OUT

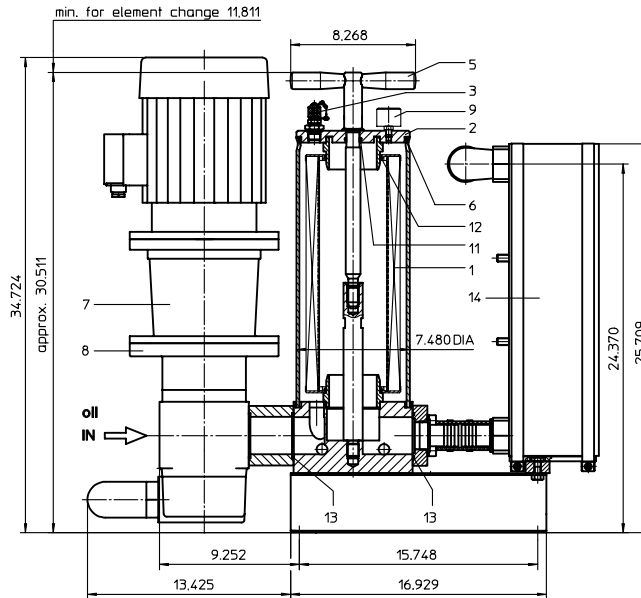
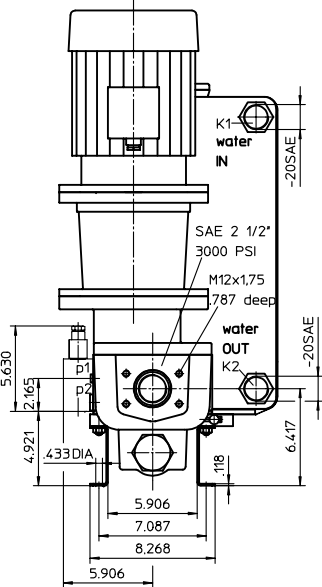
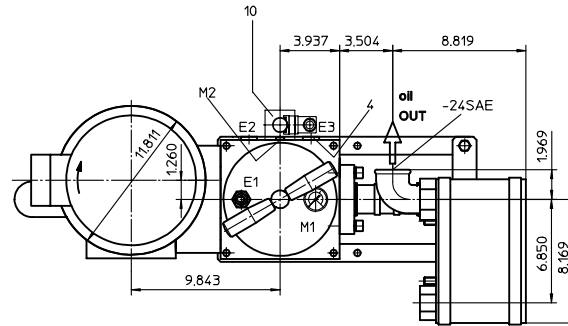

### 1. Type index:

#### 1.1. Filter unit: (ordering example)

**USP. 320. 6VG. 10. B. P. -. P07. D07. CP30. AE**

1	2	3	4	5	6	7	8	9	10	11
---	---	---	---	---	---	---	---	---	----	----

- 1 **series:**  
USP = filter unit, stationary with plate-exchanger
- 2 **nominal size:** 320
- 3 **filter-material and filter-finesness:**  
10 VG = 10  $\mu\text{m}_{(c)}$ , 6 VG = 7  $\mu\text{m}_{(c)}$ , 3 VG = 5  $\mu\text{m}_{(c)}$ , 1 VG = 4  $\mu\text{m}_{(c)}$ , Interpor fleece (glass fiber)  
10 WVG = 10  $\mu\text{m}_{(c)}$ , 3 WVG = 5  $\mu\text{m}_{(c)}$  Watersorp-filter element
- 4 **resistance of pressure difference for filter element:**  
10 =  $\Delta p$  145 PSI
- 5 **filter element design:**  
B = both sides open
- 6 **sealing material:**  
P = Nitrile (NBR)  
V = Viton (FPM), by agreement
- 7 **filter element specification:**  
- = standard  
VA = stainless steel
- 8 **pump unit:**  
P07 = pump unit 07, NG 320.200
- 9 **motor:**  
D07 = B5/132S/4.6.3.1800.460/790.D.60.1.-.- rotary current motor 460/790V, 60 Hz, approx. 1700 RPM, 6.3 HP, type of protection IP 5
- 10 **plate-exchanger unit:**  
CP30 = plate-exchanger unit CP30
- 11 **clogging indicator at M2:**  
- = without  
AE = AE30.2.5.P.-B electrical at p<sub>1</sub> and p<sub>2</sub>, 36 PSI, see sheet-no. 1609  
AOR = AOR.2.5.P.- visual, 36 PSI, see sheet-no. 1606  
AOC = AOC.2.5.P.- visual, 36 PSI, see sheet-no. 1606

#### 1.2. Filter element: (ordering example)

**01NR. 1000. 6VG. 10. B. P. -**

1	2	3	4	5	6	7
---	---	---	---	---	---	---

- 1 **series:**  
01NR. = standard-return-line filter element according to DIN 24550, T4
- 2 **nominal size:** 1000
- 3 - 7 see type index-filter unit

Changes of measures and design are subject to alteration!





## 2. Spare parts:

item	designation	qty.	dimension	article-no.
1	filter element	1	01NR. 1000	
2	housing cover	1	22694-3	313837
3	mini-measuring connection	1	MA.1.St	305453
4	screw plug	2	½ BSPP	304678
5	straining screw	1	31067-3	316893
6	O-ring	1	170 x 6	304799 (NBR)
7	E-motor D01	1	6.3 HP, 460/790 V	316821
8	pump unit P04	1	NG 320.200	316908
9	manometer (series)	1	1.57 dia	
10	clogging indicator	1	according to type index	
11	O-ring	1	22 x 3	304387 (NBR)
12	O-ring	2	90 x 4	306941 (NBR)
13	O-ring	3	69,45 x 3,53	305868 (NBR)
14	plate-exchanger unit	1	CP30	

## 3. Description:

The stationary filter unit with plate-exchanger is intended for oil maintenance and for oil cooling on hydraulic systems. The area of application comprises:

- secondary flow filtration in addition to the existing operating filter and the oil cooling
- secondary flow filtration without the action of the operating filter and the oil cooling
- filtration when filling the oil reservoir.

The filter unit must not be used to pump contaminated hydraulic fluids and is therefore designed without a switchover fitting to bypass the filter. The compact structural design with plate interlacing without pipe satisfies the prerequisites for small dimensions and high reliability.

The device is equipped with a gear pump driven by an e-motor. The flow conveyed by the geared pump is fed over a filter element to DIN 24550, T4, nominal size 1000 and is led afterwards over a plate cooler.

Depending on the customer's wishes, the filter fineness is either 4, 5, 7 or 10 µm<sup>(e)</sup>.

At the measuring point M1, the working pressure before the element is shown. The pollution of the element is indicated with the clogging indicator at the measuring point M2.

At a pressure difference > 36 PSI, the element is polluted and has to be removed with a new element.

The filter element can be changed without tools. After removing the straining screw and taking off the housing cover, the filter element is accessible and it can be exchanged. The filter elements are supplied complete with seals. Since it is not possible to clean the elements, the user must always keep an adequate supply of spare elements in stock.

To protect against overpressure, the filter unit is fitted with a safety valve, pressure setting approx. 87 PSI.

The cooling capacity is shown at the cooling capacity graph for the chosen field of application, depending on the input temperature, the streams of the medium and the type of medium. The cooling capacity graph is intended for the choice of application of the suitable filter unit with cooler. For the fields of application which are not shown in the cooling capacity graph, the capacity data have to be asked for at the manufacturer.

Stationary filter units can be operated without supervision if the electrical connection is fitted with an overload protection corresponding to the current consumption of the selected e-motor and the switch-off function of the e-motor of the electrical clogging indicator will disengaged at 36 PSI.

The line, venting and draining connections are identified according to their function. Drainage is necessary when cleaning the filter unit in connection with the change of filter element, and when setting the medium.

## 4. Symbols:

Filter unit with cooler  
without clogging indicator

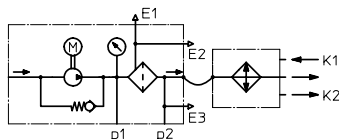

with electrical  
clogging indicator AE30



with visual  
clogging indicator  
AOR, AOC



## 5. Cooling capacity graph:

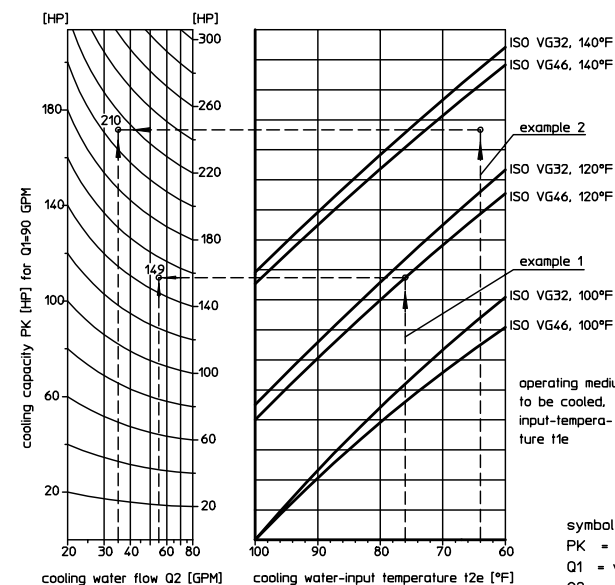

example 1, operating medium ISO VG46

t1e = 120°F, t2e = 76°F,  
Q1 = 90 GPM, Q2 = 55 GPM

cooling capacity PK from the graph = 149 HP

t1a = 120 -  $\frac{149 \times 12.4}{90}$  = 99.5°F

t2a = 76 +  $\frac{149 \times 5.1}{55}$  = 89.8°F

example 2, operating medium ISO VG32

t1e = 130°F, t2e = 64°F,  
Q1 = 90 GPM, Q2 = 35 GPM

cooling capacity PK from the graph = 210 HP  
(data linear interpolated)

t1a = 130 -  $\frac{210 \times 12.4}{90}$  = 101.1°F

t2a = 64 +  $\frac{210 \times 5.1}{35}$  = 94.6°F

symbol	units
PK = cooling capacity	HP
Q1 = volume flow-operating medium	GPM
Q2 = volume flow-cooling water	GPM
t1e = operating medium-input temperature	°F
t1a = operating medium-output temperature	°F
t2e = cooling water-input temperature	°F
t2a = cooling water-output temperature	°F

$$\text{operating medium-output temperature } t1a \text{ [°F]} \quad t1a = t1e - \frac{PK \times 12.4}{Q1}$$

$$\text{cooling water-output temperature } t2a \text{ [°F]} \quad t2a = t2e + \frac{PK \times 5.1}{Q2}$$

## 6. Technical data:

pump-volume flow :	90 GPM at 1700 RPM
E-motor:	6.3 HP, approx. 1700 RPM
rotary current:	460/790 V, 60 Hz
operating pressure:	max. 87 PSI
filter-fineness:	4, 5, 7 or 10 µm <sup>(e)</sup>
weight:	approx. 341 lbs.
operating medium:	hydraulic oil based on mineral oil from 46 up to 464 SUS, other media on request

Classified under the Pressure Vessel Directive 97/23/EC for mineral oil (fluid group 2), Article 3, Para. 3.  
Classified under ATEX Directive 94/9/EC according to specific application (see questionnaire sheet-no. 34279-4).

## 7. Test methods:

Filter elements are tested according to the following ISO standards:

ISO 2941	Verification of collapse/burst resistance
ISO 2942	Verification of fabrication integrity
ISO 2943	Verification of material compatibility with fluids
ISO 3723	Method for end load test
ISO 3724	Verification of flow fatigue characteristics
ISO 3968	Evaluation of pressure drop versus flow characteristics
ISO 16889	Multi-pass method for evaluating filtration performance