

OVERALL DIMENSIONS
Eyes with internal thread (MW)

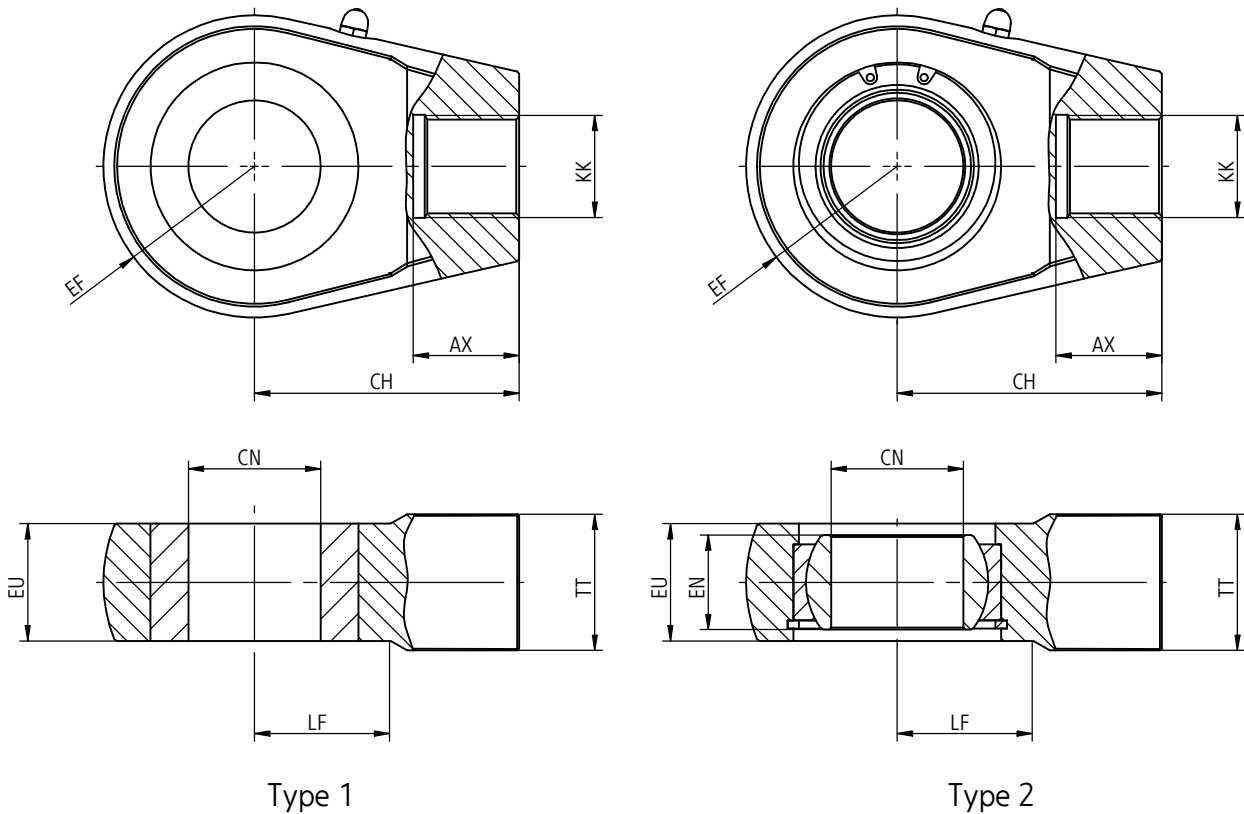

cylinder diameter	25	32	40	50	63	80	100	125	140	160
AX	16	18	22	22	28	34	40	50	56	60
CH	36	44	50	56	70	88	105	135	150	170
CN	16	20	25	30	35	40	50	60	70	80
EN	14	16	20	22	25	28	35	44	49	55
EF	21	25	30	36	40	50	60	73	84	97
EU	14	20	24	26	31	32	40	55	60	65
KK	M12x1,5	M16x1,5	M16x1,5	M22x1,5	M27x2	M33x2	M42x2	M48x2	M56x2	M64x2
LF	16	22	-	28	36	45	56	70	80	90
TT	19	24	24	30	36	46	60	75	85	95

OVERALL DIMENSIONS
Eyes with external thread (MZ)

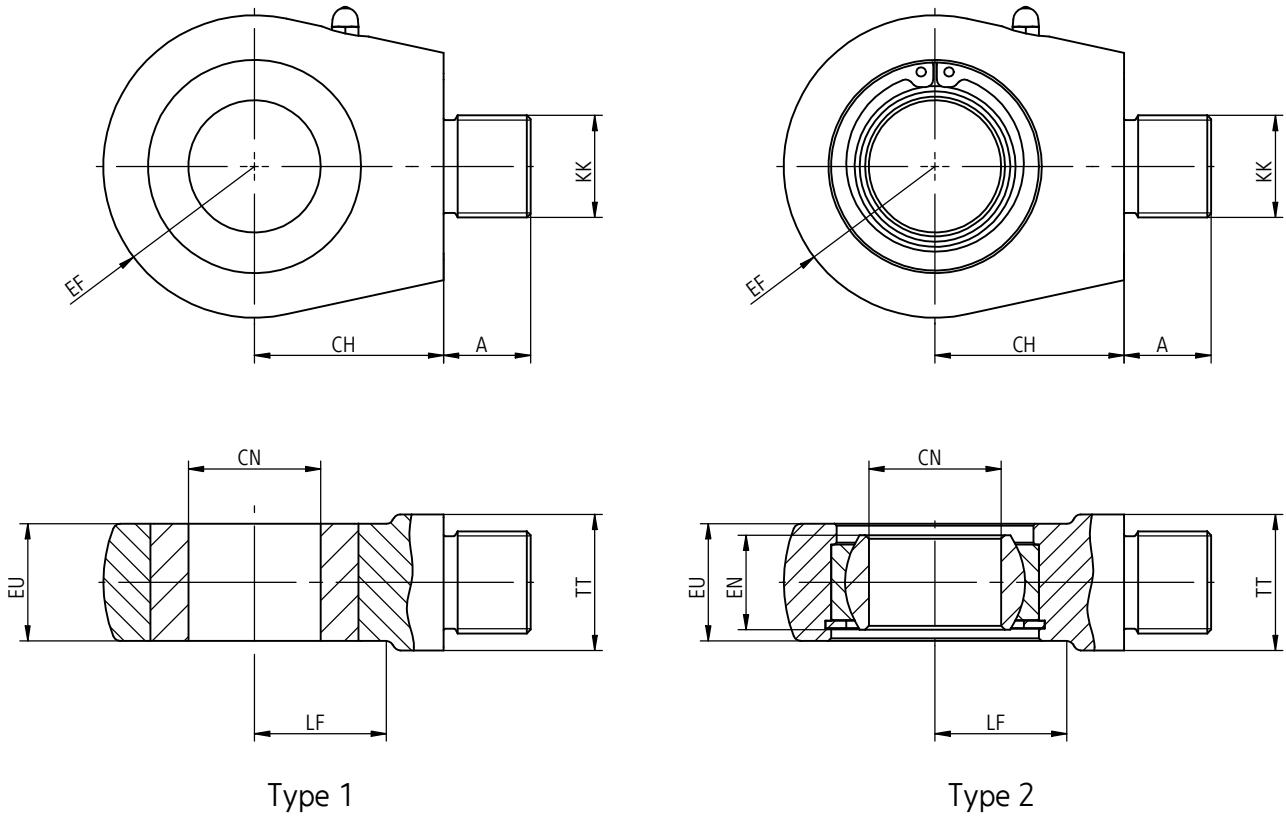

cylinder diameter	40	50	63	80	100	125	140	160
A	18	20	22	30	36	45	50	56
CH	36	40	50	63	75	95	105	120
CN	25	30	35	40	50	60	70	80
EN	20	22	25	28	35	44	49	55
EF	30	36	40	50	60	73	84	97
EU	24	26	31	32	40	55	60	65
KK	M16x1,5	M22x1,5	M27x2	M33x2	M42x2	M48x2	M56x2	M64x2
LF	-	28	36	45	56	70	80	90
TT	24	30	36	46	60	75	85	95

HOW TO ORDER

UU	/	+	+	*
----	---	---	---	---

Cylinder eye

Type
 swivel bearing = 1
 spherical bearing = 2

Cylinder diameter
 against a table

Series number
 02 = 02
 (00-09) installation and connection dimension unchanged

Mounting
 External metric thread = MZ
 Internal metric thread = MW

Futher requirements to be added in text (to agree with manufacturer)

Coding example:

UU1/80-02-MW

For special requirements, please, contact the manufacturer.

PONAR Wadowice S.A.
ul. Wojska Polskiego 29
34-100 Wadowice
tel. +48 33 488 21 00
fax. +48 33 488 21 03
www.ponar-wadowice.pl

