

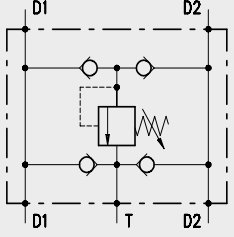

Pressure relief valves

Hydraulic diagram	Type	Description	Maximum flow up to		Maximum pressure		Page
			l/min	US gpm	bar	psi	
	VAA/RU/DL	Antishock valve with anti cavitation and single pressure adjustment. Differential control, poppet type line mounting	180	48	350	5100	99

Operation

Antishock valve with anti cavitation and single pressure adjustment. Differential control, poppet type line mounting.
 The valve allows pressure relief on delivery pipes to engines and cylinders. When the actuator is braking, two check valves allow for anti cavitation on delivery side.
 Actuator close mount is recommended to assure a more rapid valve action.

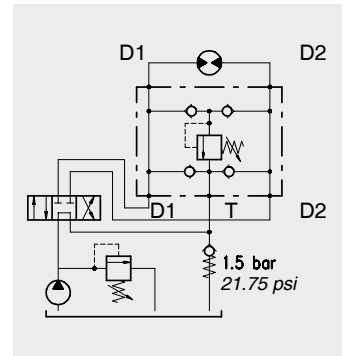

Performance

Body Valves

Type	Max. flow		Max. pres.		Application range with standard spring*	Hysteresis	Oil leaks from P to T	Weight		Cartridge
	l/min	US gpm	bar	psi						
VAA/RU/DL 38	35	9.2	alum. body 210 steel body 300	alum. body 3050 steel body 5100	5÷210 bar - 72.5÷3050 psi (test setting 150 bar - 2200 psi at 5 l/min. - 1.32 US gpm) 50÷350 bar - 725÷5100 psi (test setting 250 bar - 3600 psi at 5 l/min. - 1.32 US gpm)	85% of the setting value for flow capacity 1 l/min. -0.26 US gpm-	disregardable	alum. body 1,18	alum. body 2.60	VMPD 38
VAA/RU/DL 12	60	16			5÷210 bar - 72.5÷3050 psi (test setting 150 bar - 2200 psi at 5 l/min. - 1.32 US gpm) 50÷250 bar - 725÷300 psi- (test setting 250 bar - 3600 psi at 5 l/min. - 1.32 US gpm)			alum. body 1,15	alum. body 2.53	
VAA/RU/DL 34 (100)	(34) 120 (100) 180	(34) 32 (100) 48			5÷210 bar - 72.5÷3050 psi (test setting 150 bar - 2200 psi at 5 l/min. - 1.32 US gpm) 50÷350 bar - 725÷5100 psi (test setting 250 bar - 3600 psi at 5 l/min. - 1.32 US gpm)			alum. body 2,32 steel body 4,59	alum. body 5.11 steel body 10.12	VMPD 38
				-34- alum. body 2,32 steel body 4,59	-34- alum. body 5.11 steel body 10.12					
					-100- alum. body 3,32 steel body 6,37			-100- alum. body 7.32 steel body 14.04		

*To perform setting of the valve see the pressure drop/ flow diagram.

Type VAA/RU/DL 38

Antishock valve with anti cavitation and single pressure adjustment. Differential control, poppet type line mounting

Dimensions and hydraulic circuit

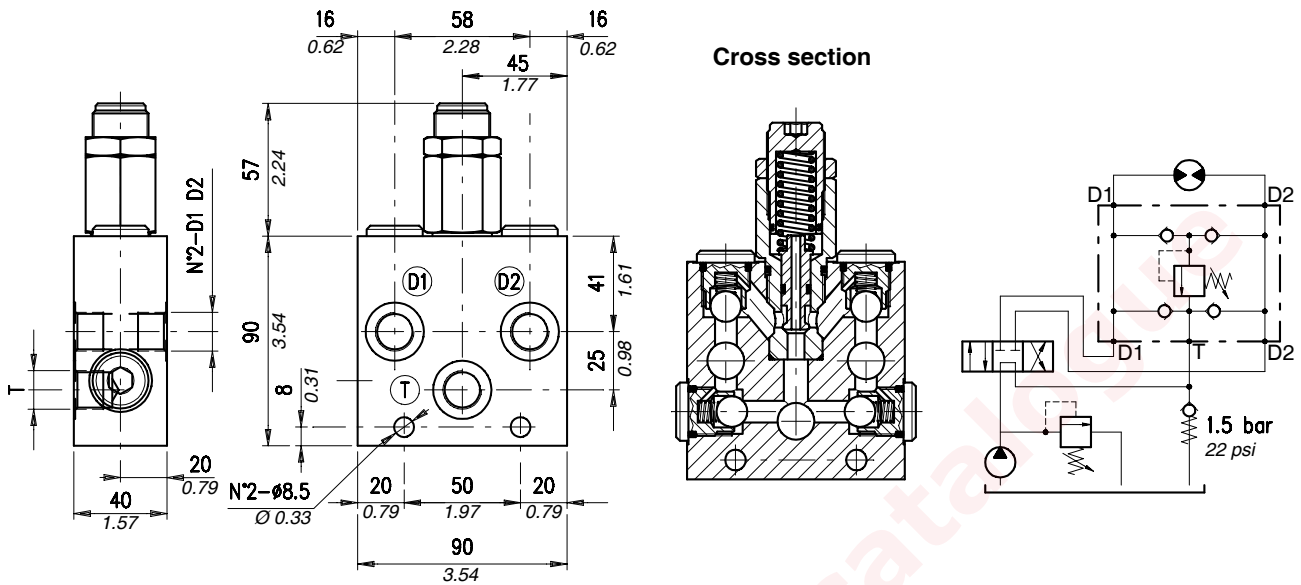

D1	D2	T
G 3/8	G 3/8	G 3/8

Rating diagrams

Typical pressure drop vs. flow characteristic

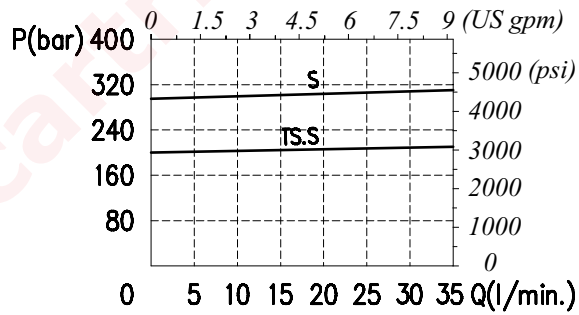

Order code

VAA /RU /DL 38/ □□ . S / □□

Pressure settings

TS) 5÷210 bar (72.5÷3050 psi)
TR) 50÷350 bar (725÷5100 psi)

Body material

_ Aluminium
ac Steel

Dimensions and hydraulic circuit

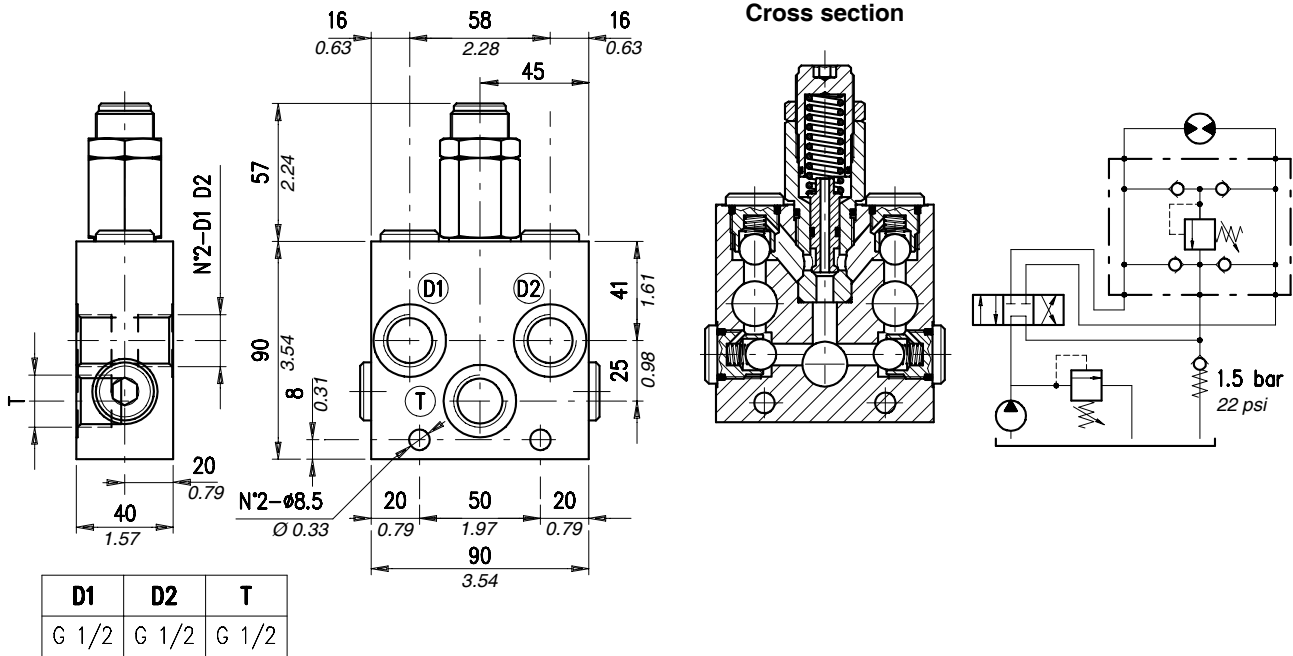

Rating diagrams

Typical pressure drop vs. flow characteristic

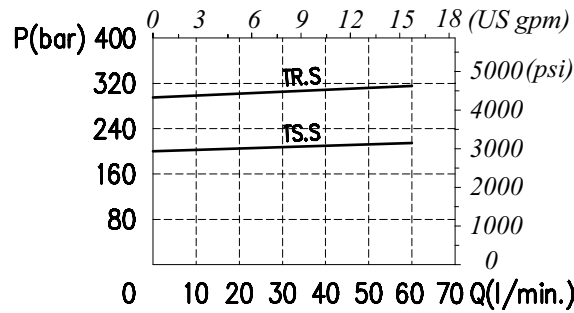

Order code

VAA /RU /DL 12/ □□ . S / □□

Pressure settings

Body material

TS 5÷210 bar (72.5÷3050 psi)
TR 50÷350 bar (725÷5100 psi)

_ Aluminium
ac Steel

Type VAA/RU/DL 34 (100)

Antishock valve with anti cavitation and single pressure adjustment.
Differential control, poppet type line mounting

Dimensions and hydraulic circuit

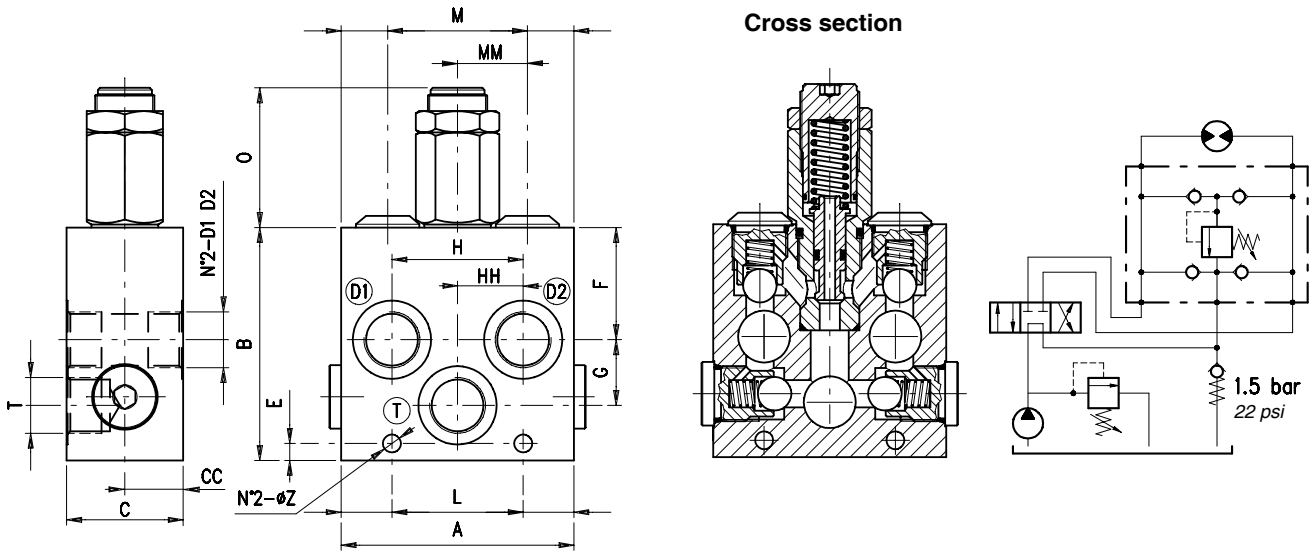

VAA/RU/DL	A	B	C	CC	E	F	G	H	HH		M	MM	O	D1	D2	T	Z	OR
34	110 - 4.33	110 - 4.33	55 - 2.16	27.5 - 1.08	8 - 0.31	53 - 2.08	31 - 1.22	62 - 2.44	31 - 1.22	62 - 2.44	66 - 2.60	33 - 1.30	66 - 2.60	G 3/4	G 3/4	G 3/4	8.5 - 0.33	3093
100	140 - 5.51	140 - 5.51	60 - 2.36	30 - 1.18	11 - 0.43	65 - 2.56	37 - 1.46	86 - 3.38	43 - 1.69	76 - 2.99	86 - 3.38	43 - 1.69	-	G 1	G 1	G 1	10.5 - 0.41	3093

Dimensions are in mm - in

Rating diagrams

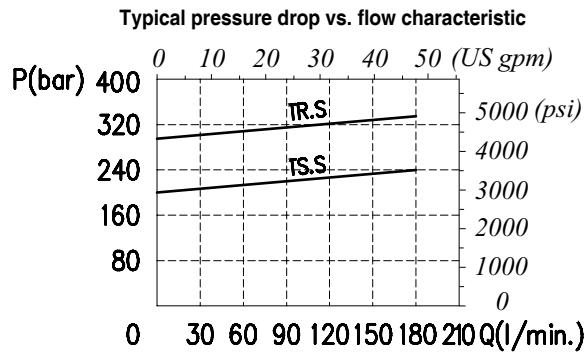

Order code

VAA /RU /DL □□ / □□ . S / □□

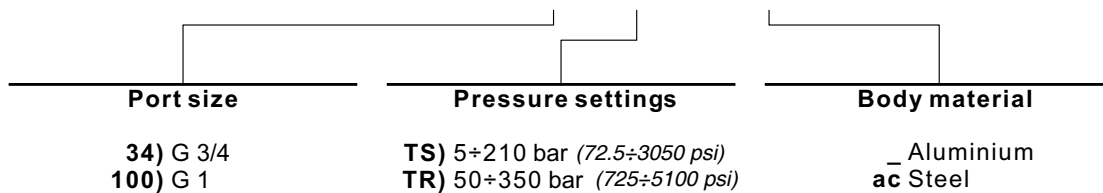

Description and operation

This chapter show main adjusting devices for the valves listed in this catalog.
These regulations are used to adjust flow rate between inlet and working ports.

Performance

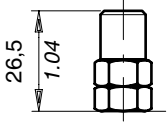
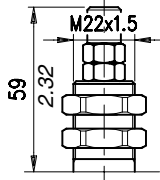
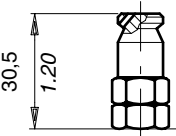
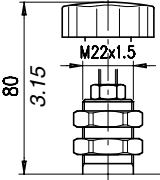
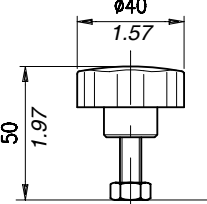
	<p>Screw "S"</p>		<p>Panel mount "P"</p>
	<p>Copped adjustment "W"</p>		<p>Panel mount+handknob "PV"</p>
	<p>Handknob "V"</p>		

Dimensions

Material	Max. pressure	
	bar	psi
Alluminium	210	3050
Steel	350	5100

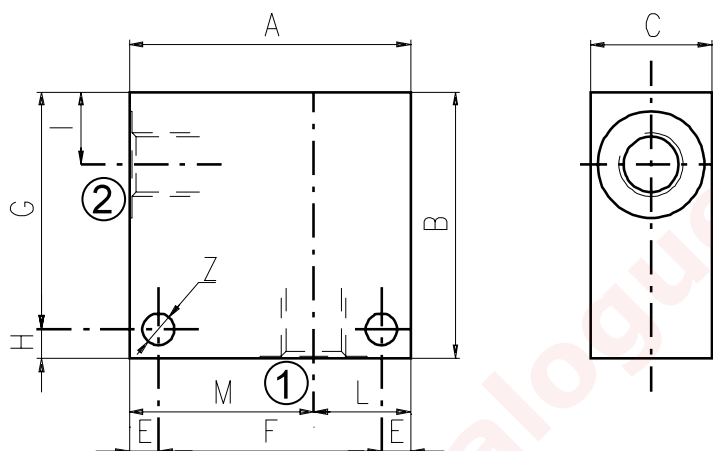

Cavità	Attacchi		A	B	C	E	F	G	H	I	L	M	Z
SAE 8/2	G 1/2	mm	70	65	35	7	56	53	12	14,5	35	35	6,5
		in	2.75	2.56	1.38	0.27	2.20	2.09	0.47	0.57	1.38	1.38	0.25
	G 1/4	mm	50	50	30	6	38	44	6	14,8	20	30	6,5
		in	1.97	1.97	1.18	0.24	1.50	1.73	0.24	0.58	0.79	1.18	0.25
	G 3/8	mm	50	50	30	6	38	44	6	14,8	20	30	6,5
		in	1.97	1.97	1.18	0.24	1.50	1.73	0.24	0.58	0.79	1.18	0.25
	SAE6	mm	50	50	30	6	38	44	6	14,8	20	30	6,5
		in	1.97	1.97	1.18	0.24	1.50	1.73	0.24	0.58	0.79	1.18	0.25
SAE 10/2	G 1/4	mm	60	60	35	6	48	54	6	18,8	25	35	6,5
		in	2.36	2.36	1.38	0.24	1.89	2.12	0.24	0.74	0.98	1.38	0.25
	G 3/8	mm	60	60	35	6	48	54	6	18,8	25	35	6,5
		in	2.36	2.36	1.38	0.24	1.89	2.12	0.24	0.74	0.98	1.38	0.25
	G 1/2	mm	60	60	35	6	48	54	6	18,8	25	35	6,5
		in	2.36	2.36	1.38	0.24	1.89	2.12	0.24	0.74	0.98	1.38	0.25
	SAE8	mm	60	70	35	6	48	64	6	18,8	25	35	6,5
		in	2.36	2.75	1.38	0.24	1.89	2.52	0.24	0.74	0.98	1.38	0.25
	SAE10	mm	70	70	35	6	58	64	6	18,5	35	35	6,5
		in	2.75	2.75	1.38	0.24	2.28	2.52	0.24	0.73	1.38	1.38	0.25
	SAE12	mm	70	70	40	8	54	62	8	22	30	40	8,5
		in	2.75	2.75	1.57	0.31	2.12	2.44	0.31	0.87	1.18	1.57	0.33
SAE 12/2	G 1/2	mm	70	80	40	8	54	72	8	25	30	40	8,5
		in	2.75	3.15	1.57	0.31	2.12	2.83	0.31	0.98	1.18	1.57	0.33
	G 3/4	mm	70	90	40	8	54	82	8	25	30	40	8,5
		in	2.75	3.54	1.57	0.31	2.12	3.23	0.31	0.98	1.18	1.57	0.33
	SAE10	mm	70	85	40	8	54	77	8	25	30	40	8,5
		in	2.75	3.35	1.57	0.31	2.12	3.03	0.31	0.98	1.18	1.57	0.33
	SAE12	mm	70	85	40	8	54	77	8	25	30	40	8,5
		in	2.75	3.35	1.57	0.31	2.12	3.03	0.31	0.98	1.18	1.57	0.33

Cavity	Ports	A	B	C	E	F	G	H	I	L	M	Z	
SAE 16/2	G 1/2	mm	80	90	50	10	60	80	10	25	35	45	10,5
		in	3.15	3.54	1.97	0.39	2.36	3.15	0.39	0.98	1.38	1.77	0.41
	G 3/4	mm	80	90	50	10	60	80	10	25	35	45	10,5
		in	3.15	3.54	1.97	0.39	2.36	3.15	0.39	0.98	1.38	1.77	0.41
	G 1	mm	85	100	60	10	65	90	10	23,5	40	45	10,5
		in	3.35	3.94	2.36	0.39	2.56	3.54	0.39	0.92	1.57	1.77	0.41
	SAE12	mm	80	90	50	10	60	80	10	25	35	45	10,5
		in	3.15	3.54	1.97	0.39	2.36	3.15	0.39	0.98	1.38	1.77	0.41
	SAE16	mm	80	100	50	10	60	90	10	25	35	45	10,5
		in	3.15	3.94	1.97	0.39	2.36	3.54	0.39	0.98	1.38	1.77	0.41

Order code

3/CC /- □ □ /20/□- □-1

Cavity	Ports	Materials
08	B) G 1/4	1) Aluminium
10	C) G 3/8	2) Steel
12	D) G 1/2	
16	E) G 3/4	
	F) G 1	

2, 3 and 4 way Valves Bodies

3 WAY BODIES

Dimensions

Material	Max. pressure	
	bar	psi
Alluminium	210	3050
Steel	350	5100

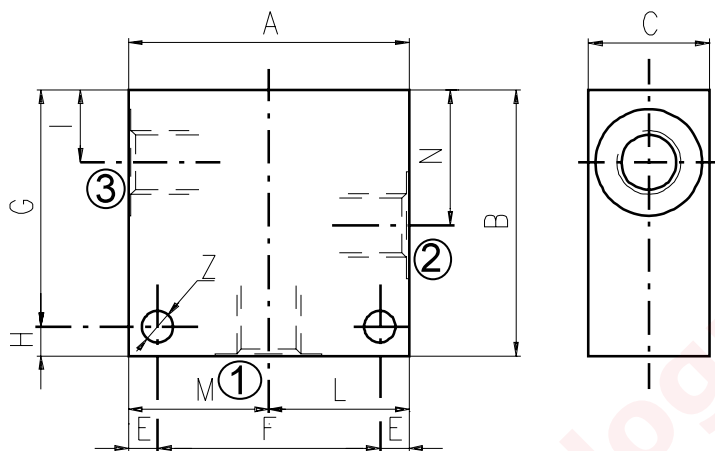

Cavity	Ports		A	B	C	E	F	G	H	I	L	M	N	Z
SAE 8/3	G 1/4	mm	60	60	30	7	46	48	12	14,8	30	30	29,1	6,5
		in	2.36	2.36	1.18	0.27	1.81	1.89	0.47	0.58	1.18	1.18	1.14	0.25
	G 3/8	mm	60	60	30	7	46	48	12	14,5	30	30	29,1	6,5
		in	2.36	2.36	1.18	0.27	1.81	1.89	0.47	0.57	1.18	1.18	1.14	0.25
	G 1/2	mm	70	65	35	7	56	53	12	14,5	35	35	29,1	6,5
		in	2.75	2.56	1.38	0.27	2.20	2.09	0.47	0.57	1.38	1.38	1.14	0.25
	SAE6	mm	60	60	30	7	46	48	12	14,5	30	30	29,1	6,5
		in	2.36	2.36	1.18	0.27	1.81	1.89	0.47	0.57	1.18	1.18	1.14	0.25
SAE 10/3	G 1/4	mm	60	65	35	6	48	59	6	18	30	30	34,5	7
		in	2.36	2.56	1.38	0.24	1.89	2.32	0.24	0.70	1.18	1.18	1.36	0.27
	G 3/8	mm	60	65	35	6	48	59	6	18,8	30	30	34,5	7
		in	2.36	2.56	1.38	0.24	1.89	2.32	0.24	0.74	1.18	1.18	1.36	0.27
	G 1/2	mm	65	70	35	6	53	64	6	18,8	32,5	32,5	34,5	7
		in	2.56	2.75	1.38	0.24	2.09	2.52	0.24	0.74	1.28	1.28	1.36	0.27
	SAE6	mm	65	70	35	6	53	64	6	18,8	32,5	32,5	34,5	7
		in	2.56	2.75	1.38	0.24	2.09	2.52	0.24	0.74	1.28	1.28	1.36	0.27
	SAE8	mm	65	70	35	6	53	64	6	18,8	32,5	32,5	34,5	7
		in	2.56	2.75	1.38	0.24	2.09	2.52	0.24	0.74	1.28	1.28	1.36	0.27
SAE 12/3	G 1/2	mm	70	100	40	8	54	92	8	25	35	35	53,5	8,5
		in	2.75	3.94	1.57	0.31	2.12	3.6	0.31	0.98	1.38	1.38	2.10	0.33
	G 3/4	mm	90	100	50	10	70	90	10	25,1	45	45	53,5	10,5
		in	3.54	3.94	1.97	0.39	2.75	3.54	0.39	0.99	1.77	1.77	2.11	0.41
	SAE10	mm	80	100	40	8	64	92	8	25	40	40	53,5	8,5
		in	3.15	3.94	1.57	0.31	2.52	3.6	0.31	0.98	1.57	1.57	2.11	0.33
	SAE12	mm	80	100	45	8	64	92	8	25	40	40	53,5	8,5
		in	3.15	3.94	1.57	0.31	2.52	3.6	0.31	0.98	1.57	1.57	2.11	0.33
SAE 16/3	G 3/4	mm	90	100	50	10	70	90	10	25,1	45	45	53,5	10,5
		in	3.54	3.94	1.97	0.39	2.75	3.54	0.39	0.99	1.77	1.77	2.11	0.41
	SAE12	mm	90	105	50	10	70	95	10	25,1	45	45	53,5	10,5
		in	3.54	4.13	1.97	0.39	2.75	3.74	0.39	0.99	1.77	1.77	2.11	0.41
	SAE16	mm	90	105	50	10	70	95	10	25,1	45	45	53,5	10,5
		in	3.54	4.13	1.97	0.39	2.75	3.74	0.39	0.99	1.77	1.77	2.11	0.41

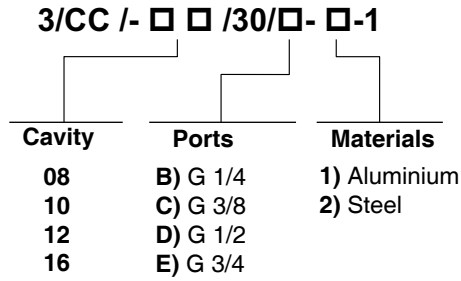

see SAE cartridges catalogue

2, 3 and 4 way Valves Bodies

4 WAY BODIES

Dimensions

Material	Max. pressure	
	bar	psi
Alluminium	210	3050
Steel	350	5100

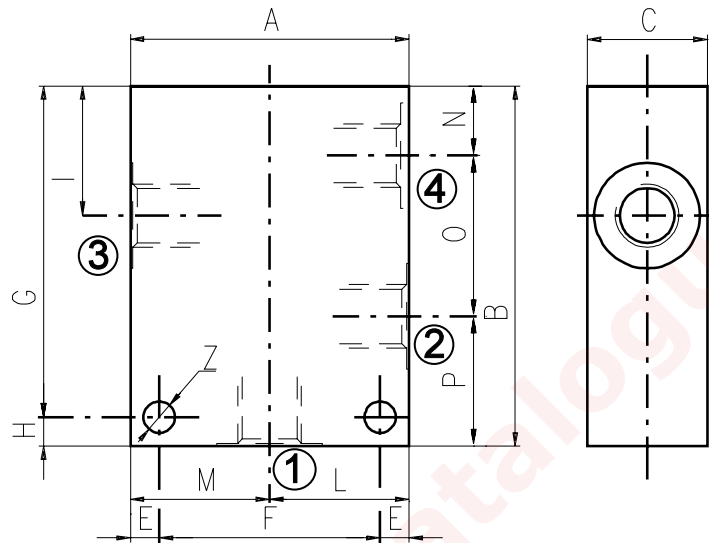

Cavity	Ports	A	B	C	E	F	G	H	I	L	M	N	O	P	Z	
SAE 8/4	G 1/4	mm	60	75	30	7	46	63	12	29,1	30	30	14,8	29,1	31,1	6,5
		in	2.36	2.95	1.18	0.27	1.81	2.48	0.47	1.14	1.18	1.18	0.58	1.14	1.22	0.25
	SAE6	mm	60	75	30	7	46	63	12	29,1	30	30	14,8	29,1	31,1	6,5
		in	2.36	2.95	1.18	0.27	1.81	2.48	0.47	1.14	1.18	1.18	0.58	1.14	1.22	0.25
SAE 10/4	G 3/8	mm	60	85	35	6	48	79	6	34,5	30	30	18,8	31,7	34,5	7
		in	2.36	3.35	1.38	0.24	1.89	3.11	0.24	1.36	1.18	1.18	0.74	1.25	1.36	0.27
	G 1/2	mm	70	85	35	6	58	79	6	34,5	35	35	18,8	31,7	34,5	7
		in	2.75	3.35	1.38	0.24	2.28	3.11	0.24	1.36	1.38	1.38	0.74	1.25	1.36	0.27
	SAE6	mm	60	85	35	6	48	79	6	34,5	30	30	18,8	31,7	34,5	7
		in	2.45	3.35	1.38	0.24	1.89	3.11	0.24	1.36	1.18	1.18	0.74	1.25	1.36	0.27
	SAE8	mm	70	85	35	6	58	79	6	34,5	35	35	18,8	31,7	34,5	7
		in	2.75	3.35	1.38	0.24	2.28	3.11	0.24	1.36	1.38	1.38	0.74	1.25	1.36	0.27
SAE 12/4	G 1/2	mm	80	115	40	8	64	107	8	44	40	40	22	44,5	48,5	8,5
		in	3.15	4.53	1.57	0.31	2.52	4.21	0.31	1.73	1.57	1.57	0.87	1.75	1.9	0.33
	SAE10	mm	80	115	40	8	64	107	8	44	40	40	22	44,5	48,5	8,5
		in	3.15	4.53	1.57	0.31	2.52	4.21	0.31	1.73	1.57	1.57	0.87	1.75	1.9	0.33
SAE 16/4	G 3/4	mm	100	130	50	10	80	120	10	53,5	50	50	25,1	56,9	48	10,5
		in	3.94	5.12	1.97	0.39	3.15	4.72	0.39	2.11	1.97	1.97	0.99	2.24	1.89	0.41

3/CC /- □ □ /40/□- □-1

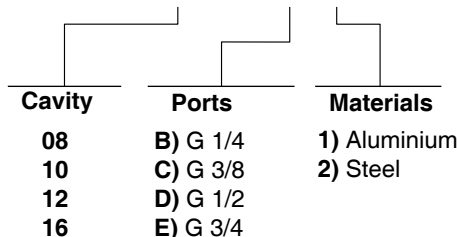

How to order valves with body

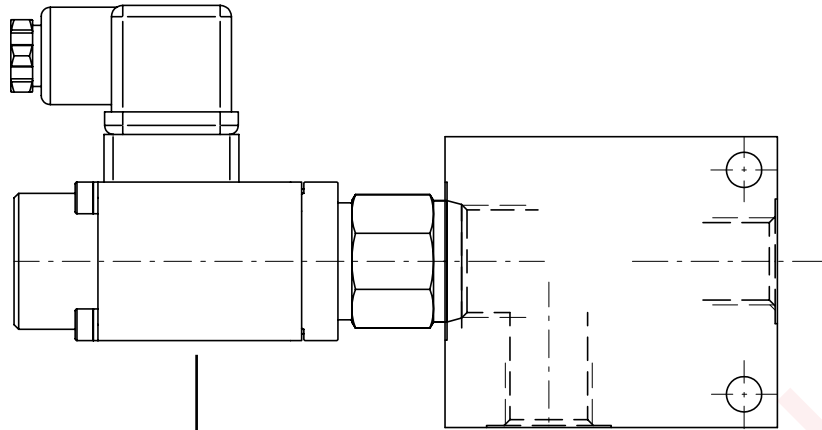

CARTRIDGE CODE

MP-10-Y/0-4-1V/

BILLET CODE

C- 1-1

Cavity	Ports	Materials
08	B) G 1/4	1) Aluminium
10	C) G 3/8	
12	D) G 1/2	
16	E) G 3/4	
	F) G 1	
	J) SAE 6	2) Steel
	K) SAE 8	
	L) SAE 10	
	M) SAE 12	
	N) SAE 16	

Dimensions

VARIATION "A": the dimensions with "★" are related to the variation "A". Features of variation "A" are required only if noted on specific product catalogue page.

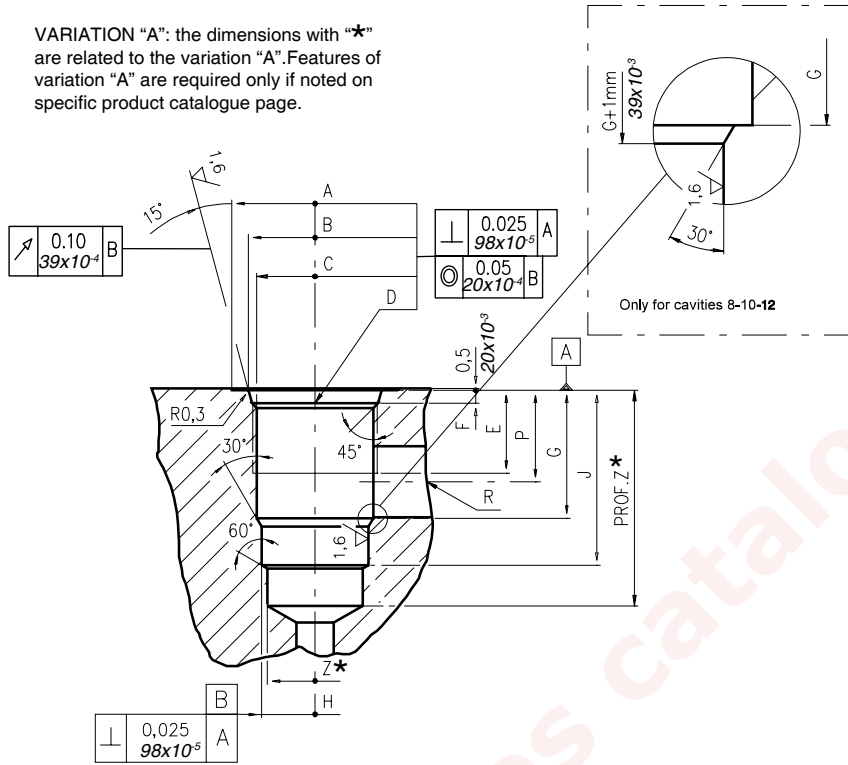

\		A	B ±0,05	C ±0,05	D	E	F	G	H ±0,02	J	K ±0,02	L	M ±0,02	N	P	R øMAX	S øMAX	T øMAX	U	V øMAX	X øMAX	Z ★ øMIN	Prof.Z MIN★
		08/2	mm	27	20,66	17,42	3/4-16 UNF	12,50	2,50	18,20	12,72	29,50	-	-	-	-	14,00	8,00	-	-	-	-	-
	in	1.06	0.81	0.68		0.49	0.10	0.72	0.50	1.16					0.55	0.31						0.47	1.53
10/2	mm	30	24,00	20,62	7/8-14 UNF	16,00	2,80	24,00	15,90	33,50	-	-	-	-	18,30	11,00	-	-	-	-	-	14,50	40
	in	1.18	0.94	0.81		0.63	0.11	0.94	0.62	1.32					0.72	0.43						0.57	1.57
12/2	mm	38	29,23	24,73	1 1/16-12 UNF	19,00	3,50	34,15	22,25	46,80	-	-	-	-	24,50	19,00	-	-	-	-	-	21,50	60
	in	1.50	1.15	0.97		0.75	0.14	1.34	0.87	1.84					0.96	0.75						0.85	2.36
16/2	mm	45	35,58	31,34	1 5/16-12 UNF	22,00	3,50	34,00	28,62	47,00	-	-	-	-	24,50	19,00	-	-	-	-	-	25,50	70
	in	1.77	1.40	1.23		0.87	0.14	1.34	1.13	1.85					0.96	0.75						1.00	2.75

Rougher tool

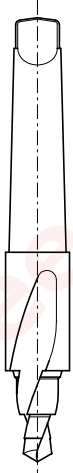

Cavity	Code number
08/2	3UT00053190
10/2	3UT00056610
12/2	3UT00054090
16/2	3UT00054510

Finisher tool

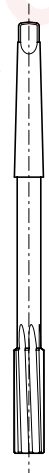

Cavity	Code number
08/2	3UT06A1270N
10/2	3UT00054580
12/2	3UT00054670
16/2	3UT00054520

Tap

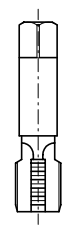

Cavity	Code number
08/2	3UT03416UNF
10/2	3UT07814UNF
12/2	3UT0111612UN
16/2	3UT0151612UN

Cavity plugs

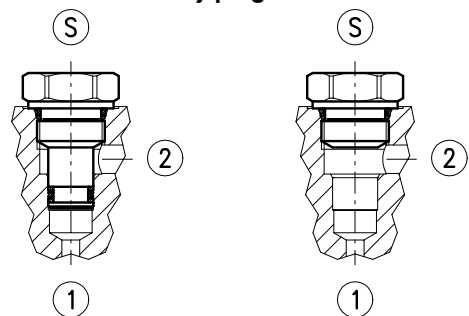

Cavity	Code number	①	②	Ⓢ
08/2	3XTP3533700	X	X	X
	4TP5531500	0	0	X
10/2	3XTP3544200	X	X	X
	3XTP1542300	0	0	X
12/2	3XTP3555400	X	X	X
	3XTP1552900	0	0	X
16/2	3XTP3575500	X	X	X
	3XTP1572900	0	0	X

X=Closed 0=Open

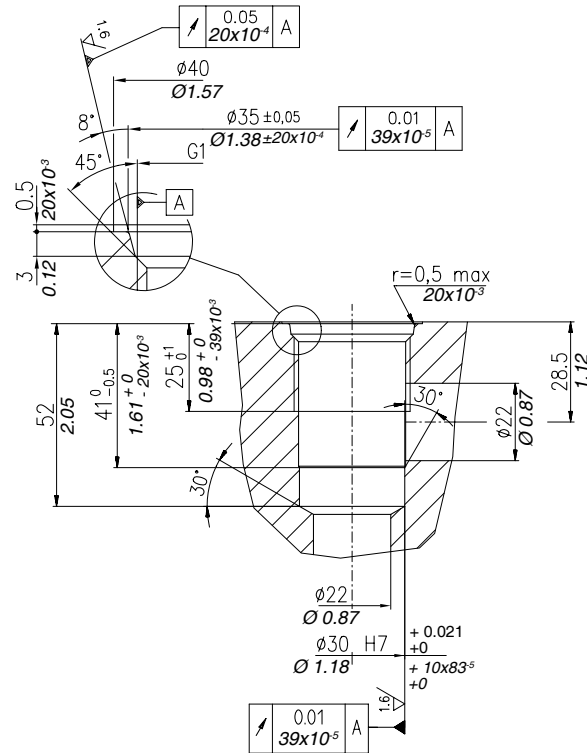

Rougher tool
Cod.3UT00050870A

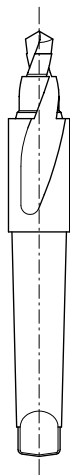

Finisher tool
Cod.3UTO6A3000N



Tap
Cod.3UT09A10F11G



Dimensions

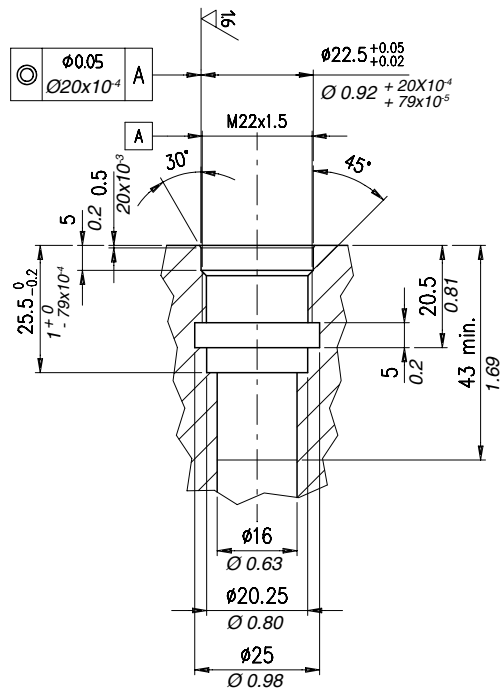

Rougher tool
Code 3UT00054660

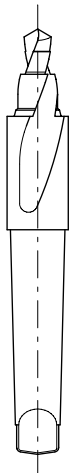

Finisher tool
Code 3UT00055530



Tap
Code 3UT08A22F150



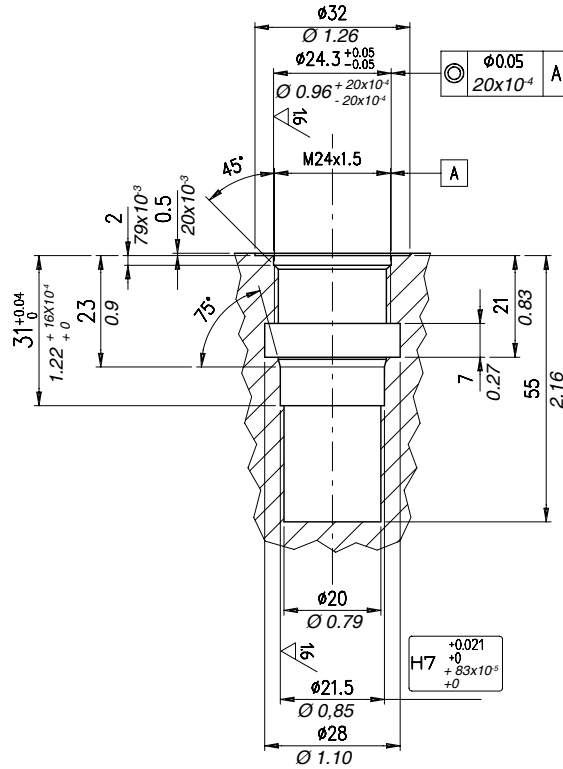

Rougher tool

Code 3UT00052210

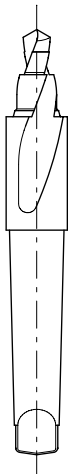

Finisher tool

Code 3UT00055030

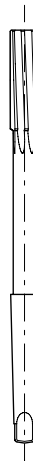

Tap

Code 3UT08A24F150



Dimensions

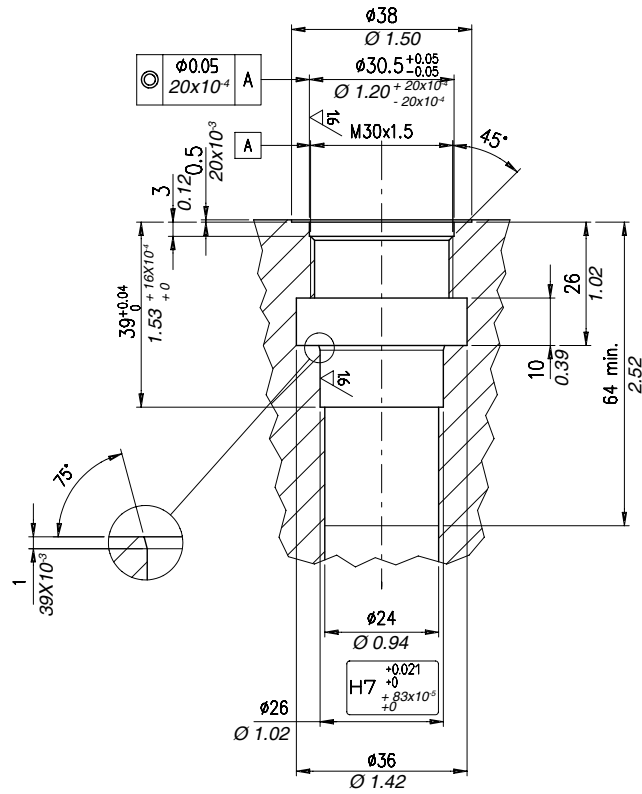

Rougher tool
Code 3UT00052200

Finisher tool
Code 3UT06A2600P

Tap
Code 3UT08A30F150

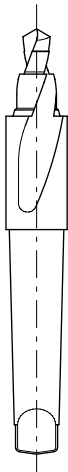

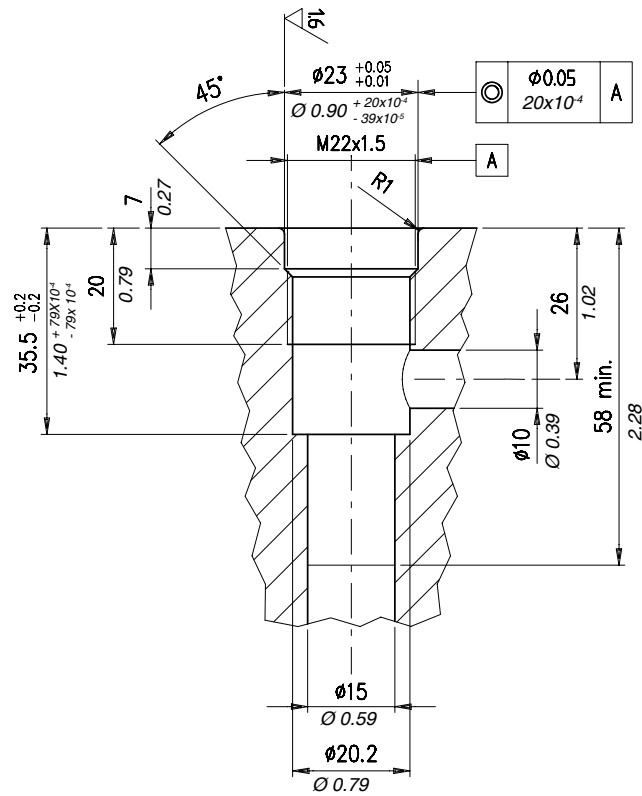

Rougher tool
Code 3UT00055540

Finisher tool
Code 3UT06A2300N

Tap
Code 3UT08A22F150

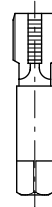
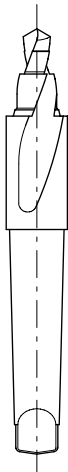

Dimensions

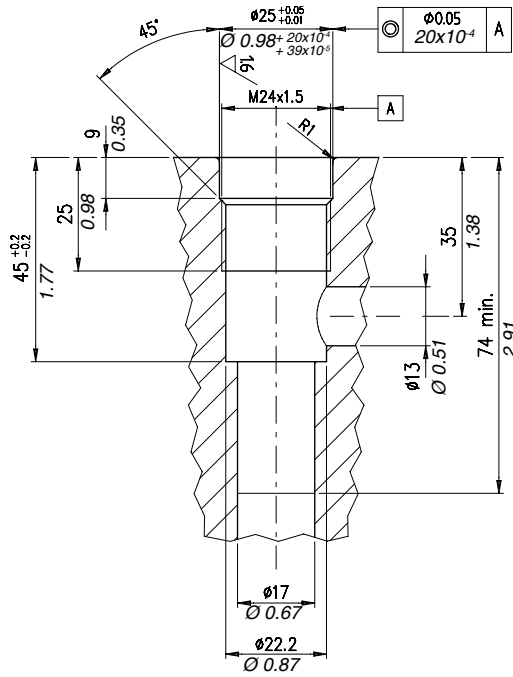

Rougher tool

Code 3UT00055550

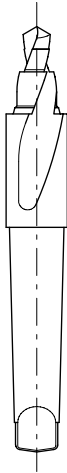

Finisher tool

Code 3UT06A2500N



Tap

Code 3UT08A24F150



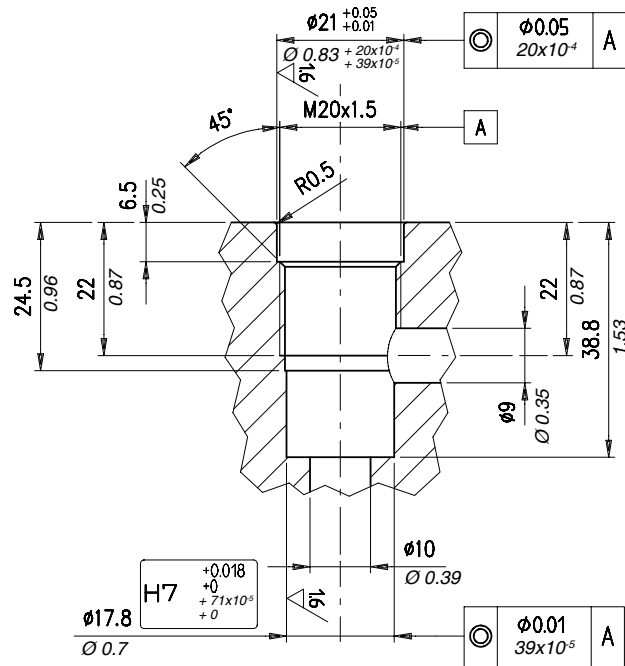

Rougher tool
Code 3UT00050050

Finisher tool
Code 3UT00055040

Tap
Code 3UT08A20F150

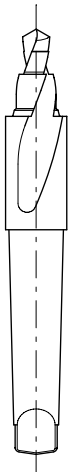

Dimensions

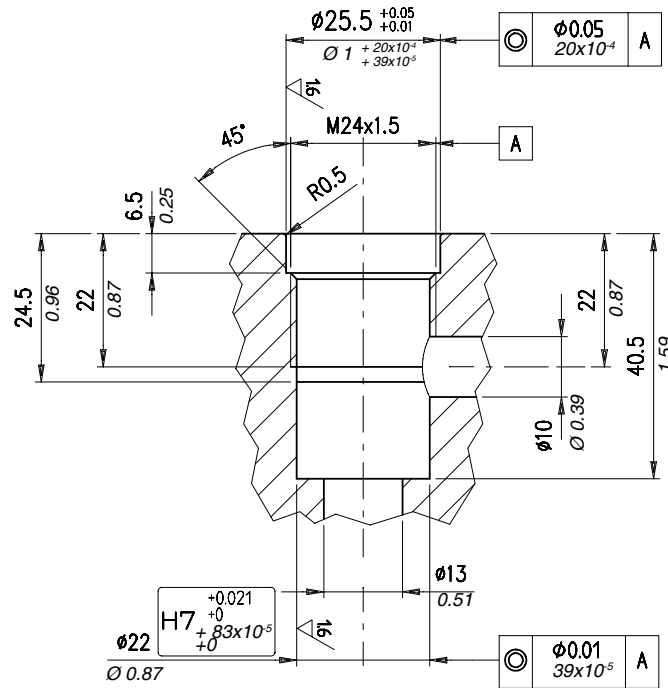

Rougher tool
Code 3UT00050070

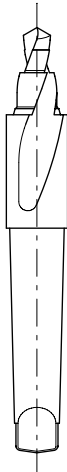

Finisher tool
Code 3UT06A22000P



Tap
Code 3UT08A24F150

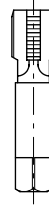

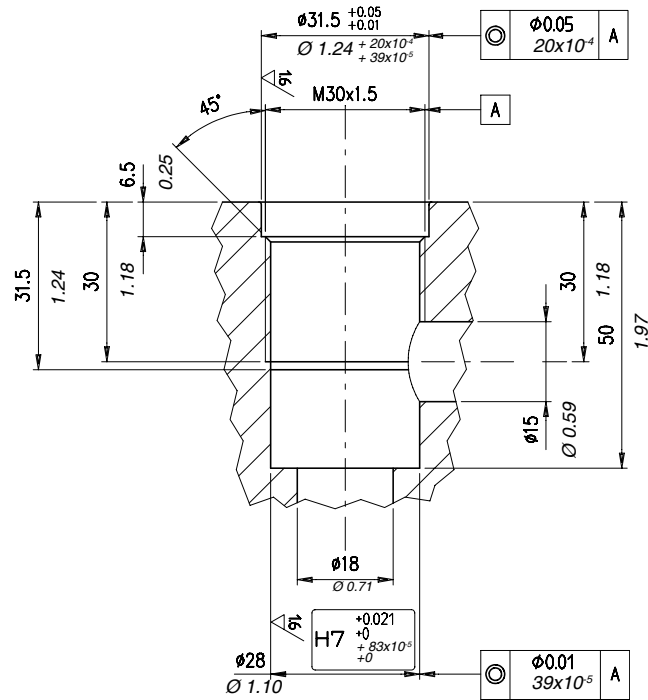

Rougher tool
Code 3UT00050070

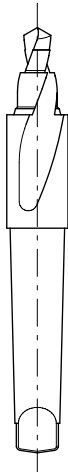

Finisher tool
Code 3UT06A22000P



Tap
Code 3UT08A24F150



Dimensions

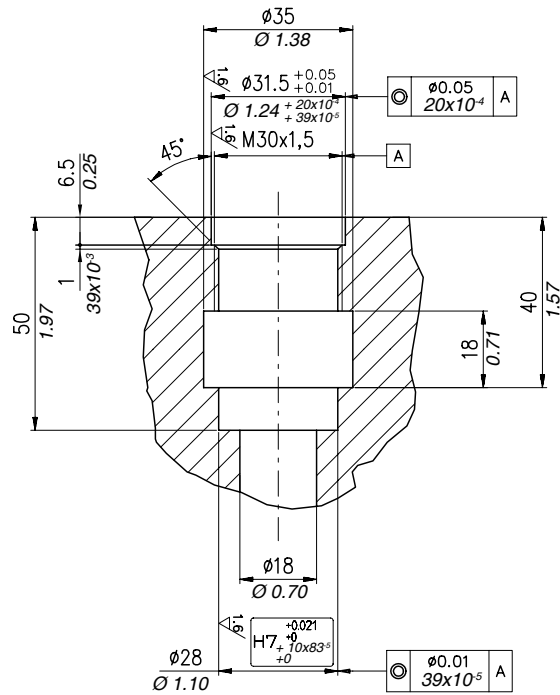

Rougher tool

Code 3UT00050070

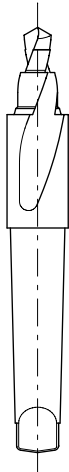

Finisher tool

Code 3UT06A22000P



Tap

Code 3UT08A24F150

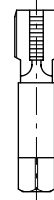

1st edition May 2010

WWW.WALVOIL.COM



D1WWEM01E

