

## Index

Hydraulic diagram	Type	Description	Maximum flow up to		Maximum pressure		Page
			l/min	US gpm	bar	psi	
	<b>VE/B 14/TCW/VG</b>	2 way electric valves, direct acting reinforced poppet type	10	2.6	210	3050	25

**Operation**

With the NA (normally opened) valve version and dropped out solenoid, the oil flow is free from E to U and vice versa. When the solenoid is energized the flow is stopped in both directions.

With the NC (normally closed) valve version and dropped out solenoid, the oil flow is stopped in both directions. When the solenoid is energized the flow is free both from E to U and vice versa.

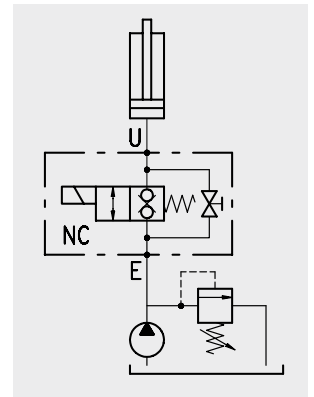

**Performance**

**Body valves**

Type	Maximum flow		Maximum pressure		Solenoids	*Oil leaks from E to U	Weight		Cartridge used
	l/min	US gpm	bar	psi			kg	lb	
VE/B 14/ TCW/VG	10	2.6	210 aluminium and steel body	3050 aluminium and steel body	BT see page155	0.10 cm <sup>3</sup> /min. - 61x10 <sup>-4</sup> in <sup>3</sup> /min. (2 drops) at 210 bar - 3050 psi	0,35	0.77	EW08A see page 36
							aluminium		
							0,77	1.70	
							steel		

\*With oil viscosity of 46 cst

## Dimensions and hydraulic circuit

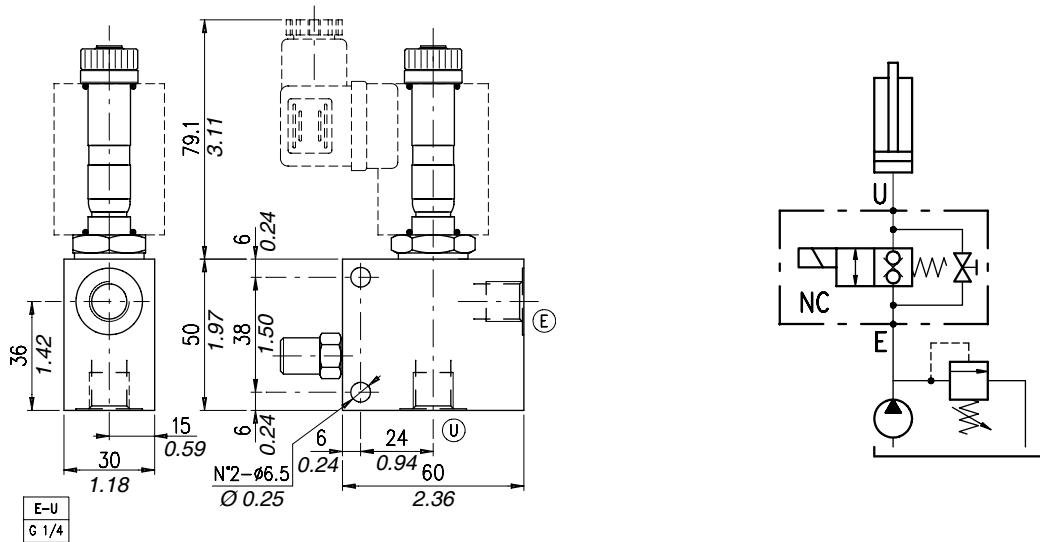

## Rating diagrams

Typical pressure drop vs. flow characteristics

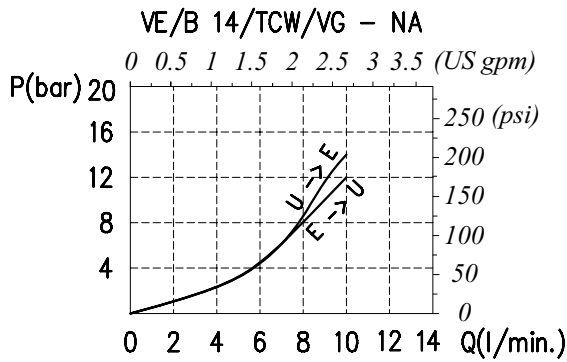

Typical pressure drop vs. flow characteristics

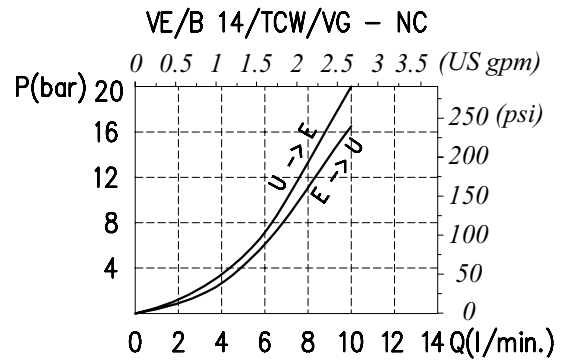

## Order code

VE / B / 14 / □ / TCW / VG / □

Assembly scheme

Body material

NA Normally opened  
NC Normally closed

\_ Aluminium  
ac Steel

## Operation

Multiple coil versions are available to allow use with direct and alternated current.

Thermal insulation class: F (Tmax = 155°C) – (VDE 0580)

Relative duty cycle: ED 100% (VDE 0580)

To assure ED = 100% and perform continuous coil operation, the following conditions should be met:

TA + ΔT < Tmax

Whereas:

-TA = ambient temperature

-ΔT = temperature increase due to operation

-Tmax = maximum admissible temperature according to insulation class

We therefore recommend always checking that the maximum ambient temperature is same as Tmax - ΔT (providing no special operating requirement are there).

**Safety standards (DIN 40050):** IP54 without connector

IP65 with connector

**Admissible voltage range for long lasting and trouble free operations life:** nominal voltage ±10%

## Performance

Type	Resistance Ω  T <sub>A</sub> =20°C 68°F	Current (A)		Power (W) or (VA)  Cold	ΔT	
		Cold	Warm		After 1 hour at: -T <sub>A</sub> =20-25°C 68-77°F -Nominal voltage	
					C°	F°
BE 12 Vcc	7,7	1,56	1,16	18,7 W	110	230
BE 24 Vcc	31	0,77	0,58	18,6 W	110	230
BE 48 Vcc	116	0,41	0,3	19,8 W	115	238
BE 110 Vcc	700	0,157	0,12	17,3 W	105	221
BE 24 Vca (50 Hz)	5,3	1,16	0,87	28 VA	105	221
BE 48 Vca (50 Hz)	21,3	0,6	0,45	28,8 VA	105	221
BE 110 Vca (50 Hz)	108	0,26	0,19	28,6 VA	105	221
BE 220 Vca (50 Hz)	438	0,13	0,09	28,6 VA	105	221
BE 380 Vca (50 Hz)	1400	0,09	0,06	34,2 VA	105	221
BE 24 RAC	27	0,8	0,6	17,3 W	105	221
BE 110 RAC	630	0,157	0,12	15,6 W	100	212
BE 220 RAC	2500	0,08	0,06	15,7 W	100	212
BT 12 Vcc	6,8	1,77	1,15	21 W	-	-
BT 24 Vcc	27	0,89	0,58	21 W	-	-
BT 48 Vcc	110	0,43	0,32	20,3 W	105	221
BT 110 Vcc	700	0,15	0,11	15,7 W	100	212
BT 24 Vca (50 Hz)	4,2	0,94	0,83	22,6 VA	-	-
BT 48 Vca (50 Hz)	15,3	0,73	0,54	35 VA	105	221
BT 110 Vca (50 Hz)	89	0,21	0,18	23,1 VA	-	-
BT 220 Vca (50 Hz)	350	0,1	0,08	22 VA	-	-
BT 24 RAC	90	0,47	0,37	20,7 W	105	221
BT 110 RAC	540	0,2	0,16	21,6 W	110	230
BT 220 RAC	2170	0,1	0,08	21,7 W	105	221

Dimensions

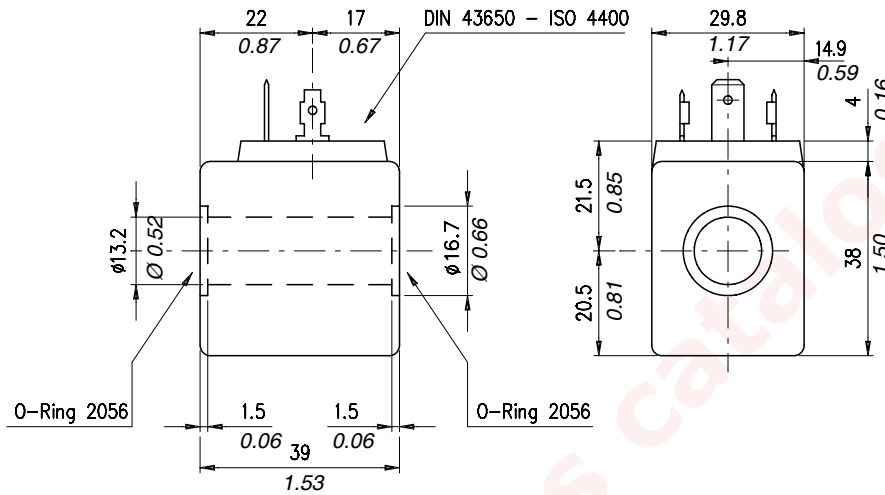

Order code

Type	Ordering code	Ordering code with standard connector	Standard connector code	Connector page
BE 12 Vcc	4SL1000120	5SL1000120	4CN1009990	Page 162 CC-CA
BE 24 Vcc	4SL1000240	5SL1000240		
BE 48 Vcc	4SL1000480	5SL1000480		
BE 110 Vcc	4SL1001100	5SL1001100		
BE 24 Vca (50 Hz)	4SL1010240	5SL1010240		
BE 48 Vca (50 Hz)	4SL1010480	5SL1010480		
BE 110 Vca (50 Hz)	4SL1011100	5SL1011100		
BE 220 Vca (50 Hz)	4SL1012200	5SL1012200		
BE 380 Vca (50 Hz)	4SL1013800	5SL1013800		
BE 24 RAC	4SL1030240	5SL1030240	4CN1010240	Page 162 CL
BE 110 RAC	4SL1031100	5SL1031100	4CN1011100	
BE 220 RAC	4SL1032200	5SL1032200	4CN1012200	

Dimensions

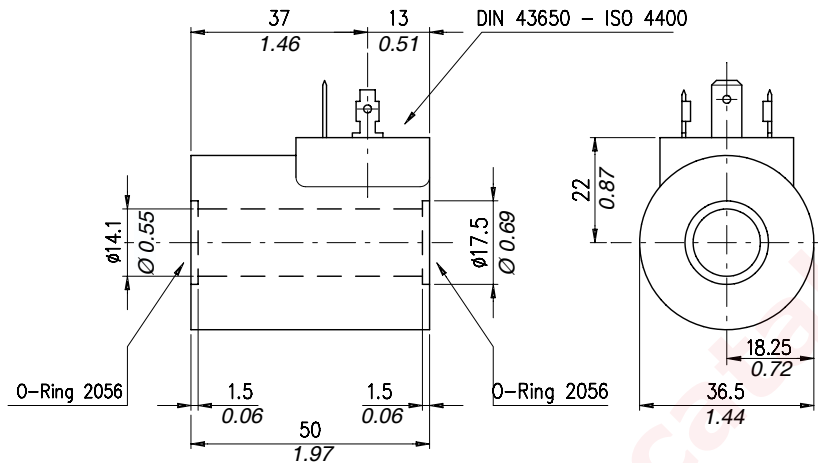

Order code

Type	Ordering code	Ordering code with standard connector	Standard connector code	Connector page
BT 12 Vcc	4SL3000120	5SL3000120	4CN1009990	Page 162 CC-CA
BT 24 Vcc	4SL3000240	5SL3000240		
BT 48 Vcc	4SL3000480	5SL3000480		
BT 110 Vcc	4SL3001100	5SL3001100		
BT 24 Vca (50 Hz)	4SL3010240	5SL3010240		
BT 48 Vca (50 Hz)	4SL3010480	5SL3010480		
BT 110 Vca (50 Hz)	4SL3011100	5SL3011100		
BT 220 Vca (50 Hz)	4SL3012200	5SL3012200		
BT 24 RAC	4SL3030240	5SL3030240	4CN3010240	Page 162 CP
BT 48 RAC	4SL3030480	5SL3030480	4CN3010480	
BT 110 RAC	4SL3031100	5SL3031100	4CN3011100	
BT 220 RAC	4SL3032200	5SL3032200	4CN3012200	

## Coil BE-EC

### Operation

Multiple coil versions are available to allow use with direct and alternated current.

**Thermal insulation class:** F ( $T_{max} = 180^{\circ}\text{C}$ ) – (VDE 0580)

**Relative duty cycle:** ED 100% (VDE 0580)

To assure ED = 100% and perform continuous coil operation, the following conditions should be met:

$T_A + \Delta T < T_{max}$

Whereas:

- $T_A$  = ambient temperature

- $\Delta T$  = temperature increase due to operation

- $T_{max}$  = maximum admissible temperature according to insulation class

We therefore recommend always checking that the maximum ambient temperature is same as  $T_{max} - \Delta T$  (providing no special operating requirement are there).

**Safety standards (DIN 40050):** IP54 without connector

IP65 with connector

**Admissible voltage range for long lasting and trouble free operations life:** nominal voltage  $\pm 10\%$

### Performance

Type	Resistance $\Omega$  $T_A = 20^{\circ}\text{C}$ $68^{\circ}\text{F}$	Current (A)		Power (W) or (VA)  Cold	$\Delta T$	
		Cold	Warm		After 1 hour at: - $T_a = 20-25^{\circ}\text{C}$ $68-77^{\circ}\text{F}$ -Nominal voltage	
					$^{\circ}\text{C}$	$^{\circ}\text{F}$
BE EC36 12 Vcc	6,3	1,9	1,35	22,8 W	115	238
BE EC36 24 Vcc	25,6	0,94	0,66	22,5 W	115	238
BE EC36 24 RAC	20,2	1,07	0,75	23,1 W	115	238
BE EC36 48 RAC	80,8	0,53	0,37	23 W	115	238
BE EC36 110 RAC	420	0,23	0,16	22,8 W	115	238
BE EC36 220 RAC	1720	0,11	0,08	22,7 W	115	238

## Dimensions

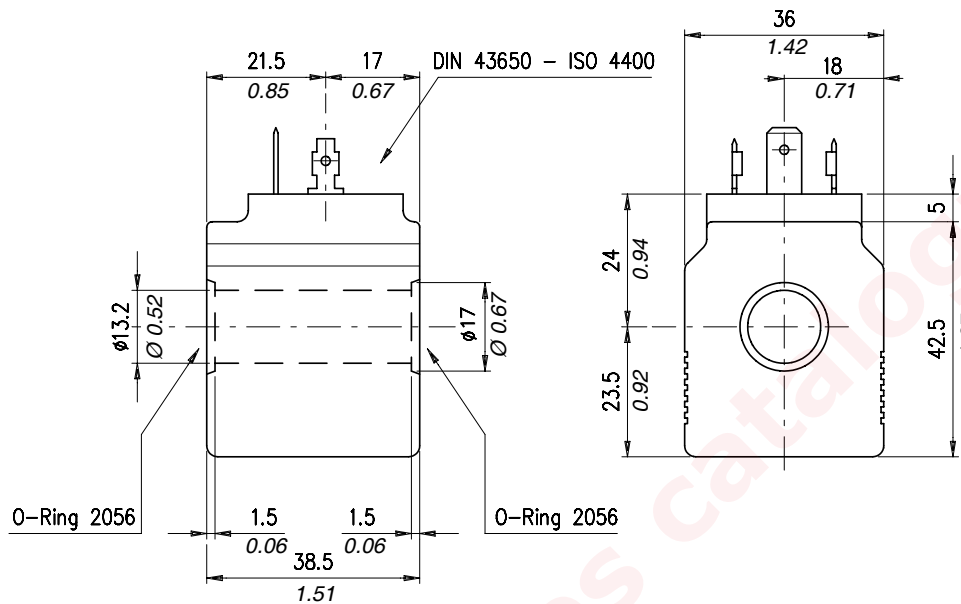

## Order code

Type	Ordering code	Ordering code with standard connector	Standard connector code	Connector page
BE EC36 12 Vcc	4SL2000121	5SL1000120	4CN1009990	Page 162 CC-CA
BE EC36 24 Vcc	4SL2000241	5SL2000241		
BE EC36 24 RAC	4SL2030240	5SL2030240	4CN1010240	Page 162 CL
BE EC36 48 RAC	4SL2030480	5SL2030480	4CN1010480	
BE EC36 110 RAC	4SL2031100	5SL2031100	4CN1011100	
BE EC36 220 RAC	4SL2032200	5SL2032200	4CN1012200	



## Operation

Multiple coil versions are available to allow use with direct and alternated current.

**Thermal insulation class:** F (Tmax=155°C)-(VDE 0580)

**Relative duty cycle:**ED 100% (VDE 0580)

To assure ED=100% and perform continuous coil operation, the following conditions should be met:

$T_A + \Delta T < T_{max}$

Whereas:

T<sub>A</sub> = ambient temperature

ΔT = temperature increase due to operation

T<sub>max</sub> = maximum admissible temperature according to insulation class.

We therefore recommend always checking that the maximum ambient temperature is same as T<sub>max</sub>-ΔT (providing no special operating requirement are there)

**Safety standards (DIN 40050):**

- IP54 without connector

- IP65 with connector

**Admissible voltage range for long lasting and trouble free operations life:** nominal voltage ±10%

## Performance

Type	Resistance Ω  T <sub>A</sub> =20°C 68°F	Current (A)		Power (W) or (VA)  Cold	ΔT (°C)  After 1 hour at: -T <sub>A</sub> =20-25°C 68-77°F -Nominal voltage
		Cold	Warm		
BIN 19 12 Vcc	5,0	2,41	-	29 W	-
BIN 19 24 Vcc	18,6	1,29	-	31 W	-

## Dimensions

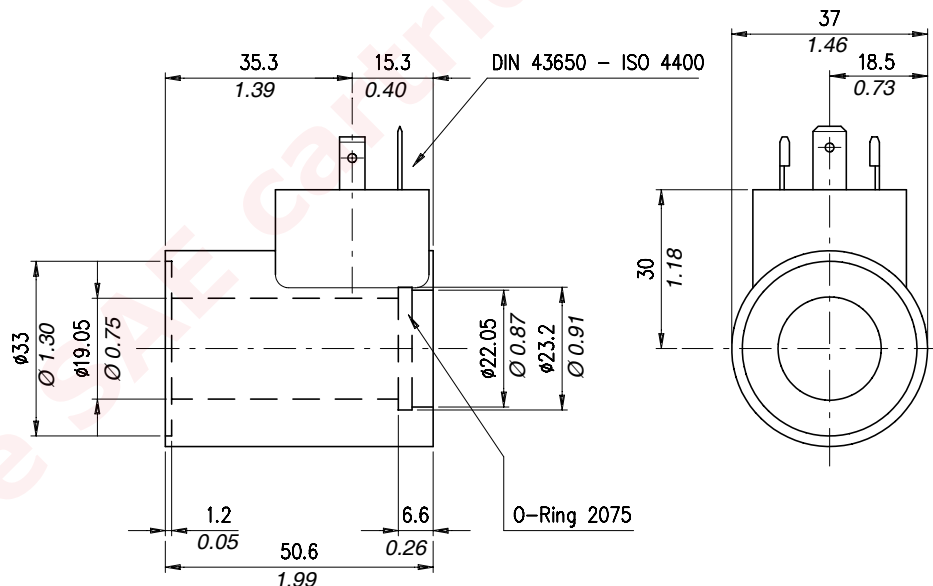

## Order code

Type	Ordering code	Ordering code with standard connector	Standard connector code	Connector page
BIN 19 12 Vcc	4SL6000121	5SL6000121	4CN1009990	Page 162 CC-CA
BIN 19 24 Vcc	4SL2000240	5SL6000240		

**Operation**

Multiple coil versions are available to allow use with direct and alternated current.

**Thermal insulation class:** F(Tmax=155°C)-(VDE 0580)

**Relative duty cycle:** ED100% (VDE 0580)

To assure ED=100% and perform continuous coil operation, the following conditions should be met:

TA+ΔT<Tmax

Whereas:

TA = ambient temperature

TΔ= temperature increase due to operation

Tmax = maximum admissible temperature according to insulation class

We therefore recommend always checking that the maximum ambient temperature is same as Tmax -ΔT (providing no special operating requirement are there).

Safety standards (DIN 40050):

-IP54 without connector

-IP65 with connector

**Admissible voltage range for long lasting and trouble free operations life:** nominal voltage ±10%

**Performance**

Type	Resistance Ω  T <sub>A</sub> =20°C 68°F	Current (A)		Power (W) or (VA)  Cold	ΔT (°C)  After 1 hour at: -T <sub>A</sub> =20-25°C 68-77°C -Nominal voltage
		Cold	Warm		
BIN 22 12 Vcc	4,4	2,72	-	32,7 W	-
BIN 22 24 Vcc	18,6	1,29	-	31 W	-

**Dimensions**

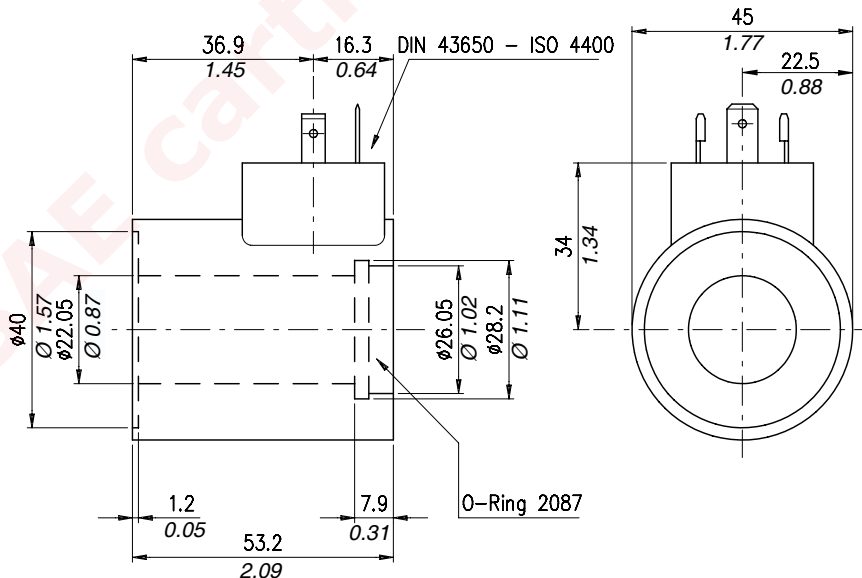

**Order code**

Type	Ordering code	Ordering code with standard connector	Standard connector code	Connector page
BIN 22 12 Vcc	4SL6000122	5SL6000122	4CN1009990	Page 162 CC-CA
BIN 22 24 Vcc	4SL6000241	5SL6000241		

**Operation**

Electric coils for tube diameter 16mm. Multiple coil versions are available to allow use with direct and alternated current.

**Thermal insulation class:** F(Tmax=155°C)-(VDE 0580)

**Relative duty cycle:** ED 100% (VDE 0580)

To assure ED=100% and perform continuous coil operation, the following conditions should be met:

$TA + \Delta T < T_{max}$

Whereas:

TA = ambient temperature

T = temperature increase due to operation

Tmax = maximum admissible temperature according to insulation class

We therefore recommend always checking that the maximum ambient temperature is same as Tmax - $\Delta T$  (providing no special operating requirement are there).

**Safety standards (DIN 40050)**

-IP54 without connector

-IP65 with connector

**Admissible voltage range for long lasting and trouble free operations life:** nominal voltage  $\pm 10\%$

**Performance**

Type	Resistance $\Omega$  $T_A = 20^\circ\text{C}$ $68^\circ\text{C}$	Current (A)		Power (W) or (VA)  Cold	$\Delta T$	
		Cold	Warm		After 1 hour at: - $T_a = 20-25^\circ\text{C}$ $68-77^\circ\text{F}$ -Nominal voltage	
					C°	F°
BC 16 12 Vcc	5,5	2,18	1,52	26,1 W	120	248
BC 16 24 Vcc	22,2	1,08	0,75	25,9 W		
BC 16 26 RAC	26,9	0,97	0,7	25,2 W		
BC 16 24 RAC	17,8	1,21	0,84	26,1 W		
BC 16 48 RAC	72	0,6	0,42	25,9 W		
BC 16 110 RAC	369	0,265	0,19	25,9 W		
BC 16 220 RAC	1508	0,13	0,091	25,5 W		

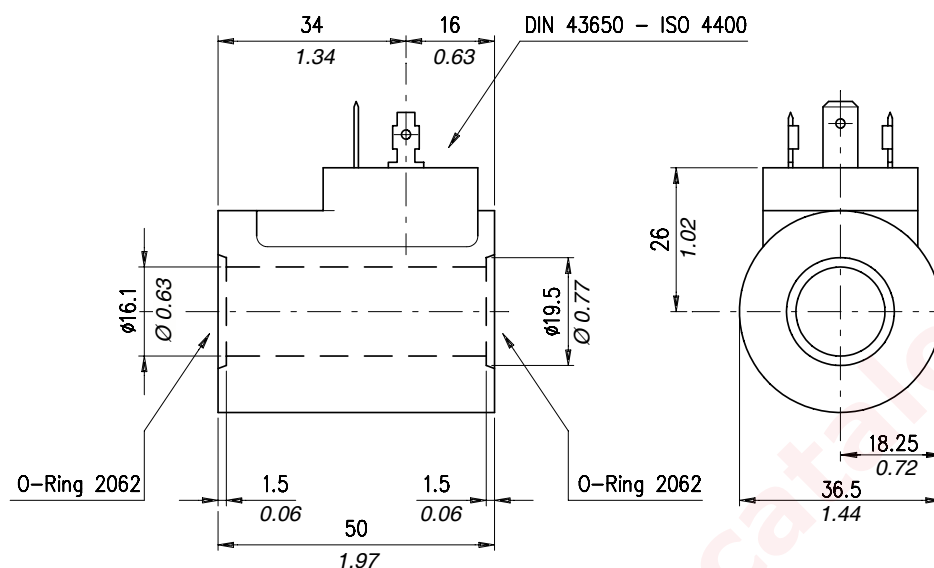

Order code

Type	Ordering code	Ordering code with standard connector	Standard connector code	Connector page
BC 16 12 Vcc	4SL8000120	5SL8000120	4CN1009990	Page 162 CC-CA
BC 16 24 Vcc	4SL8000240	5SL8000240		
BC 16 26 Vcc	4SL8000260	5SL8000260		
BC 16 24 RAC	4SL8030240	5SL8030240	4CN3010240	Page 162 CP
BC 16 48 RAC	4SL8030480	5SL8030480	4CN3010480	
BC 16 110 RAC	4SL8031100	5SL8031100	4CN3011100	
BC 16 220 RAC	4SL8032200	5SL8032200	4CN3012200	

## Operation

There are 3 types of different solenoid connectors:

**"CC-CA"** 2-poles + GROUND electric connectors in compliance with DIN and A/ISO standards 43650 and 4400.

Electric connectors suitable for connection of DC and AC current coils. Type of current must be same as for the coil used.

**"CL"** 2-poles + rectifier + GROUND electric connectors in compliance with DIN and A/ISO standards 43650 and 4400.

Electric connectors suitable for connection of DC current coils BE...RAC. AC current operation only. Use of these poles depends on the type of valve used.

**"CP"** 2-poles + rectifier + GROUND electric connectors in compliance with DIN and A/ISO standards 43650 and 4400.

Electric connectors suitable for connection of DC current coils BT...RAC. AC current operation only. Use of these poles depends on the type of valve used.

Type	Nominal voltage	Maximum capacity of in-built diode	Nominal poles voltage	Max pole voltage	Poles resistance	Max poles section	Cable size options	Cable diameter	Safety standards	Insulation index
CC-CA	AC	-	10 A	16 A	≤ 4 m Ohm	1,5 mm <sup>2</sup> 0.002in <sup>2</sup>	Pg09	6-8 mm 0.24-0.31 in	IP65 (DIN 40050)	VDE0110-1/89
CL	max 250 V DC	1 A								
CP	max 300 V	3 A								

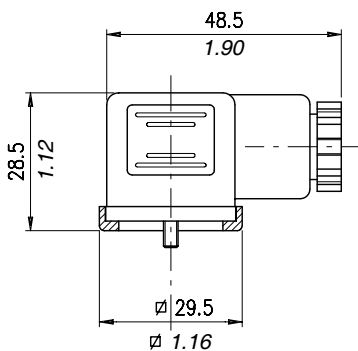

**code number CC-CA Connector**

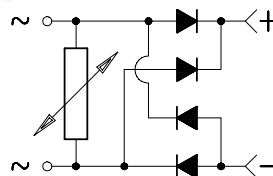
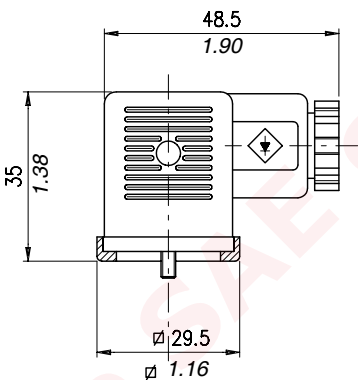

**code number CL Connector**

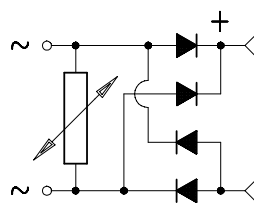
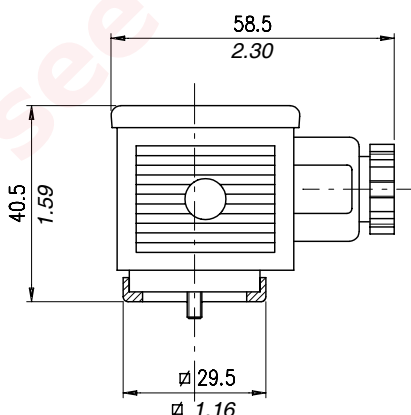

**code number CP Connector**

## Operation

This chapter show main adjusting devices for the valves listed in this catalog.  
These regulations are used to adjust flow rate between inlet and working ports.

## Performance

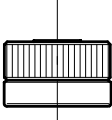
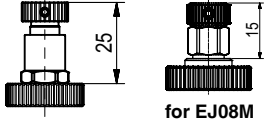
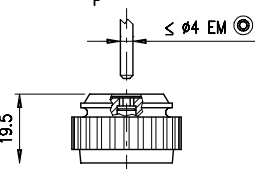
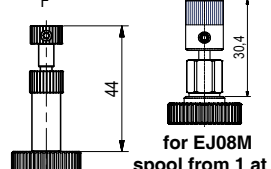
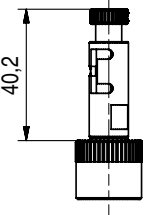
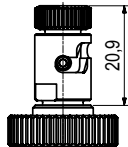
	<p>“N”</p>	 <p>for EJ08M spool from 1 at 5</p>	<p>“T”</p>
	<p>“P”</p>	 <p>for EJ08M spool from 1 at 5</p>	<p>“F”</p>
	<p>“D”</p>		<p>“Q”</p>

### Dimensions

Material	Max. pressure	
	bar	psi
Alluminium	210	3050
Steel	350	5100

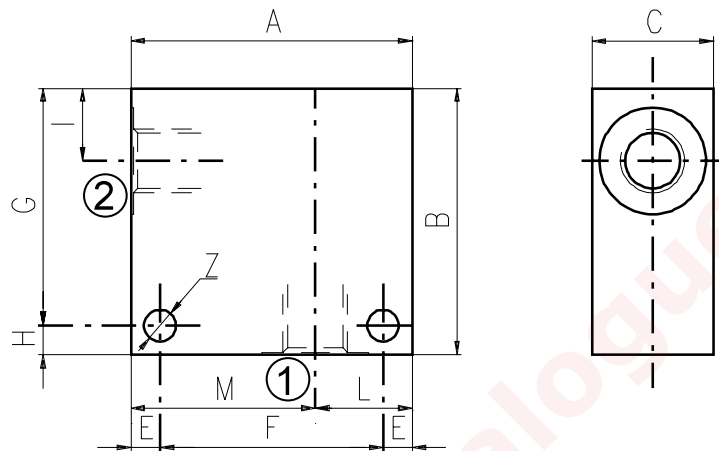

Cavità	Attacchi		A	B	C	E	F	G	H	I	L	M	Z
SAE 8/2	G 1/2	mm	70	65	35	7	56	53	12	14,5	35	35	6,5
		in	2.75	2.56	1.38	0.27	2.20	2.09	0.47	0.57	1.38	1.38	0.25
	G 1/4	mm	50	50	30	6	38	44	6	14,8	20	30	6,5
		in	1.97	1.97	1.18	0.24	1.50	1.73	0.24	0.58	0.79	1.18	0.25
	G 3/8	mm	50	50	30	6	38	44	6	14,8	20	30	6,5
		in	1.97	1.97	1.18	0.24	1.50	1.73	0.24	0.58	0.79	1.18	0.25
	SAE6	mm	50	50	30	6	38	44	6	14,8	20	30	6,5
		in	1.97	1.97	1.18	0.24	1.50	1.73	0.24	0.58	0.79	1.18	0.25
SAE 10/2	G 1/4	mm	60	60	35	6	48	54	6	18,8	25	35	6,5
		in	2.36	2.36	1.38	0.24	1.89	2.12	0.24	0.74	0.98	1.38	0.25
	G 3/8	mm	60	60	35	6	48	54	6	18,8	25	35	6,5
		in	2.36	2.36	1.38	0.24	1.89	2.12	0.24	0.74	0.98	1.38	0.25
	G 1/2	mm	60	60	35	6	48	54	6	18,8	25	35	6,5
		in	2.36	2.36	1.38	0.24	1.89	2.12	0.24	0.74	0.98	1.38	0.25
	SAE8	mm	60	70	35	6	48	64	6	18,8	25	35	6,5
		in	2.36	2.75	1.38	0.24	1.89	2.52	0.24	0.74	0.98	1.38	0.25
	SAE10	mm	70	70	35	6	58	64	6	18,5	35	35	6,5
		in	2.75	2.75	1.38	0.24	2.28	2.52	0.24	0.73	1.38	1.38	0.25
	SAE12	mm	70	70	40	8	54	62	8	22	30	40	8,5
		in	2.75	2.75	1.57	0.31	2.12	2.44	0.31	0.87	1.18	1.57	0.33
SAE 12/2	G 1/2	mm	70	80	40	8	54	72	8	25	30	40	8,5
		in	2.75	3.15	1.57	0.31	2.12	2.83	0.31	0.98	1.18	1.57	0.33
	G 3/4	mm	70	90	40	8	54	82	8	25	30	40	8,5
		in	2.75	3.54	1.57	0.31	2.12	3.23	0.31	0.98	1.18	1.57	0.33
	SAE10	mm	70	85	40	8	54	77	8	25	30	40	8,5
		in	2.75	3.35	1.57	0.31	2.12	3.03	0.31	0.98	1.18	1.57	0.33
	SAE12	mm	70	85	40	8	54	77	8	25	30	40	8,5
		in	2.75	3.35	1.57	0.31	2.12	3.03	0.31	0.98	1.18	1.57	0.33

Dimensions

Cavity	Ports	A	B	C	E	F	G	H	I	L	M	Z	
SAE 16/2	G 1/2	mm	80	90	50	10	60	80	10	25	35	45	10,5
		in	3.15	3.54	1.97	0.39	2.36	3.15	0.39	0.98	1.38	1.77	0.41
	G 3/4	mm	80	90	50	10	60	80	10	25	35	45	10,5
		in	3.15	3.54	1.97	0.39	2.36	3.15	0.39	0.98	1.38	1.77	0.41
	G 1	mm	85	100	60	10	65	90	10	23,5	40	45	10,5
		in	3.35	3.94	2.36	0.39	2.56	3.54	0.39	0.92	1.57	1.77	0.41
	SAE12	mm	80	90	50	10	60	80	10	25	35	45	10,5
		in	3.15	3.54	1.97	0.39	2.36	3.15	0.39	0.98	1.38	1.77	0.41
	SAE16	mm	80	100	50	10	60	90	10	25	35	45	10,5
		in	3.15	3.94	1.97	0.39	2.36	3.54	0.39	0.98	1.38	1.77	0.41

Order code

3/CC /- □ □ /20/□- □-1

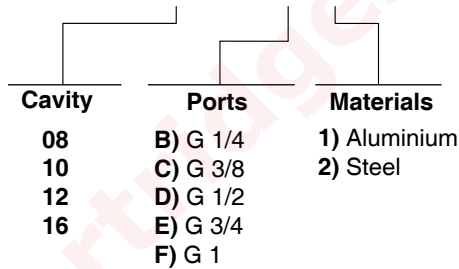



### Dimensions

Material	Max. pressure	
	bar	psi
Aluminium	210	3050
Steel	350	5100

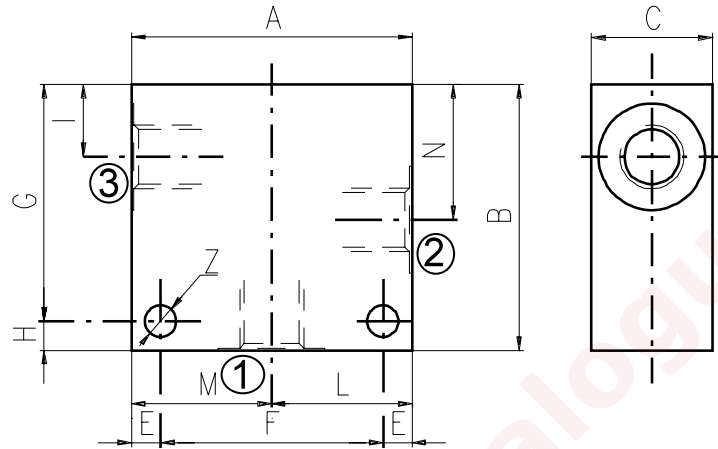

Cavity	Ports		A	B	C	E	F	G	H	I	L	M	N	Z
SAE 8/3	G 1/4	mm	60	60	30	7	46	48	12	14,8	30	30	29,1	6,5
		in	2.36	2.36	1.18	0.27	1.81	1.89	0.47	0.58	1.18	1.18	1.14	0.25
	G 3/8	mm	60	60	30	7	46	48	12	14,5	30	30	29,1	6,5
		in	2.36	2.36	1.18	0.27	1.81	1.89	0.47	0.57	1.18	1.18	1.14	0.25
	G 1/2	mm	70	65	35	7	56	53	12	14,5	35	35	29,1	6,5
		in	2.75	2.56	1.38	0.27	2.20	2.09	0.47	0.57	1.38	1.38	1.14	0.25
SAE6	mm	60	60	30	7	46	48	12	14,5	30	30	29,1	6,5	
	in	2.36	2.36	1.18	0.27	1.81	1.89	0.47	0.57	1.18	1.18	1.14	0.25	
SAE 10/3	G 1/4	mm	60	65	35	6	48	59	6	18	30	30	34,5	7
		in	2.36	2.56	1.38	0.24	1.89	2.32	0.24	0.70	1.18	1.18	1.36	0.27
	G 3/8	mm	60	65	35	6	48	59	6	18,8	30	30	34,5	7
		in	2.36	2.56	1.38	0.24	1.89	2.32	0.24	0.74	1.18	1.18	1.36	0.27
	G 1/2	mm	65	70	35	6	53	64	6	18,8	32,5	32,5	34,5	7
		in	2.56	2.75	1.38	0.24	2.09	2.52	0.24	0.74	1.28	1.28	1.36	0.27
	SAE6	mm	65	70	35	6	53	64	6	18,8	32,5	32,5	34,5	7
		in	2.56	2.75	1.38	0.24	2.09	2.52	0.24	0.74	1.28	1.28	1.36	0.27
	SAE8	mm	65	70	35	6	53	64	6	18,8	32,5	32,5	34,5	7
		in	2.56	2.75	1.38	0.24	2.09	2.52	0.24	0.74	1.28	1.28	1.36	0.27
SAE 12/3	G 1/2	mm	70	100	40	8	54	92	8	25	35	35	53,5	8,5
		in	2.75	3.94	1.57	0.31	2.12	3.6	0.31	0.98	1.38	1.38	2.10	0.33
	G 3/4	mm	90	100	50	10	70	90	10	25,1	45	45	53,5	10,5
		in	3.54	3.94	1.97	0.39	2.75	3.54	0.39	0.99	1.77	1.77	2.11	0.41
	SAE10	mm	80	100	40	8	64	92	8	25	40	40	53,5	8,5
		in	3.15	3.94	1.57	0.31	2.52	3.6	0.31	0.98	1.57	1.57	2.11	0.33
	SAE12	mm	80	100	45	8	64	92	8	25	40	40	53,5	8,5
		in	3.15	3.94	1.77	0.31	2.52	3.6	0.31	0.98	1.57	1.57	2.11	0.33

Dimensions

Cavity	Ports	A	B	C	E	F	G	H	I	L	M	N	Z	
SAE 16/3	G 3/4	mm	90	100	50	10	70	90	10	25,1	45	45	53,5	10,5
		in	3.54	3.94	1.97	0.39	2.75	3.54	0.39	0.99	1.77	1.77	2.11	0.41
	SAE12	mm	90	105	50	10	70	95	10	25,1	45	45	53,5	10,5
		in	3.54	4.13	1.97	0.39	2.75	3.74	0.39	0.99	1.77	1.77	2.11	0.41
	SAE16	mm	90	105	50	10	70	95	10	25,1	45	45	53,5	10,5
		in	3.54	4.13	1.97	0.39	2.75	3.74	0.39	0.99	1.77	1.77	2.11	0.41

Order code

3/CC /- □ □ /30/□- □-1

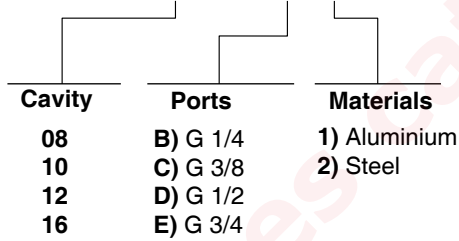

### Dimensions

Material	Max. pressure	
	bar	psi
Aluminium	210	3050
Steel	350	5100

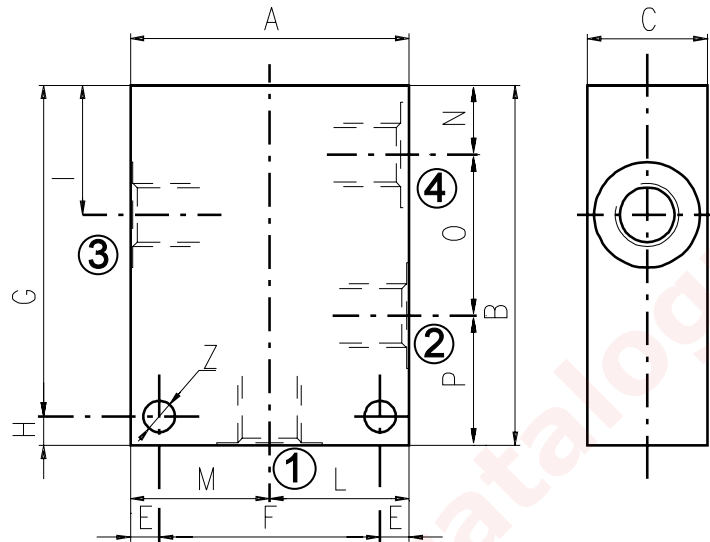

Cavity	Ports		A	B	C	E	F	G	H	I	L	M	N	O	P	Z
SAE 8/4	G 1/4	mm	60	75	30	7	46	63	12	29,1	30	30	14,8	29,1	31,1	6,5
		in	2.36	2.95	1.18	0.27	1.81	2.48	0.47	1.14	1.18	1.18	0.58	1.14	1.22	0.25
	SAE6	mm	60	75	30	7	46	63	12	29,1	30	30	14,8	29,1	31,1	6,5
		in	2.36	2.95	1.18	0.27	1.81	2.48	0.47	1.14	1.18	1.18	0.58	1.14	1.22	0.25
SAE 10/4	G 3/8	mm	60	85	35	6	48	79	6	34,5	30	30	18,8	31,7	34,5	7
		in	2.36	3.35	1.38	0.24	1.89	3.11	0.24	1.36	1.18	1.18	0.74	1.25	1.36	0.27
	G 1/2	mm	70	85	35	6	58	79	6	34,5	35	35	18,8	31,7	34,5	7
		in	2.75	3.35	1.38	0.24	2.28	3.11	0.24	1.36	1.38	1.38	0.74	1.25	1.36	0.27
	SAE6	mm	60	85	35	6	48	79	6	34,5	30	30	18,8	31,7	34,5	7
		in	2.36	3.35	1.38	0.24	1.89	3.11	0.24	1.36	1.18	1.18	0.74	1.25	1.36	0.27
SAE8	mm	70	85	35	6	58	79	6	34,5	35	35	18,8	31,7	34,5	7	
	in	2.75	3.35	1.38	0.24	2.28	3.11	0.24	1.36	1.38	1.38	0.74	1.25	1.36	0.27	
SAE 12/4	G 1/2	mm	80	115	40	8	64	107	8	44	40	40	22	44,5	48,5	8,5
		in	3.15	4.53	1.57	0.31	2.52	4.21	0.31	1.73	1.57	1.57	0.87	1.75	1.9	0.33
	SAE10	mm	80	115	40	8	64	107	8	44	40	40	22	44,5	48,5	8,5
		in	3.15	4.53	1.57	0.31	2.52	4.21	0.31	1.73	1.57	1.57	0.87	1.75	1.9	0.33
SAE 16/4	G 3/4	mm	100	130	50	10	80	120	10	53,5	50	50	25,1	56,9	48	10,5
		in	3.94	5.12	1.97	0.39	3.15	4.72	0.39	2.11	1.97	1.97	0.99	2.24	1.89	0.41

3/CC /- □ □ /40/□- □-1

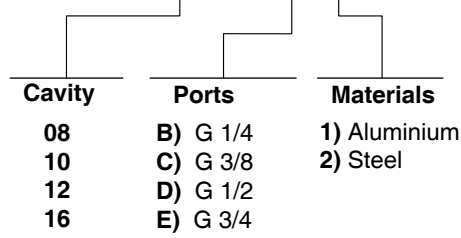

see SAE cartridges catalogue

# Informations

## How to order valves with body

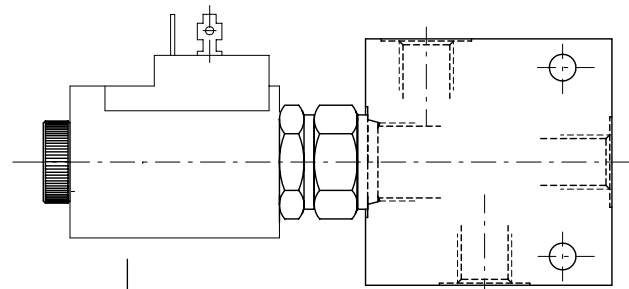

CARTRIDGE CODE

**EJ-08A/10NB**

BILLET CODE

**B- 1-1**

Cavity	Ports	Materials
08	B) G 1/4	1) Aluminium
10	C) G 3/8	
12	D) G 1/2	
16	E) G 3/4	
	F) G 1	
	J) SAE 6	2) Steel
	K) SAE 8	
	L) SAE 10	
	M) SAE 12	
	N) SAE 16	

VARIATION "A": the dimensions with "\*" are related to the variation "A". Features of variation "A" are required only if noted on specific product catalogue page.

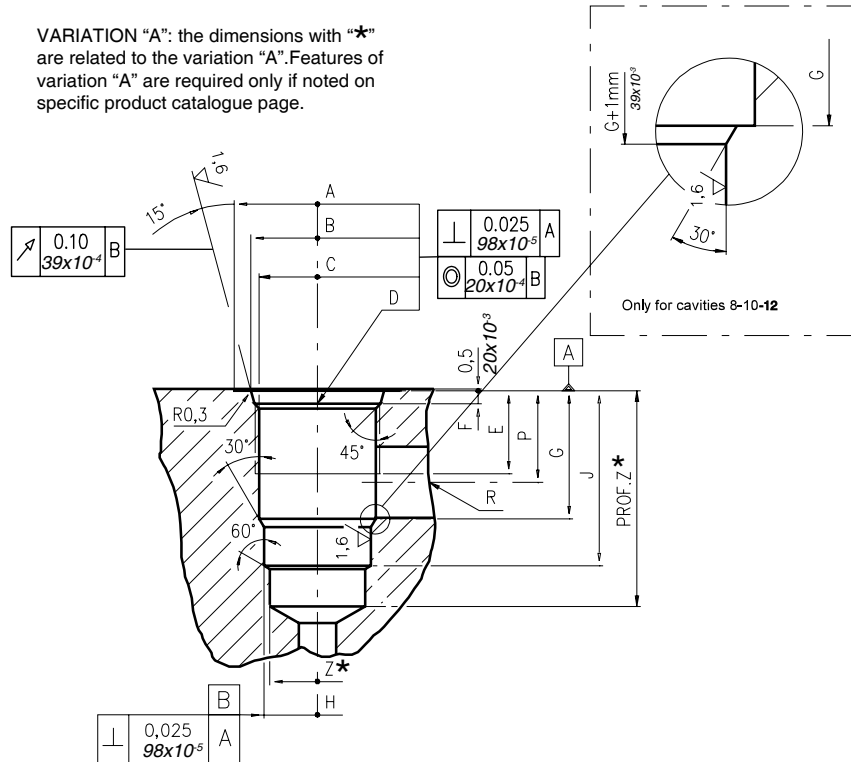

Cavity	A	B ±0,05	C ±0,05	D	E	F	G	H ±0,02	J	K ±0,02	L	M ±0,02	N	P	R øMAX	S øMAX	T øMAX	U øMAX	V øMAX	X øMAX	Z * øMIN	Prof. * MIN	
																							mm
08/2	mm	27	20,66	17,42	3/4-16 UNF	12,50	2,50	18,20	12,72	29,50	-	-	-	-	14,00	8,00	-	-	-	-	-	12,00	39
	in	1.06	0.81	0.68		0.49	0.10	0.72	0.50	1.16	-	-	-	-	0.55	0.31	-	-	-	-	-	0.47	1.53
10/2	mm	30	24,00	20,62	7/8-14 UNF	16,00	2,80	24,00	15,90	33,50	-	-	-	-	18,30	11,00	-	-	-	-	-	14,50	40
	in	1.18	0.94	0.81		0.63	0.11	0.94	0.62	1.32	-	-	-	-	0.72	0.43	-	-	-	-	-	0.57	1.57
12/2	mm	38	29,23	24,73	1 1/16-12 UNF	19,00	3,50	34,15	22,25	46,80	-	-	-	-	24,50	19,00	-	-	-	-	-	21,50	60
	in	1.50	1.15	0.97		0.75	0.14	1.34	0.87	1.84	-	-	-	-	0.96	0.75	-	-	-	-	-	0.85	2.36
16/2	mm	45	35,58	31,34	1 5/16-12 UNF	22,00	3,50	34,00	28,62	47,00	-	-	-	-	24,50	19,00	-	-	-	-	-	25,50	70
	in	1.77	1.40	1.23		0.87	0.14	1.34	1.13	1.85	-	-	-	-	0.96	0.75	-	-	-	-	-	1.00	2.75

Rougher tool

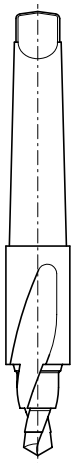

Cavity	Code number
08/2	3UT03416UNF
10/2	3UT07814UNF
12/2	3UT0111612UN
16/2	3UT0151612UN

Finisher tool

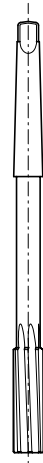

Cavity	Code number
08/2	3UT00053190
10/2	3UT00056610
12/2	3UT00054090
16/2	3UT00054510

Tap



Cavity	Code number
08/2	3UT06A1270N
10/2	3UT00054580
12/2	3UT00054670
16/2	3UT00054520

Cavity plugs

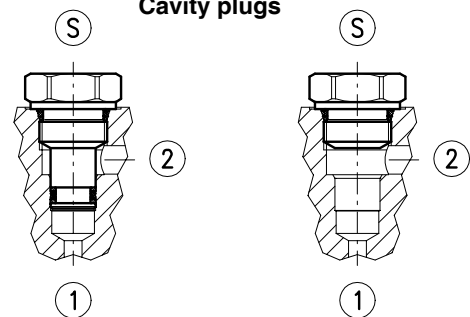

Cavity	Code number	①	②	Ⓢ
08/2	3XTP3533700	X	X	X
	4TP5531500	0	0	X
10/2	3XTP3544200	X	X	X
	3XTP1542300	0	0	X
12/2	3XTP3555400	X	X	X
	3XTP1552900	0	0	X
16/2	3XTP3575500	X	X	X
	3XTP1572900	0	0	X

X=Closed 0=Open

### Dimensions

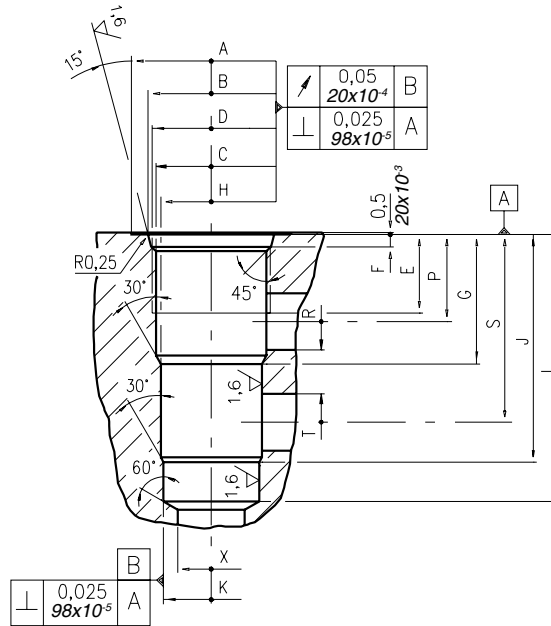

\	A	B ±0,05	C ±0,05	D	E	F	G	H ±0,02	J	K ±0,02	L	M ±0,02	N	P	R øMAX	S	T øMAX	U	V øMAX	X øMAX	Z øMIN	Prof. Z MIN	
08/3	mm	27	20,66	17,42	3/4-16 UNF	12,50	2,5	19,10	15,90	33,30	14,30	43,30	-	-	14,30	5,50	28,60	5,50	-	-	12,50	-	-
	in	1.06	0.81	0.68		0.49	0.10	0.75	0.62	1.31	0.56	1.70			0.56	0.22	1.12	0.22			0.49		
10/3	mm	30	24,00	20,62	7/8-14 UNF	16,00	2,80	23,10	17,50	39,60	15,90	47,60	-	-	18,30	6,50	34,00	6,50	-	-	14,00	-	-
	in	1.18	0.94	0.81		0.63	0.11	0.94	0.69	1.56	0.62	1.87			0.72	0.25	1.34	0.25			0.55		
12/3	mm	38	29,23	24,73	1 1/16-12 UNF	19,00	3,56	36,60	23,82	63,50	22,25	75,40	-	-	24,50	16,00	53,00	16,00	-	-	19,00	-	-
	in	1.50	1.15	0.97		0.75	0.14	1.44	0.94	2.5	0.88	2.97			0.96	0.63	2.09	0.63			0.75		
16/3	mm	45	35,6	31,34	1 5/16-12 UNF	22,00	3,5	36,50	28,62	64,30	27,02	75,38	-	-	24,60	16,00	53,00	16,00	-	-	19,00	-	-
	in	1.77	1.40	1.23		0.87	0.14	1.44	1.13	2.53	1.06	2.97			0.97	0.63	2.09	0.63			0.75		

Rougher tool

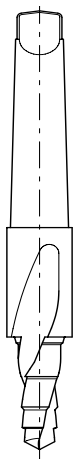

Cavity	Code number
08/3	3UT00052190
10/3	3UT00054170
12/3	3UT00054290
16/3	3UT00054470

Finisher tool



Cavity	Code number
08/3	3UT00052740
10/3	3UT00054180
12/3	3UT00054300
16/3	3UT00054480

Tap



Cavity	Code number
08/3	3UT03416UNF
10/3	3UT07814UNF
12/3	3UT0111612UN
16/3	3UT0151612UN

Cavity plugs

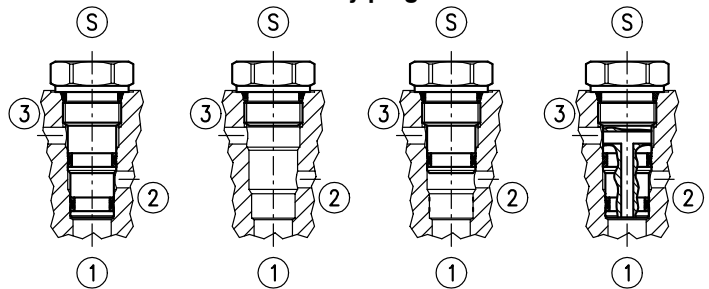

Cavity	Code number	①	②	③	Ⓢ
08/3	3XTP3535100	X	X	X	X
	4TP5531500	0	0	0	X
	3XTP3534000	0	0	X	X
	3XTP3534800	0	X	0	X
10/3	3XTP3545700	X	X	X	X
	3XTP1542300	0	0	0	X
	3XTP3545701	0	X	0	X
12/3	3XTP3558200	X	X	X	X
	3XTP1552900	0	0	0	X
	3XTP3558201	0	X	0	X
16/3	3XTP3578400	X	X	X	X
	3XTP1572900	0	0	0	X

X=Closed 0=Open

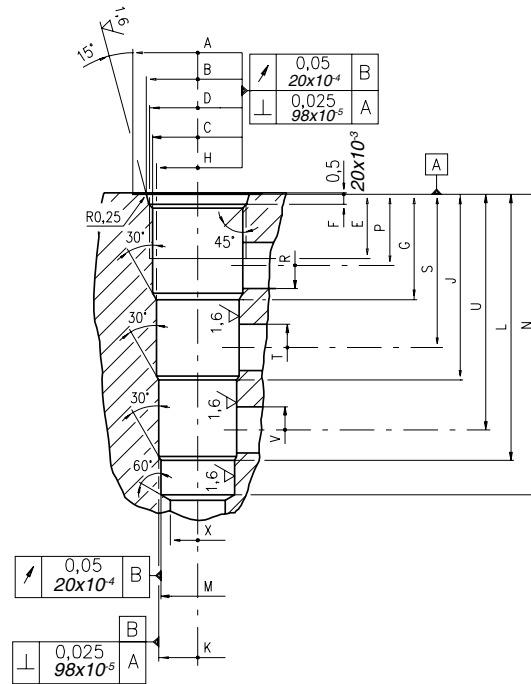

\		A	B ±0,05	C ±0,05	D	E	F	G	H ±0,02	J	K ±0,02	L	M ±0,02	N	P	R øMAX	S	T øMAX	U	V øMAX	X øMAX	Z ø MIN	Prof. Z MIN
		08/4	mm	28,00		20,66	17,42	3/4-16 UNF	12,50	2,50	19,10	15,90	33,30	14,30	47,60	12,72	57,60	14,30	5,50	28,60	5,50	42,90	5,50
	in	1.10	0.81	0.68		0.49	0.10		0.75	0.62	1.31	0.56	1.87	0.50	2.27	0.56	0.22	1.12	0.22	1.69	0.22	0.43	-
10/4	mm	30	24,00	20,62	7/8-14 UNF	16,00	2,80	23,60	19,08	39,60	17,50	55,40	15,90	63,50	18,30	6,50	34,00	6,50	50,00	6,50	14,00	-	-
	in	1.18	0.94	0.81			0.63	0.11	0.93	0.75	1.56	0.69	2.18	0.62	2.50	0.72	0.26	1.34	0.25	1.97	0.25	0.55	-
12/4	mm	38	29,23	24,73	1 1/16-12 UNF	19,00	3,56	29,50	23,82	51,50	22,25	73,60	20,65	83,33	21,50	11,00	43,50	11,00	66,00	11,00	19,00	-	-
	in	1.50	1.15	0.97			0.75	0.14	1.16	0.94	2.03	0.87	2.90	0.81	3.28	0.85	0.43	1.71	0.43	2.60	0.43	0.75	-
16/4	mm	45	35,60	31,34	1 5/16-12 UNF	22,00	3,50	36,50	28,62	64,30	27,02	92,07	25,45	104,00	24,60	16,00	53,00	16,00	81,50	16,00	19,00	-	-
	in	1.77	1.40	1.23			0.87	0.14	1.44	1.13	2.53	1.06	3.62	1.00	4.09	0.97	0.63	2.09	0.63	3.21	0.63	0.75	-

Rougher tool

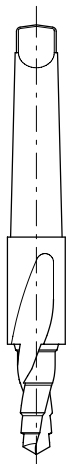

Cavity	Code number
08/4	3UT00052040
10/4	3UT00054250
12/4	3UT00054410
16/4	3UT00054820

Finisher



Cavity	Code number
08/4	3UT00052020
10/4	3UT00054260
12/4	3UT00054420
16/4	3UT00054830

Tap



Cavity	Code number
08/4	3UT03416UNF
10/4	3UT07814UNF
12/4	3UT111612UN
16/4	3UT0151612UN

Cavity plugs

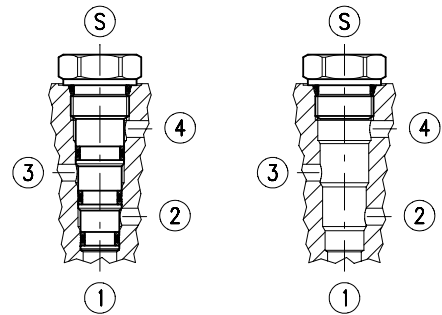

Cavity	Code number	①	②	③	④	Ⓢ
08/4	3XTP3536500	X	X	X	X	X
	4TP5531500	0	0	0	0	X
10/4	3XTP3548301	X	X	X	X	X
	3XTP1542300	0	0	0	0	X
12/4	3XTP3559300	X	X	X	X	X
	3XTP1552900	0	0	0	0	X
16/4	3XTP357B300	X	X	X	X	X
	3XTP1572900	0	0	0	0	X

X=Closed 0=Open



## Dimensions

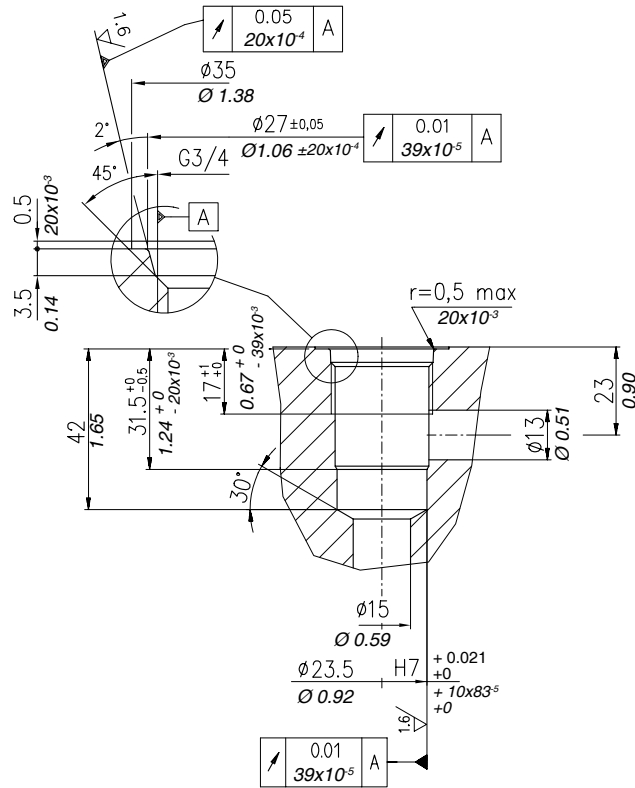

**Rougher tool**  
Cod.3UT00052300

**Finisher**  
Cod.3UT00055020

**Tap**  
Cod.3UT09A34F14G

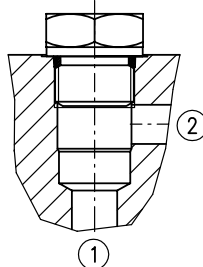
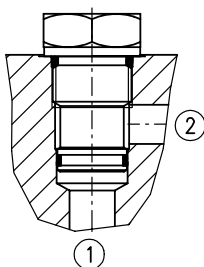
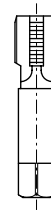
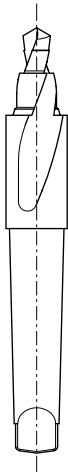

X = Closed ; 0 = Open

Code number	①	②
3XTP3145100	X	X
3XTP5142001	0	0

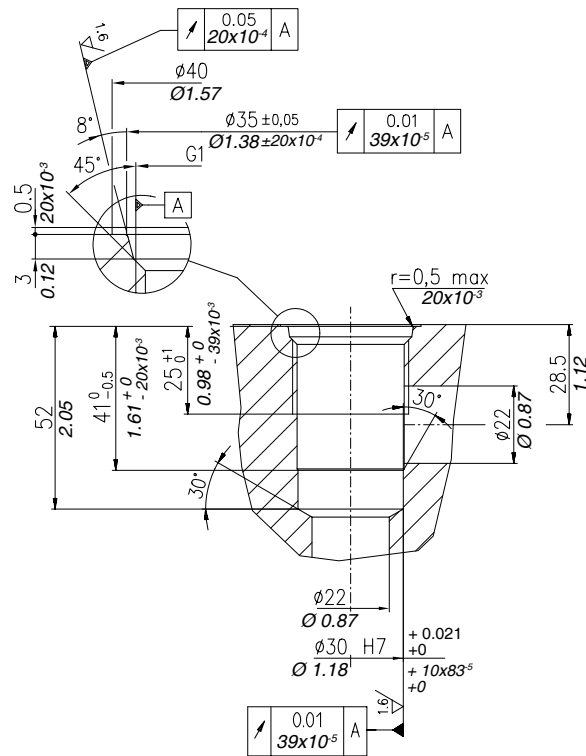

**Rougher tool**  
Cod.3UT00050870A

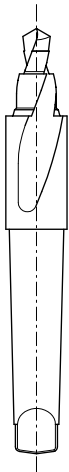

**Finisher tool**  
Cod.3UTO6A3000N



**Tap**  
Cod.3UT09A10F11G

