

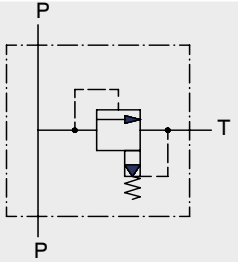

# Pressure relief valves

Hydraulic diagram	Type	Description	Maximum flow up to		Maximum pressure		Page
			l/min	US gpm	bar	psi	
	VMPP/B/L	Pilot-operated valves, spool type	120	32	350	5100	65

**Operation**

Allows oil flow from P (1) to T (2) when pressure in P (1) reaches the setting of the spring.

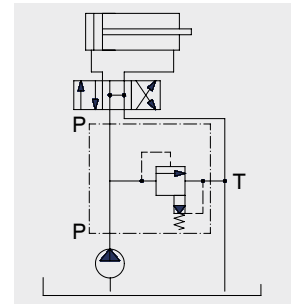

**Performance**

**Body Valves**

Type	Flow max.		Press.max		Application range with standard spring *	Hysteresis	Oil leaks from P to T	Cavities and tool	Weight	
	l/min	US gpm	bar	psi					kg	lb
VMPP/B/L 10	70	18	350	5100	<b>TB)</b> 5÷40 bar - 72.5÷580 psi (test setting 20 bar - 290 psi at 5 l/min. - 1.32 US gpm) pressure increase by steps 8 bar - 116 psi per screw turn <b>TS)</b> 20÷400 bar - 290÷5800 psi (test setting 150 bar - 2200 psi at 5 l/min. - 1.32 gpm) pressure increase by steps 120 bar - 1750 psi per screw turn	95% of the setting value for flow capacity 1 l/min. - 0.26 US gpm-	20 cm <sup>3</sup> /min. - 1.22 in <sup>3</sup> /mm at 100 bar - 1450 psi	Cavity VMP 10 see page 115	steel 1.4	steel 3.09
VMPP/B/L 20	120	32			<b>TB)</b> 5÷40 bar - 72.5÷580 psi (test setting 20 bar - 290 psi at 5 l/min. - 1.32 US gpm) pressure increase by steps 15 bar - 217 psi per screw turn <b>TS)</b> 20÷400 bar - 290÷5800 psi (test setting 150 bar - 2200 psi at 5 l/min. - 1.32 gpm) pressure increase by steps 120 bar - 1667 psi per screw turn				25 cm <sup>3</sup> /min. - 1.52 in <sup>3</sup> /mm at 100 bar - 1450 psi-	Cavity VMP 20 see page 116

\*To perform setting of the valve see the pressure drop/ flow diagram

## Dimensions and hydraulic circuit

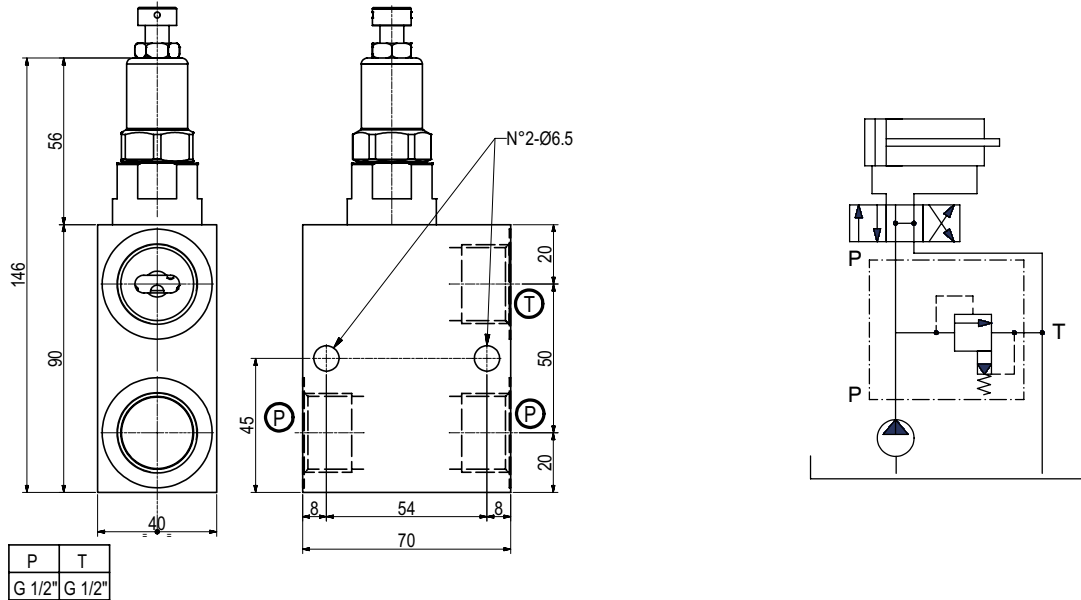

## Rating diagrams

Typical pressure drop vs. flow characteristic

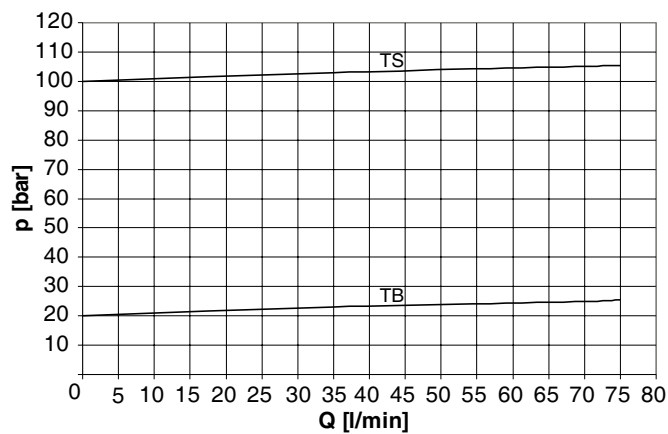

## Order code

VMPP/B/L 10-12/□□.□/□□

**Pressure setting**

TB) 5÷40  
TS) 20÷400

**Adjustments**  
(see page 105)

V (handknob)  
W (copped adjustment)

**Body material**

\_ Aluminium  
ac Steel

Dimensions and hydraulic circuit

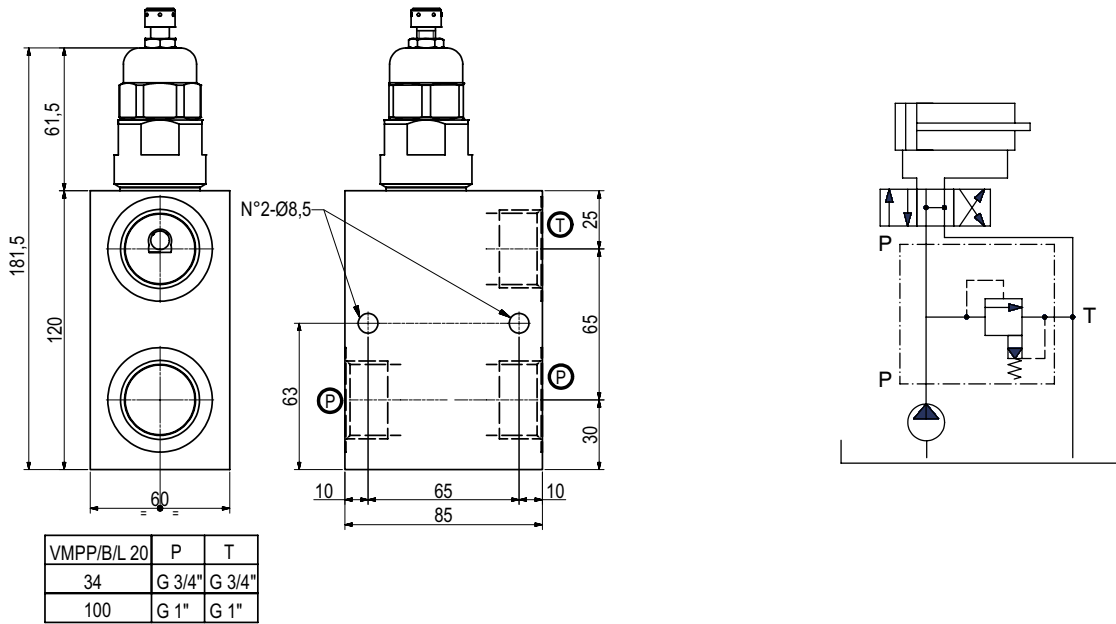

Rating diagrams

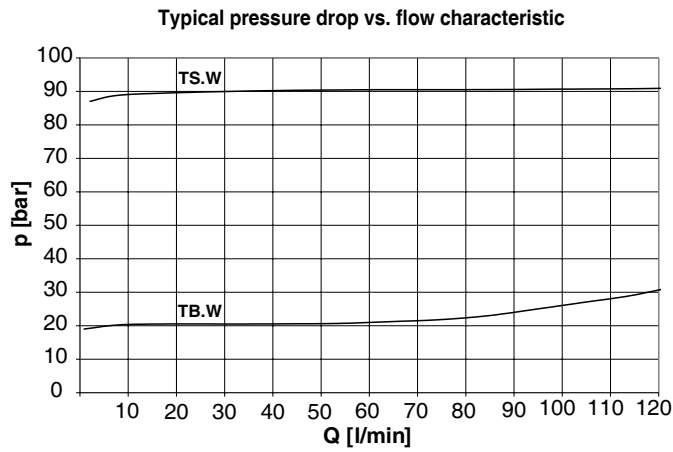

Order code

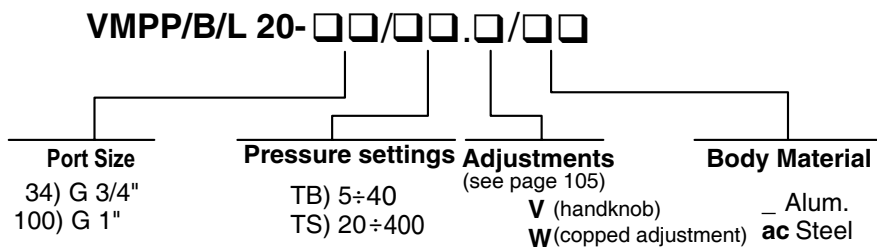

## Description and operation

This chapter show main adjusting devices for the valves listed in this catalog.  
These regulations are used to adjust flow rate between inlet and working ports.

## Performance

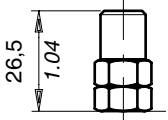
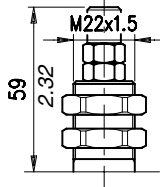
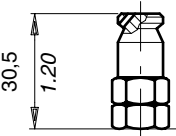
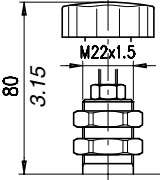
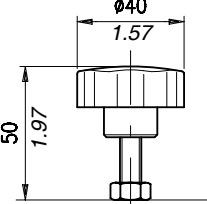
	<p><b>Screw "S"</b></p>		<p><b>Panel mount "P"</b></p>
	<p><b>Copped adjustment "W"</b></p>		<p><b>Panel mount+handknob "PV"</b></p>
	<p><b>Handknob "V"</b></p>		

### Dimensions

Material	Max. pressure	
	bar	psi
Alluminium	210	3050
Steel	350	5100

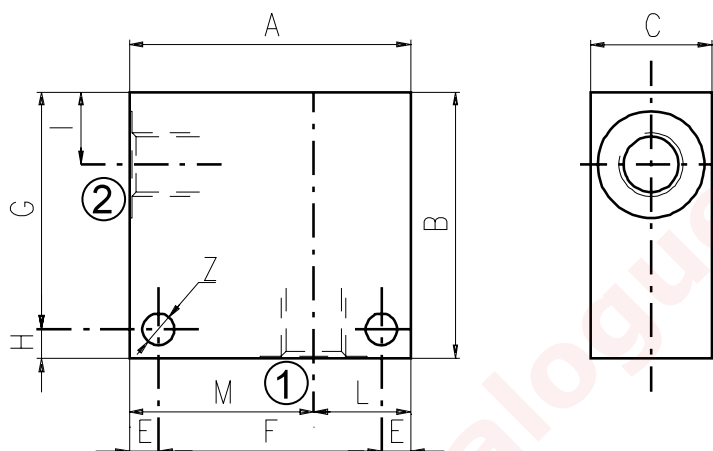

Cavità	Attacchi		A	B	C	E	F	G	H	I	L	M	Z
SAE 8/2	G 1/2	mm	70	65	35	7	56	53	12	14,5	35	35	6,5
		in	2.75	2.56	1.38	0.27	2.20	2.09	0.47	0.57	1.38	1.38	0.25
	G 1/4	mm	50	50	30	6	38	44	6	14,8	20	30	6,5
		in	1.97	1.97	1.18	0.24	1.50	1.73	0.24	0.58	0.79	1.18	0.25
	G 3/8	mm	50	50	30	6	38	44	6	14,8	20	30	6,5
		in	1.97	1.97	1.18	0.24	1.50	1.73	0.24	0.58	0.79	1.18	0.25
	SAE6	mm	50	50	30	6	38	44	6	14,8	20	30	6,5
		in	1.97	1.97	1.18	0.24	1.50	1.73	0.24	0.58	0.79	1.18	0.25
SAE 10/2	G 1/4	mm	60	60	35	6	48	54	6	18,8	25	35	6,5
		in	2.36	2.36	1.38	0.24	1.89	2.12	0.24	0.74	0.98	1.38	0.25
	G 3/8	mm	60	60	35	6	48	54	6	18,8	25	35	6,5
		in	2.36	2.36	1.38	0.24	1.89	2.12	0.24	0.74	0.98	1.38	0.25
	G 1/2	mm	60	60	35	6	48	54	6	18,8	25	35	6,5
		in	2.36	2.36	1.38	0.24	1.89	2.12	0.24	0.74	0.98	1.38	0.25
	SAE8	mm	60	70	35	6	48	64	6	18,8	25	35	6,5
		in	2.36	2.75	1.38	0.24	1.89	2.52	0.24	0.74	0.98	1.38	0.25
	SAE10	mm	70	70	35	6	58	64	6	18,5	35	35	6,5
		in	2.75	2.75	1.38	0.24	2.28	2.52	0.24	0.73	1.38	1.38	0.25
SAE12	mm	70	70	40	8	54	62	8	22	30	40	8,5	
	in	2.75	2.75	1.57	0.31	2.12	2.44	0.31	0.87	1.18	1.57	0.33	
SAE 12/2	G 1/2	mm	70	80	40	8	54	72	8	25	30	40	8,5
		in	2.75	3.15	1.57	0.31	2.12	2.83	0.31	0.98	1.18	1.57	0.33
	G 3/4	mm	70	90	40	8	54	82	8	25	30	40	8,5
		in	2.75	3.54	1.57	0.31	2.12	3.23	0.31	0.98	1.18	1.57	0.33
	SAE10	mm	70	85	40	8	54	77	8	25	30	40	8,5
		in	2.75	3.35	1.57	0.31	2.12	3.03	0.31	0.98	1.18	1.57	0.33
	SAE12	mm	70	85	40	8	54	77	8	25	30	40	8,5
		in	2.75	3.35	1.57	0.31	2.12	3.03	0.31	0.98	1.18	1.57	0.33

Cavity	Ports	A	B	C	E	F	G	H	I	L	M	Z	
SAE 16/2	G 1/2	mm	80	90	50	10	60	80	10	25	35	45	10,5
		in	3.15	3.54	1.97	0.39	2.36	3.15	0.39	0.98	1.38	1.77	0.41
	G 3/4	mm	80	90	50	10	60	80	10	25	35	45	10,5
		in	3.15	3.54	1.97	0.39	2.36	3.15	0.39	0.98	1.38	1.77	0.41
	G 1	mm	85	100	60	10	65	90	10	23,5	40	45	10,5
		in	3.35	3.94	2.36	0.39	2.56	3.54	0.39	0.92	1.57	1.77	0.41
	SAE12	mm	80	90	50	10	60	80	10	25	35	45	10,5
		in	3.15	3.54	1.97	0.39	2.36	3.15	0.39	0.98	1.38	1.77	0.41
	SAE16	mm	80	100	50	10	60	90	10	25	35	45	10,5
		in	3.15	3.94	1.97	0.39	2.36	3.54	0.39	0.98	1.38	1.77	0.41

Order code

3/CC /- □ □ /20/□- □-1

Cavity	Ports	Materials
08	B) G 1/4	1) Aluminium
10	C) G 3/8	2) Steel
12	D) G 1/2	
16	E) G 3/4	
	F) G 1	



# 2, 3 and 4 way Valves Bodies

3 WAY BODIES

## Dimensions

Material	Max. pressure	
	bar	psi
Alluminium	210	3050
Steel	350	5100

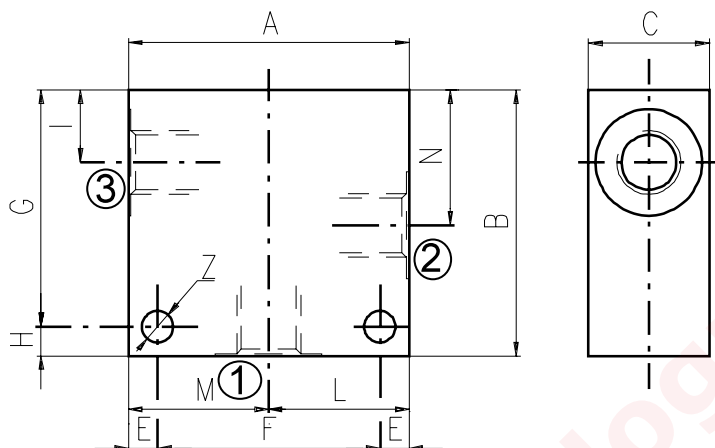

Cavity	Ports		A	B	C	E	F	G	H	I	L	M	N	Z
SAE 8/3	G 1/4	mm	60	60	30	7	46	48	12	14,8	30	30	29,1	6,5
		in	2.36	2.36	1.18	0.27	1.81	1.89	0.47	0.58	1.18	1.18	1.14	0.25
	G 3/8	mm	60	60	30	7	46	48	12	14,5	30	30	29,1	6,5
		in	2.36	2.36	1.18	0.27	1.81	1.89	0.47	0.57	1.18	1.18	1.14	0.25
	G 1/2	mm	70	65	35	7	56	53	12	14,5	35	35	29,1	6,5
		in	2.75	2.56	1.38	0.27	2.20	2.09	0.47	0.57	1.38	1.38	1.14	0.25
	SAE6	mm	60	60	30	7	46	48	12	14,5	30	30	29,1	6,5
		in	2.36	2.36	1.18	0.27	1.81	1.89	0.47	0.57	1.18	1.18	1.14	0.25
SAE 10/3	G 1/4	mm	60	65	35	6	48	59	6	18	30	30	34,5	7
		in	2.36	2.56	1.38	0.24	1.89	2.32	0.24	0.70	1.18	1.18	1.36	0.27
	G 3/8	mm	60	65	35	6	48	59	6	18,8	30	30	34,5	7
		in	2.36	2.56	1.38	0.24	1.89	2.32	0.24	0.74	1.18	1.18	1.36	0.27
	G 1/2	mm	65	70	35	6	53	64	6	18,8	32,5	32,5	34,5	7
		in	2.56	2.75	1.38	0.24	2.09	2.52	0.24	0.74	1.28	1.28	1.36	0.27
	SAE6	mm	65	70	35	6	53	64	6	18,8	32,5	32,5	34,5	7
		in	2.56	2.75	1.38	0.24	2.09	2.52	0.24	0.74	1.28	1.28	1.36	0.27
	SAE8	mm	65	70	35	6	53	64	6	18,8	32,5	32,5	34,5	7
		in	2.56	2.75	1.38	0.24	2.09	2.52	0.24	0.74	1.28	1.28	1.36	0.27
SAE 12/3	G 1/2	mm	70	100	40	8	54	92	8	25	35	35	53,5	8,5
		in	2.75	3.94	1.57	0.31	2.12	3.6	0.31	0.98	1.38	1.38	2.10	0.33
	G 3/4	mm	90	100	50	10	70	90	10	25,1	45	45	53,5	10,5
		in	3.54	3.94	1.97	0.39	2.75	3.54	0.39	0.99	1.77	1.77	2.11	0.41
	SAE10	mm	80	100	40	8	64	92	8	25	40	40	53,5	8,5
		in	3.15	3.94	1.57	0.31	2.52	3.6	0.31	0.98	1.57	1.57	2.11	0.33
	SAE12	mm	80	100	45	8	64	92	8	25	40	40	53,5	8,5
		in	3.15	3.94	1.57	0.31	2.52	3.6	0.31	0.98	1.57	1.57	2.11	0.33
SAE 16/3	G 3/4	mm	90	100	50	10	70	90	10	25,1	45	45	53,5	10,5
		in	3.54	3.94	1.97	0.39	2.75	3.54	0.39	0.99	1.77	1.77	2.11	0.41
	SAE12	mm	90	105	50	10	70	95	10	25,1	45	45	53,5	10,5
		in	3.54	4.13	1.97	0.39	2.75	3.74	0.39	0.99	1.77	1.77	2.11	0.41
	SAE16	mm	90	105	50	10	70	95	10	25,1	45	45	53,5	10,5
		in	3.54	4.13	1.97	0.39	2.75	3.74	0.39	0.99	1.77	1.77	2.11	0.41

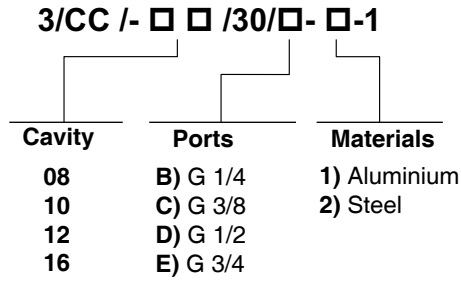

see SAE cartridges catalogue

# 2, 3 and 4 way Valves Bodies

4 WAY BODIES

## Dimensions

Material	Max. pressure	
	bar	psi
Aluminium	210	3050
Steel	350	5100

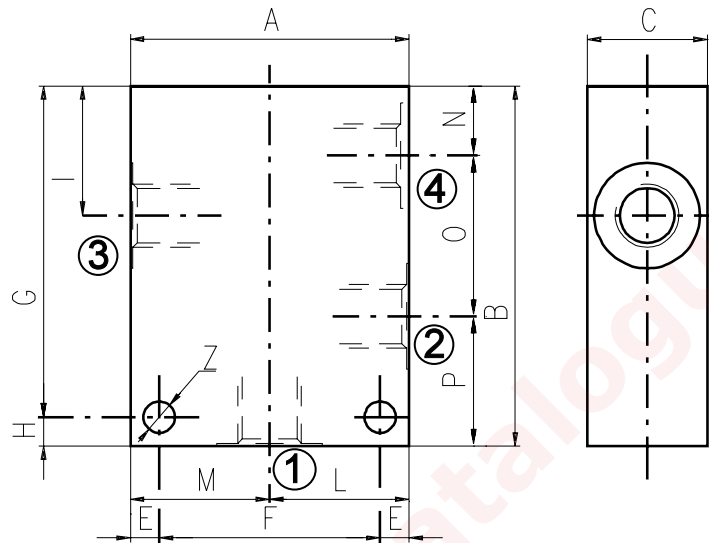

Cavity	Ports	A	B	C	E	F	G	H	I	L	M	N	O	P	Z	
SAE 8/4	G 1/4	mm	60	75	30	7	46	63	12	29,1	30	30	14,8	29,1	31,1	6,5
		in	2.36	2.95	1.18	0.27	1.81	2.48	0.47	1.14	1.18	1.18	0.58	1.14	1.22	0.25
	SAE6	mm	60	75	30	7	46	63	12	29,1	30	30	14,8	29,1	31,1	6,5
		in	2.36	2.95	1.18	0.27	1.81	2.48	0.47	1.14	1.18	1.18	0.58	1.14	1.22	0.25
SAE 10/4	G 3/8	mm	60	85	35	6	48	79	6	34,5	30	30	18,8	31,7	34,5	7
		in	2.36	3.35	1.38	0.24	1.89	3.11	0.24	1.36	1.18	1.18	0.74	1.25	1.36	0.27
	G 1/2	mm	70	85	35	6	58	79	6	34,5	35	35	18,8	31,7	34,5	7
		in	2.75	3.35	1.38	0.24	2.28	3.11	0.24	1.36	1.38	1.38	0.74	1.25	1.36	0.27
	SAE6	mm	60	85	35	6	48	79	6	34,5	30	30	18,8	31,7	34,5	7
		in	2.45	3.35	1.38	0.24	1.89	3.11	0.24	1.36	1.18	1.18	0.74	1.25	1.36	0.27
	SAE8	mm	70	85	35	6	58	79	6	34,5	35	35	18,8	31,7	34,5	7
		in	2.75	3.35	1.38	0.24	2.28	3.11	0.24	1.36	1.38	1.38	0.74	1.25	1.36	0.27
SAE 12/4	G 1/2	mm	80	115	40	8	64	107	8	44	40	40	22	44,5	48,5	8,5
		in	3.15	4.53	1.57	0.31	2.52	4.21	0.31	1.73	1.57	1.57	0.87	1.75	1.9	0.33
	SAE10	mm	80	115	40	8	64	107	8	44	40	40	22	44,5	48,5	8,5
		in	3.15	4.53	1.57	0.31	2.52	4.21	0.31	1.73	1.57	1.57	0.87	1.75	1.9	0.33
SAE 16/4	G 3/4	mm	100	130	50	10	80	120	10	53,5	50	50	25,1	56,9	48	10,5
		in	3.94	5.12	1.97	0.39	3.15	4.72	0.39	2.11	1.97	1.97	0.99	2.24	1.89	0.41

3/CC /- □ □ /40/□- □-1

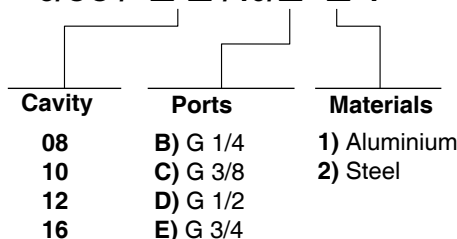

## How to order valves with body

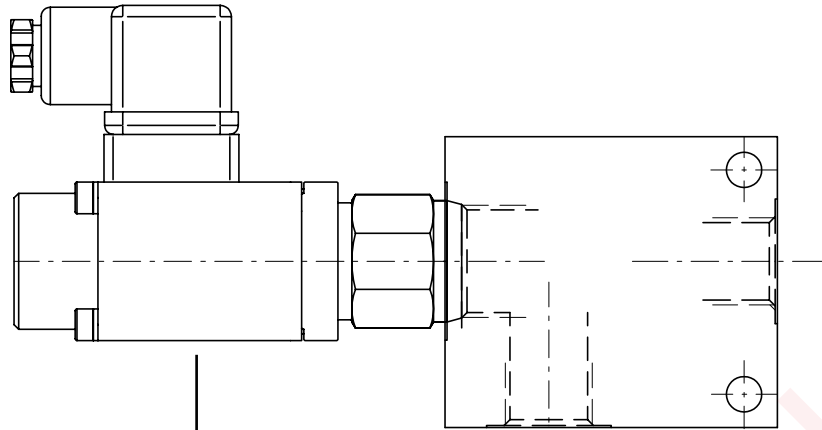

**CARTRIDGE CODE**

**MP-10-Y/0-4-1V/**

**BILLET CODE**

**C- 1-1**

Cavity	Ports	Materials
08	B) G 1/4	1) Aluminium
10	C) G 3/8	
12	D) G 1/2	
16	E) G 3/4	
	F) G 1	
	J) SAE 6	2) Steel
	K) SAE 8	
	L) SAE 10	
	M) SAE 12	
	N) SAE 16	

## Dimensions

VARIATION "A": the dimensions with "★" are related to the variation "A". Features of variation "A" are required only if noted on specific product catalogue page.

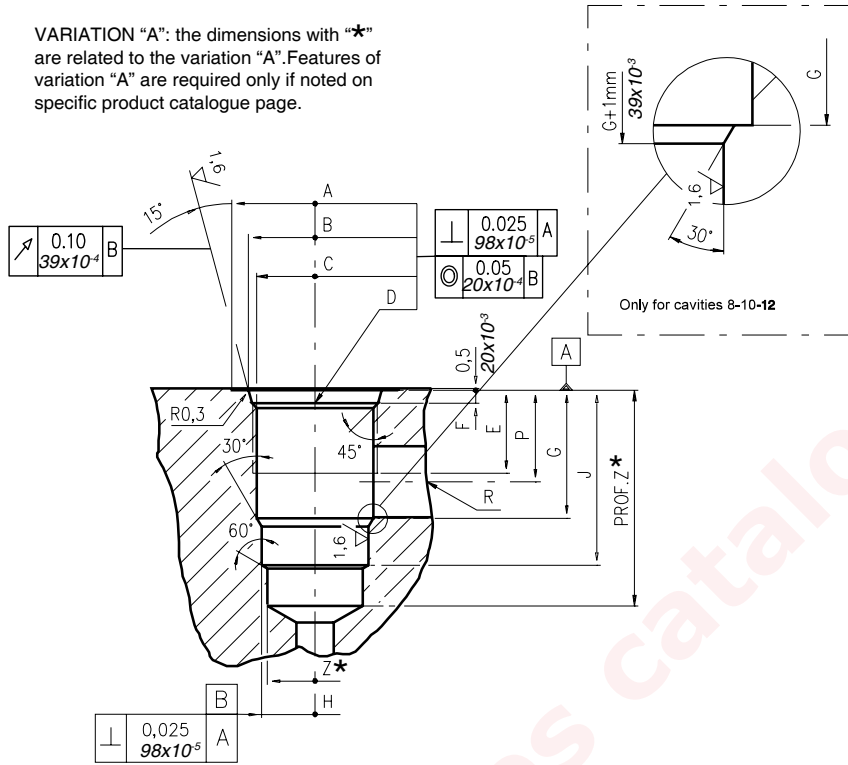

\		A	B ±0,05	C ±0,05	D	E	F	G	H ±0,02	J	K ±0,02	L	M ±0,02	N	P	R øMAX	S øMAX	T øMAX	U	V øMAX	X øMAX	Z ★ øMIN	Prof.Z MIN★
		08/2	mm	27	20,66	17,42	3/4-16 UNF	12,50	2,50	18,20	12,72	29,50	-	-	-	-	14,00	8,00	-	-	-	-	-
	in	1.06	0.81	0.68	UNF	0.49	0.10	0.72	0.50	1.16					0.55	0.31						0.47	1.53
10/2	mm	30	24,00	20,62	7/8-14 UNF	16,00	2,80	24,00	15,90	33,50	-	-	-	-	18,30	11,00	-	-	-	-	-	14,50	40
	in	1.18	0.94	0.81	UNF	0.63	0.11	0.94	0.62	1.32					0.72	0.43						0.57	1.57
12/2	mm	38	29,23	24,73	1 1/16-12 UNF	19,00	3,50	34,15	22,25	46,80	-	-	-	-	24,50	19,00	-	-	-	-	-	21,50	60
	in	1.50	1.15	0.97	UNF	0.75	0.14	1.34	0.87	1.84					0.96	0.75						0.85	2.36
16/2	mm	45	35,58	31,34	1 5/16-12 UNF	22,00	3,50	34,00	28,62	47,00	-	-	-	-	24,50	19,00	-	-	-	-	-	25,50	70
	in	1.77	1.40	1.23	UNF	0.87	0.14	1.34	1.13	1.85					0.96	0.75						1.00	2.75

Rougher tool

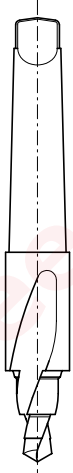

Cavity	Code number
08/2	3UT00053190
10/2	3UT00056610
12/2	3UT00054090
16/2	3UT00054510

Finisher tool

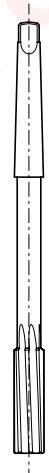

Cavity	Code number
08/2	3UT06A1270N
10/2	3UT00054580
12/2	3UT00054670
16/2	3UT00054520

Tap

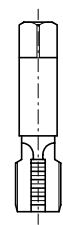

Cavity	Code number
08/2	3UT03416UNF
10/2	3UT07814UNF
12/2	3UT0111612UN
16/2	3UT0151612UN

Cavity plugs

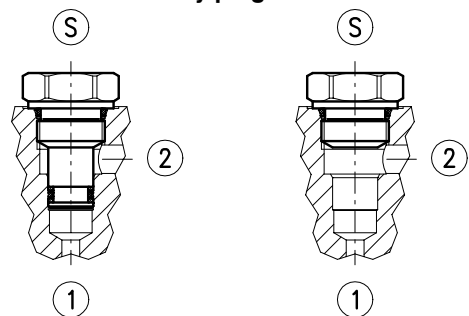

Cavity	Code number	①	②	Ⓢ
08/2	3XTP3533700	X	X	X
	4TP5531500	0	0	X
10/2	3XTP3544200	X	X	X
	3XTP1542300	0	0	X
12/2	3XTP3555400	X	X	X
	3XTP1552900	0	0	X
16/2	3XTP3575500	X	X	X
	3XTP1572900	0	0	X

X=Closed 0=Open

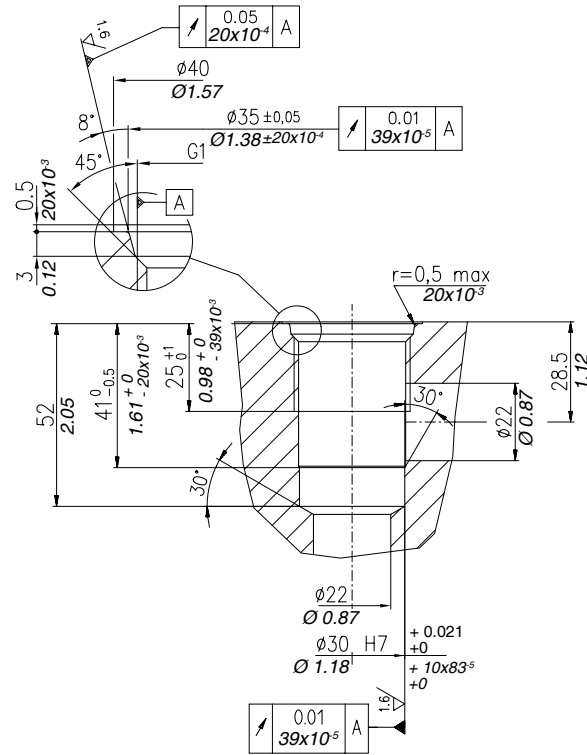

**Rougher tool**  
Cod.3UT00050870A

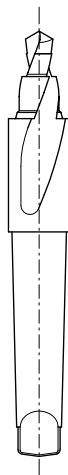

**Finisher tool**  
Cod.3UTO6A3000N



**Tap**  
Cod.3UT09A10F11G



## Dimensions

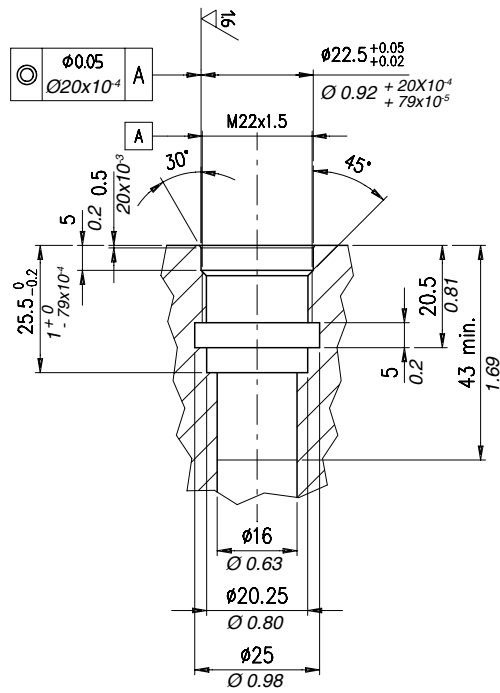

**Rougher tool**  
Code 3UT00054660

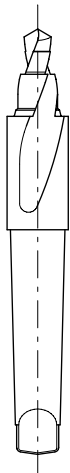

**Finisher tool**  
Code 3UT00055530



**Tap**  
Code 3UT08A22F150



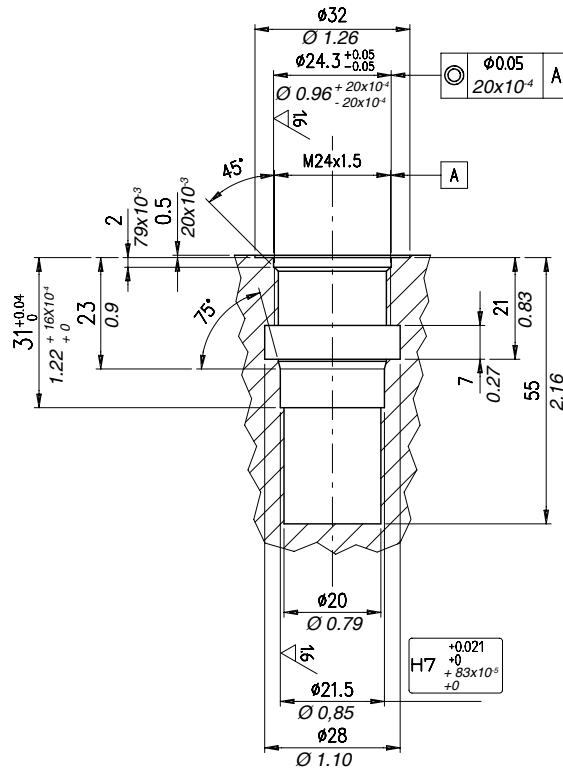

Rougher tool

Code 3UT00052210

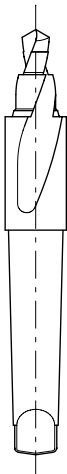

Finisher tool

Code 3UT00055030

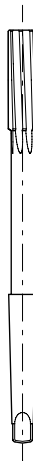

Tap

Code 3UT08A24F150





## Dimensions

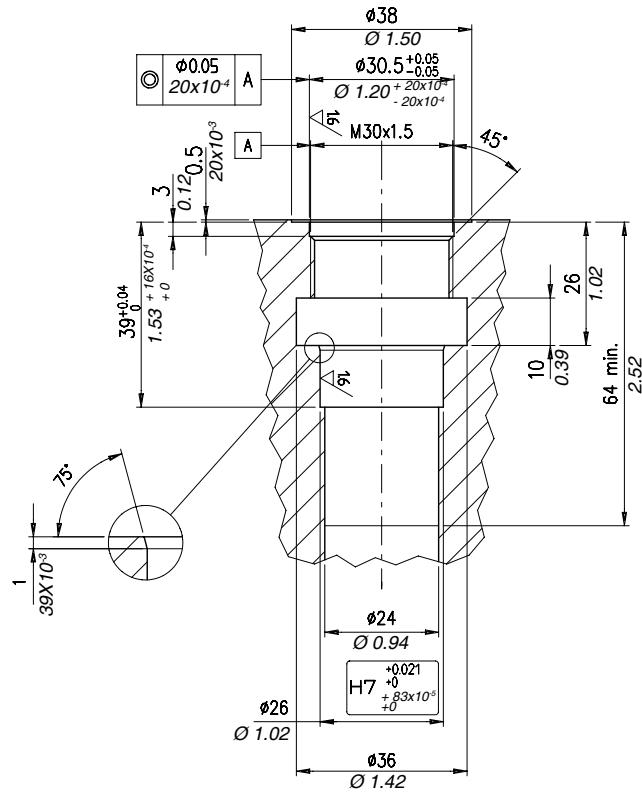

**Rougher tool**  
Code 3UT00052200

**Finisher tool**  
Code 3UT06A2600P

**Tap**  
Code 3UT08A30F150

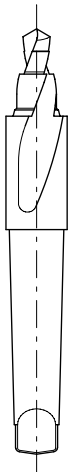

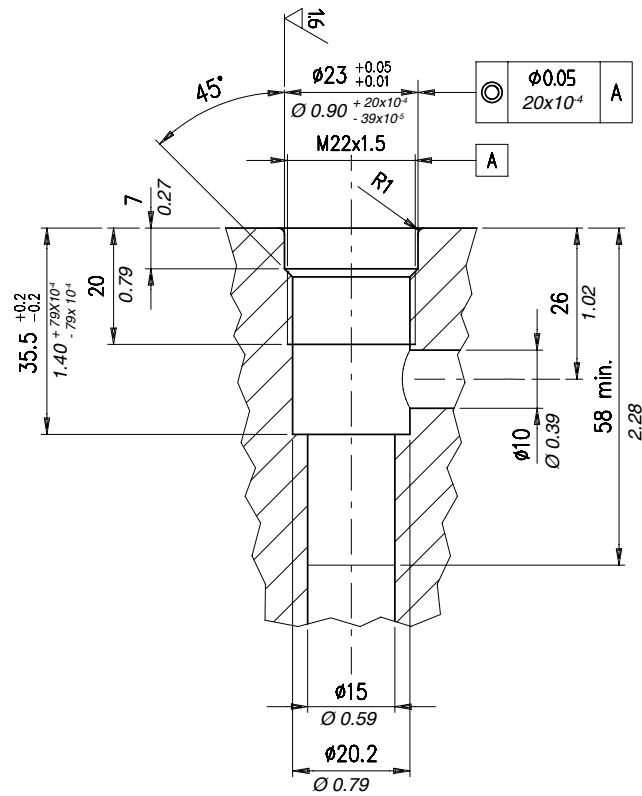

**Rougher tool**  
Code 3UT00055540

**Finisher tool**  
Code 3UT06A2300N

**Tap**  
Code 3UT08A22F150

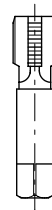
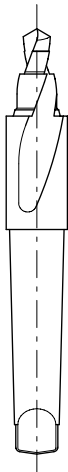

## Dimensions

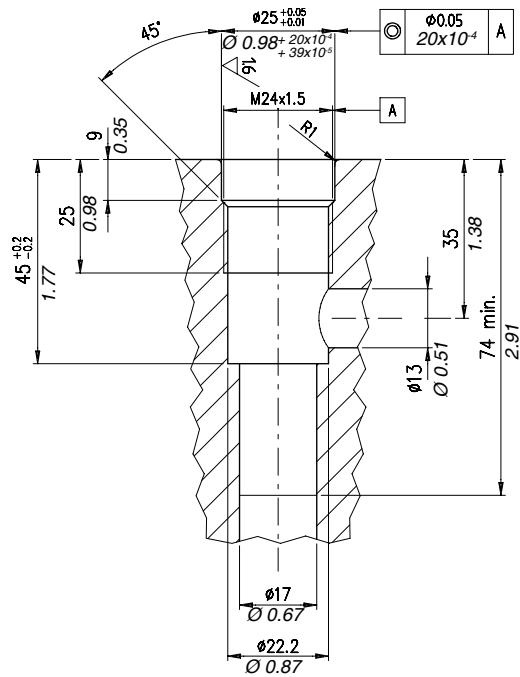

**Rougher tool**  
Code 3UT00055550

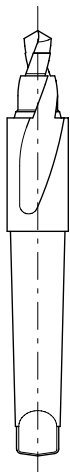

**Finisher tool**  
Code 3UT06A2500N



**Tap**  
Code 3UT08A24F150



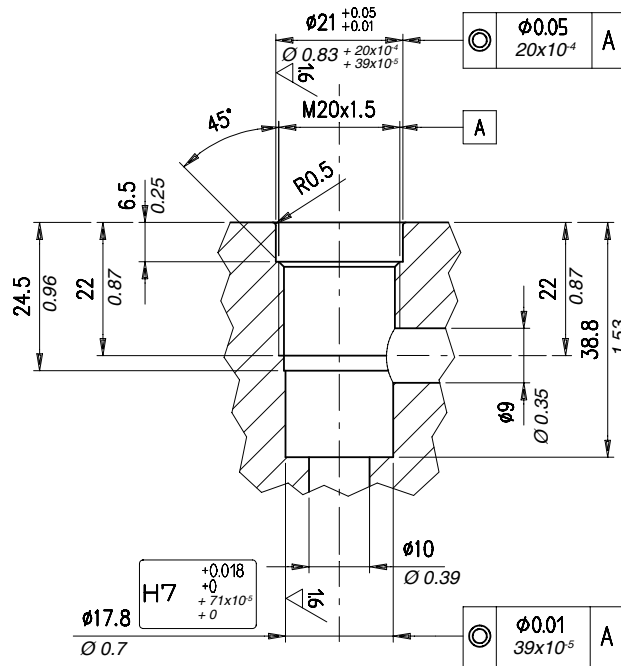

Rougher tool  
Code 3UT00050050

Finisher tool  
Code 3UT00055040

Tap  
Code 3UT08A20F150

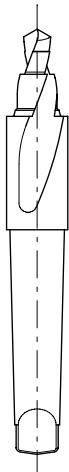

## Dimensions

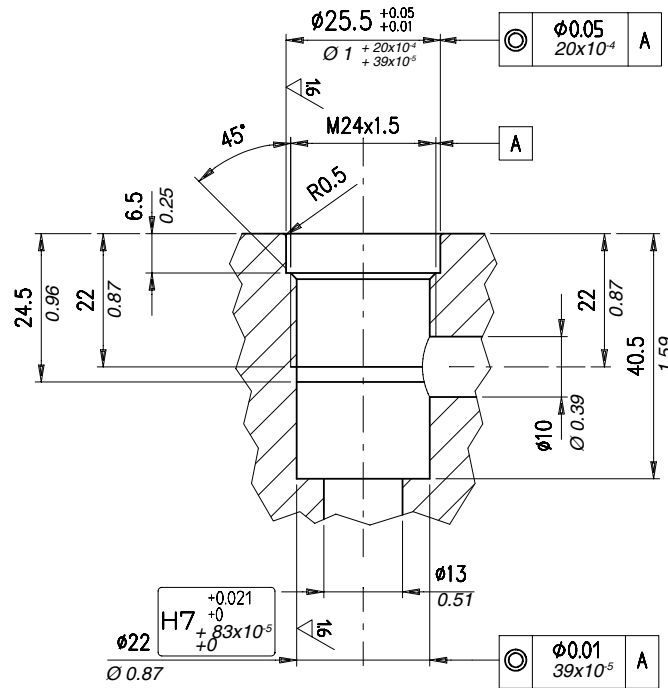

**Rougher tool**  
Code 3UT00050070

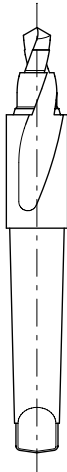

**Finisher tool**  
Code 3UT06A22000P



**Tap**  
Code 3UT08A24F150

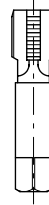

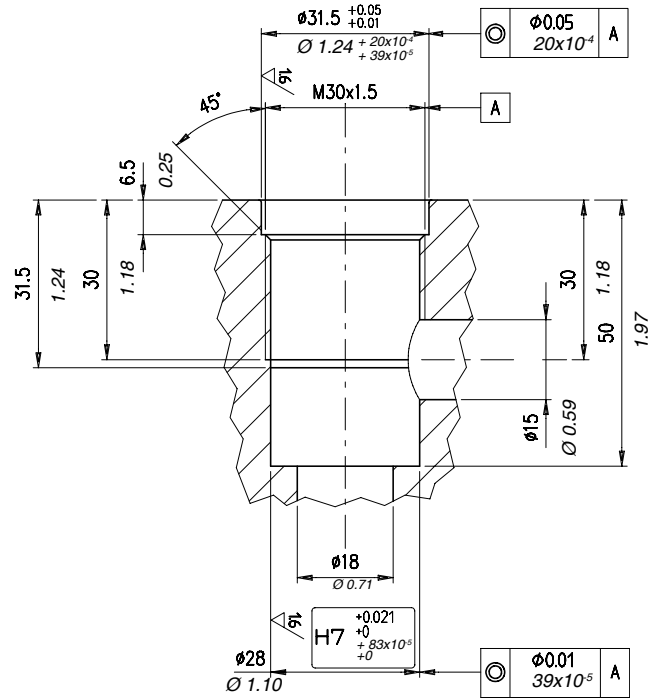

**Rougher tool**  
Code 3UT00050070

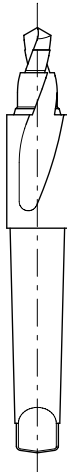

**Finisher tool**  
Code 3UT06A22000P



**Tap**  
Code 3UT08A24F150



## Dimensions

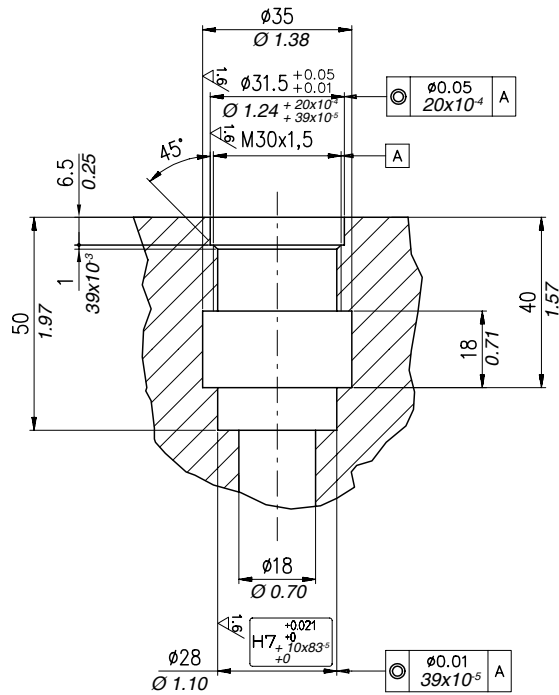

Rougher tool

Code 3UT00050070

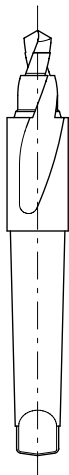

Finisher tool

Code 3UT06A22000P



Tap

Code 3UT08A24F150







1<sup>st</sup> edition May 2010

[WWW.WALVOIL.COM](http://WWW.WALVOIL.COM)



D1WWEM01E

