

CARATTERISTICHE

Luce nominale	DN 12
Portata min/max	1/80 l/min - 0.26/21.1 GPM
Pressione di lavoro max.	350 bar - 5075 PSI
Temperatura ambiente	-30°C + 50°C
Temperatura olio	-30°C + 80°C
Filtraggio consigliato	50 micron
Coppia di serraggio	145÷158 Nm
Peso	0.179 Kg

PERFORMANCE

Rated size
Min/max flow-rate
Max working pressure
Room temperature
Oil temperature
Recommended filtration
Tightening torque
Weight

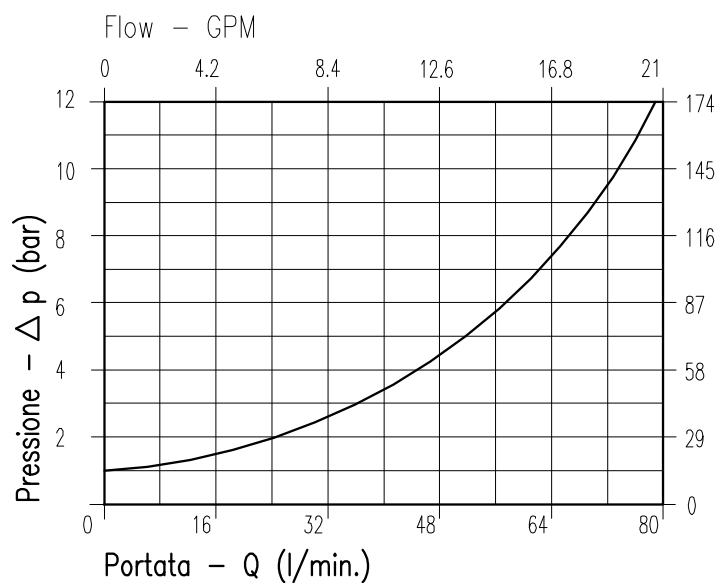

Viscosità olio 46 cSt a 50°C
Oil viscosity 46 cSt at 50°C

VALVOLA DI BLOCCO A CARTUCCIA
CARTRIDGE CHECK VALVE

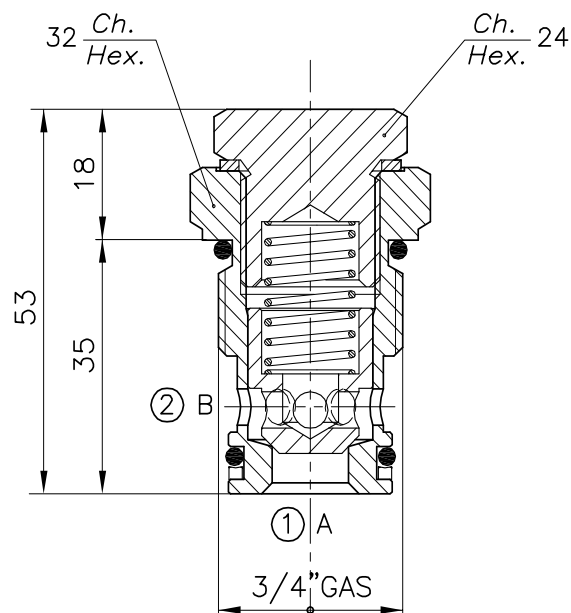

CAVITA'
CAVITY **CE.008.N**

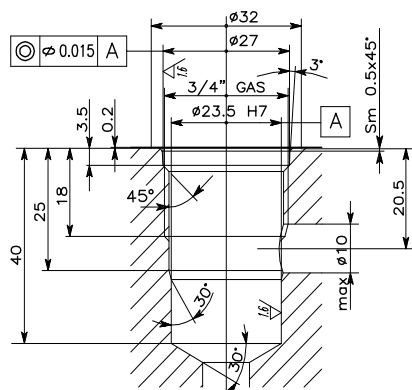

Si raccomanda l'esatta esecuzione della sede
The valve seat should be perfectly tooled

CODICE DI ORDINAZIONE
HOW TO ORDER

003 035 0 J 0

Inizio apertura Cracking pressure	
J	1 bar Molla (colore nero) Spring (black)
W	6÷8 bar Molla (colore giallo) Spring (yellow)