

VNR-C-34-100-...

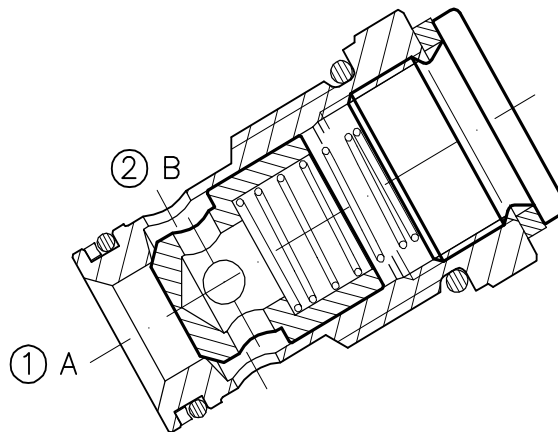
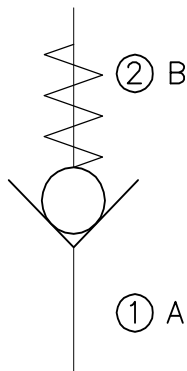

CARATTERISTICHE

Luce nominale	DN 16
Portata min/max	1/150 l/min - 0.26/39.6 GPM
Pressione di lavoro max.	350 bar - 5075 PSI
Temperatura ambiente	-30°C + 50°C
Temperatura olio	-30°C + 80°C
Filtraggio consigliato	50 micron
Coppia di serraggio	148÷158 Nm
Peso	0.292 Kg

PERFORMANCE

Rated size
Min/max flow-rate
Max working pressure
Room temperature
Oil temperature
Recommended filtration
Tightening torque
Weight

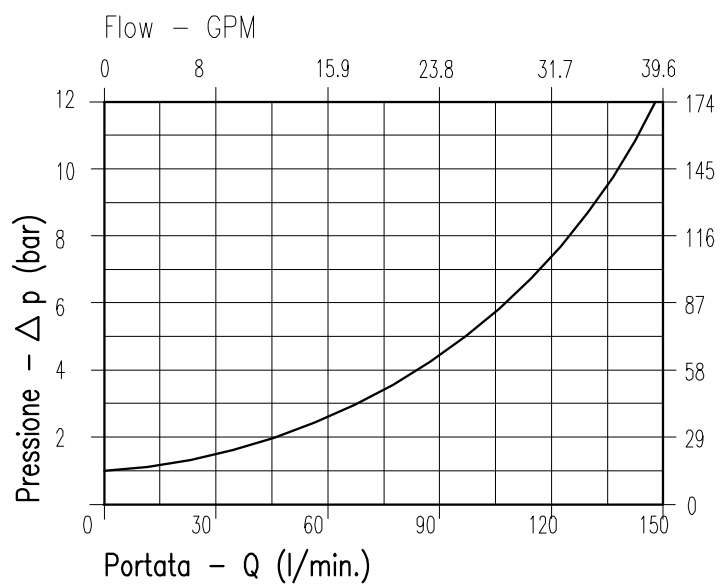

Viscosità olio 46 cSt a 50°C
Oil viscosity 46 cSt at 50°C

VALVOLA DI BLOCCO A CARTUCCIA
CARTRIDGE CHECK VALVE

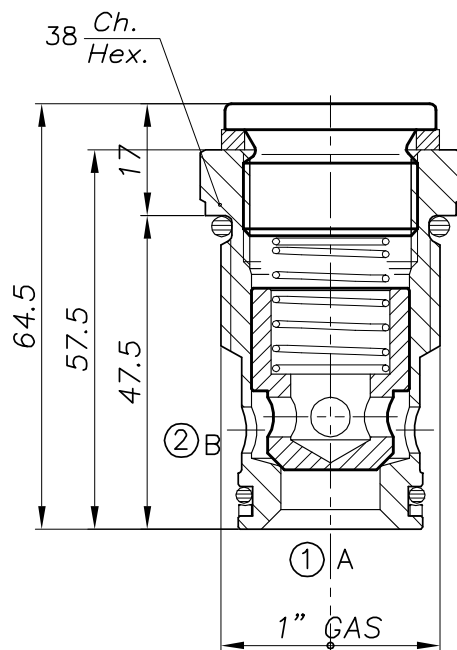

CAVITA' CAVITY CE.065.N

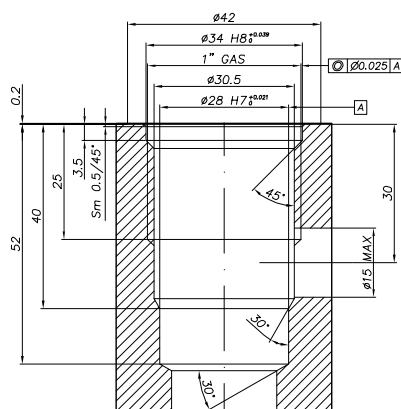

Si raccomanda l'esatta esecuzione della sede
 The valve seat should be perfectly tooled

CODICE DI ORDINAZIONE
HOW TO ORDER

003 155 0 J 0

Inizio apertura
 Cracking pressure

J 1 bar
 Molle (colore nero)
 Spring (black)

W 6÷8 bar
 Molle (colore giallo)
 Spring (yellow)