

VNR-C-SE-071N-78UNF-...

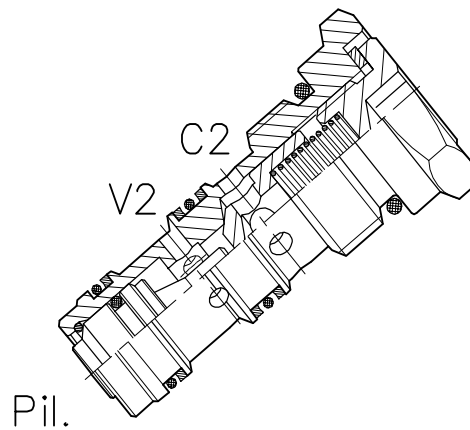
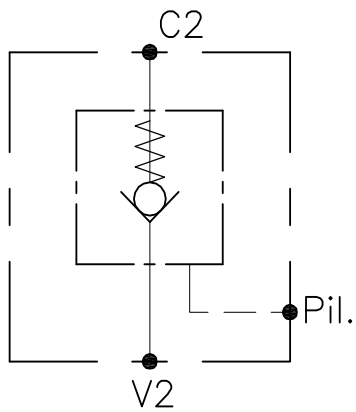

CARATTERISTICHE

Luce nominale	DN 8
Portata min/max	1/45 l/min - 0.26/11.9 GPM
Pressione di lavoro max.	350 bar - 5075 PSI
Rapporto di pilotaggio	3 : 1
Temperatura ambiente	-30°C + 50°C
Temperatura olio	-30°C + 80°C
Filtraggio consigliato	50 micron
Coppia di serraggio	50±59 Nm
Peso	0.122 Kg

PERFORMANCE

Rated size
Min/max flow-rate
Max working pressure
Pilot ratio
Room temperature
Oil temperature
Recommended filtration
Tightening torque
Weight

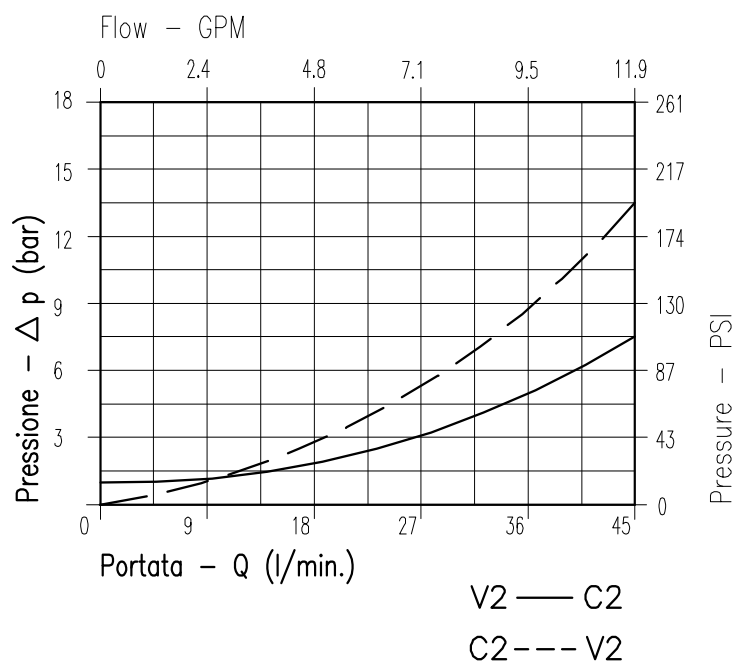

Viscosità olio 46 cSt a 50°C - Oil viscosity 46 cSt at 50°C

VALVOLA DI BLOCCO PILOTATA A CARTUCCIA
CARTRIDGE PILOT CHECK VALVE

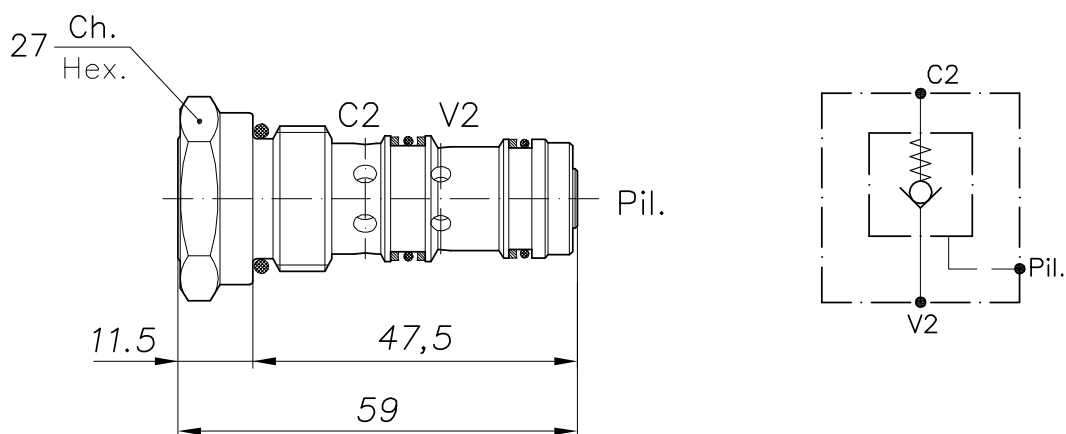

CAVITA' CAVITY CE.071.N

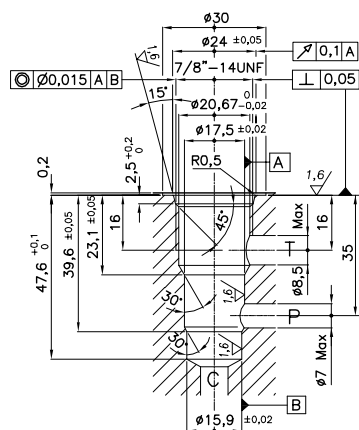

Si raccomanda l'esatta esecuzione della sede
 The valve seat should be perfectly tooled

CODICE DI ORDINAZIONE
HOW TO ORDER

003 335 0 J 0

Inizio apertura Cracking pressure	
J	1 bar Molla (colore nero) Spring (black)
Z	3-4 bar Molla (colore verde) Spring (green)
W	6-8 bar Molla (colore giallo) Spring (yellow)