



# Counterbalance valves

# COUNTERBALANCE VALVES

## Index

Hydraulic diagram	Type	Description	Maximum flow up		Maximum pressure		Page
			l/min	US gpm	bar	psi	
	VOSLP/A	Single counterbalance valves, external pilot operated type, line mounting, cartridge construction. Equipped with connection for hydraulic brake release	180	48	350	5100	35

**Operation**

The oil flow is allowed from D1 to U1 and is stopped in the opposite way (from U1 to D1) up to the spring setting value. Free oil flow from U1 to D1 is strictly possible when the pilot pressure in P is strong enough to pilot the valve poppet.

Use the following formula to assert the applicable pilot pressure:

**(valve setting - load pressure) / pilot ratio = pilot pressure**

For example: if your pilot ratio is 1:4, your setting pressure is 250 bar (3600 psi) and your load pressure is 130 bar (1900 psi) then you will need 30 bar (430 psi) pilot pressure in order to displace the load  $[(250 \text{ bar} - 3600 \text{ psi} - 130 \text{ bar} - 1900 \text{ psi}) / 4 = 30 \text{ bar} - 430 \text{ psi}]$ .

Should counterpressure arise in D1, the setting value of valve poppet (1:1 ratio) will increase and the pilot pressure be negatively affected (1:1 ratio).

Lack of overcenter stability and troublesome motion even after complete valve assembly, will suggest that the valve

application may require a PG version. Please contact our technical service for action. Use of a special shuttle valve allows for release of hydraulic parking brakes.

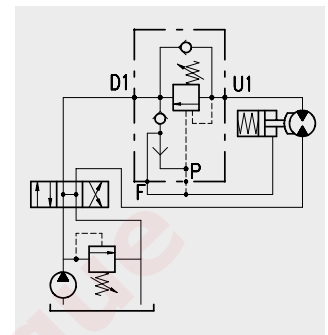

**Performance**

**Body Valves**

Type	Max. flow		Max. pressure		Application range with standard springs	Oil leakage from U1 to D1	Pilot ratio	Weight	
	l/min	US gpm	bar	psi				kg	lb
VOSLP/A 38*	35	9.2	350	5100	5-210 bar-72.5÷3050 psi (test setting: 170 bar-2500 psi at 5 l/min.-1.3 US gpm)  50÷350 bar-725÷5100 psi (test setting 280 bar-4100 psi at 5 l/min.-1.3 US gpm)  100÷700 bar-1450÷10150 psi (test setting 350 bar-5100 psi at 5 l/min.-1.3 US gpm)	0,25 cm³/min -15x10 <sup>-3</sup> in³/min (5 drops) at 210 bar-3050 psi and 80% of the spring setting value with oil viscosity of 46 cSt.	1:3 (standard type)	1,16	2,56
aluminium									
VOSLP/A 12**	70	18					1:4 (on request only)	1,87	4,12
								steel	
VOSLP/A 34***	100	26	1:3 (standard type)	1,37	3,02				
				aluminium					
VOSLP/A 100***	180	47	1:7 (on request only)	2,26	4,98				
				steel					
				2,30	5,07				
				aluminium					
steel		3,80	8,38						
aluminium		6,70	14,77						
steel		9,89	21,80						

Overcenter cartridge: \*VMPD 38 - \*\*VMPD12 - \*\*\*VMPD34

# Type VOSLP/A 38

Single overcenter valve, external pilot operated type, line mounting, cartridge construction. Equipped with connection for hydraulic brake release

## Dimensions and hydraulic circuit

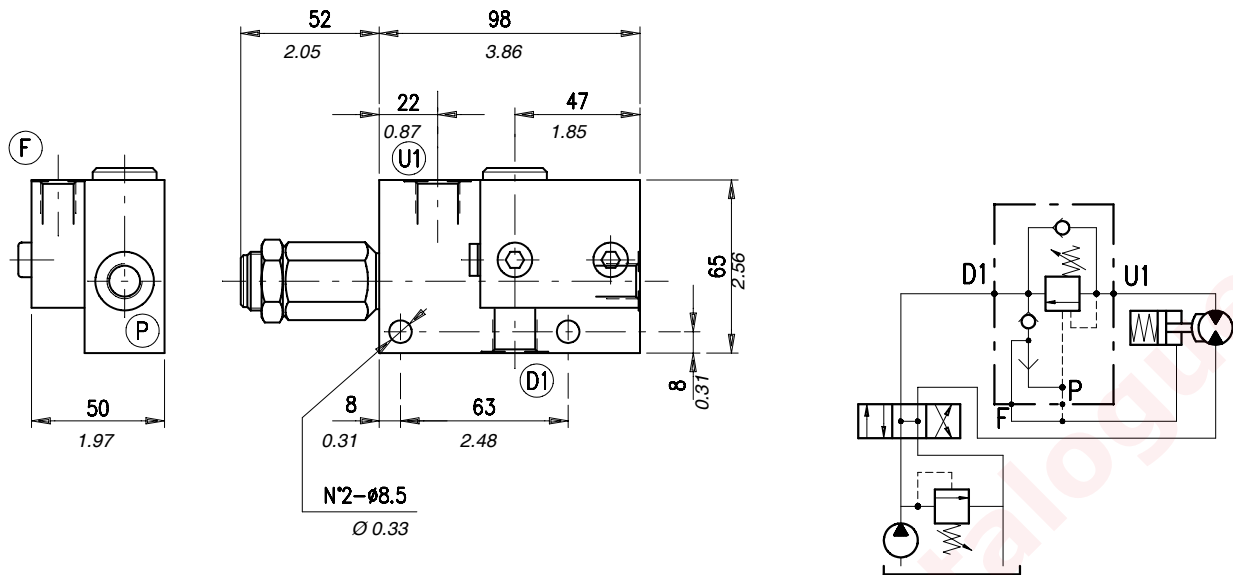

D1-U1	F-P
G 3/8	G 1/4

## Rating diagrams

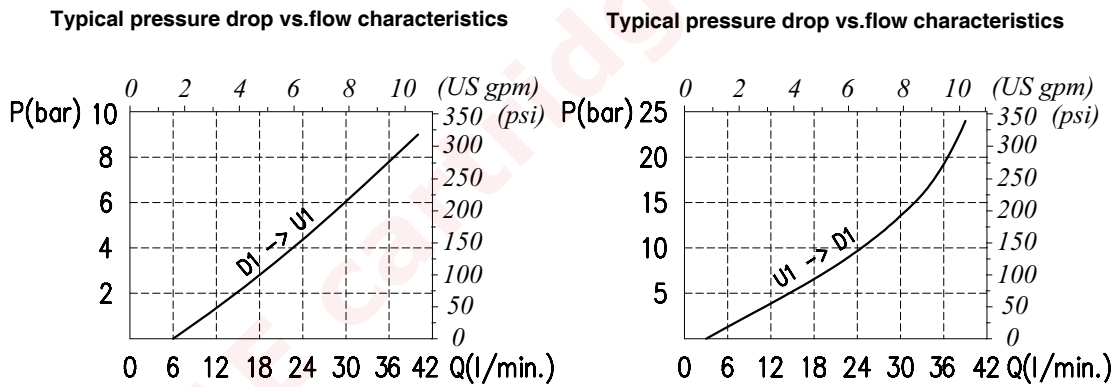

## Order code

VOSLP / A 38 / □ . S . □□ . □□ . □□ / □□

Pressure settings

Pilot ratio

Type of pilot

Check valve seat

Body material

**TS** 5÷210 bar (72.5÷3050 psi)  
**TR** 50÷350 bar (725÷5100 psi)  
 (Standard)

**p3** 1:2,8 (Standard)  
**p4** 1:4

**PG** Without damper (standard)  
 With damper

**VRR** See body  
 Hardened steel

**ac** Aluminium  
**Steel**

**TG** 100÷700 bar (1450÷10150 psi)

**Dimensions and hydraulic circuit**

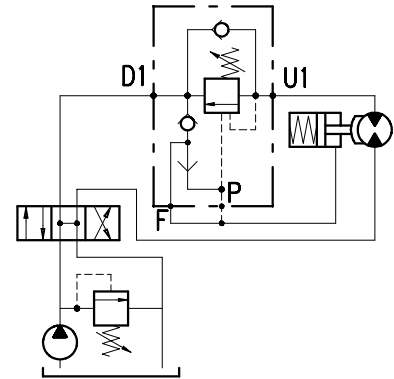
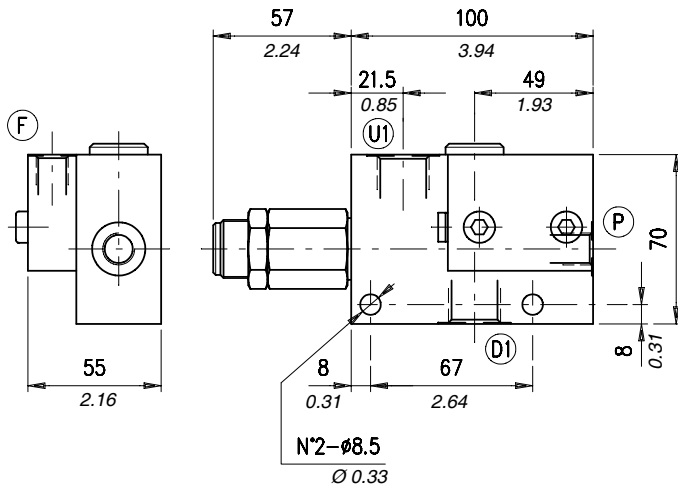

D1-U1	F-P
G 1/2	G 1/4

**Rating diagrams**

Typical pressure drop vs. flow characteristics

Typical pressure drop vs. flow characteristics

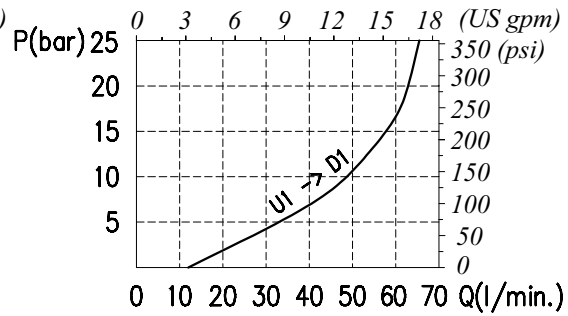
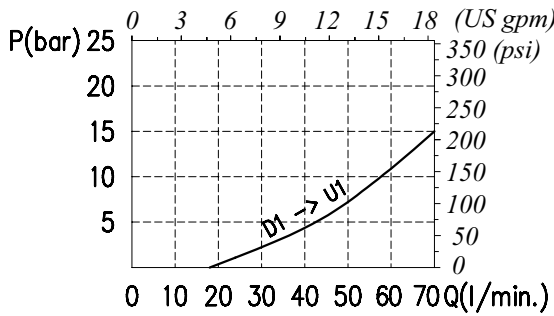

**Order code**

VOSLP /A 12 / □□ . S . □□ . □□ . □□ / □□

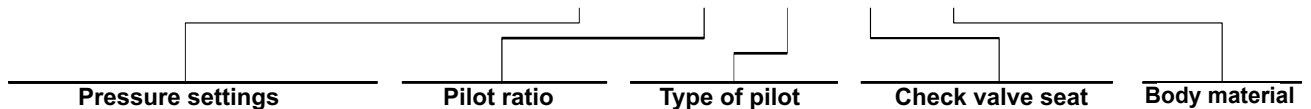

**TS** 5÷210 bar (72.5÷3050 psi)  
**TR** 50÷350 bar (725÷5100 psi) (Standard)  
**TG** 100÷700 bar (1450÷10150 psi)

**p3** 1:3 (Standard)  
**p4** 1:4

**PG** With damper  
 \_ Without damper (Standard)

**VRR** Hardened steel  
 \_ See body

**ac** Steel  
 \_ Aluminium

# Type VOSLP/A 34 (100)

Single overcenter valve, external pilot operated type, line mounting, cartridge construction. Equipped with connection for hydraulic brake release

## Dimensions and hydraulic circuit

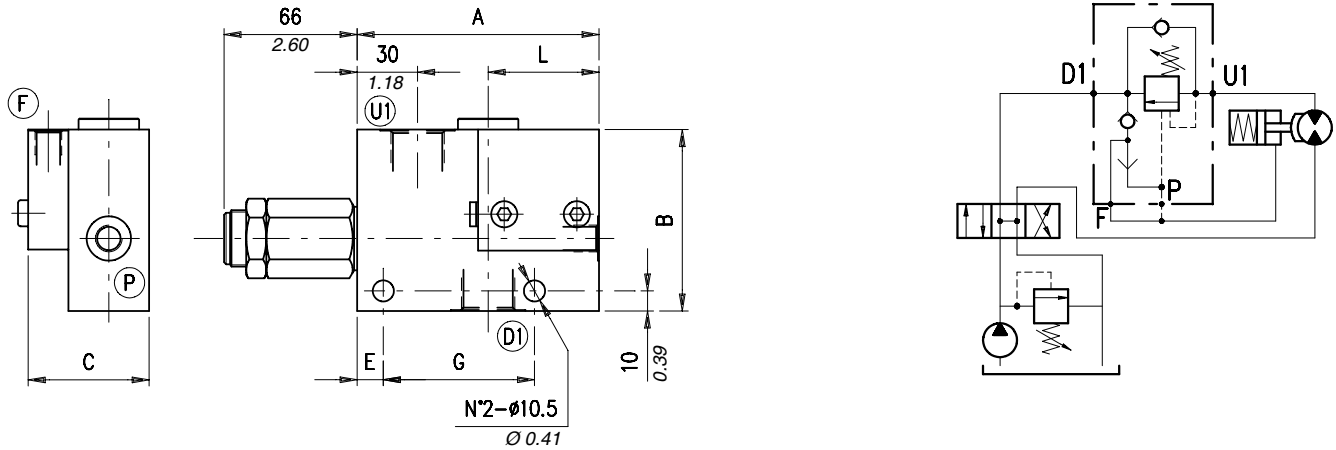

VOSLP/A	D1-U1	F-P	A*	B*	C*	E*	G*	L*
34	G 3/4	G 1/4	120 - 4.72	90 - 3.54	60 - 2.36	13 - 0.51	75 - 2.95	55 - 2.16
100	G 1	G 1/4	140 - 5.51	100 - 3.94	80 - 3.15	10 - 0.39	100 - 3.94	64 - 2.52

\* Dimensions are in mm - in

## Rating diagrams

Typical pressure drop vs. flow characteristics

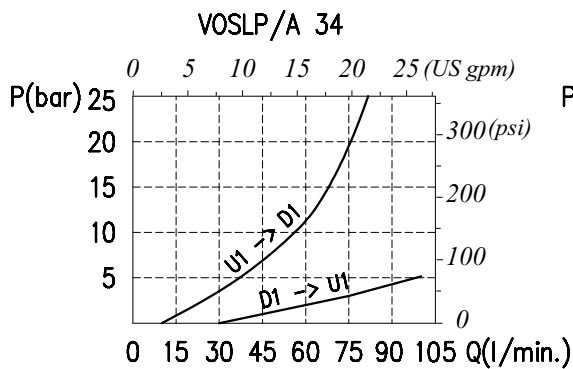

Typical pressure drop vs. flow characteristics

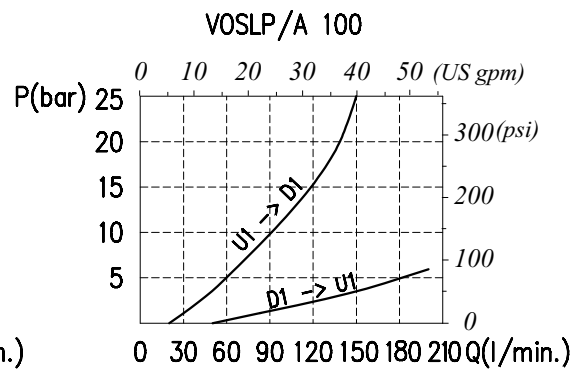

## Order code

VOSLP / A □□ / □□ . S . □□ . □□ . □□ / □□

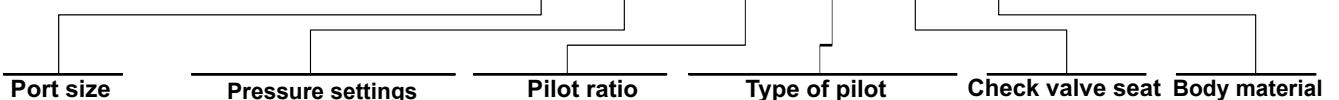

<b>34)</b> G 3/4	<b>TS)</b> 5÷210 bar (72.5÷3050 psi)	<b>p3)</b> 1:3	— Without damper	See body	— Aluminium
<b>100)</b> G 1	<b>TR)</b> 50÷350 bar (725÷5100 psi)	(Standard)	(Standard)	<b>VRR)</b> Hardened steel	<b>ac</b> Steel
	<b>TG)</b> 100÷700 bar (1450÷10150 psi)	<b>p7)</b> 1:7	<b>PG)</b> With damper		

Material	Max. pressure	
	bar	psi
Alluminium	210	3050
Steel	350	5100

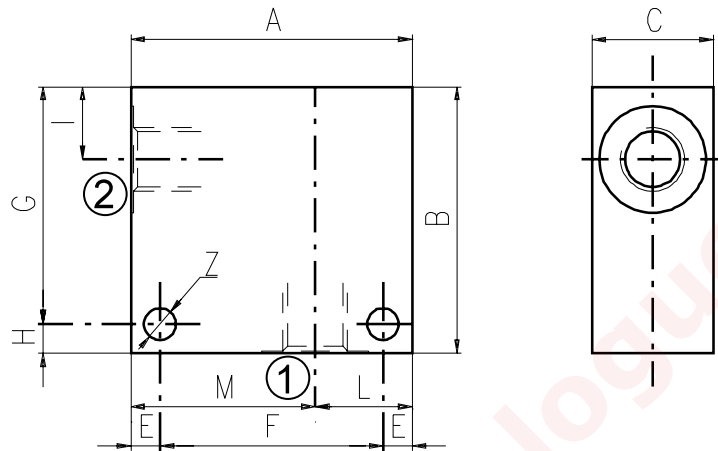

Cavity	Ports		A	B	C	E	F	G	H	I	L	M	Z
SAE 8/2	G 1/2	mm	70	65	35	7	56	53	12	14,5	35	35	6,5
		in	2.75	2.56	1.38	0.27	2.20	2.09	0.47	0.57	1.38	1.38	0.25
	G 1/4	mm	50	50	30	6	38	44	6	14,8	20	30	6,5
		in	1.97	1.97	1.18	0.24	1.50	1.73	0.24	0.58	0.79	1.18	0.25
	G 3/8	mm	50	50	30	6	38	44	6	14,8	20	30	6,5
		in	1.97	1.97	1.18	0.24	1.50	1.73	0.24	0.58	0.79	1.18	0.25
	SAE6	mm	50	50	30	6	38	44	6	14,8	20	30	6,5
		in	1.97	1.97	1.18	0.24	1.50	1.73	0.24	0.58	0.79	1.18	0.25
SAE 10/2	G 1/4	mm	60	60	35	6	48	54	6	18,8	25	35	6,5
		in	2.36	2.36	1.38	0.24	1.89	2.12	0.24	0.74	0.98	1.38	0.25
	G 3/8	mm	60	60	35	6	48	54	6	18,8	25	35	6,5
		in	2.36	2.36	1.38	0.24	1.89	2.12	0.24	0.74	0.98	1.38	0.25
	G 1/2	mm	60	60	35	6	48	54	6	18,8	25	35	6,5
		in	2.36	2.36	1.38	0.24	1.89	2.12	0.24	0.74	0.98	1.38	0.25
	SAE8	mm	60	70	35	6	48	64	6	18,8	25	35	6,5
		in	2.36	2.75	1.38	0.24	1.89	2.52	0.24	0.74	0.98	1.38	0.25
	SAE10	mm	70	70	35	6	58	64	6	18,5	35	35	6,5
		in	2.75	2.75	1.38	0.24	2.28	2.52	0.24	0.73	1.38	1.38	0.25
	SAE12	mm	70	70	40	8	54	62	8	22	30	40	8,5
		in	2.75	2.75	1.57	0.31	2.12	2.44	0.31	0.87	1.18	1.57	0.33
SAE 12/2	G 1/2	mm	70	80	40	8	54	72	8	25	30	40	8,5
		in	2.75	3.15	1.57	0.31	2.12	2.83	0.31	0.98	1.18	1.57	0.33
	G 3/4	mm	70	90	40	8	54	82	8	25	30	40	8,5
		in	2.75	3.54	1.57	0.31	2.12	3.23	0.31	0.98	1.18	1.57	0.33
	SAE10	mm	70	85	40	8	54	77	8	25	30	40	8,5
		in	2.75	3.35	1.57	0.31	2.12	3.03	0.31	0.98	1.18	1.57	0.33
	SAE12	mm	70	85	40	8	54	77	8	25	30	40	8,5
		in	2.75	3.35	1.57	0.31	2.12	3.03	0.31	0.98	1.18	1.57	0.33

Cavity	Ports	A	B	C	E	F	G	H	I	L	M	Z	
SAE 16/2	G 1/2	mm	80	90	50	10	60	80	10	25	35	45	10,5
		in	3.15	3.54	1.97	0.39	2.36	3.15	0.39	0.98	1.38	1.77	0.41
	G 3/4	mm	80	90	50	10	60	80	10	25	35	45	10,5
		in	3.15	3.54	1.97	0.39	2.36	3.15	0.39	0.98	1.38	1.77	0.41
	G 1	mm	85	100	60	10	65	90	10	23,5	40	45	10,5
		in	3.35	3.94	2.36	0.39	2.56	3.54	0.39	0.92	1.57	1.77	0.41
	SAE12	mm	80	90	50	10	60	80	10	25	35	45	10,5
		in	3.15	3.54	1.97	0.39	2.36	3.15	0.39	0.98	1.38	1.77	0.41
	SAE16	mm	80	100	50	10	60	90	10	25	35	45	10,5
		in	3.15	3.94	1.97	0.39	2.36	3.54	0.39	0.98	1.38	1.77	0.41

Order code \_\_\_\_\_

**3/CC /- □ □ /20/□- □-1**

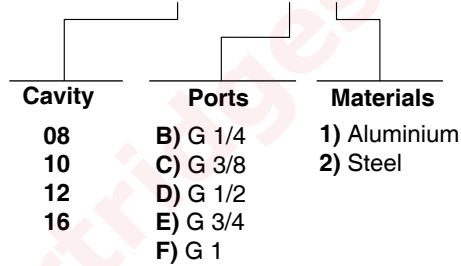



Material	Max. pressure	
	bar	psi
Alluminium	210	3050
Steel	350	5100

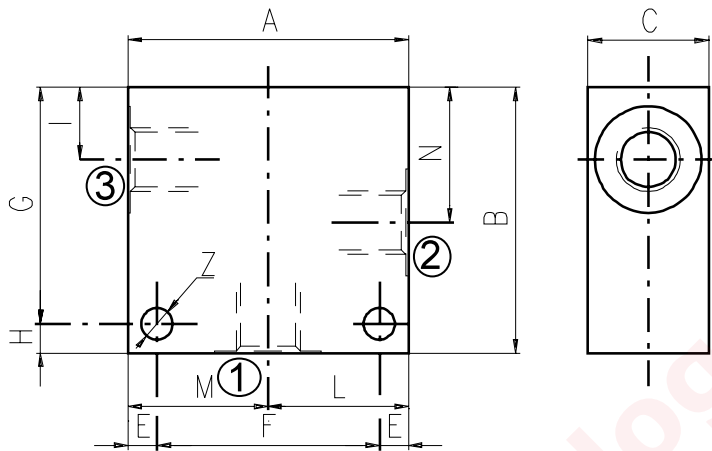

Cavity	Ports		A	B	C	E	F	G	H	I	L	M	N	Z
SAE 8/3	G 1/4	mm	60	60	30	7	46	48	12	14,8	30	30	29,1	6,5
		in	2.36	2.36	1.18	0.27	1.81	1.89	0.47	0.58	1.18	1.18	1.14	0.25
	G 3/8	mm	60	60	30	7	46	48	12	14,5	30	30	29,1	6,5
		in	2.36	2.36	1.18	0.27	1.81	1.89	0.47	0.57	1.18	1.18	1.14	0.25
	G 1/2	mm	70	65	35	7	56	53	12	14,5	35	35	29,1	6,5
		in	2.75	2.56	1.38	0.27	2.20	2.09	0.47	0.57	1.38	1.38	1.14	0.25
SAE6	mm	60	60	30	7	46	48	12	14,5	30	30	29,1	6,5	
	in	2.36	2.36	1.18	0.27	1.81	1.89	0.47	0.57	1.18	1.18	1.14	0.25	
SAE 10/3	G 1/4	mm	60	65	35	6	48	59	6	18	30	30	34,5	7
		in	2.36	2.56	1.38	0.24	1.89	2.32	0.24	0.70	1.18	1.18	1.36	0.27
	G 3/8	mm	60	65	35	6	48	59	6	18,8	30	30	34,5	7
		in	2.36	2.56	1.38	0.24	1.89	2.32	0.24	0.74	1.18	1.18	1.36	0.27
	G 1/2	mm	65	70	35	6	53	64	6	18,8	32,5	32,5	34,5	7
		in	2.56	2.75	1.38	0.24	2.09	2.52	0.24	0.74	1.28	1.28	1.36	0.27
SAE6	mm	65	70	35	6	53	64	6	18,8	32,5	32,5	34,5	7	
	in	2.56	2.75	1.38	0.24	2.09	2.52	0.24	0.74	1.28	1.28	1.36	0.27	
SAE8	mm	65	70	35	6	53	64	6	18,8	32,5	32,5	34,5	7	
	in	2.56	2.75	1.38	0.24	2.09	2.52	0.24	0.74	1.28	1.28	1.36	0.27	
SAE 12/3	G 1/2	mm	70	100	40	8	54	92	8	25	35	35	53,5	8,5
		in	2.75	3.94	1.57	0.31	2.12	3.6	0.31	0.98	1.38	1.38	2.10	0.33
	G 3/4	mm	90	100	50	10	70	90	10	25,1	45	45	53,5	10,5
		in	3.54	3.94	1.97	0.39	2.75	3.54	0.39	0.99	1.77	1.77	2.11	0.41
	SAE10	mm	80	100	40	8	64	92	8	25	40	40	53,5	8,5
		in	3.15	3.94	1.57	0.31	2.52	3.6	0.31	0.98	1.57	1.57	2.11	0.33
SAE12	mm	80	100	45	8	64	92	8	25	40	40	53,5	8,5	
	in	3.15	3.94	1.77	0.31	2.52	3.6	0.31	0.98	1.57	1.57	2.11	0.33	

Cavity	Ports	A	B	C	E	F	G	H	I	L	M	N	Z	
SAE 16/3	G 3/4	mm	90	100	50	10	70	90	10	25,1	45	45	53,5	10,5
		in	3.54	3.94	1.97	0.39	2.75	3.54	0.39	0.99	1.77	1.77	2.11	0.41
	SAE12	mm	90	105	50	10	70	95	10	25,1	45	45	53,5	10,5
		in	3.54	4.13	1.97	0.39	2.75	3.74	0.39	0.99	1.77	1.77	2.11	0.41
	SAE16	mm	90	105	50	10	70	95	10	25,1	45	45	53,5	10,5
		in	3.54	4.13	1.97	0.39	2.75	3.74	0.39	0.99	1.77	1.77	2.11	0.41

Order code \_\_\_\_\_

3/CC /- □ □ /30/□- □-1

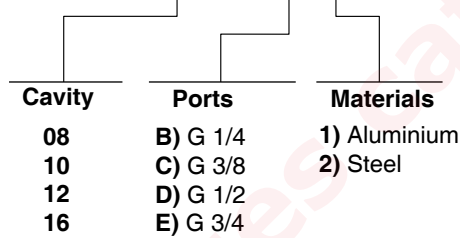

Material	Max. pressure	
	bar	psi
Alluminium	210	3050
Steel	350	5100

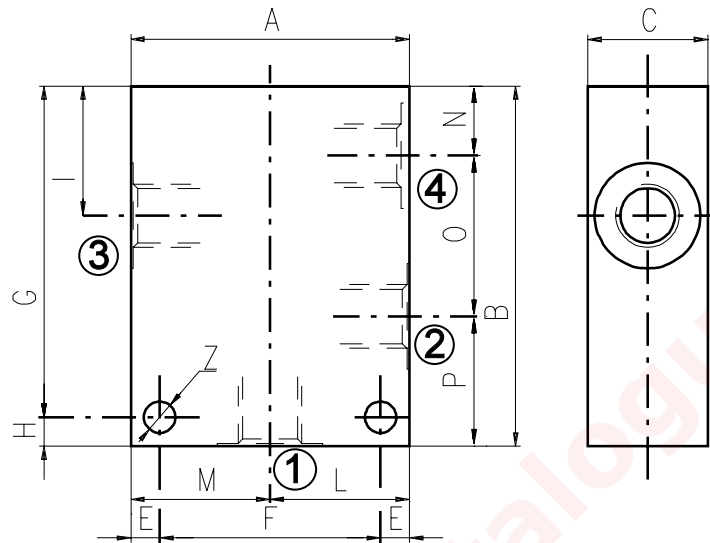

Cavity	Ports		A	B	C	E	F	G	H	I	L	M	N	O	P	Z
SAE 8/4	G 1/4	mm	60	75	30	7	46	63	12	29,1	30	30	14,8	29,1	31,1	6,5
		in	2.36	2.95	1.18	0.27	1.81	2.48	0.47	1.14	1.18	1.18	0.58	1.14	1.22	0.25
	SAE6	mm	60	75	30	7	46	63	12	29,1	30	30	14,8	29,1	31,1	6,5
		in	2.36	2.95	1.18	0.27	1.81	2.48	0.47	1.14	1.18	1.18	0.58	1.14	1.22	0.25
SAE 10/4	G 3/8	mm	60	85	35	6	48	79	6	34,5	30	30	18,8	31,7	34,5	7
		in	2.36	3.35	1.38	0.24	1.89	3.11	0.24	1.36	1.18	1.18	0.74	1.25	1.36	0.27
	G 1/2	mm	70	85	35	6	58	79	6	34,5	35	35	18,8	31,7	34,5	7
		in	2.75	3.35	1.38	0.24	2.28	3.11	0.24	1.36	1.38	1.38	0.74	1.25	1.36	0.27
	SAE6	mm	60	85	35	6	48	79	6	34,5	30	30	18,8	31,7	34,5	7
		in	2.36	3.35	1.38	0.24	1.89	3.11	0.24	1.36	1.18	1.18	0.74	1.25	1.36	0.27
SAE8	mm	70	85	35	6	58	79	6	34,5	35	35	18,8	31,7	34,5	7	
	in	2.75	3.35	1.38	0.24	2.28	3.11	0.24	1.36	1.38	1.38	0.74	1.25	1.36	0.27	
SAE 12/4	G 1/2	mm	80	115	40	8	64	107	8	44	40	40	22	44,5	48,5	8,5
		in	3.15	4.53	1.57	0.31	2.52	4.21	0.31	1.73	1.57	1.57	0.87	1.75	1.9	0.33
	SAE10	mm	80	115	40	8	64	107	8	44	40	40	22	44,5	48,5	8,5
		in	3.15	4.53	1.57	0.31	2.52	4.21	0.31	1.73	1.57	1.57	0.87	1.75	1.9	0.33
SAE 16/4	G 3/4	mm	100	130	50	10	80	120	10	53,5	50	50	25,1	56,9	48	10,5
		in	3.94	5.12	1.97	0.39	3.15	4.72	0.39	2.11	1.97	1.97	0.99	2.24	1.89	0.41

Order code

3/CC /- □ □ /40/□- □-1

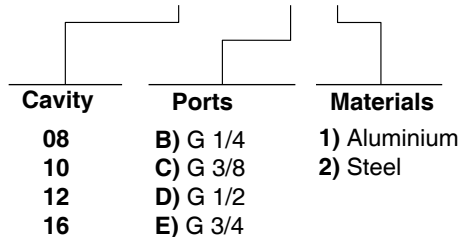

# Informations

## How to order valves with body

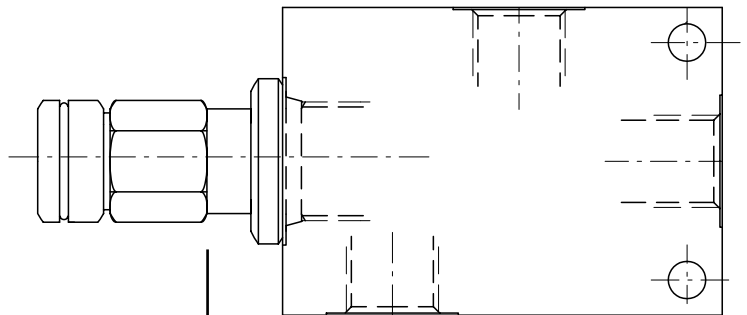

**CARTRIDGE CODE**

**BILLET CODE**

**CC-12-A/9-S-2B/**

**D- 1-1**

Cavity	Ports	Materials
08	B) G 1/4	1) Aluminium
10	C) G 3/8	
12	D) G 1/2	
16	E) G 3/4	
	F) G 1	
	J) SAE 6	2) Steel
	K) SAE 8	
	L) SAE 10	
	M) SAE 12	
	N) SAE 16	

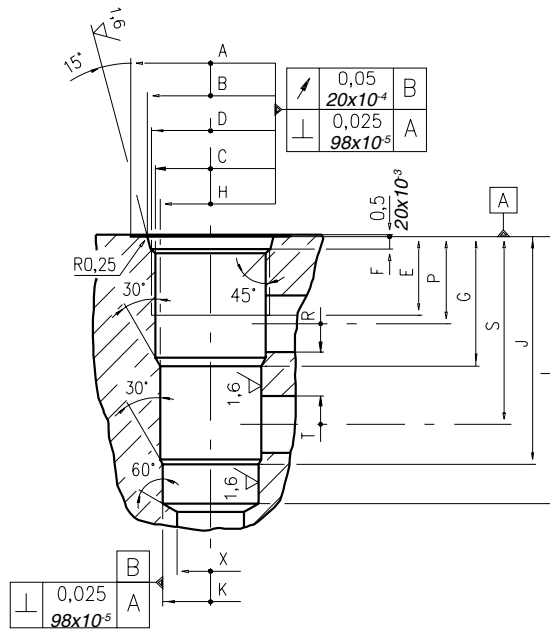

\	A	B ±0,05	C ±0,05	D	E	F	G	H ±0,02	J	K ±0,02	L	M ±0,02	N	P	R øMAX	S	T øMAX	U	V øMAX	X øMAX	Z øMIN	Prof. Z MIN	
08/3	mm	27	20,66	17,42	3/4-16 UNF	12,50	2,5	19,10	15,90	33,30	14,30	43,30	-	-	14,30	5,50	28,60	5,50	-	-	12,50	-	-
	in	1.06	0.81	0.68		0.49	0.10	0.75	0.62	1.31	0.56	1.70			0.56	0.22	1.12	0.22			0.49		
10/3	mm	30	24,00	20,62	7/8-14 UNF	16,00	2,80	23,10	17,50	39,60	15,90	47,60	-	-	18,30	6,50	34,00	6,50	-	-	14,00	-	-
	in	1.18	0.94	0.81		0.63	0.11	0.94	0.69	1.56	0.62	1.87			0.72	0.25	1.34	0.25			0.55		
12/3	mm	38	29,23	24,73	1 1/16-12 UNF	19,00	3,56	36,60	23,82	63,50	22,25	75,40	-	-	24,50	16,00	53,00	16,00	-	-	19,00	-	-
	in	1.50	1.15	0.97		0.75	0.14	1.44	0.94	2.5	0.88	2.97			0.96	0.63	2.09	0.63			0.75		
16/3	mm	45	35,6	31,34	1 5/16-12 UNF	22,00	3,5	36,50	28,62	64,30	27,02	75,38	-	-	24,60	16,00	53,00	16,00	-	-	19,00	-	-
	in	1.77	1.40	1.23		0.87	0.14	1.44	1.13	2.53	1.06	2.97			0.97	0.63	2.09	0.63			0.75		

Cavity plugs

Rougher tool

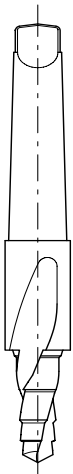

Finisher tool

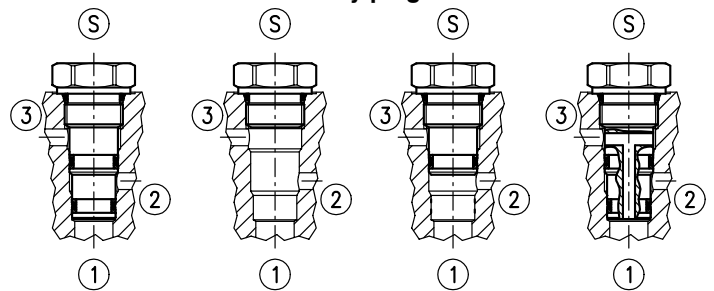

Tap

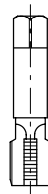

Cavity	Code number
08/3	3UT00052190
10/3	3UT00054170
12/3	3UT00054290
16/3	3UT00054470

Cavity	Code number
08/3	3UT00052740
10/3	3UT00054180
12/3	3UT00054300
16/3	3UT00054480

Cavity	Code number
08/3	3UT03416UNF
10/3	3UT07814UNF
12/3	3UT0111612UN
16/3	3UT0151612UN

## Dimensions

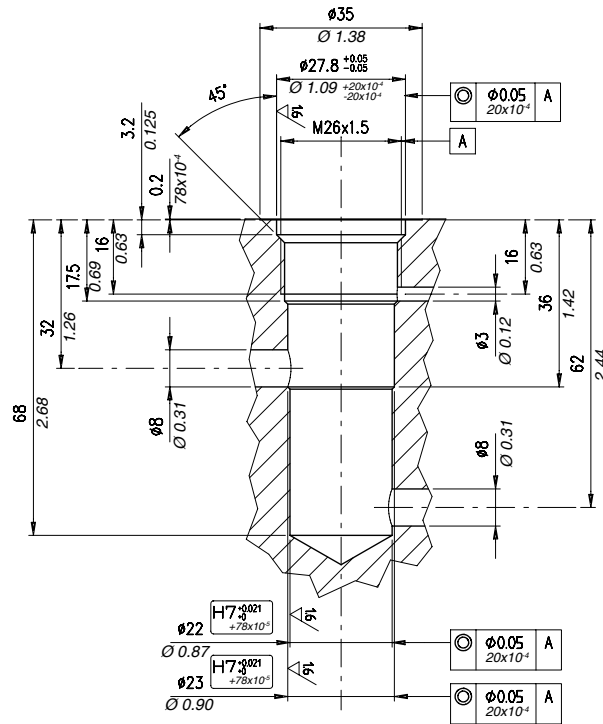

Rougher tool

Cod.3UT00052430

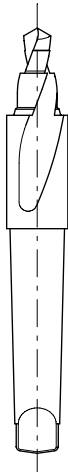

Finisher

Cod.3UT00053540



Tap

Cod.3UT08A26F150





## Dimensions

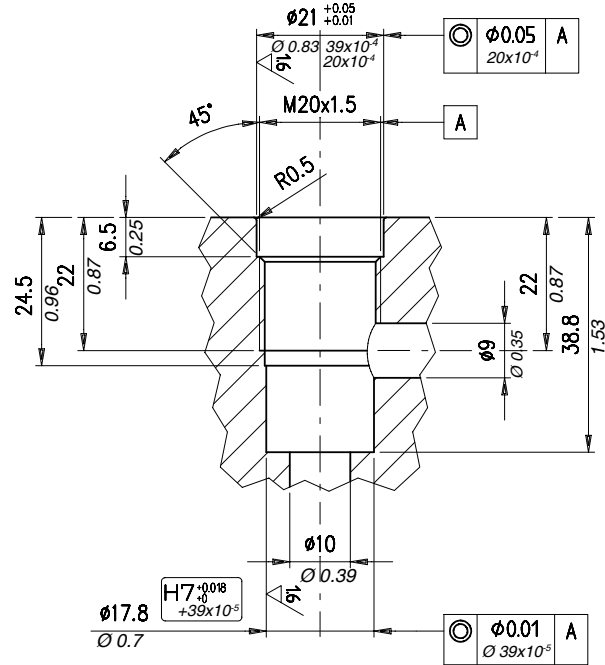

**Rougher tool**

**Cod.3UT00050050**

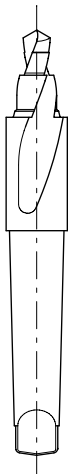

**Finisher**

**Cod.3UT00055040**



**Tap**

**Cod.3UT08A20F150**





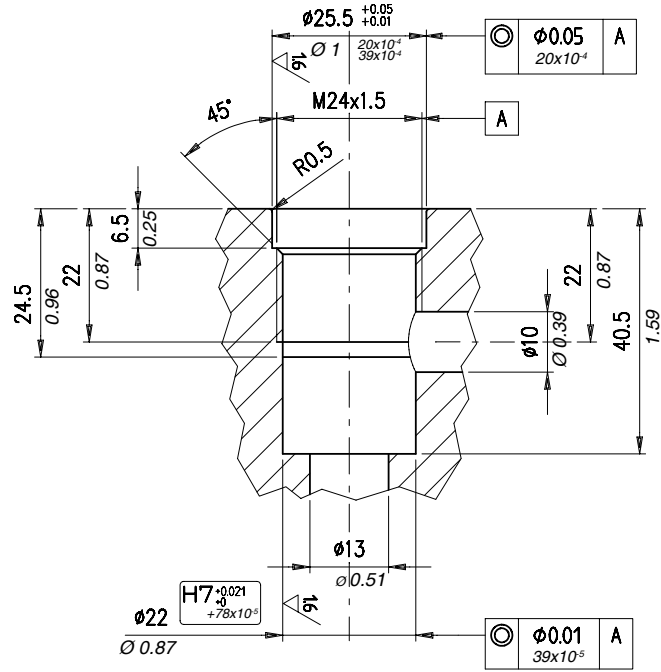

Rougher tool  
Cod.3UT00050070

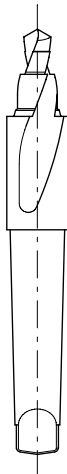

Finisher  
Cod.3UT06A22000P



Tap  
Cod.3UT08A24F150

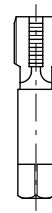

## Dimensions

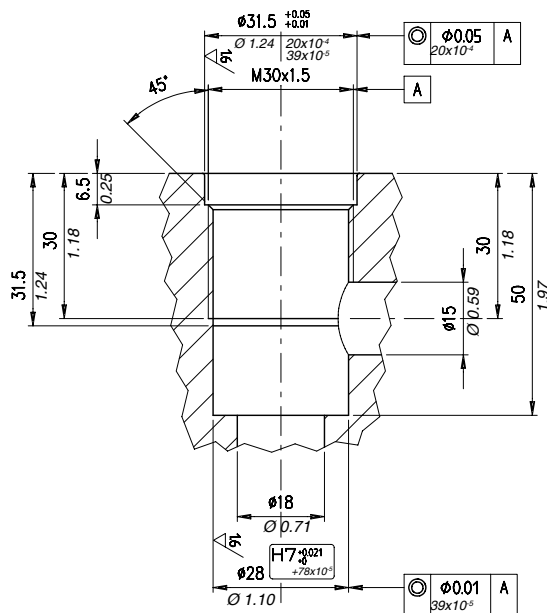

**Rougher tool**  
Cod.3UT00050100

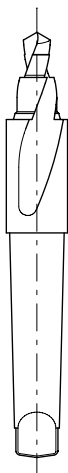

**Finisher**  
Cod.3UT06A2800P



**Tap**  
Cod.3UT08A30F150

