



# Flow control pressure compensated valves

**Index**

Hydraulic diagram	Type	Description	Maximum flow up to		Maximum pressure		Page
			l/min	US gpm	bar	psi	
	<b>VPR/3/EP..VMP+VE</b>	3-ways flow regulator, exceeding flow to pressure, pressure relief valve and electrical cut-off on the checked way	450	119	350	5100	93

**Operation**

The valve is designed to provide flow adjustment in C and concurrently discharge exceeding flow in R for other applications. A pressure relief valve provides control of the working pressure in C, while the solenoid allows for checked flow cut-off in C and retrieving in R. Best performance of the valve is assured when the flow in E is at least 10% bigger than in C and a minimum pressure of 7-10 bar (100-145 psi) is available in C or R. Pressure variations in C do not alter the checked flow. Working pressure in R can not exceed the rating value of the pressure relief valve in C, or else the whole E flow would end into R. When cutting-off in C, a crossing load loss of 7 bar (100 psi) and a constant few liters drain occur in D due to the working pressure in R. Make sure that a pressure relief valve is always used between the pump and the valve. The steel body version is recommended for use to control hydraulic hammers.

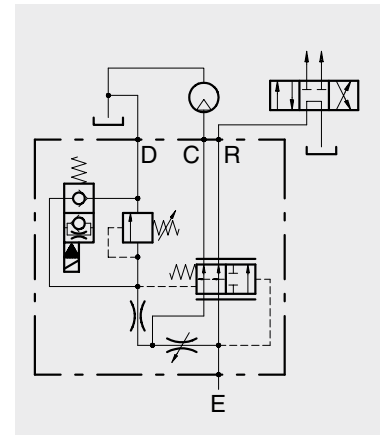

**Performance**

**Body Valves**

Type VPR/3/EP	Flow		Max. pressure	Coils	Weight kg lb	Relief cartridge valve
	l/min.	US gpm				
VPR/3/EP 38/VMP+VE	E=50 C=30	E=13 C=8	210 bar -3050 psi- (aluminium body) 350 bar -5100 psi- (steel body)	BE/ ... (210 bar -3050 psi-) see page 118 BT/ ... (350 bar -5100 psi-) see page 119	2,10 (alum.) 4,05 (steel)	VMP02 electricvalve (210 bar -3050 psi-) EC08A electricvalve (350 bar -5100 psi-) EC08B on request
VPR/3/EP 12/VMP+VE	E=90 C=50	E=24 C=13			4,63 (alum.) 8,05 (steel)	
VPR/3/EP/34/VMP+VE	E=150 C=90	E=40 C=24			3,63 (alum.) 7,00 (steel) 8 (alum.) 15,43 (steel)	
VPR/3/EP/100/VMP+VE	E=240 C=150	E=63 C=40			5,60 (alum.) 11,15 (steel) 12,34 (alum.) 24,58 (steel)	
VPR/3/EP/114/VMP+VE	E=450 C=250	E=119 C=66			8,15 (alum.) 18 (steel) 17,97 (alum.) 39,68 (steel)	

# Type VPR/3/EP 38 (12)/VMP+VE

3 ways flow regulator, pressure compensated, exceeding flow to pressure. Pressure relief valve and electrical cut-off on the checked way

## Dimensions and hydraulic circuit

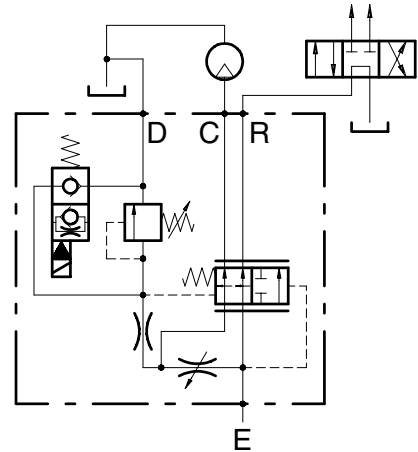
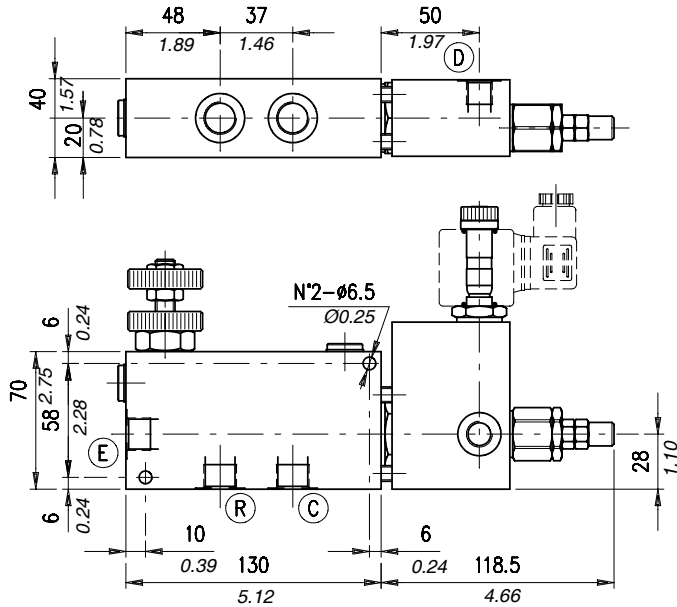

VPR/3/EP ... VMP+VE	E	R	C	D
38	G 3/8	G 3/8	G 3/8	G 1/4
12	G 1/2	G 1/2	G 1/2	G 1/4

## Rating diagrams

Pressure compensation diagram (38)

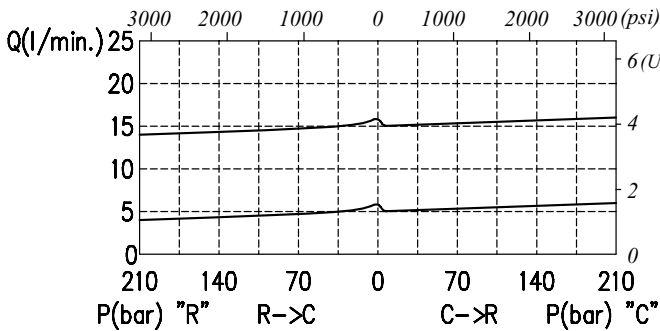

Pressure compensation diagram (12)

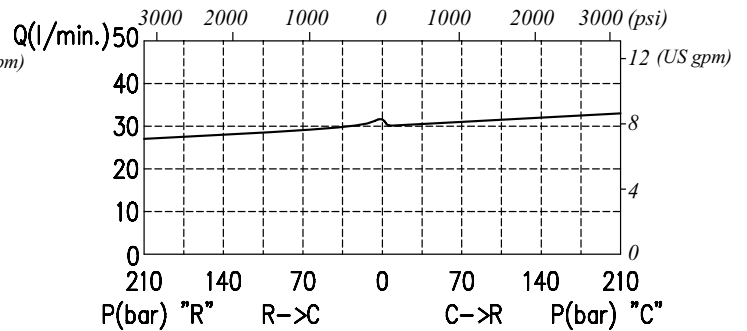

## Order code

VPR /3 /EP □ /VMP + VE . □ / □ /03 . □ / □

Port size	Assembly scheme	Adjustments (see page 122)	Pressure Settings (bar)	Body material
38 G 3/8 12 G 1/2	NA) Normally opened NC) Normally closed	S (screw) V (handknob) L (lever) MG (handknob calib. m.a) MGB (handknob calibrated f.a)	TB 0÷50 (0÷725 psi) TS 50÷220 (725÷3200 psi) TR 180÷400 (2600÷5800 psi)	Aluminium ac Steel



3 ways flow regulator, pressure compensated, exceeding flow to pressure.  
Pressure relief valve and electrical cut-off on the checked way

# Type VPR/3/EP 34/VMP+VE

## Dimensions and hydraulic circuit

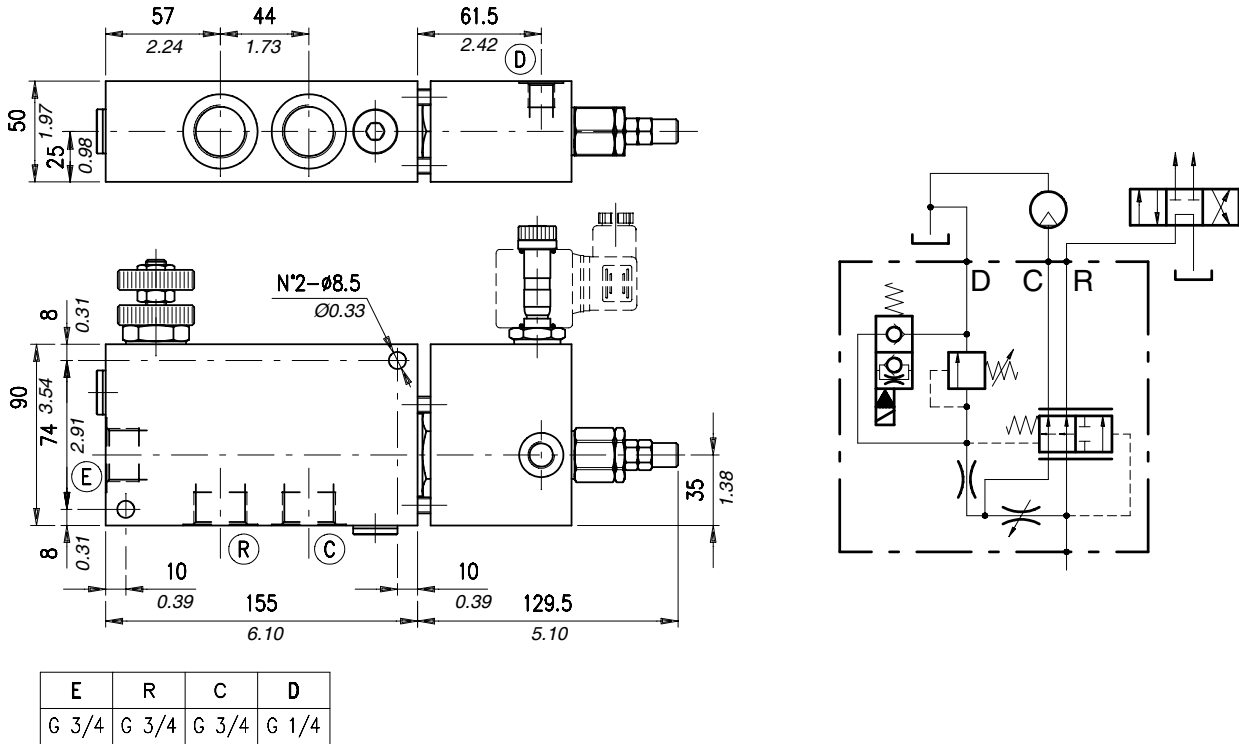

## Rating diagrams

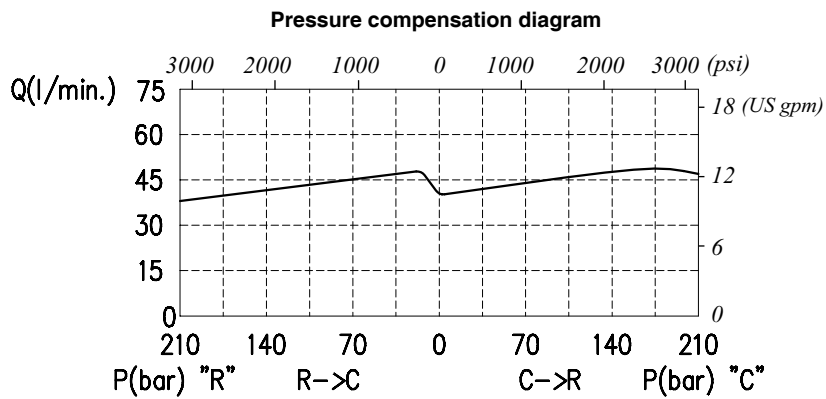

## Order code

VPR /3 /EP 34 /VMP + VE . □ / □ /03 . □ / □

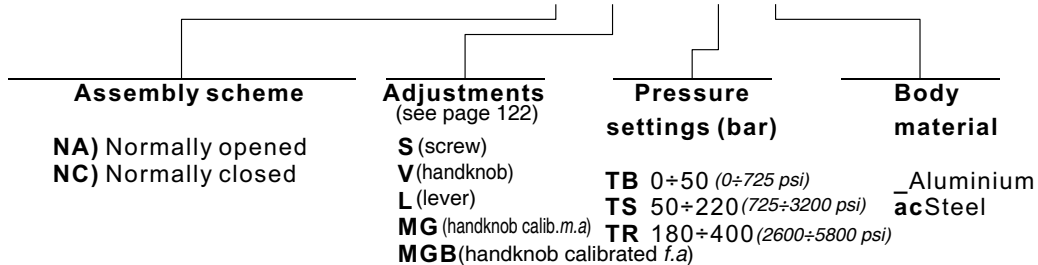

# Type VPR/3/EP 100/VMP+VE

3 ways flow regulator, pressure compensated, exceeding flow to pressure.  
Pressure relief valve and electrical cut-off on the checked way

## Dimensions and hydraulic circuit

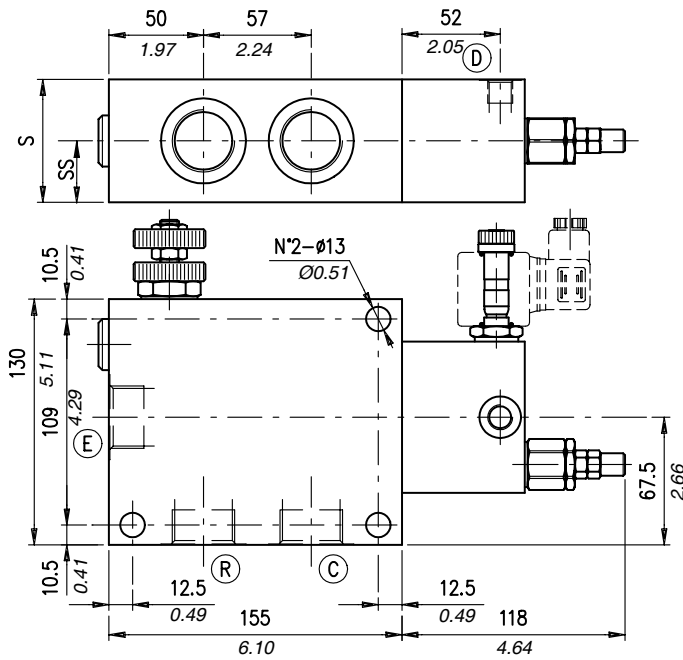

E	R	C	D
G 1	G 1	G 1	G 1/4

S	SS	Material
70 - 2.75	35 - 1.38	Aluminium
65 - 2.60	32.5 - 1.28	Steel

Dimensions are in mm - in

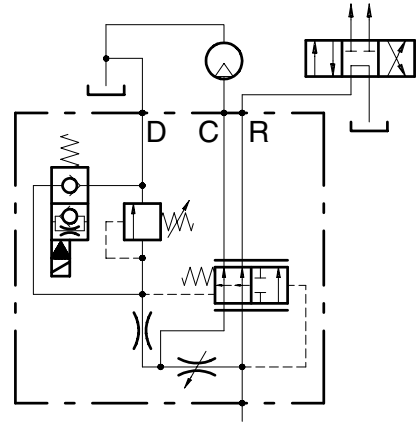

## Rating diagrams

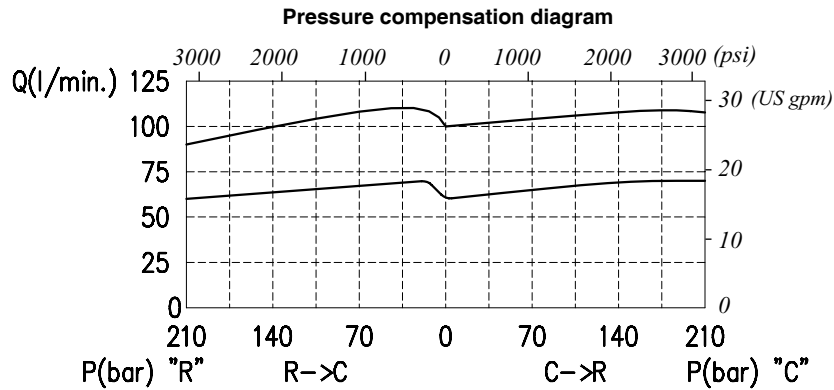

## Order code

VPR / 3 / EP 100 / VMP + VE . □ / □ / 03 . □ / □

Assembly scheme	Adjustments (see page 122)	Pressure settings (bar)	Body material
<p>NA) Normally opened NC) Normally closed</p>	<p>S (screw) V (handknob) L (lever) MG (handknob calib. m.a) MGB (handknob calibrated f.a)</p>	<p>TB 0÷50 (0÷725 psi) TS 50÷220 (725÷3200 psi) TR 180÷400 (2600÷5800 psi)</p>	<p>_ Aluminium ac Steel</p>

3 ways flow regulator, pressure compensated, exceeding flow to pressure.  
 Pressure relief valve and electrical cut-off on the checked way

# Type VPR/3/EP 114/VMP+VE

## Dimensions and hydraulic circuit

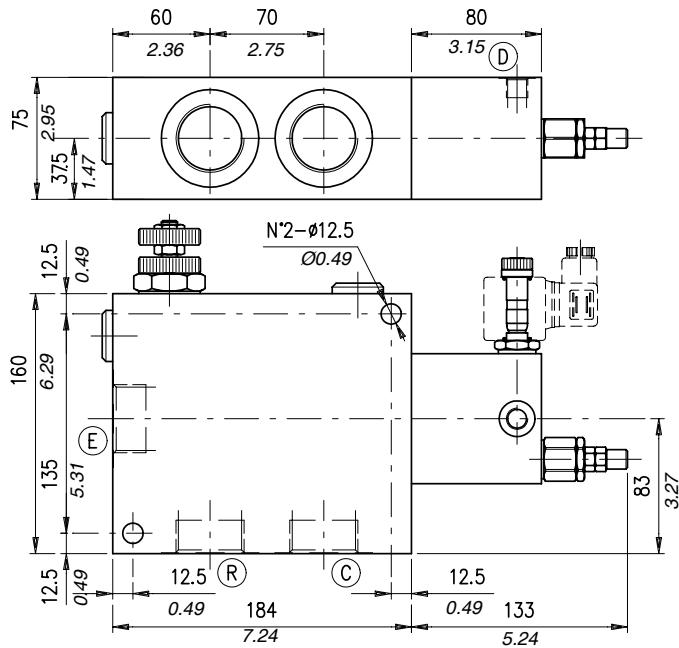

E	R	C	D
G 1 1/4	G 1 1/4	G 1 1/4	G 1/4

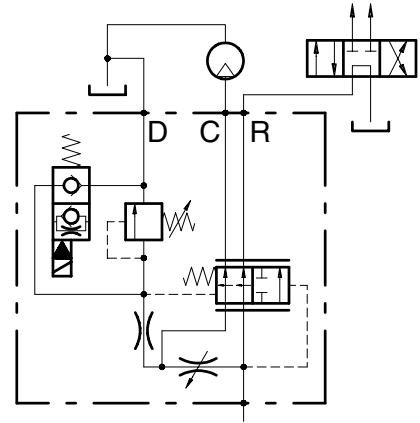

## Rating diagrams

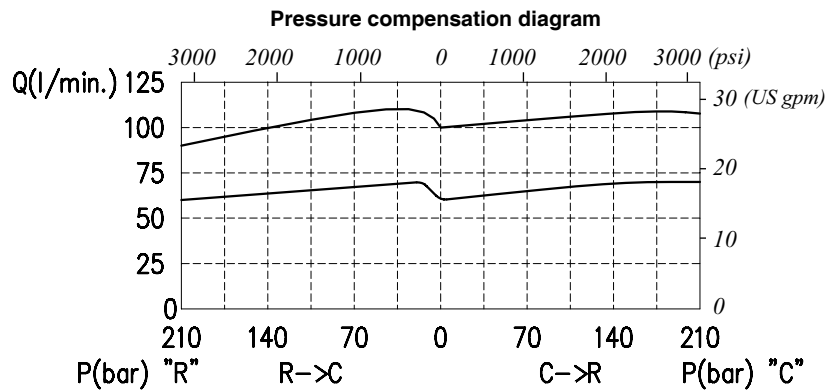

## Order code

VPR /3 /EP 114 /VMP + VE . □ / □ /03 . □ / □

<p><b>Assembly scheme</b></p> <p><b>NA</b>) Normally opened  <b>NC</b>) Normally closed</p>	<p><b>Adjustments</b>                  (see page 122)</p> <p><b>S</b> (screw)  <b>V</b> (handknob)  <b>L</b> (lever)  <b>MG</b> (handknob calib. <i>m.a</i>)  <b>MGB</b> (handknob calibrated <i>f.a</i>)</p>	<p><b>Pressure settings (bar)</b></p> <p><b>TB</b> 0÷50 (<i>0÷725 psi</i>)  <b>TS</b> 50÷220 (<i>725÷3200 psi</i>)  <b>TR</b> 180÷400 (<i>2600÷5800 psi</i>)</p>	<p><b>Body material</b></p> <p>— Aluminium                  — acSteel</p>
---	---	--	---

## ELECTRIC COILS FOR TUBE

## Operation

Multiple coil versions are available to allow use with direct and alternated current.

**Thermal insulation class:** F ( $T_{max} = 155^{\circ}\text{C}-303^{\circ}\text{F}$ ) - (VDE 0580)

**Relative duty cycle:** ED 100% (VDE 0580)

To assure ED = 100% and perform continuous coil operation, the following conditions should be met:

$TA + \Delta T < T_{max}$

Whereas:

- $TA$  = ambient temperature

- $\Delta T$  = temperature increase due to operation

- $T_{max}$  = maximum admissible temperature according to insulation class

We therefore recommend always checking that the maximum ambient temperature is same as  $T_{max} - \Delta T$  (providing no special operating requirement are there).

**Safety standards (DIN 40050):** IP54 without connector

IP65 with connector

**Admissible voltage range for long lasting and trouble free operations life:** nominal voltage  $\pm 10\%$

## Performance

Type	Resistance $\Omega$  $T_A=20^{\circ}\text{C}$ $68^{\circ}\text{F}$	Current (A)		Power (W) or (VA)  Cold	$\Delta T$	
		Cold	Warm		After 1 hour at: - $T_a=20-25^{\circ}\text{C}$ $68-77^{\circ}\text{F}$ -Nominal voltage	
					( $^{\circ}\text{C}$ )	( $^{\circ}\text{F}$ )
BE 12 Vcc	7,7	1,56	1,16	18,7 W	110	230
BE 24 Vcc	31	0,77	0,58	18,6 W	110	230
BE 48 Vcc	116	0,41	0,3	19,8 W	115	238
BE 110 Vcc	700	0,157	0,12	17,3 W	105	221
BE 24 Vca (50 Hz)	5,3	1,16	0,87	28 VA	105	221
BE 48 Vca (50 Hz)	21,3	0,6	0,45	28,8 VA	105	221
BE 110 Vca (50 Hz)	108	0,26	0,19	28,6 VA	105	221
BE 220 Vca (50 Hz)	438	0,13	0,09	28,6 VA	105	221
BE 380 Vca (50 Hz)	1400	0,09	0,06	34,2 VA	105	221
BE 24 RAC	27	0,8	0,6	17,3 W	105	221
BE 110 RAC	630	0,157	0,12	15,6 W	100	212
BE 220 RAC	2500	0,08	0,06	15,7 W	100	212
BT 12 Vcc	6,8	1,77	1,15	21 W	-	-
BT 24 Vcc	27	0,89	0,58	21 W	-	-
BT 48 Vcc	110	0,43	0,32	20,3 W	105	221
BT 110 Vcc	700	0,15	0,11	15,7 W	100	212
BT 24 Vca (50 Hz)	4,2	0,94	0,83	22,6 VA	-	-
BT 48 Vca (50 Hz)	15,3	0,73	0,54	35 VA	105	221
BT 110 Vca (50 Hz)	89	0,21	0,18	23,1 VA	-	-
BT 220 Vca (50 Hz)	350	0,1	0,08	22 VA	-	-
BT 24 RAC	90	0,47	0,37	20,7 W	105	221
BT 110 RAC	540	0,2	0,16	21,6 W	110	230
BT 220 RAC	2170	0,1	0,08	21,7 W	105	221

## Dimensions

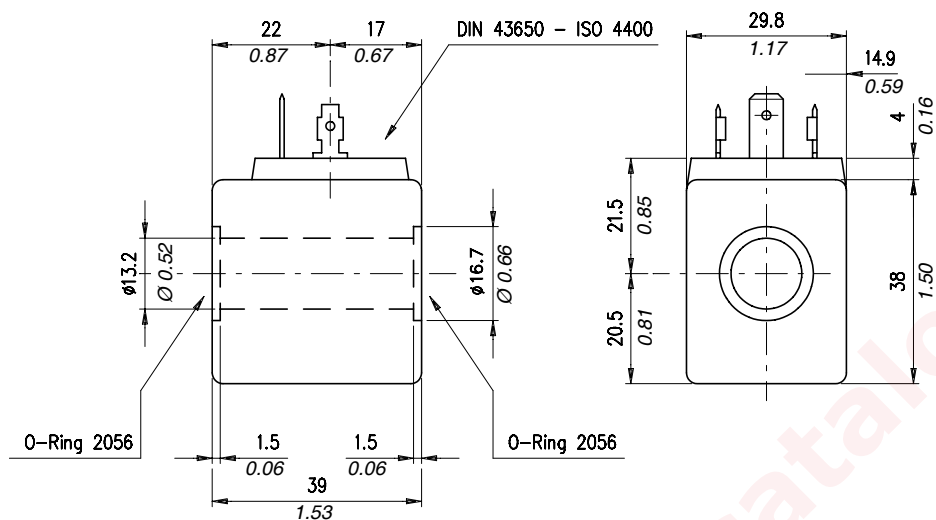

## Order code

Type	Ordering code	Ordering code with standard connector	Standard connector code	Connector page
BE 12 Vcc	4SL1000120	5SL1000120	4CN1009990	Page 121 (CC-CA)
BE 24 Vcc	4SL1000240	5SL1000240		
BE 48 Vcc	4SL1000480	5SL1000480		
BE 110 Vcc	4SL1001100	5SL1001100		
BE 24 Vca (50 Hz)	4SL1010240	5SL1010240		
BE 48 Vca (50 Hz)	4SL1010480	5SL1010480		
BE 110 Vca (50 Hz)	4SL1011100	5SL1011100		
BE 220 Vca (50 Hz)	4SL1012200	5SL1012200		
BE 380 Vca (50 Hz)	4SL1013800	5SL1013800	4CN1010240	Page 121 (CL)
BE 24 RAC	4SL1030240	5SL1030240		
BE 110 RAC	4SL1031100	5SL1031100		
BE 220 RAC	4SL1032200	5SL1032200	4CN1012200	

Dimensions and assembly diagram

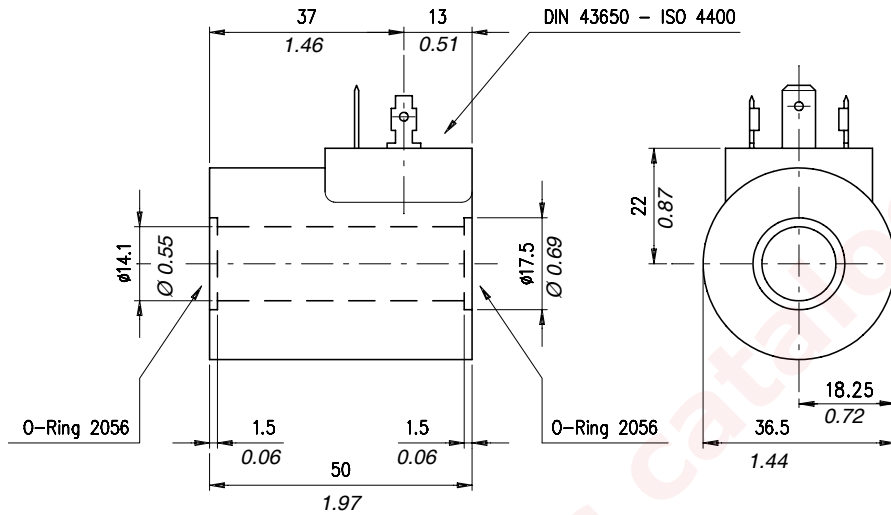

Order code

Type	Ordering code	Ordering code with standard connector	Standard connector code	Connector page
BT 12 Vcc	4SL3000120	5SL3000120	4CN1009990	Page 121 (CC-CA)
BT 24 Vcc	4SL3000240	5SL3000240		
BT 48 Vcc	4SL3000480	5SL3000480		
BT 110 Vcc	4SL3001100	5SL3001100		
BT 24 Vca (50 Hz)	4SL3010240	5SL3010240		
BT 48 Vca (50 Hz)	4SL3010480	5SL3010480		
BT 110 Vca (50 Hz)	4SL3011100	5SL3011100		
BT 220 Vca (50 Hz)	4SL3012200	5SL3012200	4CN3010240	Page 121 (CP)
BT 24 RAC	4SL3030240	5SL3030240		
BT 48 RAC	4SL3030480	5SL3030480		
BT 110 RAC	4SL3031100	5SL3031100		
BT 220 RAC	4SL3032200	5SL3032200	4CN3012200	

## Operation

Proportional coil. 12 and 24 coils direct voltage, supply a force proportional to the current amount.

**thermal insulation class:** F (TMAX = 155 °C-303°F-) - (VDE 0580).

**Relative duty cycle:** ED = 100 % (VDE 0580).

To assure ED=100% and perform continuous coil operation, the following conditions should be met:

$T_A + \Delta T < T_{MAX}$

$T_A$  = ambient temperature;  $\Delta T$  = a temperature increase due to operation;  $T_{MAX}$  = maximum admissible temperature according to insulation class.

We therefore recommend always checking that the maximum ambient temperature is same as  $T_{max} - \Delta T$  (providing no special operating requirement are there).

**Safety standards (DIN40050):** IP 54 without connector

IP 65 with connector

**Admissible voltage range for long lasting and trouble free operations life:** nominal voltage  $\pm 10\%$

**Current Hysteresis:** <2,5%

**Force Hysteresis:** <2%

Voltage [Volt]	Resistance [ $\Omega$ ] Ta=20°C 68°F	Current [A]		Power [W]		$\Delta T$ [C°] After 1 hour at: Ta=20-25°C 68-77°F -Nominal voltage	Weight	
		cold	warm	nom.	lim.		kg	lb
(35x35) 12	7,2	1,25		11,2	17,4	120	0,43	0,95
(35x35) 24	24,6	0,68		11,4				
(45x45) 12	4,3	1,78		13,6	20,8		0,75	1,65
(45x45) 24	21	0,81		13,8				

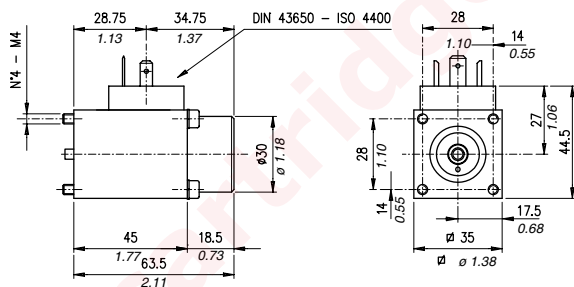

**P.C. 35X35**

Type	Ordering code	Ordering code with standard connector	Standard connector code	Connector page
35x35 12 Vcc	4SL4000120	5SL4000120	4CN1009990	see page 121 (CC-CA)
35x35 24 Vcc	4SL4000240	5SL4000240		

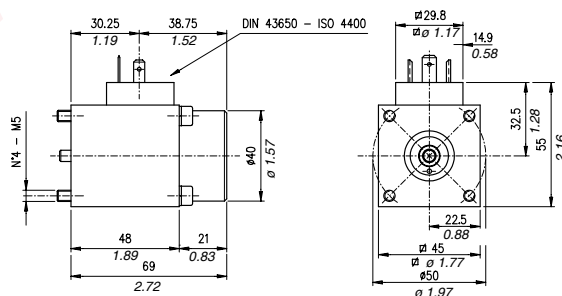

**P.C. 45X45**

Type	Ordering code	Ordering code with standard connector	Standard connector code	Connector page
45x45 12 Vcc	4SL4000243	5SL4000243	4CN1009990	see page 121 (CC-CA)
45x45 24 Vcc	4SL4000241	5SL4000241		

**Operation**

There are 3 types of different solenoid connectors:

**"CC-CA"** 2-poles + GROUND electric connectors in compliance with DIN and A/ISO standards 43650 and 4400.

Electric connectors suitable for connection of DC and AC current coils. Type of current must be same as for the coil used.

**"CL"** 2-poles + rectifier + GROUND electric connectors in compliance with DIN and A/ISO standards 43650 and 4400.

Electric connectors suitable for connection of DC current coils BE...RAC. AC current operation only. Use of these poles depends on the type of valve used.

**"CP"** 2-poles + rectifier + GROUND electric connectors in compliance with DIN and A/ISO standards 43650 and 4400.

Electric connectors suitable for connection of DC current coils BT...RAC. AC current operation only. Use of these poles depends on the type of valve used.

Type	Nominal voltage	Maximum capacity of in-built diode	Nominal poles voltage	Max poles voltage	Poles resistance	Max poles section	Cable size options	Cable diameter	Safety standards	Insulation index
CC-CA	AC	-	10 A	16 A	≤ 4 m Ohm	1,5 mm <sup>2</sup> 0.002in <sup>2</sup>	Pg09	6-8 mm 0.24-0.31 in	IP65 (DIN 40050)	VDE0110-1/89
CL	max 250 V DC	1 A								
CP	max 300 V	3 A								

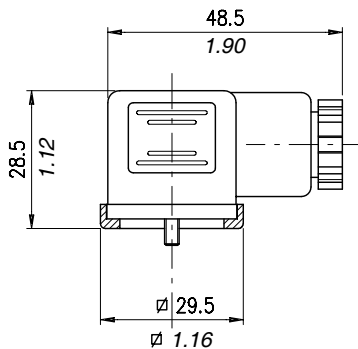

**Order code: CC-CA Connector**

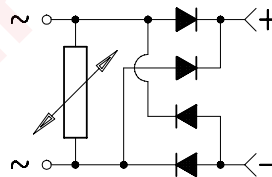
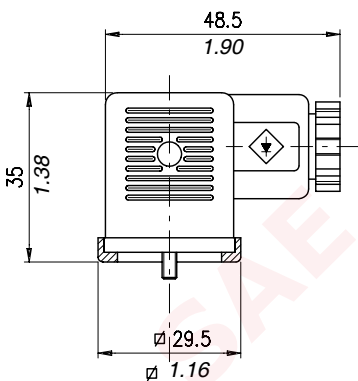

**Order code: CL Connector**

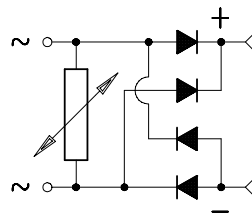
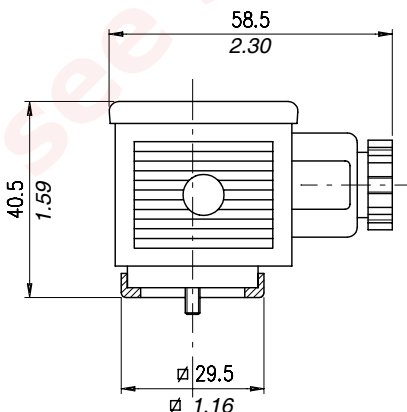

**Order code: CP Connector**



# Adjustments

## Description and operation

This chapter show main adjusting devices for the valves listed in this catalog.  
These regulations are used to adjust flow rate between inlet and working ports.

## Performance

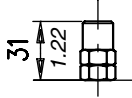
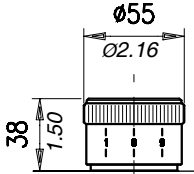
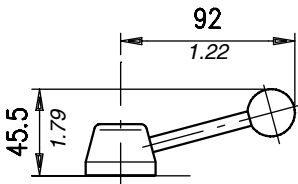
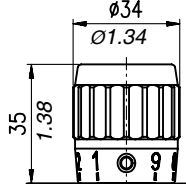
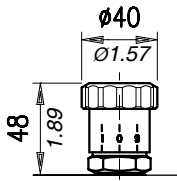
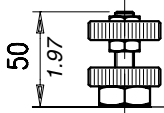
	<p><b>Screw "S"</b></p>		<p><b>Handknob calibrated "MGB" (fine adjusting)</b></p>
	<p><b>Lever "L" (rotation=180°)</b></p>		<p><b>Handknob calibrated "M"</b></p>
	<p><b>Handknob calibrated "MG" (medium adjusting)</b></p>		<p><b>Handknob "V"</b></p>

Material	Max. pressure	
	bar	psi
Aluminium	210	3050
Steel	350	5100

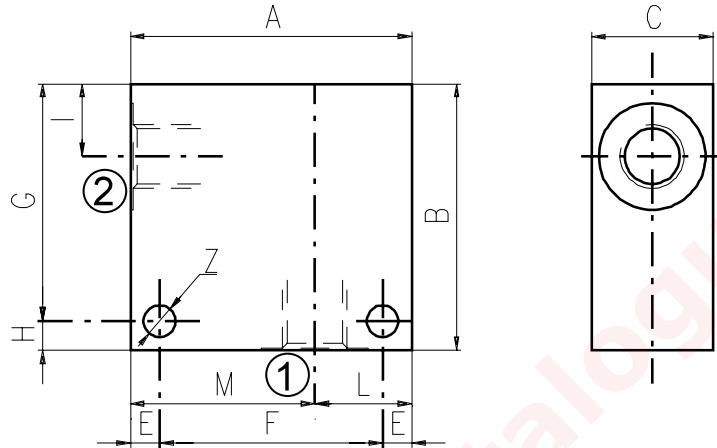

Cavità	Attacchi		A	B	C	E	F	G	H	I	L	M	Z
SAE 8/2	G 1/2	mm	70	65	35	7	56	53	12	14,5	35	35	6,5
		in	2.75	2.56	1.38	0.27	2.20	2.09	0.47	0.57	1.38	1.38	0.25
	G 1/4	mm	50	50	30	6	38	44	6	14,8	20	30	6,5
		in	1.97	1.97	1.18	0.24	1.50	1.73	0.24	0.58	0.79	1.18	0.25
	G 3/8	mm	50	50	30	6	38	44	6	14,8	20	30	6,5
		in	1.97	1.97	1.18	0.24	1.50	1.73	0.24	0.58	0.79	1.18	0.25
SAE6	mm	50	50	30	6	38	44	6	14,8	20	30	6,5	
	in	1.97	1.97	1.18	0.24	1.50	1.73	0.24	0.58	0.79	1.18	0.25	
SAE 10/2	G 1/4	mm	60	60	35	6	48	54	6	18,8	25	35	6,5
		in	2.36	2.36	1.38	0.24	1.89	2.12	0.24	0.74	0.98	1.38	0.25
	G 3/8	mm	60	60	35	6	48	54	6	18,8	25	35	6,5
		in	2.36	2.36	1.38	0.24	1.89	2.12	0.24	0.74	0.98	1.38	0.25
	G 1/2	mm	60	60	35	6	48	54	6	18,8	25	35	6,5
		in	2.36	2.36	1.38	0.24	1.89	2.12	0.24	0.74	0.98	1.38	0.25
	SAE8	mm	60	70	35	6	48	64	6	18,8	25	35	6,5
		in	2.36	2.75	1.38	0.24	1.89	2.52	0.24	0.74	0.98	1.38	0.25
	SAE10	mm	70	70	35	6	58	64	6	18,5	35	35	6,5
		in	2.75	2.75	1.38	0.24	2.28	2.52	0.24	0.73	1.38	1.38	0.25
SAE12	mm	70	70	40	8	54	62	8	22	30	40	8,5	
	in	2.75	2.75	1.57	0.31	2.12	2.44	0.31	0.87	1.18	1.57	0.33	
SAE 12/2	G 1/2	mm	70	80	40	8	54	72	8	25	30	40	8,5
		in	2.75	3.15	1.57	0.31	2.12	2.83	0.31	0.98	1.18	1.57	0.33
	G 3/4	mm	70	90	40	8	54	82	8	25	30	40	8,5
		in	2.75	3.54	1.57	0.31	2.12	3.23	0.31	0.98	1.18	1.57	0.33
	SAE10	mm	70	85	40	8	54	77	8	25	30	40	8,5
		in	2.75	3.35	1.57	0.31	2.12	3.03	0.31	0.98	1.18	1.57	0.33
	SAE12	mm	70	85	40	8	54	77	8	25	30	40	8,5
		in	2.75	3.35	1.57	0.31	2.12	3.03	0.31	0.98	1.18	1.57	0.33

Cavity	Ports	A	B	C	E	F	G	H	I	L	M	Z	
SAE 16/2	G 1/2	mm	80	90	50	10	60	80	10	25	35	45	10,5
		in	3.15	3.54	1.97	0.39	2.36	3.15	0.39	0.98	1.38	1.77	0.41
	G 3/4	mm	80	90	50	10	60	80	10	25	35	45	10,5
		in	3.15	3.54	1.97	0.39	2.36	3.15	0.39	0.98	1.38	1.77	0.41
	G 1	mm	85	100	60	10	65	90	10	23,5	40	45	10,5
		in	3.35	3.94	2.36	0.39	2.56	3.54	0.39	0.92	1.57	1.77	0.41
	SAE12	mm	80	90	50	10	60	80	10	25	35	45	10,5
		in	3.15	3.54	1.97	0.39	2.36	3.15	0.39	0.98	1.38	1.77	0.41
	SAE16	mm	80	100	50	10	60	90	10	25	35	45	10,5
		in	3.15	3.94	1.97	0.39	2.36	3.54	0.39	0.98	1.38	1.77	0.41

Order code

3/CC /- □ □ /20/□- □-1

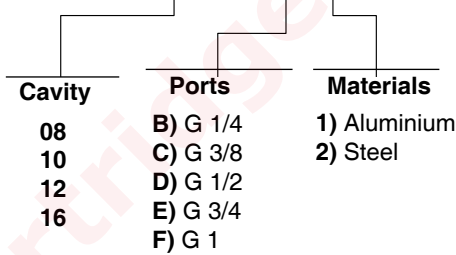

Material	Max. pressure bar	
	bar	psi
Aluminium	210	3050
Steel	350	5100

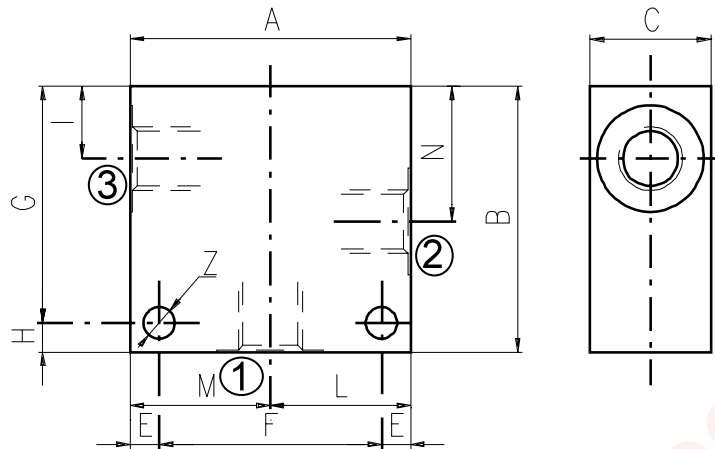

Cavity	Ports		A	B	C	E	F	G	H	I	L	M	N	Z
SAE 8/3	G 1/4	mm	60	60	30	7	46	48	12	14,8	30	30	29,1	6,5
		in	2.36	2.36	1.18	0.27	1.81	1.89	0.47	0.58	1.18	1.18	1.14	0.25
	G 3/8	mm	60	60	30	7	46	48	12	14,5	30	30	29,1	6,5
		in	2.36	2.36	1.18	0.27	1.81	1.89	0.47	0.57	1.18	1.18	1.14	0.25
	G 1/2	mm	70	65	35	7	56	53	12	14,5	35	35	29,1	6,5
		in	2.75	2.56	1.38	0.27	2.20	2.09	0.47	0.57	1.38	1.38	1.14	0.25
	SAE6	mm	60	60	30	7	46	48	12	14,5	30	30	29,1	6,5
		in	2.36	2.36	1.18	0.27	1.81	1.89	0.47	0.57	1.18	1.18	1.14	0.25
SAE 10/3	G 1/4	mm	60	65	35	6	48	59	6	18	30	30	34,5	7
		in	2.36	2.56	1.38	0.24	1.89	2.32	0.24	0.70	1.18	1.18	1.36	0.27
	G 3/8	mm	60	65	35	6	48	59	6	18,8	30	30	34,5	7
		in	2.36	2.56	1.38	0.24	1.89	2.32	0.24	0.74	1.18	1.18	1.36	0.27
	G 1/2	mm	65	70	35	6	53	64	6	18,8	32,5	32,5	34,5	7
		in	2.56	2.75	1.38	0.24	2.09	2.52	0.24	0.74	1.28	1.28	1.36	0.27
	SAE6	mm	65	70	35	6	53	64	6	18,8	32,5	32,5	34,5	7
		in	2.56	2.75	1.38	0.24	2.09	2.52	0.24	0.74	1.28	1.28	1.36	0.27
	SAE8	mm	65	70	35	6	53	64	6	18,8	32,5	32,5	34,5	7
		in	2.56	2.75	1.38	0.24	2.09	2.52	0.24	0.74	1.28	1.28	1.36	0.27
SAE 12/3	G 1/2	mm	70	100	40	8	54	92	8	25	35	35	53,5	8,5
		in	2.75	3.94	1.57	0.31	2.12	3.6	0.31	0.98	1.38	1.38	2.10	0.33
	G 3/4	mm	90	100	50	10	70	90	10	25,1	45	45	53,5	10,5
		in	3.54	3.94	1.97	0.39	2.75	3.54	0.39	0.99	1.77	1.77	2.11	0.41
	SAE10	mm	80	100	40	8	64	92	8	25	40	40	53,5	8,5
		in	3.15	3.94	1.57	0.31	2.52	3.6	0.31	0.98	1.57	1.57	2.11	0.33
	SAE12	mm	80	100	45	8	64	92	8	25	40	40	53,5	8,5
		in	3.15	3.94	1.77	0.31	2.52	3.6	0.31	0.98	1.57	1.57	2.11	0.33

Cavity	Ports	A	B	C	E	F	G	H	I	L	M	N	Z	
SAE 16/3	G 3/4	mm	90	100	50	10	70	90	10	25,1	45	45	53,5	10,5
		in	3.54	3.94	1.97	0.39	2.75	3.54	0.39	0.99	1.77	1.77	2.11	0.41
	SAE12	mm	90	105	50	10	70	95	10	25,1	45	45	53,5	10,5
		in	3.54	4.13	1.97	0.39	2.75	3.74	0.39	0.99	1.77	1.77	2.11	0.41
	SAE16	mm	90	105	50	10	70	95	10	25,1	45	45	53,5	10,5
		in	3.54	4.13	1.97	0.39	2.75	3.74	0.39	0.99	1.77	1.77	2.11	0.41

Order code \_\_\_\_\_

3/CC /- □ □ /30/□- □-1

Cavity	Ports	Materials
08	B) G 1/4	1) Aluminium
10	C) G 3/8	2) Steel
12	D) G 1/2	
16	E) G 3/4	

Material	Max pressure	
	bar	psi
Alluminium	210	3050
Steel	350	5100

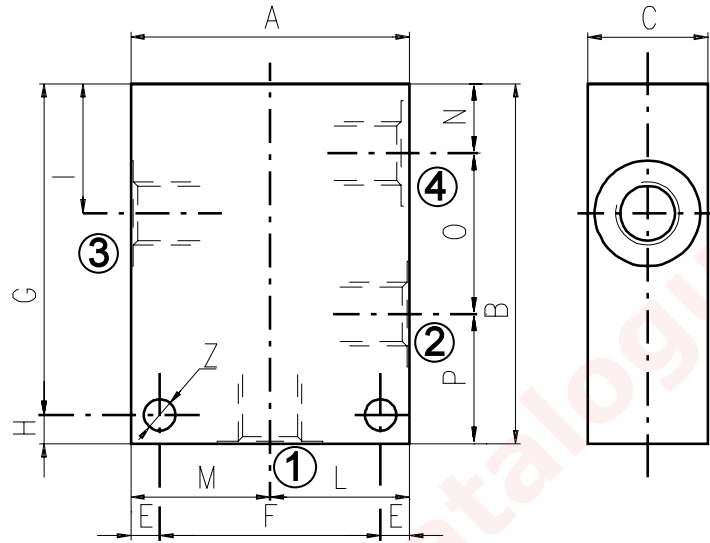

Cavity	Ports		A	B	C	E	F	G	H	I	L	M	N	O	P	Z
SAE 8/4	G 1/4	mm	60	75	30	7	46	63	12	29,1	30	30	14,8	29,1	31,1	6,5
		in	2.36	2.95	1.18	0.27	1.81	2.48	0.47	1.14	1.18	1.18	0.58	1.14	1.22	0.25
	SAE6	mm	60	75	30	7	46	63	12	29,1	30	30	14,8	29,1	31,1	6,5
		in	2.36	2.95	1.18	0.27	1.81	2.48	0.47	1.14	1.18	1.18	0.58	1.14	1.22	0.25
SAE 10/4	G 3/8	mm	60	85	35	6	48	79	6	34,5	30	30	18,8	31,7	34,5	7
		in	2.36	3.35	1.38	0.24	1.89	3.11	0.24	1.36	1.18	1.18	0.74	1.25	1.36	0.27
	G 1/2	mm	70	85	35	6	58	79	6	34,5	35	35	18,8	31,7	34,5	7
		in	2.75	3.35	1.38	0.24	2.28	3.11	0.24	1.36	1.38	1.38	0.74	1.25	1.36	0.27
	SAE6	mm	60	85	35	6	48	79	6	34,5	30	30	18,8	31,7	34,5	7
		in	2.36	3.35	1.38	0.24	1.89	3.11	0.24	1.36	1.18	1.18	0.74	1.25	1.36	0.27
SAE8	mm	70	85	35	6	58	79	6	34,5	35	35	18,8	31,7	34,5	7	
	in	2.75	3.35	1.38	0.24	2.28	3.11	0.24	1.36	1.38	1.38	0.74	1.25	1.36	0.27	
SAE 12/4	G 1/2	mm	80	115	40	8	64	107	8	44	40	40	22	44,5	48,5	8,5
		in	3.15	4.53	1.57	0.31	2.52	4.21	0.31	1.73	1.57	1.57	0.87	1.75	1.9	0.33
	SAE10	mm	80	115	40	8	64	107	8	44	40	40	22	44,5	48,5	8,5
		in	3.15	4.53	1.57	0.31	2.52	4.21	0.31	1.73	1.57	1.57	0.87	1.75	1.9	0.33
SAE 16/4	G 3/4	mm	100	130	50	10	80	120	10	53,5	50	50	25,1	56,9	48	10,5
		in	3.94	5.12	1.97	0.39	3.15	4.72	0.39	2.11	1.97	1.97	0.99	2.24	1.89	0.41

3/CC /- □ □ /40/□- □-1

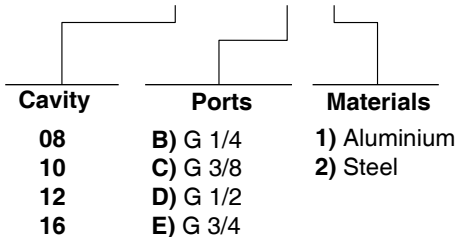

# Informations

## How to order valves with body

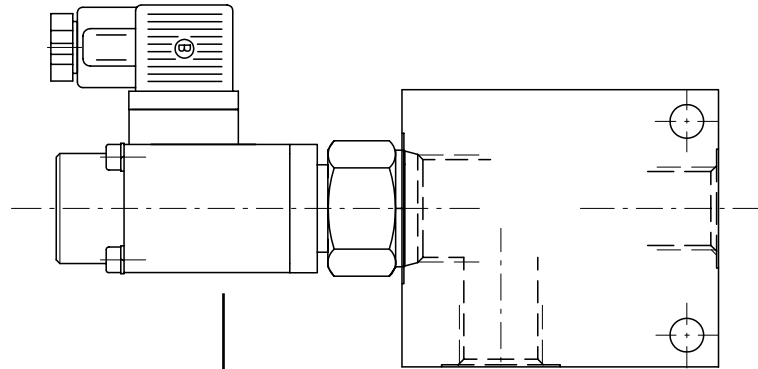

CARTRIDGE CODE

**PU-10-W/A-2-0B/**

BILLET CODE

**K- 1-1**

Cavità	Attacchi	Materiali
08	B) G 1/4	1) Aluminium
10	C) G 3/8	
12	D) G 1/2	
16	E) G 3/4	
	F) G 1	
	J) SAE 6	2) Steel
	K) SAE 8	
	L) SAE 10	
	M) SAE 12	
	N) SAE 16	

VARIATION "A": the dimensions with "\*" are related to the variation "A". Features of variation "A" are required only if noted on specific product catalogue page.

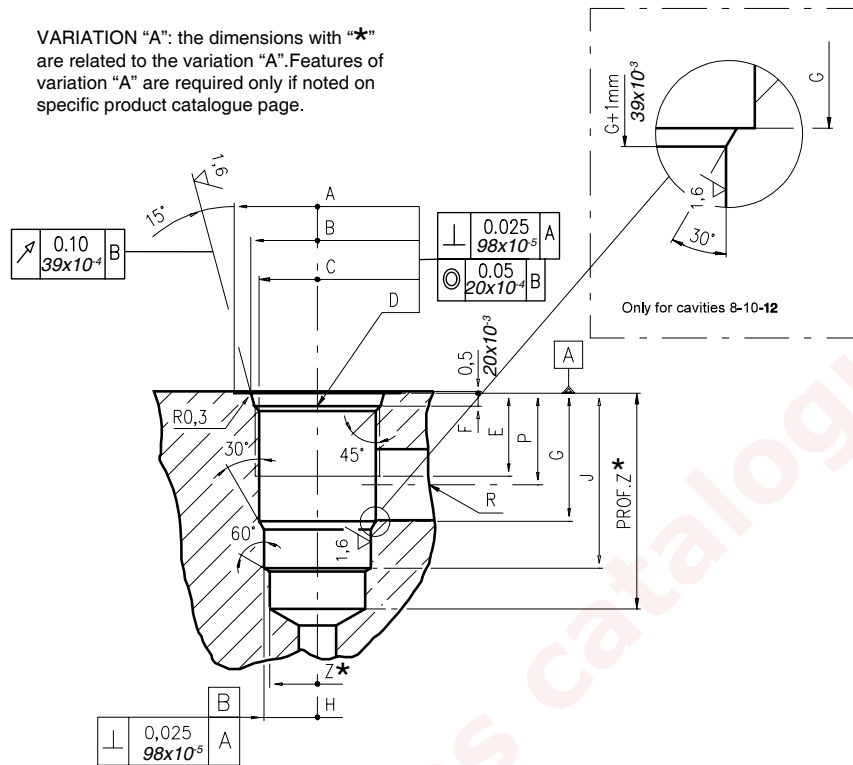

\		A	B ±0,05	C ±0,05	D	E	F	G	H ±0,02	J	K ±0,02	L ±0,02	M ±0,02	N	P	R øMAX	S	T øMAX	U	V øMAX	X øMAX	Z* øMIN	Prof.Z MIN*
		mm	in	mm	in	mm	in	mm	in	mm	in	mm	in	mm	in	mm	in	mm	in	mm	in	mm	in
08/2	mm	27	20,66	17,42	3/4-16 UNF	12,50	2,50	18,20	12,72	29,50	-	-	-	-	14,00	8,00	-	-	-	-	-	12,00	39
	in	1,06	0,81	0,68		0,49	0,10	0,72	0,50	1,16	-	-	-	-	0,55	0,31	-	-	-	-	-	0,47	1,53
10/2	mm	30	24,00	20,62	7/8-14 UNF	16,00	2,80	24,00	15,90	33,50	-	-	-	-	18,30	11,00	-	-	-	-	-	14,50	40
	in	1,18	0,94	0,81		0,63	0,11	0,94	0,62	1,32	-	-	-	-	0,72	0,43	-	-	-	-	-	0,57	1,57
12/2	mm	38	29,23	24,73	1 1/16-12 UNF	19,00	3,50	34,15	22,25	46,80	-	-	-	-	24,50	19,00	-	-	-	-	-	21,50	60
	in	1,50	1,15	0,97		0,75	0,14	1,34	0,87	1,84	-	-	-	-	0,96	0,75	-	-	-	-	-	0,85	2,36
16/2	mm	45	35,58	31,34	1 5/16-12 UNF	22,00	3,50	34,00	28,62	47,00	-	-	-	-	24,50	19,00	-	-	-	-	-	25,50	70
	in	1,77	1,40	1,23		0,87	0,14	1,34	1,13	1,85	-	-	-	-	0,96	0,75	-	-	-	-	-	1,00	2,75

Rougher tool

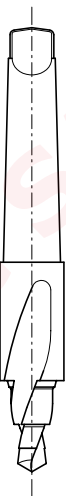

Cavity	Code number
08/2	3UT00053190
10/2	3UT00056610
12/2	3UT00054090
16/2	3UT00054510

Finisher tool

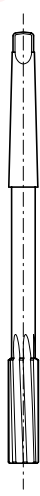

Cavity	Code number
08/2	3UT06A1270N
10/2	3UT00054580
12/2	3UT00054670
16/2	3UT00054520

Tap

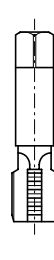

Cavity	Code number
08/2	3UT03416UNF
10/2	3UT07814UNF
12/2	3UT0111612UN
16/2	3UT0151612UN

Cavity plugs

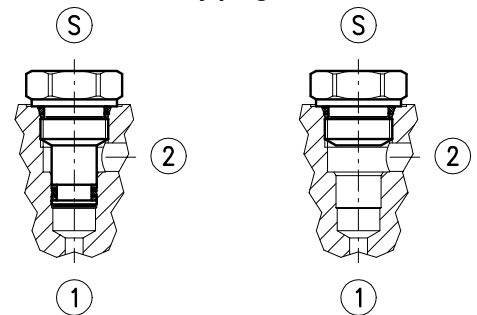

Cavity	Code number	①	②	Ⓢ
08/2	3XTP3533700	X	X	X
	4TP5531500	0	0	X
10/2	3XTP3544200	X	X	X
	3XTP1542300	0	0	X
12/2	3XTP3555400	X	X	X
	3XTP1552900	0	0	X
16/2	3XTP3575500	X	X	X
	3XTP1572900	0	0	X

X=Closed 0=Open



### Dimensions

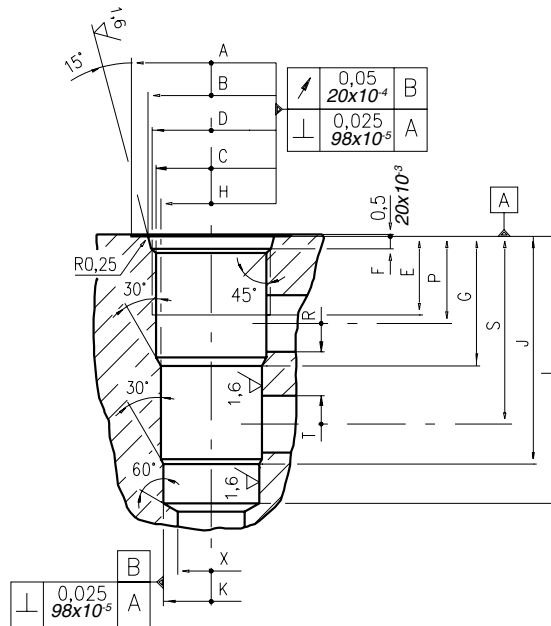

\	A	B ±0,05	C ±0,05	D	E	F	G	H ±0,02	J	K ±0,02	L	M ±0,02	N	P	R øMAX	S	T øMAX	U	V øMAX	X øMAX	Z øMIN	Prof. Z MIN	
08/3	mm	27	20,66	17,42	3/4-16 UNF	12,50	2,5	19,10	15,90	33,30	14,30	43,30	-	-	14,30	5,50	28,60	5,50	-	-	12,50	-	-
	in	1.06	0.81	0.68		0.49	0.10	0.75	0.62	1.31	0.56	1.70			0.56	0.22	1.12	0.22			0.49		
10/3	mm	30	24,00	20,62	7/8-14 UNF	16,00	2,80	23,10	17,50	39,60	15,90	47,60	-	-	18,30	6,50	34,00	6,50	-	-	14,00	-	-
	in	1.18	0.94	0.81		0.63	0.11	0.94	0.69	1.56	0.62	1.87			0.72	0.25	1.34	0.25			0.55		
12/3	mm	38	29,23	24,73	1 1/16-12 UNF	19,00	3,56	36,60	23,82	63,50	22,25	75,40	-	-	24,50	16,00	53,00	16,00	-	-	19,00	-	-
	in	1.50	1.15	0.97		0.75	0.14	1.44	0.94	2.5	0.88	2.97			0.96	0.63	2.09	0.63			0.75		
16/3	mm	45	35,6	31,34	1 5/16-12 UNF	22,00	3,5	36,50	28,62	64,30	27,02	75,38	-	-	24,60	16,00	53,00	16,00	-	-	19,00	-	-
	in	1.77	1.40	1.23		0.87	0.14	1.44	1.13	2.53	1.06	2.97			0.97	0.63	2.09	0.63			0.75		

#### Rougher tool

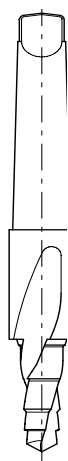

Cavity	Code number
08/3	3UT00052190
10/3	3UT00054170
12/3	3UT00054290
16/3	3UT00054470

#### Finisher tool



Cavity	Code number
08/3	3UT00052740
10/3	3UT00054180
12/3	3UT00054300
16/3	3UT00054480

#### Tap

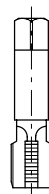

Cavity	Code number
08/3	3UT03416UNF
10/3	3UT07814UNF
12/3	3UT0111612UN
16/3	3UT0151612UN

#### Cavity plugs

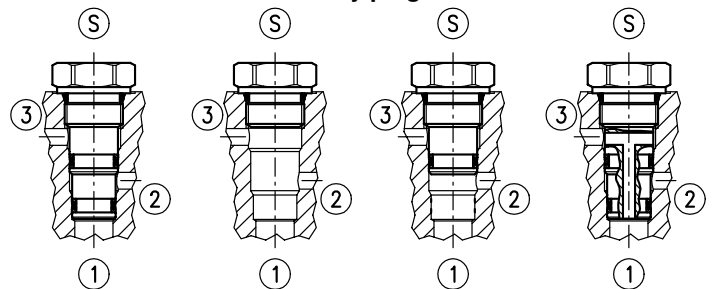

Cavity	Code number	①	②	③	Ⓢ
08/3	3XTP3535100	X	X	X	X
	4TP5531500	0	0	0	X
	3XTP3534000	0	0	X	X
	3XTP3534800	0	X	0	X
10/3	3XTP3545700	X	X	X	X
	3XTP1542300	0	0	0	X
	3XTP3545701	0	X	0	X
12/3	3XTP3558200	X	X	X	X
	3XTP1552900	0	0	0	X
	3XTP3558201	0	X	0	X
16/3	3XTP3578400	X	X	X	X
	3XTP1572900	0	0	0	X

X=Closed 0=Open

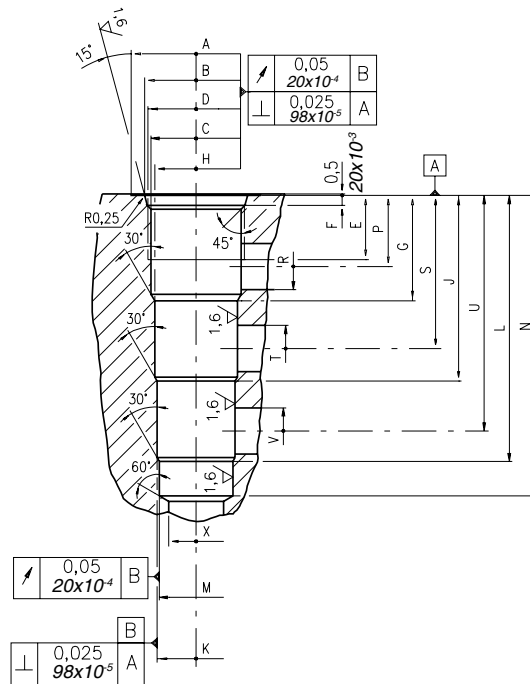

\	A	B ±0,05	C ±0,05	D	E	F	G	H ±0,02	J	K ±0,02	L	M ±0,02	N	P	R øMAX	S	T øMAX	U	V øMAX	X øMAX	Z ø MIN	Prof. Z MIN	
08/4	mm	28,00	20,66	17,42	3/4-16 UNF	12,50	2,50	19,10	15,90	33,30	14,30	47,60	12,72	57,60	14,30	5,50	28,60	5,50	42,90	5,50	11,00	-	-
	in	1.10	0.81	0.68		0.49	0.10	0.75	0.62	1.31	0.56	1.87	0.50	2.27	0.56	0.22	1.12	0.22	1.69	0.22	0.43	-	-
10/4	mm	30	24,00	20,62	7/8-14 UNF	16,00	2,80	23,60	19,08	39,60	17,50	55,40	15,90	63,50	18,30	6,50	34,00	6,50	50,00	6,50	14,00	-	-
	in	1.18	0.94	0.81		0.63	0.11	0.93	0.75	1.56	0.69	2.18	0.62	2.50	0.72	0.26	1.34	0.25	1.97	0.25	0.55	-	-
12/4	mm	38	29,23	24,73	1 1/16-12 UNF	19,00	3,56	29,50	23,82	51,50	22,25	73,60	20,65	83,33	21,50	11,00	43,50	11,00	66,00	11,00	19,00	-	-
	in	1.50	1.15	0.97		0.75	0.14	1.16	0.94	2.03	0.87	2.90	0.81	3.28	0.85	0.43	1.71	0.43	2.60	0.43	0.75	-	-
16/4	mm	45	35,60	31,34	1 5/16-12 UNF	22,00	3,50	36,50	28,62	64,30	27,02	92,07	25,45	104,00	24,60	16,00	53,00	16,00	81,50	16,00	19,00	-	-
	in	1.77	1.40	1.23		0.87	0.14	1.44	1.13	2.53	1.06	3.62	1.00	4.09	0.97	0.63	2.09	0.63	3.21	0.63	0.75	-	-

Rougher tool

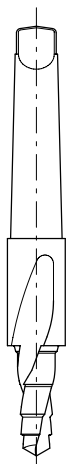

Cavity	Code number
08/4	3UT00052040
10/4	3UT00054250
12/4	3UT00054410
16/4	3UT00054820

Finisher



Cavity	Code number
08/4	3UT00052020
10/4	3UT00054260
12/4	3UT00054420
16/4	3UT00054830

Tap

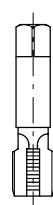

Cavity	Code number
08/4	3UT03416UNF
10/4	3UT07814UNF
12/4	3UT111612UN
16/4	3UT0151612UN

Cavity plugs

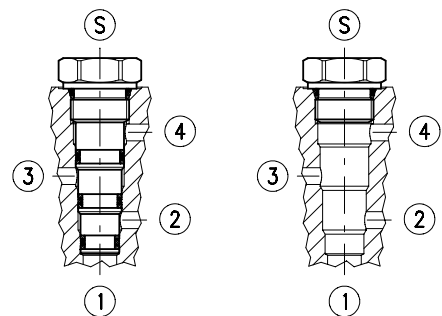

Cavity	Code number	①	②	③	④	Ⓢ
08/4	3XTP3536500	X	X	X	X	X
	4TP5531500	0	0	0	0	X
10/4	3XTP3548301	X	X	X	X	X
	3XTP1542300	0	0	0	0	X
12/4	3XTP3559300	X	X	X	X	X
	3XTP1552900	0	0	0	0	X
16/4	3XTP357B300	X	X	X	X	X
	3XTP1572900	0	0	0	0	X

X=Closed 0=Open

## Dimensions

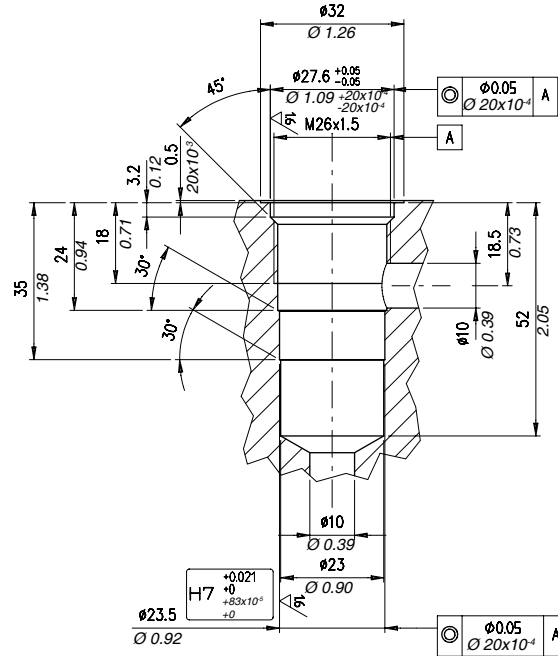

**Rougher tool**  
Code 3UT00050140

**Finisher**  
Code 3UT00055020

**Cavity plugs**  
Code 3UT08A26F150

