



# VR4M

## DIRECT CHECK VALVE

### SERIES 50

#### MODULAR VERSION

#### ISO 4401-05 (CETOP 05)

**p** max 320 bar  
**Q** max 100 l/min

#### MOUNTING INTERFACE

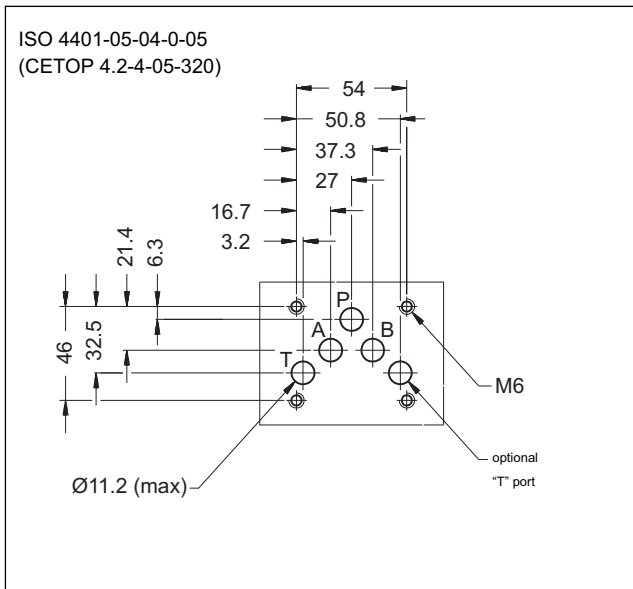

#### CONFIGURATIONS (see hydraulic symbols table)

- VR4M-SP: check valve on line P
- VR4M-ST: check valve on line T

#### PERFORMANCES (measured with mineral oil of viscosity 36cSt at 50°C)

Maximum operating pressure	bar	320
Check valve cracking pressure	bar	0,5 - 8
Maximum flow rate in the controlled lines and in the free lines	l/min	100
Ambient temperature range	°C	-20 / +50
Fluid temperature range	°C	-20 / +80
Fluid viscosity range	cSt	10 ÷ 400
Recommended viscosity	cSt	25
Degree of fluid contamination	According to ISO 4406:1999 class 20/18/15	
Mass	kg	2,3

#### OPERATING PRINCIPLE

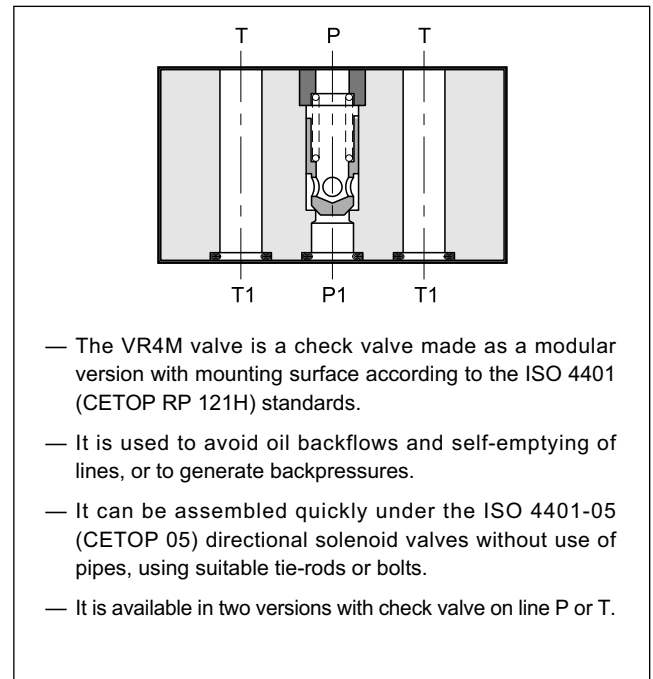

#### HYDRAULIC SYMBOLS

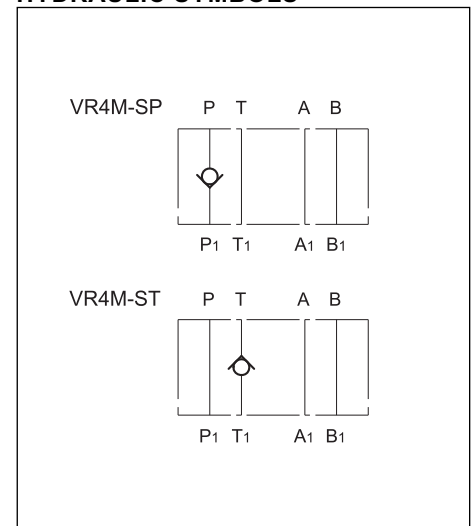

### 1 - IDENTIFICATION CODE

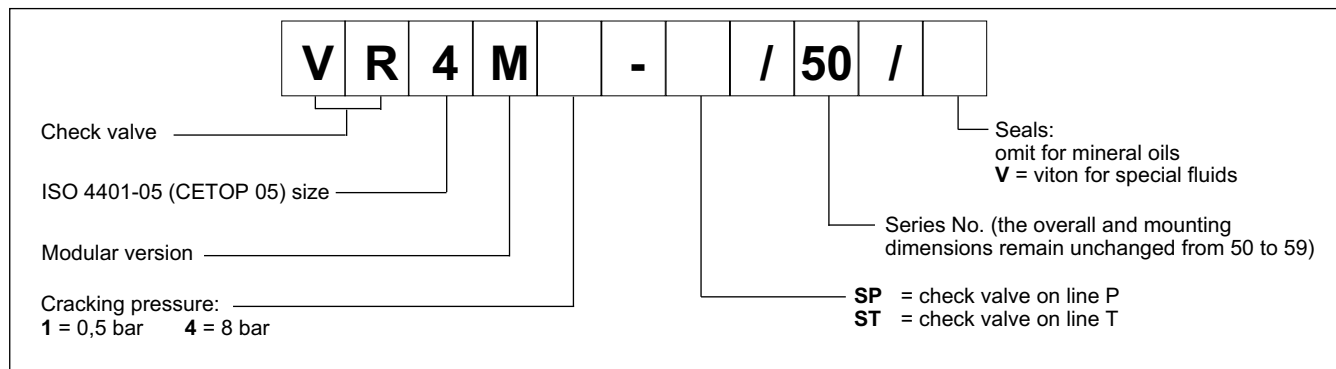

### 2 - CHARACTERISTIC CURVES (values obtained with viscosity of 36 cSt at 50°C)

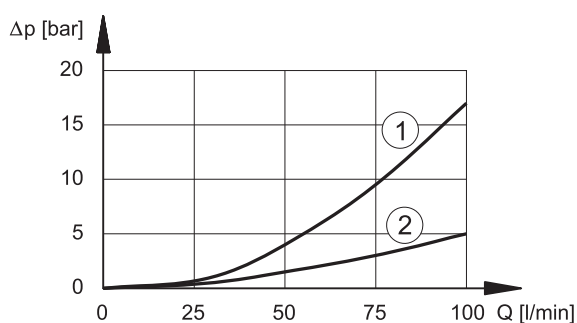

1) pressure drops  $P_1 \rightarrow P$  and  $T \rightarrow T_1$  (controlled lines)

2) pressure drops on free lines (ex.  $A \rightarrow A_1$ )

**NOTE:** Add the valve cracking pressure to the values shown by the curve 1 of the diagram

### 3 - HYDRAULIC FLUIDS

Use mineral oil-based hydraulic fluids HL or HM type, according to ISO 6743-4. For these fluids, use NBR seals. For fluids HFDR type (phosphate esters) use FPM seals (code V). For the use of other kinds of fluid such as HFA, HFB, HFC, please consult our technical department. Using fluids at temperatures higher than 80 °C causes a faster degradation of the fluid and of the seals characteristics. The fluid must be preserved in its physical and chemical characteristics.

### 4 - OVERALL AND MOUNTING DIMENSIONS

