

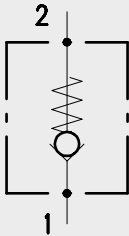

Check and Pilot check valves

Index

Hydraulic diagram	Type	Description	Maximum flow up to		Maximum pressure		Page
			l/min	US gpm	bar	psi	
	VUI	Poppet type	160	42	400	5800	9
	UC..A		100	26	350	5100	

Operation

Free oil flow is allowed from 1 to 2 while oil flow is stopped in the opposite direction.

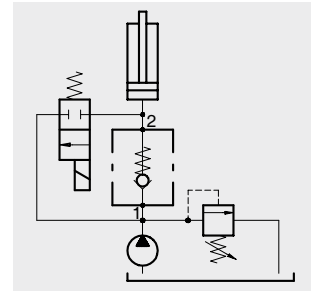
**Performance****Body Valves**

Type VUI	Maximum flow		Maximum pressure		Opening pressure from 1 to 2	Oil leak from 1 to 2	Weight		Cavities and tools
	l/min	US gpm	bar	psi			kg	lb	
VUI 38	25	6.6	400	5800	0,5 - 5 bar 7.3 - 72.5 psi	0,10 cm ³ /min. - 61x10 ⁻⁴ in ³ /min. (2 drops) at 210 bar -3050 psi	0,08	0.18	see cavity VUI 38 page 107
VUI 12	40	10.5					0,15	0.33	see cavity VUI 12 page 108
VUI 34	100	26					0,30	0.66	see cavity VUI 34 page 109
VUI 100	160	42					0,54	1.19	see cavity VUI 100 page 110

Cartridges

Type UC	Maximum flow		Maximum pressure		Opening pressure from 1 to 2	Oil leak from 1 to 2	Weight		Cavities and tools
	l/min	US gpm	bar	psi			kg	lb	
UC08A	20	5.3	350	5100	0,5 - 2,5 - 5 bar 7.3 - 36.2 - 72.5 psi	0,10 cm ³ /min. - 61x10 ⁻⁴ in ³ /min. at 210 bar -3050 psi	0,08	0.18	see cavity SAE 8-2 page 104
UC10A	35	9.2					0,09	0.20	see cavity SAE 10-2 page 104
UC12A	50	13					0,18	0.40	see cavity SAE 12-2 page 104
UC16A	100	26					0,37	0.81	see cavity SAE 16-2 page 104

Dimensions and hydraulic circuit

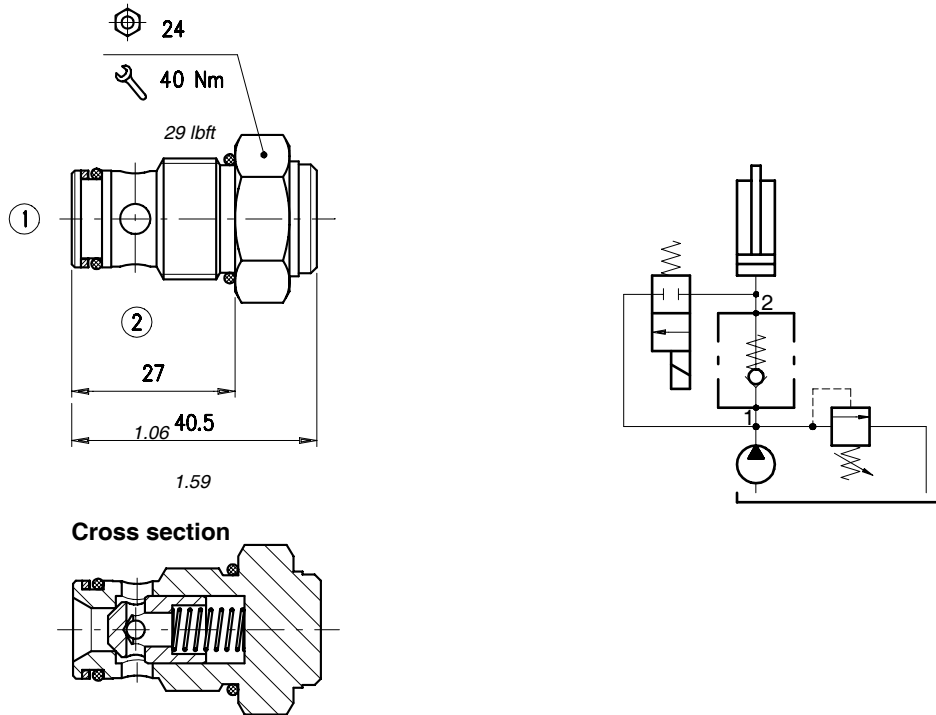

Rating diagrams

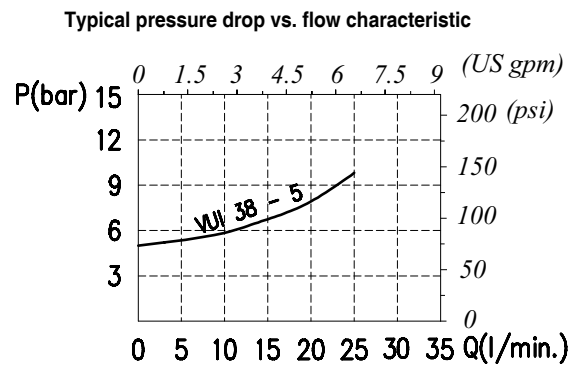
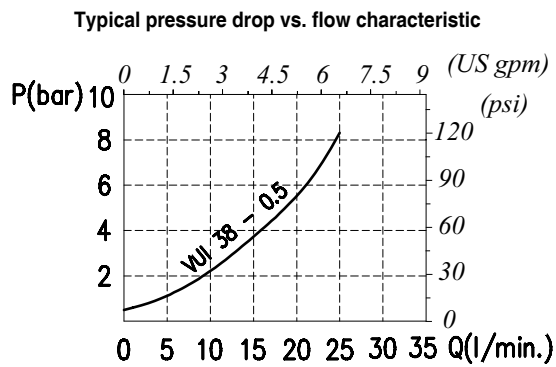

Order code

VUI 38 / □□

Opening pressure from 1 to 2

Pa. 0,5) 0,5 bar (7.3 psi)
Pa. 5) 5 bar (72.5 psi)

Dimensions and hydraulic circuit

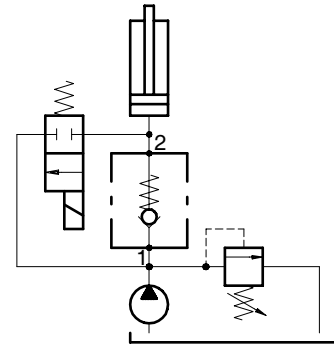
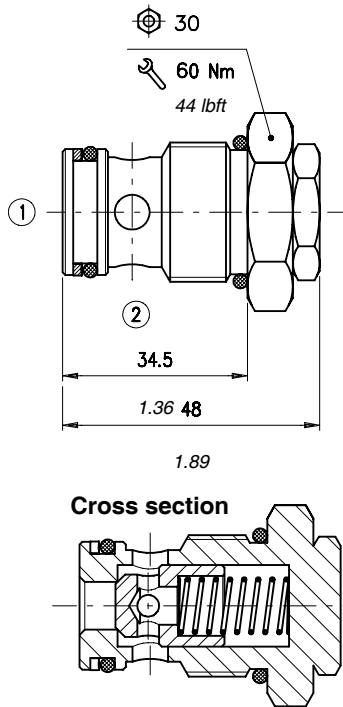

Rating diagrams

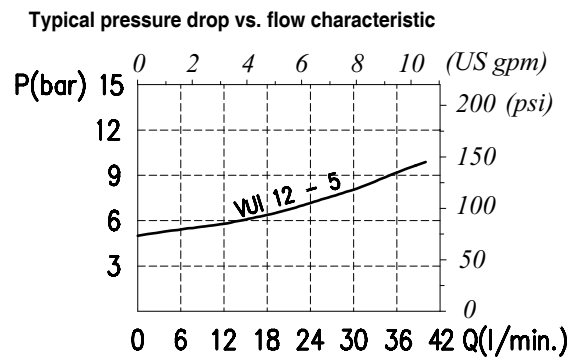
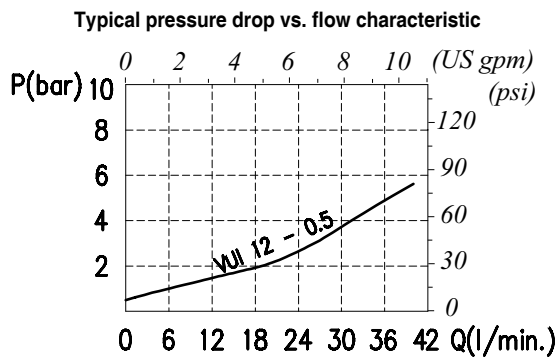

Order code

VUI 12 / □□

Opening pressure from 1 to 2

Pa. 0,5) 0,5 bar (7.3 psi)
Pa. 5) 5 bar (72.5 psi)

Dimensions and hydraulic circuit

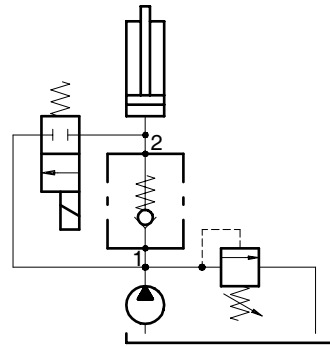
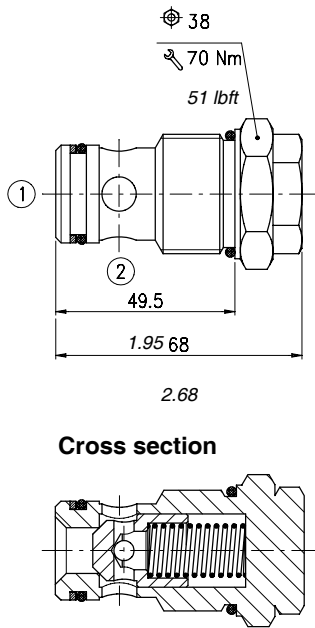

Rating diagrams

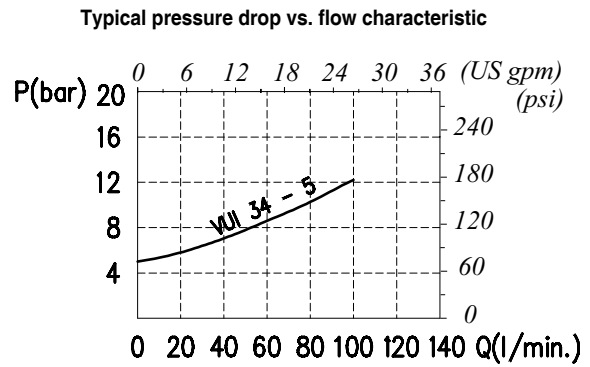
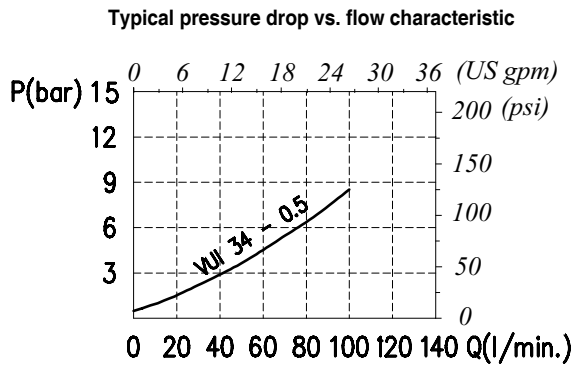

Order code

VUI 34 / □□

Opening pressure from 1 to 2

Pa. 0,5) 0,5 bar (7.3 psi)
Pa. 5) 5 bar (72.5 psi)

Dimensions and hydraulic circuit

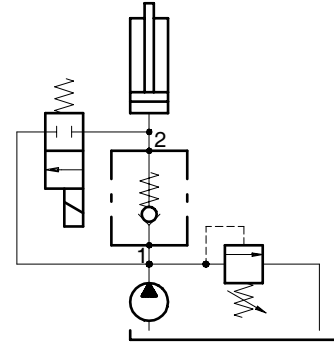
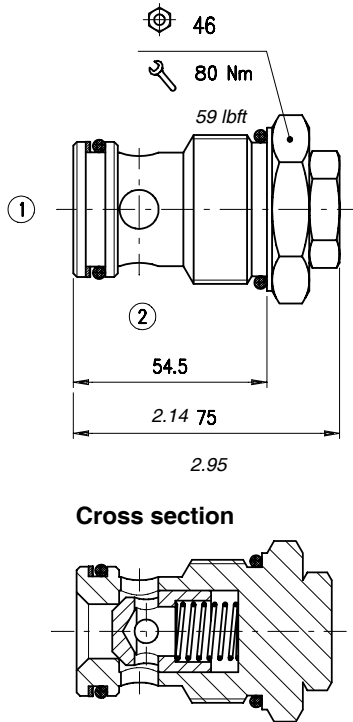

Rating diagrams

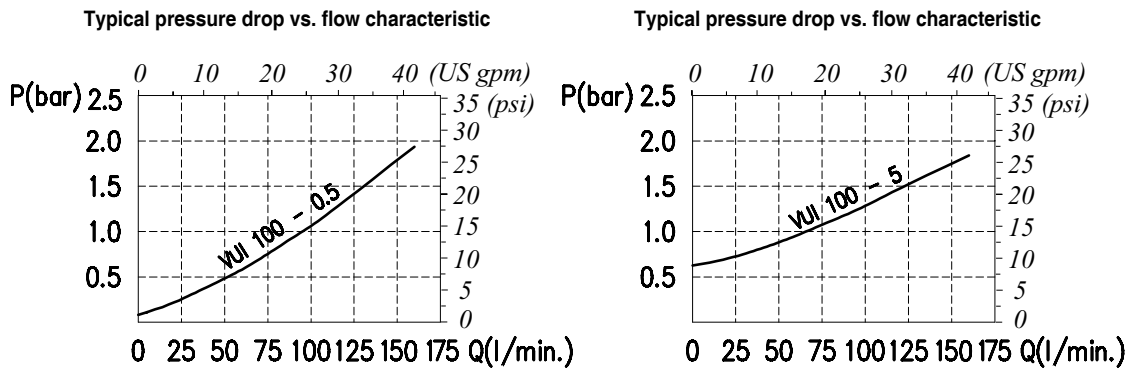

Order code

VUI 100 / □□

Opening pressure from 1 to 2

Pa. 0,5) 0,5 bar (7.3 psi)
Pa. 5) 5 bar (72.5 psi)

Dimensions and hydraulic circuit

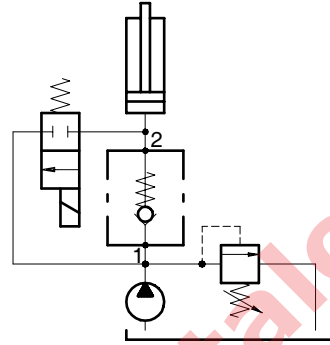
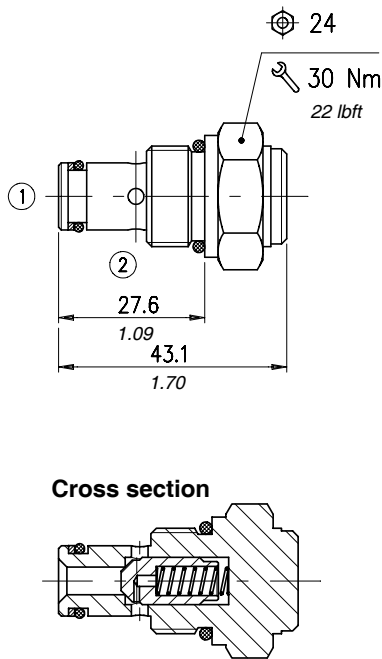

Rating diagrams

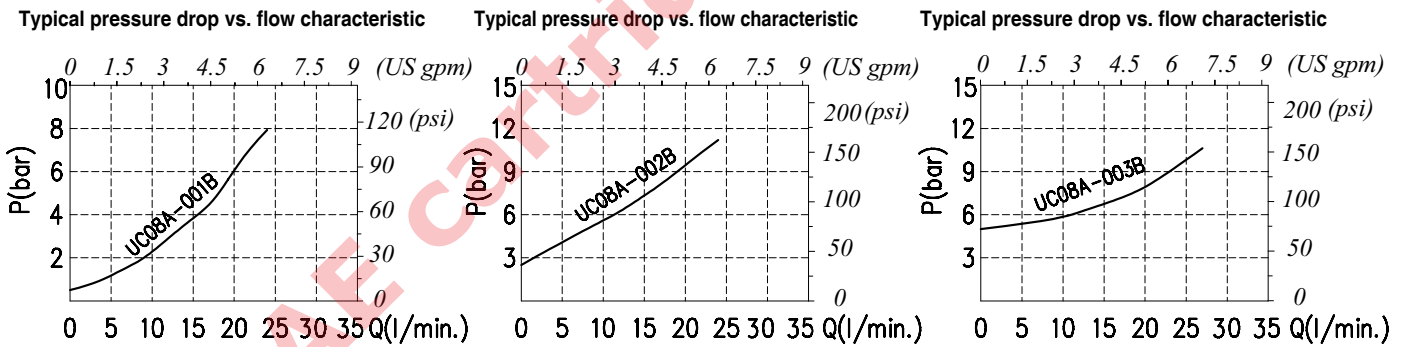

Order code

UC08A / 0 -0 -□ -□

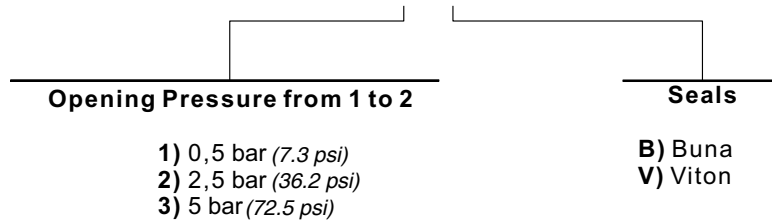

Dimensions and hydraulic circuit

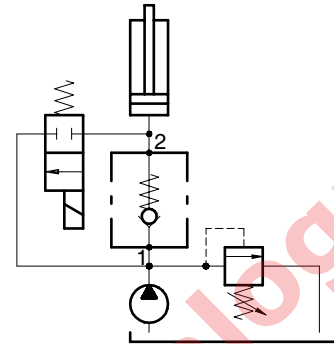
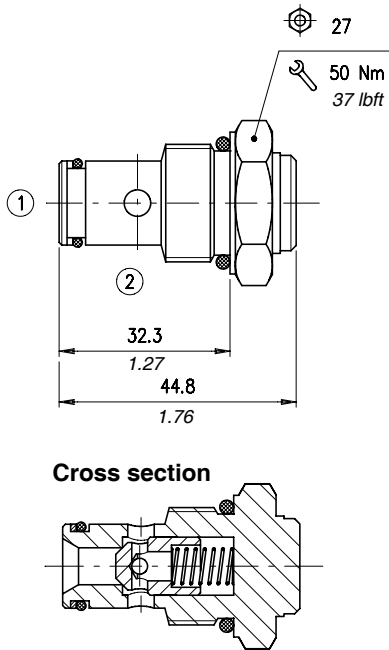

Rating diagrams

Typical pressure drop vs. flow characteristic

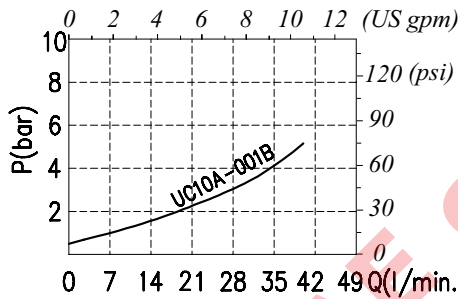

Typical pressure drop vs. flow characteristic

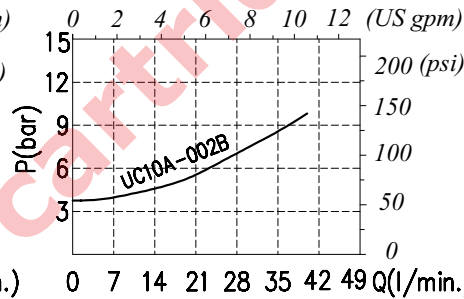

Typical pressure drop vs. flow characteristic

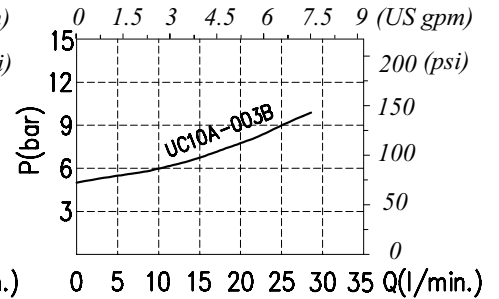

Order code

UC10A / 0 -0 -□ -□

Opening Pressure from 1 to 2

- 1) 0,5 bar (7.3 psi)
- 2) 2,5 bar (36.2 psi)
- 3) 5 bar (72.5 psi)

Seals

- B) Buna
- V) Viton

Dimensions and hydraulic circuit

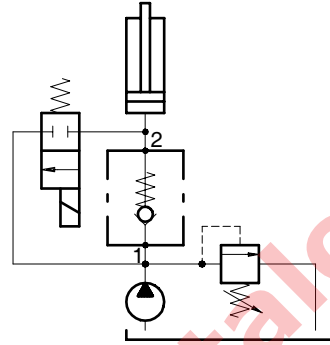
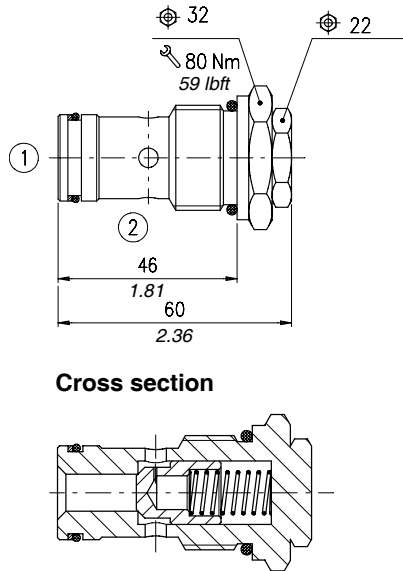

Rating diagrams

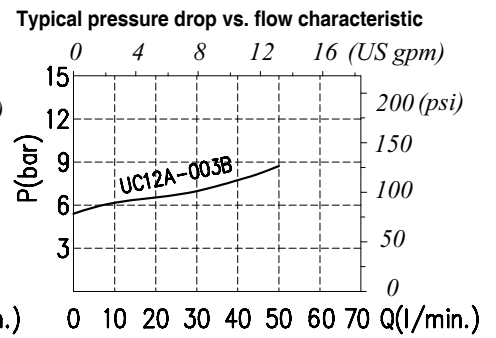
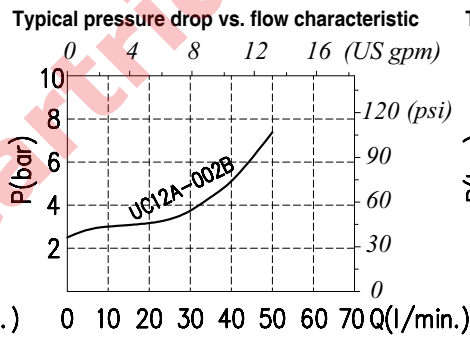
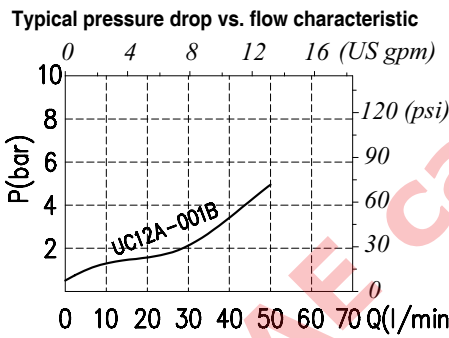

Order code

UC12A / 0 -0 -□ -□

Opening Pressure from 1 to 2

Seals

- 1) 0,5 bar (7.3 psi)
- 2) 2,5 bar (36.2 psi)
- 3) 5 bar (72.5 psi)

- B) Buna
- V) Viton

Dimensions and hydraulic circuit

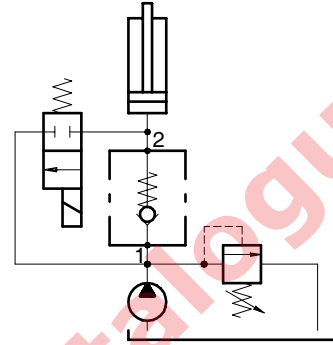
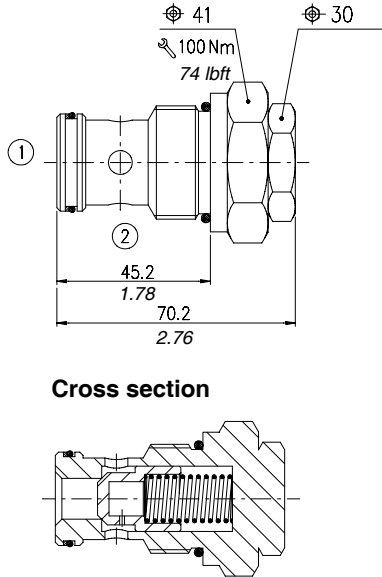

Rating diagrams

Typical pressure drop vs. flow characteristic

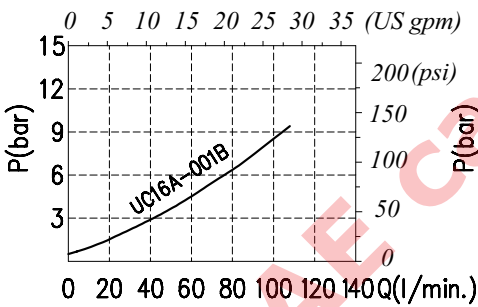

Typical pressure drop vs. flow characteristic

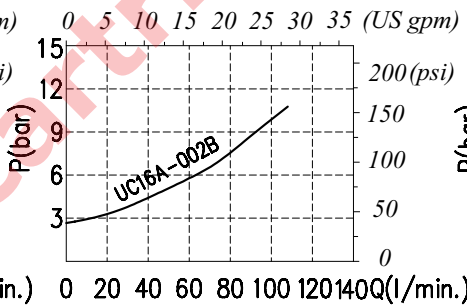

Typical pressure drop vs. flow characteristic

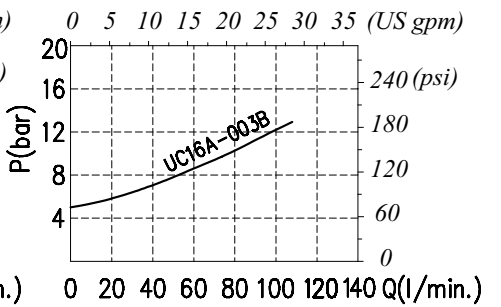

Order code

UC16A / 0 -0 -□ -□

Opening Pressure from 1 to 2

- 1) 0,5 bar (7.3 psi)
- 2) 2,5 bar (36.2 psi)
- 3) 5 bar (72.5 psi)

Seals

- B) Buna
- V) Viton

Operation

Multiple coil versions are available to allow use with direct and alternated current.

Thermal insulation class: F (Tmax = 155°C) – (VDE 0580)

Relative duty cycle: ED 100% (VDE 0580)

To assure ED = 100% and perform continuous coil operation, the following conditions should be met:

$T_A + \Delta T < T_{max}$

Whereas:

- T_A = ambient temperature

- ΔT = temperature increase due to operation

- T_{max} = maximum admissible temperature according to insulation class

We therefore recommend always checking that the maximum ambient temperature is same as $T_{max} - \Delta T$ (providing no special operating requirement are there).

Safety standards (DIN 40050): IP54 without connector

IP65 with connector

Admissible voltage range for long lasting and trouble free operations life: nominal voltage $\pm 10\%$

Performance

Type	Resistance Ω $T_A = 20^\circ\text{C}$ 68°F	Current (A)		Power (W) or (VA) Cold	ΔT	
		Cold	Warm		After 1 hour at: - $T_A = 20-25^\circ\text{C}$ 68-77°F -Nominal voltage	
					C°	F°
BE 12 Vcc	7,7	1,56	1,16	18,7 W	110	230
BE 24 Vcc	31	0,77	0,58	18,6 W	110	230
BE 48 Vcc	116	0,41	0,3	19,8 W	115	238
BE 110 Vcc	700	0,157	0,12	17,3 W	105	221
BE 24 Vca (50 Hz)	5,3	1,16	0,87	28 VA	105	221
BE 48 Vca (50 Hz)	21,3	0,6	0,45	28,8 VA	105	221
BE 110 Vca (50 Hz)	108	0,26	0,19	28,6 VA	105	221
BE 220 Vca (50 Hz)	438	0,13	0,09	28,6 VA	105	221
BE 380 Vca (50 Hz)	1400	0,09	0,06	34,2 VA	105	221
BE 24 RAC	27	0,8	0,6	17,3 W	105	221
BE 110 RAC	630	0,157	0,12	15,6 W	100	212
BE 220 RAC	2500	0,08	0,06	15,7 W	100	212
BT 12 Vcc	6,8	1,77	1,15	21 W	-	-
BT 24 Vcc	27	0,89	0,58	21 W	-	-
BT 48 Vcc	110	0,43	0,32	20,3 W	105	221
BT 110 Vcc	700	0,15	0,11	15,7 W	100	212
BT 24 Vca (50 Hz)	4,2	0,94	0,83	22,6 VA	-	-
BT 48 Vca (50 Hz)	15,3	0,73	0,54	35 VA	105	221
BT 110 Vca (50 Hz)	89	0,21	0,18	23,1 VA	-	-
BT 220 Vca (50 Hz)	350	0,1	0,08	22 VA	-	-
BT 24 RAC	90	0,47	0,37	20,7 W	105	221
BT 110 RAC	540	0,2	0,16	21,6 W	110	230
BT 220 RAC	2170	0,1	0,08	21,7 W	105	221

Dimensions

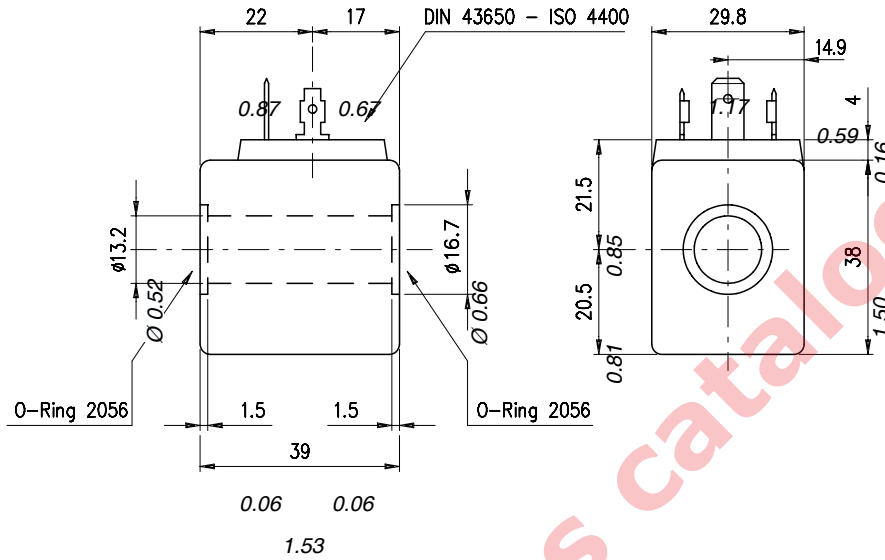

Order code

Type	Ordering code	Ordering code with standard connector	Standard connector code	Connector page
BE 12 Vcc	4SL1000120	5SL1000120	4CN1009990	Page 97 (CC-CA)
BE 24 Vcc	4SL1000240	5SL1000240		
BE 48 Vcc	4SL1000480	5SL1000480		
BE 110 Vcc	4SL1001100	5SL1001100		
BE 24 Vca (50 Hz)	4SL1010240	5SL1010240		
BE 48 Vca (50 Hz)	4SL1010480	5SL1010480		
BE 110 Vca (50 Hz)	4SL1011100	5SL1011100		
BE 220 Vca (50 Hz)	4SL1012200	5SL1012200		
BE 380 Vca (50 Hz)	4SL1013800	5SL1013800	4CN1010240	Page 97 (CL)
BE 24 RAC	4SL1030240	5SL1030240		
BE 110 RAC	4SL1031100	5SL1031100		
BE 220 RAC	4SL1032200	5SL1032200		

Dimensions

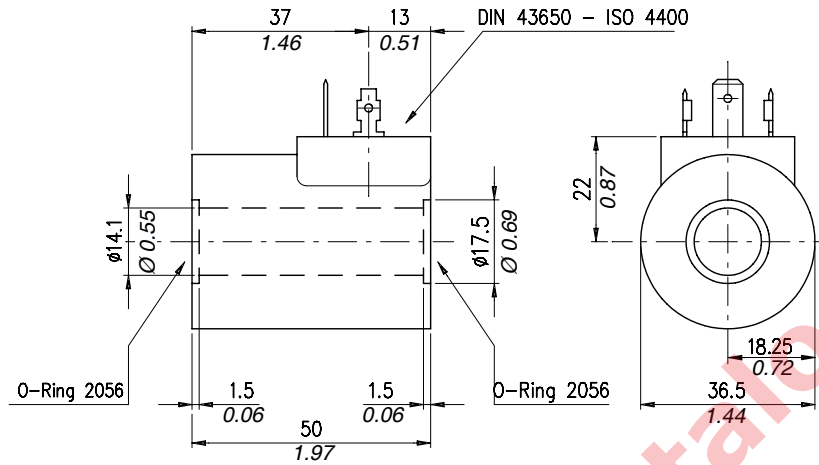

Order code

Type	Ordering code	Ordering code with standard connector	Standard connector code	Connector page
BT 12 Vcc	4SL3000120	5SL3000120	4CN1009990	Page 97 (CC-CA)
BT 24 Vcc	4SL3000240	5SL3000240		
BT 48 Vcc	4SL3000480	5SL3000480		
BT 110 Vcc	4SL3001100	5SL3001100		
BT 24 Vca (50 Hz)	4SL3010240	5SL3010240		
BT 48 Vca (50 Hz)	4SL3010480	5SL3010480		
BT 110 Vca (50 Hz)	4SL3011100	5SL3011100		
BT 220 Vca (50 Hz)	4SL3012200	5SL3012200	4CN3010240	Page 97 (CP)
BT 24 RAC	4SL3030240	5SL3030240		
BT 48 RAC	4SL3030480	5SL3030480		
BT 110 RAC	4SL3031100	5SL3031100		
BT 220 RAC	4SL3032200	5SL3032200	4CN3012200	

Operation

Proportional coil. 12 and 24 coils direct voltage, supply a force proportional to the current amount.

thermal insulation class: F (TMAX = 155 °C) - (VDE 0580).

Relative duty cycle: ED = 100 % (VDE 0580).

To assure ED=100% and perform continuous coil operation, the following conditions should be met:

$T_A + \Delta T < T_{MAX}$

T_A = ambient temperature; ΔT = a temperature increase due to operation; T_{MAX} = maximum admissible temperature according to insulation class.

We therefore recommend always checking that the maximum ambient temperature is same as $T_{max} - \Delta T$ (providing no special operating requirement are there).

Safety standards (DIN40050): IP 54 without connector

IP 65 with connector

Admissible voltage range for long lasting and trouble free operations life: nominal voltage $\pm 10\%$

Current Hysteresis: $< 2,5\%$

Force Hysteresis: $< 2\%$

Performance

Voltage [Volt]	Resistance [Ω]	Current [A]		Power [W]		ΔT [C°] After 1 hour at: $T_a=20-25^\circ C$ 68-77°F -Nominal voltage	Weight	
	$T_a=20^\circ C$ 68°F	cold	warm	nom.	lim.		kg	lb
(35x35) 12	7,2	1,25		11,2	17,4	120	0,43	0.95
(35x35) 24	24,6	0,68		11,4				
(45x45) 12	4,3	1,78		13,6	20,8		0,75	1.65
(45x45) 24	21	0,81		13,8				

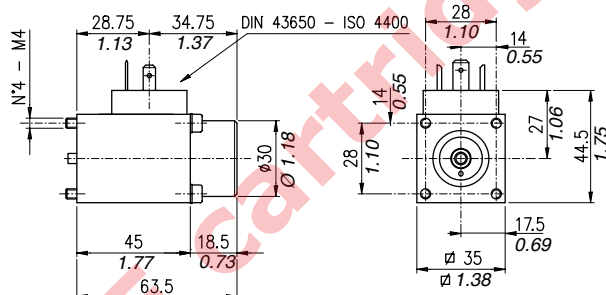

P.C. 35X35

Type	Ordering code	Ordering code with standard connector	Standard connector code	Connector page
35x35 12 Vcc	4SL4000120	5SL4000120	4CN1009990	see page 97 (CC-CA)
35x35 24 Vcc	4SL4000240	5SL4000240		

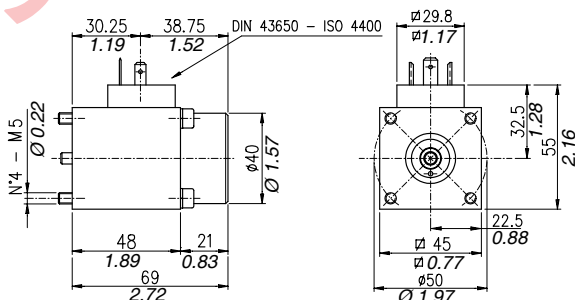

P.C. 45X45

Type	Ordering code	Ordering code with standard connector	Standard connector code	Connector page
45x45 12 Vcc	4SL4000243	5SL4000243	4CN1009990	see page 97 (CC-CA)
45x45 24 Vcc	4SL4000241	5SL4000241		

Operation

There are 3 types of different solenoid connectors:

"CC-CA" 2-poles + GROUND electric connectors in compliance with DIN and A/ISO standards 43650 and 4400. Electric connectors suitable for connection of DC and AC current coils. Type of current must be same as for the coil used.

"CL" 2-poles + rectifier + GROUND electric connectors in compliance with DIN and A/ISO standards 43650 and 4400.

Electric connectors suitable for connection of DC current coils BE...RAC. AC current operation only. Use of these poles depends on the type of valve used.

"CP" 2-poles + rectifier + GROUND electric connectors in compliance with DIN and A/ISO standards 43650 and 4400.

Electric connectors suitable for connection of DC current coils BT...RAC. AC current operation only. Use of these poles depends on the type of valve used.

Performance

Type	Nominal voltage	Maximum capacity of in-built diode	Nominal poles voltage	Max poles voltage	Poles resistance	Max poles section	Cable size options	Cable diameter	Safety standards	Insulation index
CC-CA	AC	-	10 A	16 A	≤ 4 m Ohm	1,5 mm ² 0.002in ²	Pg09	6-8 mm 0.24-0.31 in	IP65 (DIN 40050)	VDE0110-1/89
CL	max 250 V DC	1 A								
CP	max 300 V	3 A								

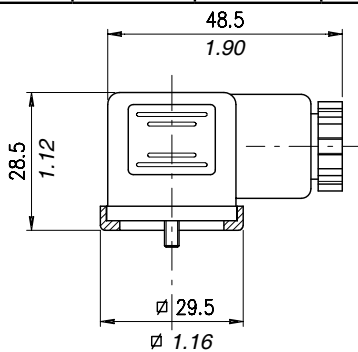

code number CC-CA Connector

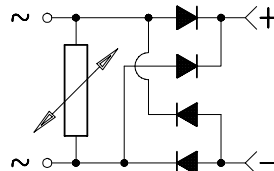
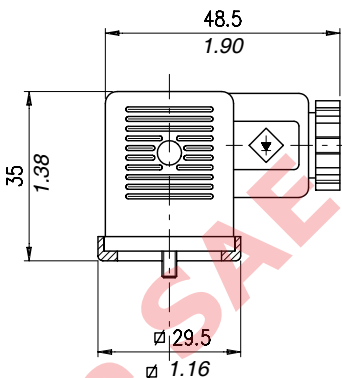

code number CL Connector

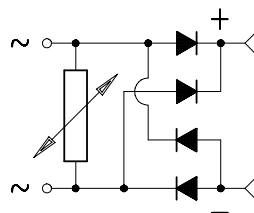
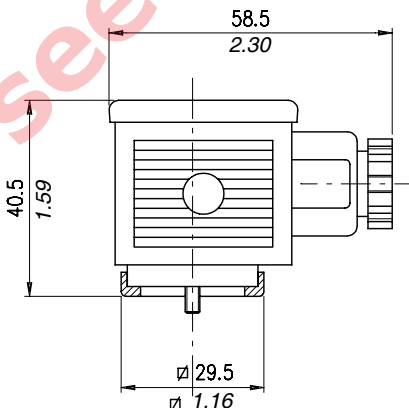

code number CP Connector

Dimensions

Material	Max. pressure	
	bar	psi
Alluminium	210	3050
Steel	350	5100

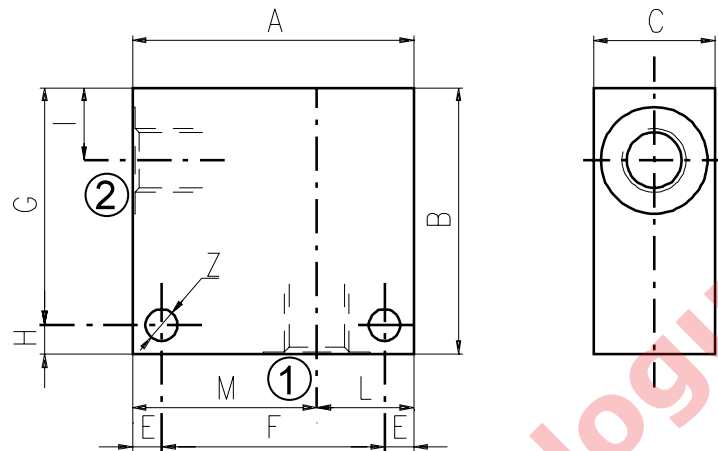

Cavità	Attacchi	A	B	C	E	F	G	H	I	L	M	Z	
SAE 8/2	G 1/2	mm	70	65	35	7	56	53	12	14,5	35	35	6,5
		in	2.75	2.56	1.38	0.27	2.20	2.09	0.47	0.57	1.38	1.38	0.25
	G 1/4	mm	50	50	30	6	38	44	6	14,8	20	30	6,5
		in	1.97	1.97	1.18	0.24	1.50	1.73	0.24	0.58	0.79	1.18	0.25
	G 3/8	mm	50	50	30	6	38	44	6	14,8	20	30	6,5
		in	1.97	1.97	1.18	0.24	1.50	1.73	0.24	0.58	0.79	1.18	0.25
	SAE6	mm	50	50	30	6	38	44	6	14,8	20	30	6,5
		in	1.97	1.97	1.18	0.24	1.50	1.73	0.24	0.58	0.79	1.18	0.25
SAE 10/2	G 1/4	mm	60	60	35	6	48	54	6	18,8	25	35	6,5
		in	2.36	2.36	1.38	0.24	1.89	2.12	0.24	0.74	0.98	1.38	0.25
	G 3/8	mm	60	60	35	6	48	54	6	18,8	25	35	6,5
		in	2.36	2.36	1.38	0.24	1.89	2.12	0.24	0.74	0.98	1.38	0.25
	G 1/2	mm	60	60	35	6	48	54	6	18,8	25	35	6,5
		in	2.36	2.36	1.38	0.24	1.89	2.12	0.24	0.74	0.98	1.38	0.25
	SAE8	mm	60	70	35	6	48	64	6	18,8	25	35	6,5
		in	2.36	2.75	1.38	0.24	1.89	2.52	0.24	0.74	0.98	1.38	0.25
	SAE10	mm	70	70	35	6	58	64	6	18,5	35	35	6,5
		in	2.75	2.75	1.38	0.24	2.28	2.52	0.24	0.73	1.38	1.38	0.25
	SAE12	mm	70	70	40	8	54	62	8	22	30	40	8,5
		in	2.75	2.75	1.57	0.31	2.12	2.44	0.31	0.87	1.18	1.57	0.33
SAE 12/2	G 1/2	mm	70	80	40	8	54	72	8	25	30	40	8,5
		in	2.75	3.15	1.57	0.31	2.12	2.83	0.31	0.98	1.18	1.57	0.33
	G 3/4	mm	70	90	40	8	54	82	8	25	30	40	8,5
		in	2.75	3.54	1.57	0.31	2.12	3.23	0.31	0.98	1.18	1.57	0.33
	SAE10	mm	70	85	40	8	54	77	8	25	30	40	8,5
		in	2.75	3.35	1.57	0.31	2.12	3.03	0.31	0.98	1.18	1.57	0.33
	SAE12	mm	70	85	40	8	54	77	8	25	30	40	8,5
		in	2.75	3.35	1.57	0.31	2.12	3.03	0.31	0.98	1.18	1.57	0.33

Dimensions

Cavity	Ports	A	B	C	E	F	G	H	I	L	M	Z	
SAE 16/2	G 1/2	mm	80	90	50	10	60	80	10	25	35	45	10,5
		in	3.15	3.54	1.97	0.39	2.36	3.15	0.39	0.98	1.38	1.77	0.41
	G 3/4	mm	80	90	50	10	60	80	10	25	35	45	10,5
		in	3.15	3.54	1.97	0.39	2.36	3.15	0.39	0.98	1.38	1.77	0.41
	G 1	mm	85	100	60	10	65	90	10	23,5	40	45	10,5
		in	3.35	3.94	2.36	0.39	2.56	3.54	0.39	0.92	1.57	1.77	0.41
	SAE12	mm	80	90	50	10	60	80	10	25	35	45	10,5
		in	3.15	3.54	1.97	0.39	2.36	3.15	0.39	0.98	1.38	1.77	0.41
	SAE16	mm	80	100	50	10	60	90	10	25	35	45	10,5
		in	3.15	3.94	1.97	0.39	2.36	3.54	0.39	0.98	1.38	1.77	0.41

Order code

3/CC /- □ □ /20/□ - □ -1

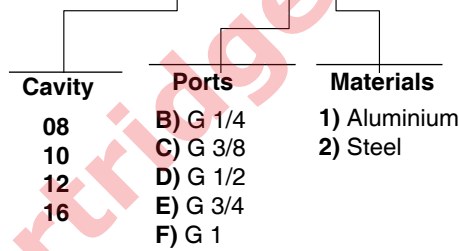

2, 3 and 4 way Valves Bodies

3 WAY BODIES

Dimensions

Material	Max. pressure bar	
	bar	psi
Alluminium	210	3050
Steel	350	5100

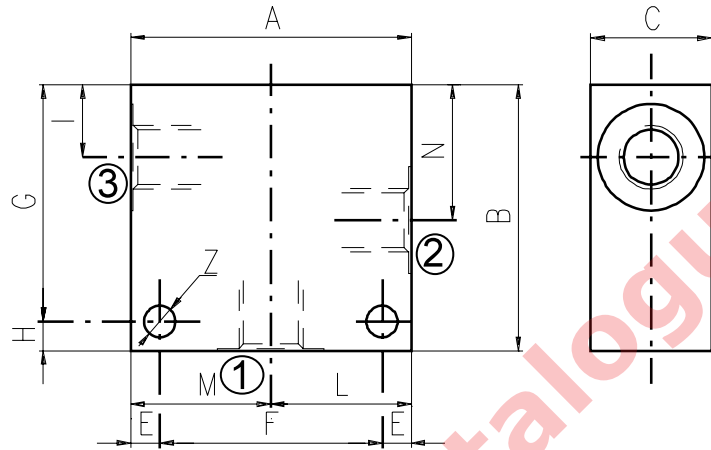

Cavity	Ports	A	B	C	E	F	G	H	I	L	M	N	Z	
SAE 8/3	G 1/4	mm	60	60	30	7	46	48	12	14,8	30	30	29,1	6,5
		in	2.36	2.36	1.18	0.27	1.81	1.89	0.47	0.58	1.18	1.18	1.14	0.25
	G 3/8	mm	60	60	30	7	46	48	12	14,5	30	30	29,1	6,5
		in	2.36	2.36	1.18	0.27	1.81	1.89	0.47	0.57	1.18	1.18	1.14	0.25
	G 1/2	mm	70	65	35	7	56	53	12	14,5	35	35	29,1	6,5
		in	2.75	2.56	1.38	0.27	2.20	2.09	0.47	0.57	1.38	1.38	1.14	0.25
SAE6	mm	60	60	30	7	46	48	12	14,5	30	30	29,1	6,5	
	in	2.36	2.36	1.18	0.27	1.81	1.89	0.47	0.57	1.18	1.18	1.14	0.25	
SAE 10/3	G 1/4	mm	60	65	35	6	48	59	6	18	30	30	34,5	7
		in	2.36	2.56	1.38	0.24	1.89	2.32	0.24	0.70	1.18	1.18	1.36	0.27
	G 3/8	mm	60	65	35	6	48	59	6	18,8	30	30	34,5	7
		in	2.36	2.56	1.38	0.24	1.89	2.32	0.24	0.74	1.18	1.18	1.36	0.27
	G 1/2	mm	65	70	35	6	53	64	6	18,8	32,5	32,5	34,5	7
		in	2.56	2.75	1.38	0.24	2.09	2.52	0.24	0.74	1.28	1.28	1.36	0.27
	SAE6	mm	65	70	35	6	53	64	6	18,8	32,5	32,5	34,5	7
		in	2.56	2.75	1.38	0.24	2.09	2.52	0.24	0.74	1.28	1.28	1.36	0.27
	SAE8	mm	65	70	35	6	53	64	6	18,8	32,5	32,5	34,5	7
		in	2.56	2.75	1.38	0.24	2.09	2.52	0.24	0.74	1.28	1.28	1.36	0.27
SAE 12/3	G 1/2	mm	70	100	40	8	54	92	8	25	35	35	53,5	8,5
		in	2.75	3.94	1.57	0.31	2.12	3.6	0.31	0.98	1.38	1.38	2.10	0.33
	G 3/4	mm	90	100	50	10	70	90	10	25,1	45	45	53,5	10,5
		in	3.54	3.94	1.97	0.39	2.75	3.54	0.39	0.99	1.77	1.77	2.11	0.41
	SAE10	mm	80	100	40	8	64	92	8	25	40	40	53,5	8,5
		in	3.15	3.94	1.57	0.31	2.52	3.6	0.31	0.98	1.57	1.57	2.11	0.33
	SAE12	mm	80	100	45	8	64	92	8	25	40	40	53,5	8,5
		in	3.15	3.94	1.77	0.31	2.52	3.6	0.31	0.98	1.57	1.57	2.11	0.33

Dimensions

Cavity	Ports	A	B	C	E	F	G	H	I	L	M	N	Z	
SAE 16/3	G 3/4	mm	90	100	50	10	70	90	10	25,1	45	45	53,5	10,5
		in	3.54	3.94	1.97	0.39	2.75	3.54	0.39	0.99	1.77	1.77	2.11	0.41
	SAE12	mm	90	105	50	10	70	95	10	25,1	45	45	53,5	10,5
		in	3.54	4.13	1.97	0.39	2.75	3.74	0.39	0.99	1.77	1.77	2.11	0.41
	SAE16	mm	90	105	50	10	70	95	10	25,1	45	45	53,5	10,5
		in	3.54	4.13	1.97	0.39	2.75	3.74	0.39	0.99	1.77	1.77	2.11	0.41

Order code

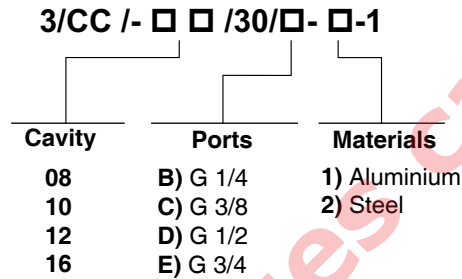

see SAE cartridges Catalogue

2, 3 and 4 way Valves Bodies

4 WAY BODIES

Dimensions

Material	Max pressure	
	bar	psi
Aluminium	210	3050
Steel	350	5100

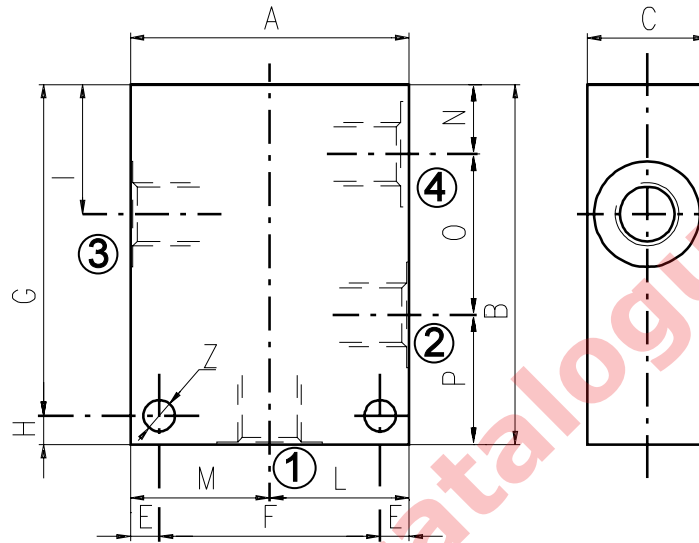

Cavity	Ports	A	B	C	E	F	G	H	I	L	M	N	O	P	Z	
SAE 8/4	G 1/4	mm	60	75	30	7	46	63	12	29,1	30	30	14,8	29,1	31,1	6,5
		in	2.36	2.95	1.18	0.27	1.81	2.48	0.47	1.14	1.18	1.18	0.58	1.14	1.22	0.25
	SAE6	mm	60	75	30	7	46	63	12	29,1	30	30	14,8	29,1	31,1	6,5
		in	2.36	2.95	1.18	0.27	1.81	2.48	0.47	1.14	1.18	1.18	0.58	1.14	1.22	0.25
SAE 10/4	G 3/8	mm	60	85	35	6	48	79	6	34,5	30	30	18,8	31,7	34,5	7
		in	2.36	3.35	1.38	0.24	1.89	3.11	0.24	1.36	1.18	1.18	0.74	1.25	1.36	0.27
	G 1/2	mm	70	85	35	6	58	79	6	34,5	35	35	18,8	31,7	34,5	7
		in	2.75	3.35	1.38	0.24	2.28	3.11	0.24	1.36	1.38	1.38	0.74	1.25	1.36	0.27
	SAE6	mm	60	85	35	6	48	79	6	34,5	30	30	18,8	31,7	34,5	7
		in	2.36	3.35	1.38	0.24	1.89	3.11	0.24	1.36	1.18	1.18	0.74	1.25	1.36	0.27
SAE8	mm	70	85	35	6	58	79	6	34,5	35	35	18,8	31,7	34,5	7	
	in	2.75	3.35	1.38	0.24	2.28	3.11	0.24	1.36	1.38	1.38	0.74	1.25	1.36	0.27	
SAE 12/4	G 1/2	mm	80	115	40	8	64	107	8	44	40	40	22	44,5	48,5	8,5
		in	3.15	4.53	1.57	0.31	2.52	4.21	0.31	1.73	1.57	1.57	0.87	1.75	1.9	0.33
	SAE10	mm	80	115	40	8	64	107	8	44	40	40	22	44,5	48,5	8,5
		in	3.15	4.53	1.57	0.31	2.52	4.21	0.31	1.73	1.57	1.57	0.87	1.75	1.9	0.33
SAE 16/4	G 3/4	mm	100	130	50	10	80	120	10	53,5	50	50	25,1	56,9	48	10,5
		in	3.94	5.12	1.97	0.39	3.15	4.72	0.39	2.11	1.97	1.97	0.99	2.24	1.89	0.41

Order code

3/CC /- □ □ /40/□- □-1

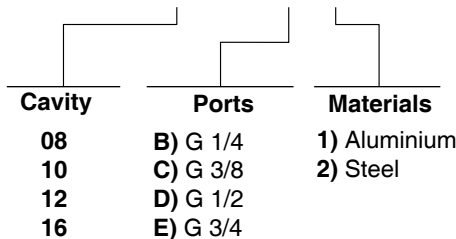

How to order valves with body

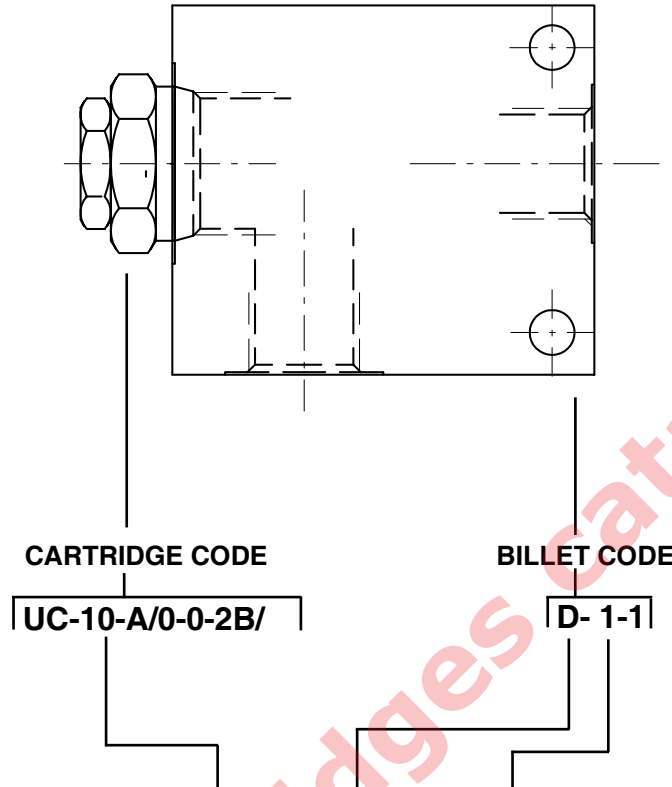

CavitY	Ports	Materials
08	B) G 1/4	1) Aluminium 2) Steel
10	C) G 3/8	
12	D) G 1/2	
16	E) G 3/4	
	F) G 1	
	J) SAE 6	
	K) SAE 8	
	L) SAE 10	
	M) SAE 12	
	N) SAE 16	

Dimensions

VARIATION "A": the dimensions with "*" are related to the variation "A". Features of variation "A" are required only if noted on specific product catalogue page.

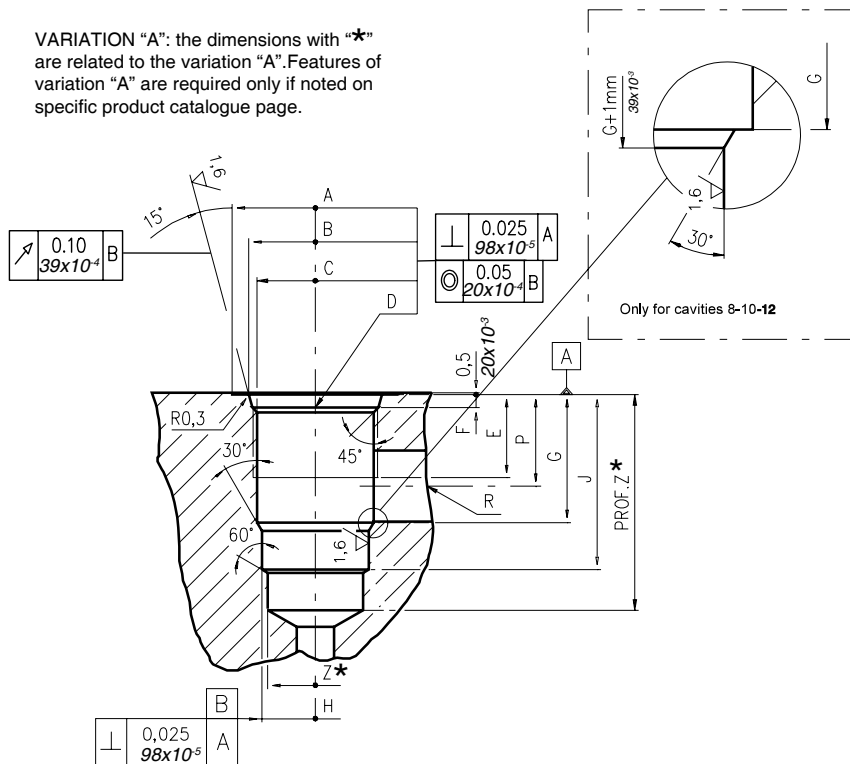

Cavity	A	B ±0,05	C ±0,05	D	E	F	G	H ±0,02	J	K ±0,02	L	M ±0,02	N	P	R øMAX	S	T øMAX	U	V øMAX	X øMAX	Z*	Prof.Z MIN*	
																							mm
08/2	mm	27	20,66	17,42	3/4 -16 UNF	12,50	2,50	18,20	12,72	29,50	-	-	-	-	14,00	8,00	-	-	-	-	-	12,00	39
	in	1.06	0.81	0.68		0.49	0.10	0.72	0.50	1.16	-	-	-	-	0.55	0.31	-	-	-	-	-	0.47	1.53
10/2	mm	30	24,00	20,62	7/8 -14 UNF	16,00	2,80	24,00	15,90	33,50	-	-	-	-	18,30	11,00	-	-	-	-	-	14,50	40
	in	1.18	0.94	0.81		0.63	0.11	0.94	0.62	1.32	-	-	-	-	0.72	0.43	-	-	-	-	-	0.57	1.57
12/2	mm	38	29,23	24,73	1 1/16 -12 UNF	19,00	3,50	34,15	22,25	46,80	-	-	-	-	24,50	19,00	-	-	-	-	-	21,50	60
	in	1.50	1.15	0.97		0.75	0.14	1.34	0.87	1.84	-	-	-	-	0.96	0.75	-	-	-	-	-	0.85	2.36
16/2	mm	45	35,60	31,34	1 5/16 -12 UNF	22,00	3,50	34,00	28,62	47,00	-	-	-	-	24,50	19,00	-	-	-	-	-	25,50	70
	in	1.77	1.40	1.23		0.87	0.14	1.34	1.13	1.85	-	-	-	-	0.96	0.75	-	-	-	-	-	1.00	2.75

Rougher tool

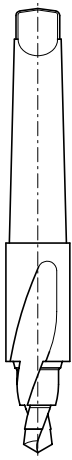

Cavity	Code number
08/2	3UT00053190
10/2	3UT00056610
12/2	3UT00054090
16/2	3UT00054510

Finisher tool



Cavity	Code number
08/2	3UT06A1270N
10/2	3UT00054580
12/2	3UT00054670
16/2	3UT00054520

Tap

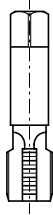

Cavity	Code number
08/2	3UT03416UNF
10/2	3UT07814UNF
12/2	3UT0111612UN
16/2	3UT0151612UN

Cavity plugs

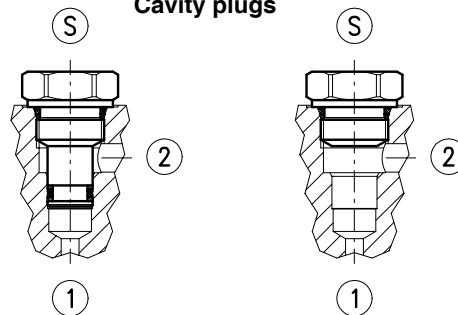

Cavity	Code number	①	②	Ⓢ
08/2	3XTP3533700	X	X	X
	3XTP1531900	0	0	X
10/2	3XTP3544200	X	X	X
	3XTP1542300	0	0	X
12/2	3XTP3555400	X	X	X
	3XTP1552900	0	0	X
16/2	3XTP3575500	X	X	X
	3XTP1572900	0	0	X

X=Closed 0=Open

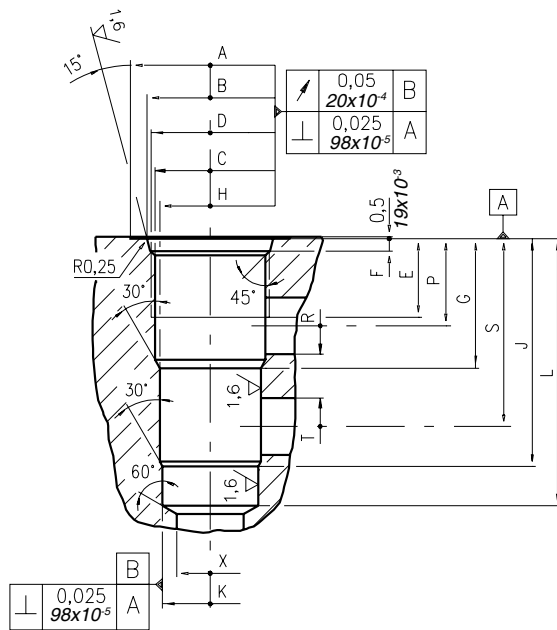

\	A	B ±0,05	C ±0,05	D	E	F	G	H ±0,02	J	K ±0,02	L	M ±0,02	N	P	R øMAX	S	T øMAX	U	V øMAX	X øMAX	Z øMIN	Prof. Z MIN	
08/3	mm	27	20,66	17,42	3/4 -16 UNF	12,50	2,50	19,10	15,90	33,30	14,30	43,30	-	-	14,30	5,50	28,60	5,50	-	-	12,50	-	-
	in	1.06	0.81	0.68		0.49	0.10	0.75	0.62	1.31	0.56	1.70	-	-	0.56	0.22	1.12	0.22	-	-	0.49	-	-
10/3	mm	30	24,00	20,62	7/8 -14 UNF	16,00	2,80	23,10	17,50	39,60	15,90	47,60	-	-	18,30	6,50	34,00	6,50	-	-	14,00	-	-
	in	1.18	0.94	0.81		0.63	0.11	0.94	0.69	1.56	0.62	1.87	-	-	0.72	0.25	1.34	0.25	-	-	0.55	-	-
12/3	mm	38	29,23	24,73	1 1/16 -12 UNF	19,00	3,56	36,60	23,82	63,50	22,25	75,40	-	-	24,50	16,00	53,00	16,00	-	-	19,00	-	-
	in	1.50	1.15	0.97		0.75	0.14	1.44	0.94	2.5	0.88	2.97	-	-	0.96	0.63	2.09	0.63	-	-	0.75	-	-
16/3	mm	45	35,60	31,34	1 5/16 -12 UNF	22,00	3,50	36,50	28,62	64,30	27,02	75,30	-	-	24,50	16,00	53,00	16,00	-	-	19,00	-	-
	in	1.77	1.40	1.23		0.87	0.14	1.44	1.13	2.53	1.06	2.96	-	-	0.96	0.63	2.09	0.63	-	-	0.75	-	-

Rougher tool

Finisher tool

Cavity plugs

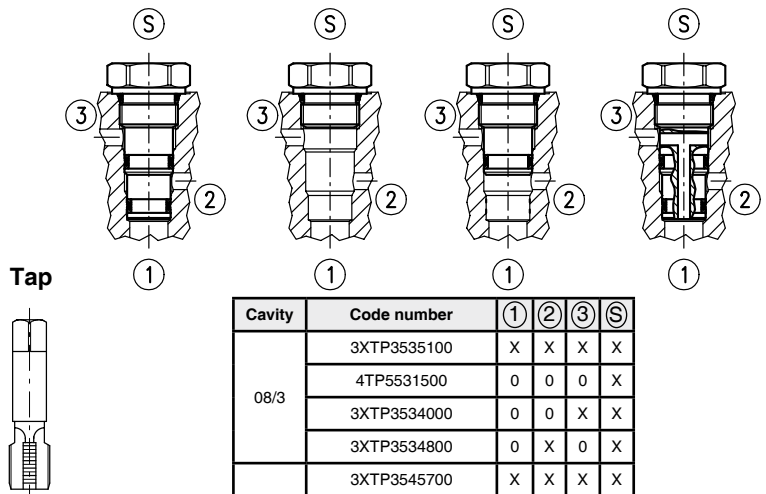
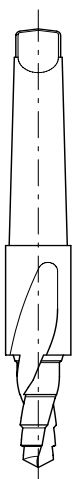

Tap

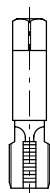

Cavity	Code number
08/3	3UT00052190
10/3	3UT00054170
12/3	3UT00054290
16/3	3UT00054470

Cavity	Code number
08/3	3UT00052740
10/3	3UT00054180
12/3	3UT00054300
16/3	3UT00054480

Cavity	Code number
08/3	3UT03416UNF
10/3	3UT07814UNF
12/3	3UT0111612UN
16/3	3UT0151612UN

Cavity	Code number	①	②	③	④
08/3	3XTP3535100	X	X	X	X
	4TP5531500	0	0	0	X
	3XTP3534000	0	0	X	X
	3XTP3534800	0	X	0	X
10/3	3XTP3545700	X	X	X	X
	3XTP1542300	0	0	0	X
	3XTP3545701	0	X	0	X
12/3	3XTP3558200	X	X	X	X
	3XTP1552900	0	0	0	X
	3XTP35558201	0	X	0	X
16/3	3XTP3578400	X	X	X	X
	3XTP1572900	0	0	0	X

X=Closed 0=Open

Dimensions

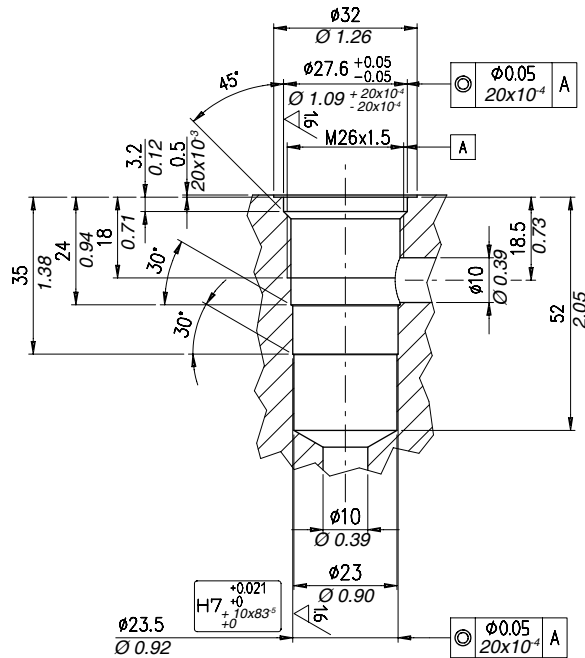

Rougher tool
Code 3UT00050140

Finisher tool
Code 3UT00055020

Tap
Code 3UT08A26F150

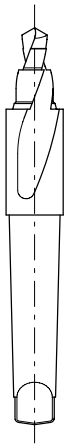

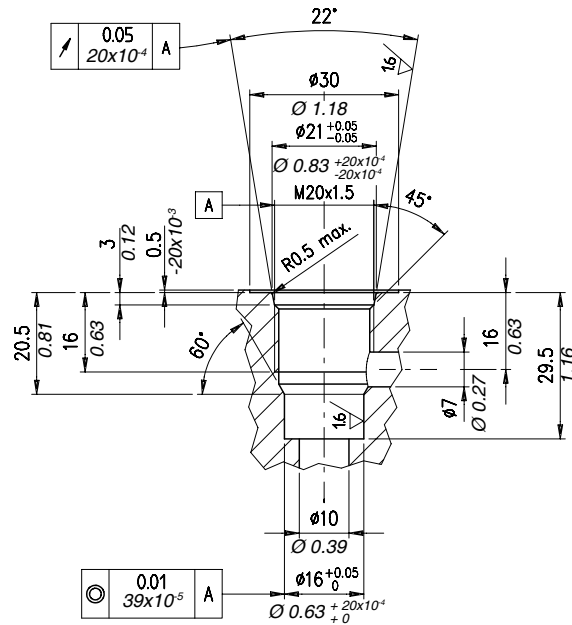

Rougher tool
Cod.3UT00050800

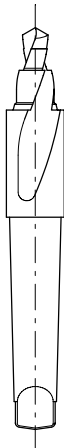

Finisher tool
Cod.3UT06A1600N



Tap
Cod.3UT08A20F150

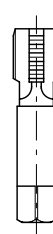

Dimensions

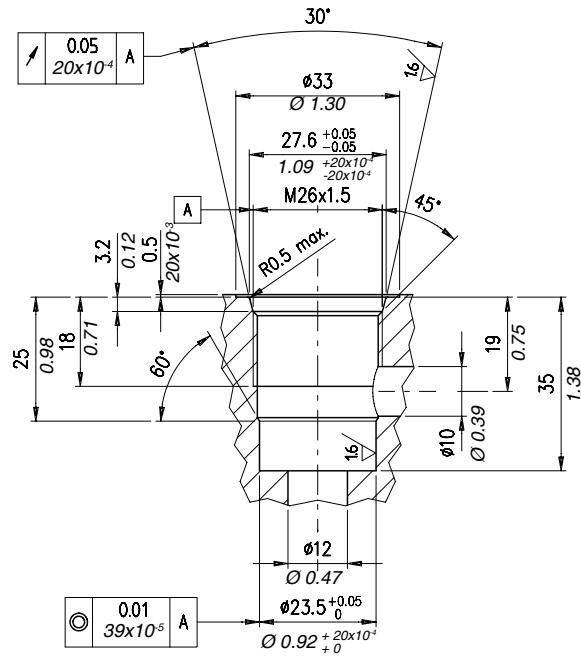

Rougher tool
Code 3UT00050140

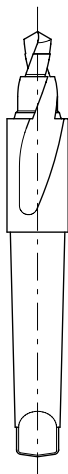

Finisher tool
Code 3UT00055020

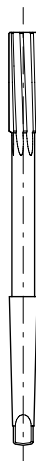

Tap
Code 3UT08A26F150

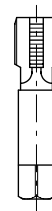

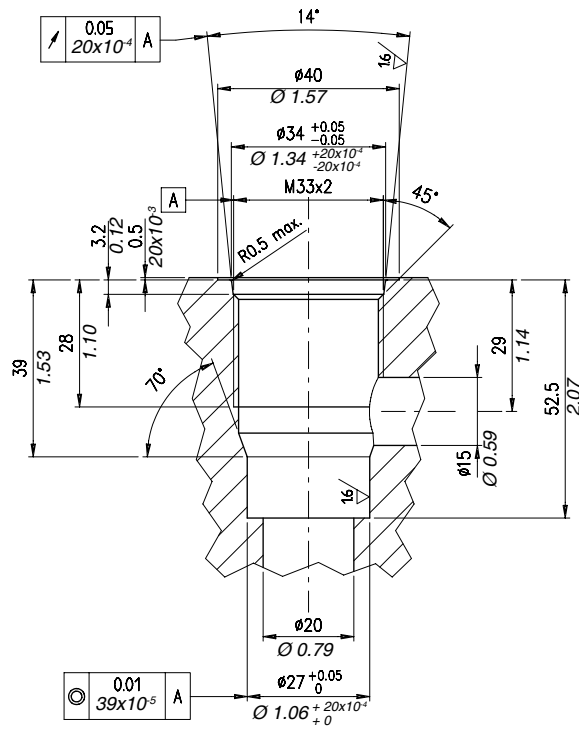

Rougher tool
Code 3UT00050460

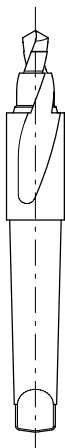

Finisher tool
Code 3UT06A2700N



Tap
Code 3UT08A33F200



Dimensions

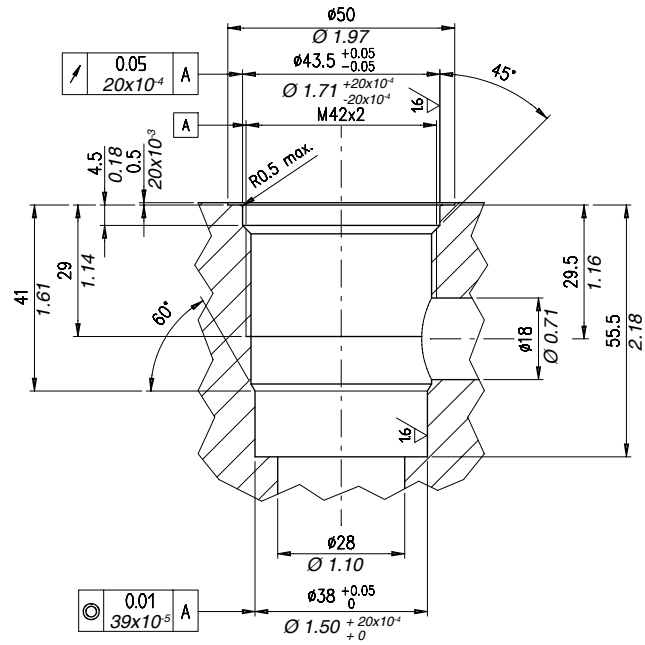

Rougher tool

Code 3UT00050780

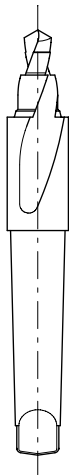

Finisher

Code 3UT06A3800N



Cavity plugs

Code 3UT08A42F200

