

## CARATTERISTICHE

Luce nominale  
 Portata min/max  
 Pressione max. di picco  
 Pressione max. di taratura  
 Rapporto di pilotaggio standard  
 Temperatura ambiente  
 Temperatura olio  
 Filtraggio consigliato

**DN 8/10**  
**1/60 l/min - 0.26/15 GPM**  
**350 bar - 5075 PSI**  
**350 bar - 5075 PSI**  
**4.25: 1**  
**-30°C + 50°C**  
**-30°C + 80°C**  
**30 micron**

## PERFORMANCE

Rated size  
 Min/max flow-rate  
 Max peak pressure  
 Max setting pressure  
 Standard pilot ratio  
 Room temperature  
 Oil temperature  
 Recommended filtration

### NOTE:

La taratura deve essere **1.3** volte maggiore della pressione indotta dal carico.

Valve should be set at **1.3** times load induced pressure.

### ESEMPIO/EXAMPLE:

Pressione di lavoro max:

Max working pressure:

**350 bar / 1.3 = 270 bar**

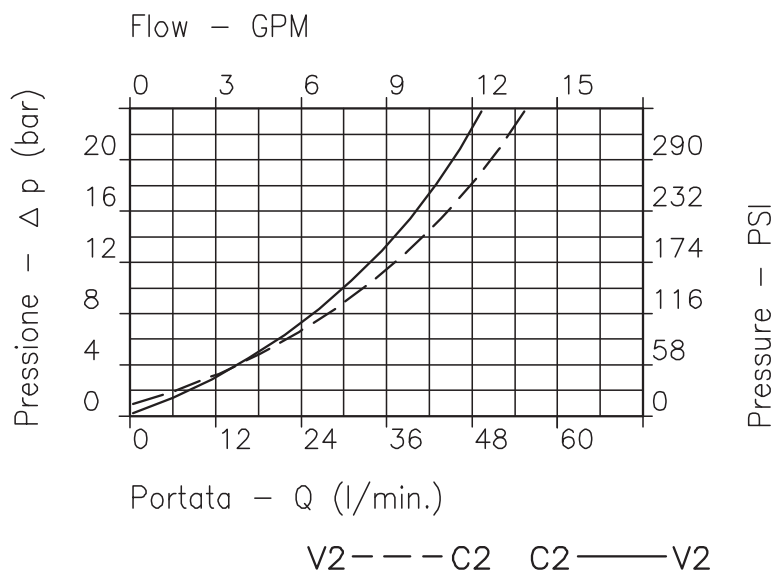

Viscosità olio 46 cSt a 50°C  
 Oil viscosity 46 cSt at 50°C

**VALVOLA BILANCIAMENTO, BLOCCO E CONTROLLO MOVIMENTO PER CENTRO CHIUSO, A DOPPIO EFFETTO CON COLLETTORE FLANGIATO**  
**DOUBLE COUNTERBALANCE VALVE FOR CLOSED CENTRE SPOOL WITH FLANGEABLE BODY**

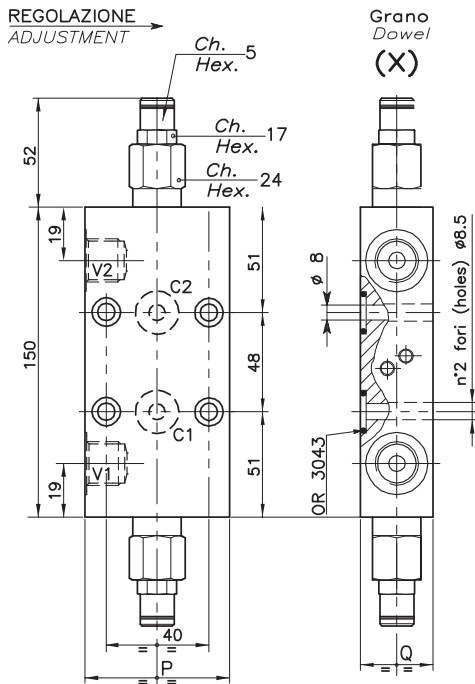

**ESEMPIO TIPICO DI CIRCUITO**  
**TYPICAL CIRCUIT EXAMPLE**

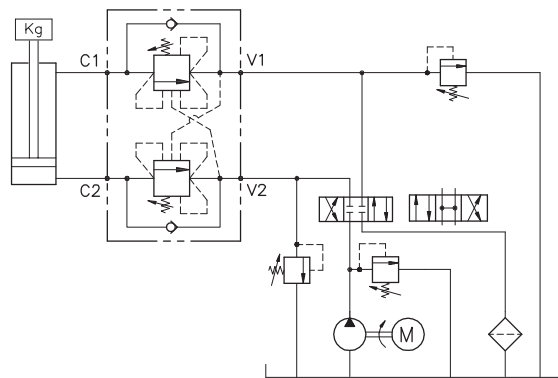

**DIMENSIONI**  
**DIMENSIONS**

Campo taratura Setting range		P	Q	Attacchi Port size V1-C1 GAS (BSPP)	Luce nominale Rated size DN	Portata max Max flow-rate l/min - GPM
121	120	55	29.5	3/8"	8	40-10
123	122	65	34.5	1/2"	10	60-15

**CODICE DI ORDINAZIONE**  
**HOW TO ORDER**

001 . 121 . 0 X 0 . A

Campo taratura / Setting range				Rapporto di pilotaggio Pilot ratios	Regolazione Adjustment	Collettore Body
121	120			O   4.25: 1	X   Grano - Dowel	A   Acciaio zincato Zinc plated steel
123	122					
Campo taratura 30÷220 bar (molla colore verde) Setting range 30÷220 bar (green spring)		Campo taratura 60÷350 bar (molla colore rosso) Setting range 60÷350 bar (red spring)				
Taratura standard (Q=5 l/1')	Incr. press. - bar giro/vite	Taratura standard (Q=5 l/1')	Incr. press. - bar giro/vite			
Std. bar setting (Q=5 l/1')	Pressure rise - turn of screw	Std. bar setting (Q=5 l/1')	Pressure rise - turn of screw			
<b>180 bar</b>	<b>(60)</b>	<b>250 bar</b>	<b>(140)</b>			