

AP250HP Gear Pumps

Single and multiple cast iron gear pumps



Contents

Page

1	General information	3
1.1	External gear pumps components and construction / benefits	4
1.2	Technical data	5
1.3	Pressure	6
1.4	Suction	6
1.5	General precaution	6
1.6	Identifying the rotation direction	7
1.7	Formulas to determinate main gear pump operate parameters	8
2	Overview standard pump configurations	9
2.1	Standard components configuration	9
3	AP250HP Single pump customised versions	14
3.1	Single pump customised versions order example	15
3.2	Single pump dimensions	16
3.3	Shaft end code	17
3.4	Front cover/mounting flange	18
4	Multiple gear pumps	23
4.1	Multiple gear pumps: AP250HP+AP250HP standard versions	23
4.2	Multiple gear pumps: AP250HP+AP250HP+AP250HP standard versions	26
4.3	Multiple gear pumps: AP250HP+AP212 standard versions	29
4.4	Multiple gear pumps: AP250HP+AP212+AP212 standard versions	33
4.5	Multiple gear pumps: AP250HP+AP250HP+AP212 standard versions	37
5	Circuits/valves option	41
5.1	Load sensing circuits	41
5.2	Max pressure relief valve circuits	42
6	Product identification plate	43
7	Application form	44

1 General information

The product range of Bucher Hydraulics SpA includes single pumps 05-100-212-212HP-250HP-300-312HP (corresponding with the common group denominations: 05-1-2-2.5-3) and several combinations of double pumps, triple pumps, and so on, that can be assembled together according to versions of displacement, flanging, and auxiliary valves .

Bucher Hydraulics SpA has supplied a wide range of external gear pumps and motors to industrial and mobile applications since many years.

Bucher's external gear pumps are widely used in modern hydraulic system to obtain high performances, long life service and low purchase and maintenance costs.

Now, Bucher is introducing a new Gear Pumps family, AP250HP (group 2.5), specifically developed for wheel loaders, excavators and telehandlers applications.

Bucher designed this new pump AP250HP with support bearings mounted in the cast iron body and covers. Tandem and triple pumps are also available with direct connections between the shafts.

AP250HP is the result of a focused design, studied also with the aid of a software internally developed and used for the calculations of the most important mechanical parameters of the gears and to optimize all the performances with a consequent noise and vibration reduction.

Bucher Hydraulics has so achieved this state of the art by constantly improving its design, control and manufacturing techniques aligned with the latest technological developments, while simultaneously enhancing its Quality System ensuring that every single product offers the same high standards.

Main applications and benefits



- Long life expectancy
- High efficiencies
- Noise & vibration reduction
- Strong interface
- Shaft load reduction
- AP250HP flange interface
- High pressure limits
- Reduced number of components
- Reduced overall dimension
- Direct and stronger connections between shafts (tandem/Triple pumps)

The AP250HP cast iron gear pump mix the best part of AP212 and AP300 frame sizes improving power density due to wide range of displacements from 15 to 54 cm³/rev.

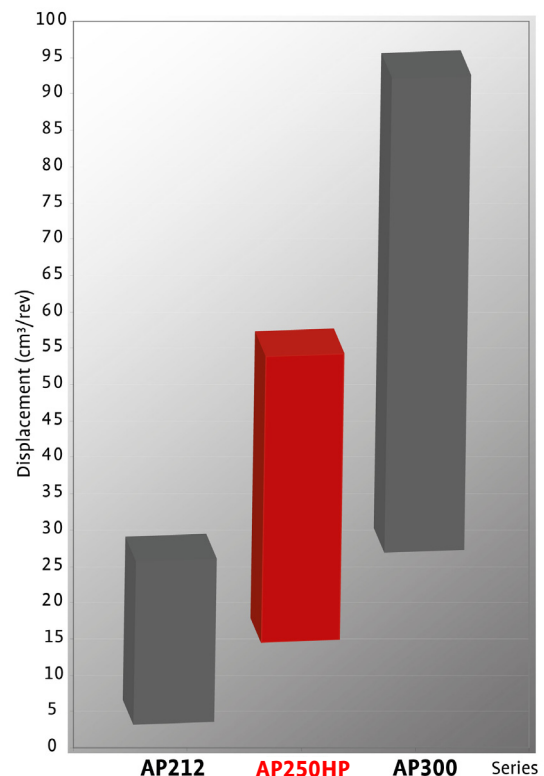

1.1 External gear pumps components and construction / benefits

A
Cast iron front cover: the standard front-cover design can be fitted to two different pump interfaces.

B
Cast iron main pump body: wide range of displacements obtainable with two different basic bodies. Pump centre-section and back cover integrated in only one body. Rear ports on request.

C
HNBR seal material instead of NBR.

D
Double HNBR shaft seals.

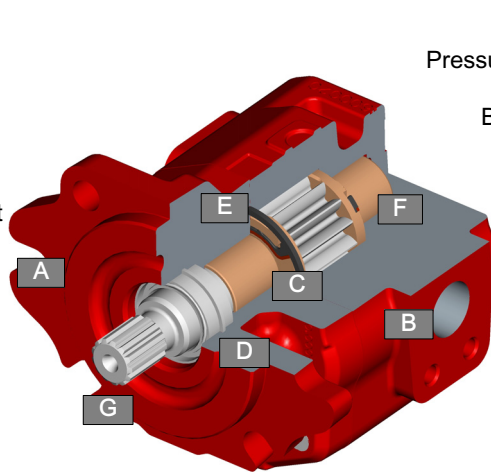

E
Pressure-balance plate manufactured in bronze instead of aluminium. Balancing area and intermediate notches optimised.

F
Large-diameter bearings, fitted both in front cover and body.

G
Large number of teeth, tooth profile optimised, larger shaft diameter.

BENEFITS



A B Flexibility/smaller number of components

A B D Reduced risk of external leakage

A B E High efficiencies/pressure limits

A B E Long life expectancy

C D Wider temperature range

E G Lower pressure ripple

E G Noise/vibration reduction

E F G Higher load capacity and transmissible torque

E F G Low friction and high mechanical efficiency

E F G Higher max. pressure limit

The front mounting flange and the body/backcover are made of high-strength cast iron to give thermal stability, resistance to contamination and the strength necessary for persistently high levels of performance and life, needed in demanding heavy duty applications. Body/back cover integrated, bigger shaft diameter, bigger bearing dimension and bronze trust plate have been optimized to provide

heavy duty, high pressure limits, high efficiencies and long life expectancy.

Noise and vibration reduction due to the high number of teeth.

The bearings are located in the front mounting flange, in the body/back cover and, for multiple pumps, in the intermediate cover.

1.2 Technical data

Features		
Displacements	15.2 - 54 cm ³ /rev	
Maximum continuous pressure	300 bar (depending on displacement)	
Fluid temperature range	-15 / +80 °C (Extreme condition temperature range: -25 +110 °C)*	
Recommended fluids	hydraulic mineral oil-based	
Viscosity range:	Recommended Permitted (not continuous) Permitted for starting	20-120 mm ² /s (cSt) up to 700 mm ² /s (cSt) 2000 mm ² /s (cSt)
Contamination class:	working pressure > 210 bar working pressure < 210 bar	19/17/14 ISO 4406 20/18/15 ISO 4406
		8 NAS1638 9 NAS 1638
Standard seals material	HNBR standard	

* Extreme working temperature limits values can not be combined

Type	Displacement		Pressure				Min speed rpm	Max speed** rpm
	cm ³ /rev	Cu.In.P.R.	P1		P3			
			bar	P.S.I.	bar	P.S.I.		
15	15.2	.928	300	4300	320	4600	500	3500
19	19.1	1.166	300	4300	320	4600	500	3500
23	23	1.403	300	4300	320	4600	500	3500
26	26.4	1.611	300	4300	320	4600	500	3500
29	29.3	1.788	300	4300	320	4600	500	3500
33	33.2	2.026	300	4300	320	4600	500	3500
36	36.1	2.203	300	4300	320	4600	500	3500
40	40.5	2.471	275	4000	290	4200	500	3500
45	45.3	2.764	245	3500	260	3700	500	3500
50	50.2	3.063	220	3200	235	3400	500	3000
54	54	3.295	205	3000	220	3200	500	3000

** : The max admitted speed is referred to single pump/single inlet configuration. In case of multiple pumps with common suction line, a speed reduction must be considered.



IMPORTANT!: The pressure values are referred to unidirectional pumps, single versions only.

Please consult Bucher Hydraulics if even one of the operating limits indicated in the table (temperature, pressure, rpm) is exceeded, as well as in the case of two or more maximum values at the same time, or for applications with particularly heavy-duty cycles

1.3 Pressure

Pressure levels:

P1 = continuous pressure

P3 = peak pressure

The recommended oil speed in the pressure pipes is:

$$v = 2 \text{ to } 5 \text{ m/s}$$

1.4 Suction

The absolute suction pressure must be $P_{in} \geq 0.75 \text{ bar}$ (11 PSI); therefore, the following must be avoided:

- large height differences between pump and tank
- long stretches of piping
- special features such as:
 - bends
 - reductions in diameter
 - quick couplings
 - etc.

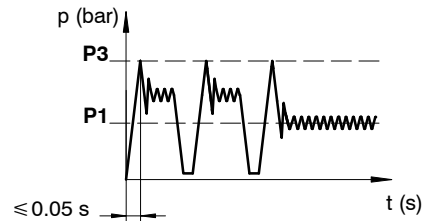
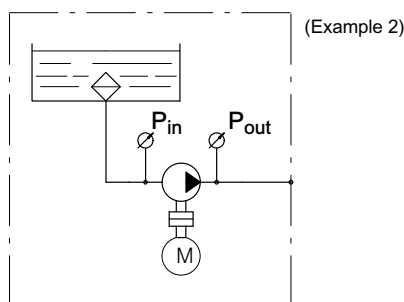
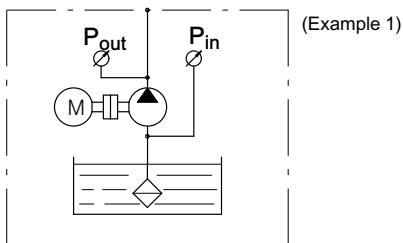

It is also advisable to choose a filter of a suitable size to minimise any pressure drop and to take measures to prevent gradual clogging over time.

1.5 General precaution

In addition to the recommendations regarding fluids, filtration, coupling, etc., we suggest the following:

- Always check the rotation direction of the pump's drive shaft; it must be compatible with the rotation direction of the pump itself.
- Be particularly careful in cleaning and make sure, when connecting the suction and pressure piping, that no chips, rag threads, teflon tape, etc. get into the pump circulation system.
- Check the tightness of the suction and pressure fittings, the correct positioning of the O-Ring, and make sure there is no dirt between the flange and the pump body.
- The first pump start-up can be facilitated by manually filling the suction piping and the pump itself with oil. To facilitate air bleeding, start the pump with the circuit not pressurised.

- To ensure the best heat distribution inside the tank, make sure the return pipe is not too close to the pump's suction piping. The pipings themselves should be below oil tank level to prevent the formation of foam.
- Do not subject the pumps to operating conditions different from those indicated on section 1.2 ; for extreme operations, always contact our Sales Department.
- In the event of pump painting, do not use solvents or paints that are incompatible with the material of the seals. Do not bake paint with excessively high temperatures. Do not paint over the product identification plate.

1.5.1 Hydraulic fluid

The main function of the fluid used in hydraulic systems is to transfer energy but it performs also other important functions: protect the components from corrosion, lubricate the pump moving parts, remove particles and heat from the system.

In order to ensure proper operation and long life of the system it is important to choose the correct hydraulic fluid with proper additives.

Bucher Hydraulics recommends to use a mineral based oil responding to ISO 6743/4 requirements, only.

The system should be operated only with hydraulic oil containing anti-foaming and antioxidant additives. Before using other types of fluid, please contact our Sales Dept, since they can cause serious damage to the directional valve components and jeopardize the correct function of the system.

Never use fluids different from those indicated in section 1.2 and do not use fluids incompatible with the pump seals (i.e. HNBR)

1.5.2 Filtration

In order to ensure proper operation and long life of the pump components it is extremely important to provide a proper and effective filtration of the hydraulic fluid.

It is advisable to follow filter manufacturers instruction and recommendations.

The fineness of the filter should be selected in order to guarantee that a contamination levels indicated on section 1.2. When the high reliability of the system is an important requirement, a pressure filter must be used. In these cases it is also advisable to use a pressure filter with by-pass and indicator.

The size of the return filters must suit the maximum return

flow whereas the size of the pressure filters must suit the maximum pump flow.

It is advisable to fit filters with pressure gauge or dirt indicator in order to make it possible to verify the filter condition. Particular attention has to be paid to the cleaning of the machine hydraulic circuit and its components before the first run-in, since the presence of foreign materials could cause damages even if a proper filtration is provided.

In order to obtain the best performance of the system we recommend to strictly follow the conditions advised here above, failing which warranty shall be void.

1.5.3 Directives and standards

Atex



Attention: The equipment and protective systems of this catalogue ARE NOT intended for use in potentially explosive atmospheres that is to say where there is an explosive atmosphere. Ref: Directive 99/92/EC and Directive 2014/34/UE.

- ISO 9001: 2008 / ISO 14001:2004

Bucher Hydraulics S.p.A. is certified for research, development and production of directional control valves, gear pumps and motors, power units, electro pumps, cart-ridge valves and integrated manifolds for hydraulic applications.

1.6 Identifying the rotation direction

The rotation direction of a gear pump is identified by looking at the pump from the front and with the drive gear turned upwards (see figures below).

Pumps with clockwise rotation (D) have a drive gear which turns clockwise, with the suction port on the left and the pressure port on the right.

Pumps with counterclockwise rotation (S) have a drive gear which turns counterclockwise, with the suction port on the

right and the pressure port on the left. The figure also shows the pressure flow inside the pumps as the oil is transferred from the suction port to the pressure port.

Pumps with a unidirectional rotation (D or S) have the denomination AP.

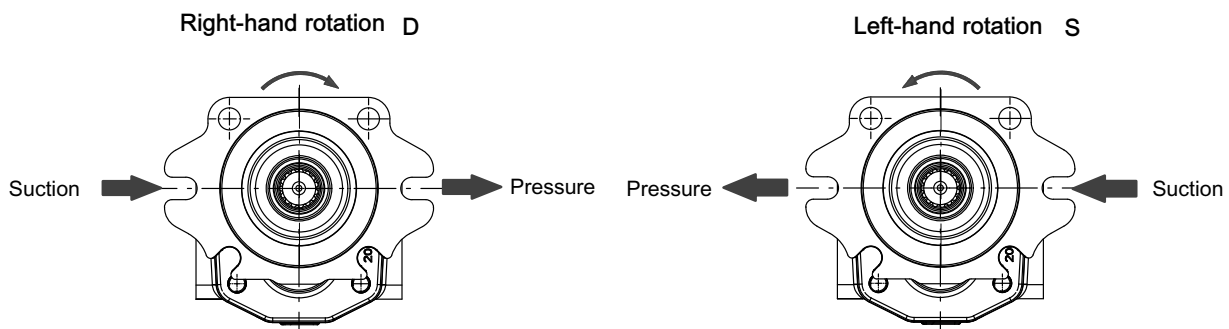

1.7 Formulas to determinate main gear pump operate parameters

The following parameters are defined:

V_c = (cm³/rev) pump displacement;

n = (rev/min) no. of rpms of the drive shaft;

Q = (l/min) flow rate;

p = (bar) operating pressure;

T = (Nm) drive torque;

N = (kW) Absorbed power;

η_v = (%) volumetric efficiency;

η_m = (%) mechanical efficiency;

η_t = (%) total efficiency

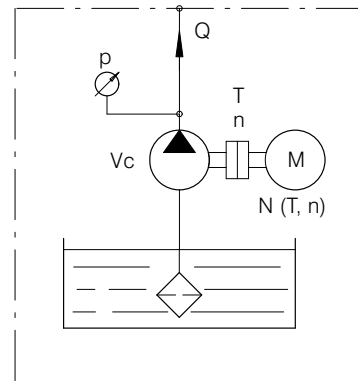

$$Q = \frac{V_c \cdot n}{100000} \cdot \eta_v \quad T = 1.59 \cdot \frac{p \cdot V_c}{\eta_m} \quad N = \frac{Q \cdot p}{6 \cdot \eta_t}$$

Example

AP250HP/15 $V_c = 15.2 \text{ cm}^3/\text{r}$ $n = 1500 \text{ r/min}$ $p = 200 \text{ bar}$ $\eta_v = 94\%$ $\eta_m = 90\%$ $\eta_t = 84.6\%$

$$Q = \frac{15.2 \cdot 1500}{100000} \cdot 94 = 21.43 \text{ l/min.}$$

$$T = 1.59 \cdot \frac{200 \cdot 15.2}{90} = 53.7 \text{ Nm}$$

$$N = \frac{21.43 \cdot 200}{6 \cdot 84.6} = 8.44 \text{ kW}$$

2 Overview standard pump configurations

This pumps configuration are considered as "standard".

13 teeth	S38B2P	S38B2S	S38B8G	S38B8S
15 teeth	S58B2P	S58B2S	S58B8G	S58B8S

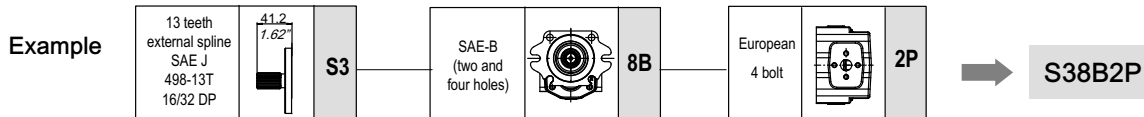

In the next pages, front, body/rear cover, and seals materials are listed for each pump series. For ordering purposes, it is enough to outline the complete pump description (for example: AP250HP/15 2P8BS3).

In case of a different configuration request (or a combination of different features, such as port threads, front flange materials, etc.), the description configurator shown in section 3.1 can be easily used.

2.1 Standard components configuration

Drive shaft			Cast iron flange			Cast iron body/back cover Port type		
13 teeth external spline SAE J 498-13T 16/32 DP $T_{max}=270\text{ Nm}$		S3	SAE-B (two and four holes)		8B	European 4 bolts flanged		2P
15 teeth external spline SAE J 498-15T 16/32 DP $T_{max}=460\text{ Nm}$		S5				SAE FLANGED PORTS J518 (3000 PSI series)		2S
						BSP Ports		8G
						SAE threaded ports UNF		8S

Serie	page	Serie	page	Serie	page	Serie	page
S38B2P-S58B2P		S38B2S-S58B2S		S38B8G-S58B8G		S38B8S-S58B8S	
	10		11		12		13

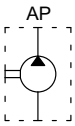

S38B2P
S58B2P

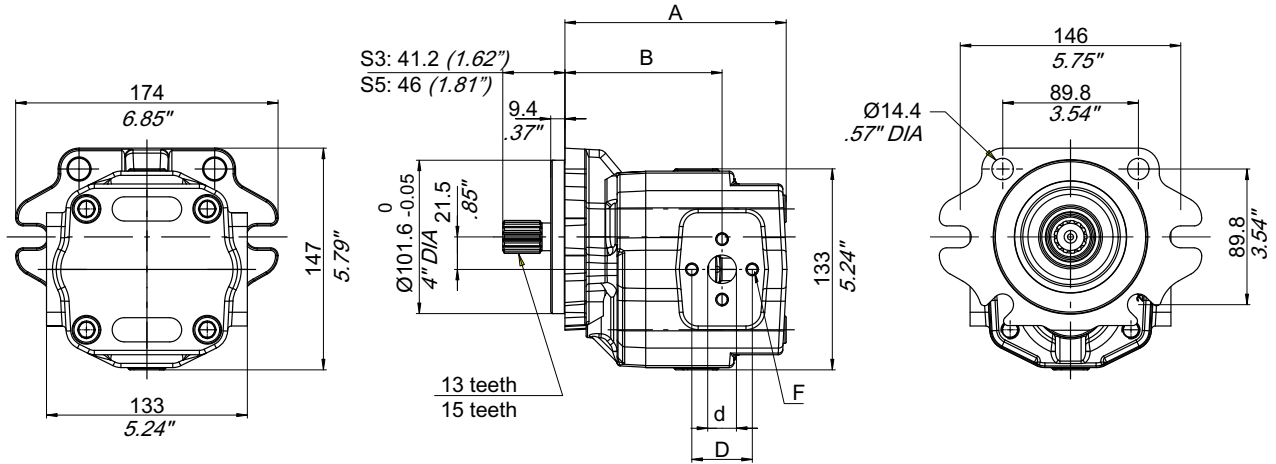
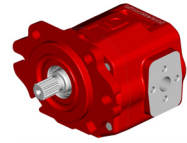

Type	A		B		Suction			Pressure						
	mm	inches	mm	inches	d	D	F	d	D	F				
					mm	inches	mm	inches	mm	inches	mm	inches	mm	
15	128	5.04	85.5	3.37	19	.75	40	1.57	M8x1.25	19	.75	40	1.57	M8x1.25
19	132	5.20	89.5	3.52										
23	136	5.35	93.5	3.68										
26	139.5	5.49	97	3.82										
29	142.5	5.61	100	3.94										
33	146.5	5.77	104	4.09										
36	149.5	5.89	102	4.02	25	.98	51	2.01	M10x1.5	19	.75	40	1.57	M8x1.25
40	154	6.06	106.5	4.19										
45	159	6.25	111.5	4.39										
50	164	6.46	116.5	4.59										
54	168	6.61	120.5	4.74										

Pump description example:

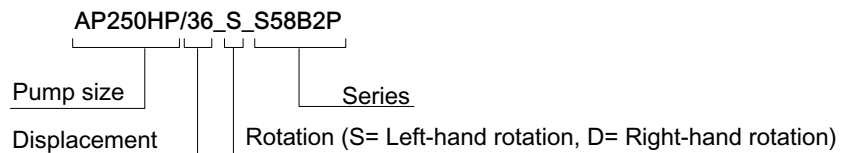

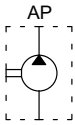

S38B2S
S58B2S

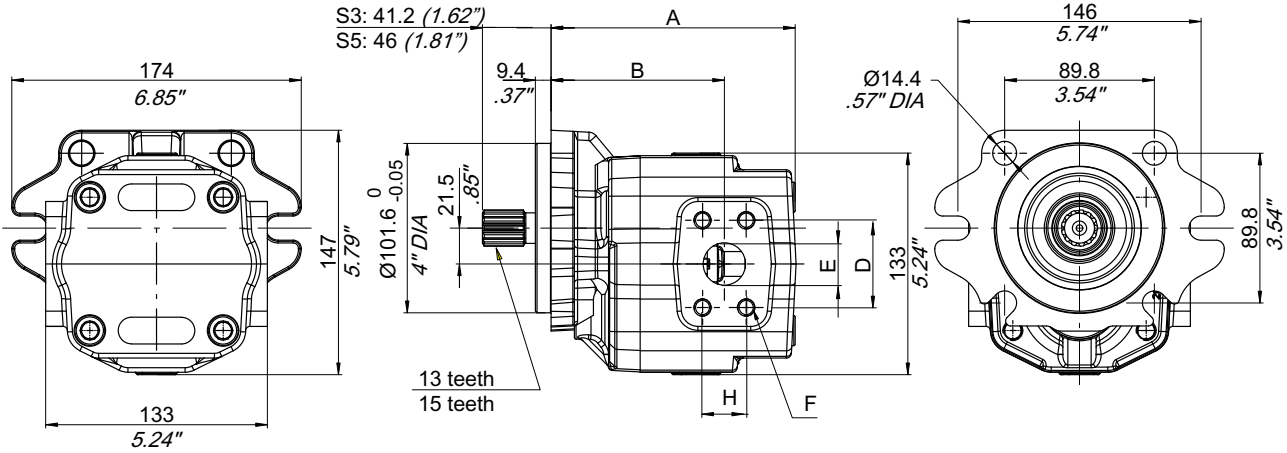
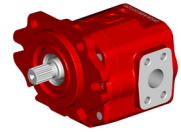

Type	A		B		Suction						Pressure								
	mm	inches	mm	inches	H		D		E		F	H		D		E		F	
					mm	inch.	mm	inch.	mm	inch.	mm	mm	mm	inch.	mm	inch.	mm	mm	
15	128	5.04	85.5	3.37															
19	132	5.20	89.5	3.52	26.19	1.03	52.37	2.06	25.4	1		22.23	.88	47.63	1.88	19	.75		
23	136	5.35	93.5	3.68															
26	139.5	5.49	97	3.82															
29	142.5	5.61	100	3.94															
33	146.5	5.77	104	4.09	30.17	1.19	58.72	2.31	31.8	1.25									M10x 1.5
36	149.5	5.89	102	4.02															
40	154	6.06	106.5	4.19								26.19	1.03	52.37	2.06	25.4	1		
45	159	6.25	111.5	4.39															
50	164	6.46	116.5	4.59	35.71	1.14	69.85	2.75	38.1	1.5									M12x 1.75
54	168	6.61	120.5	4.74															

Pump description example:

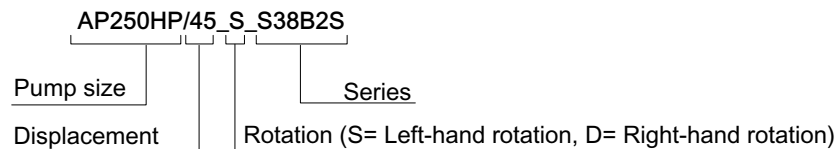

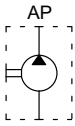

S38B8G
S58B8G

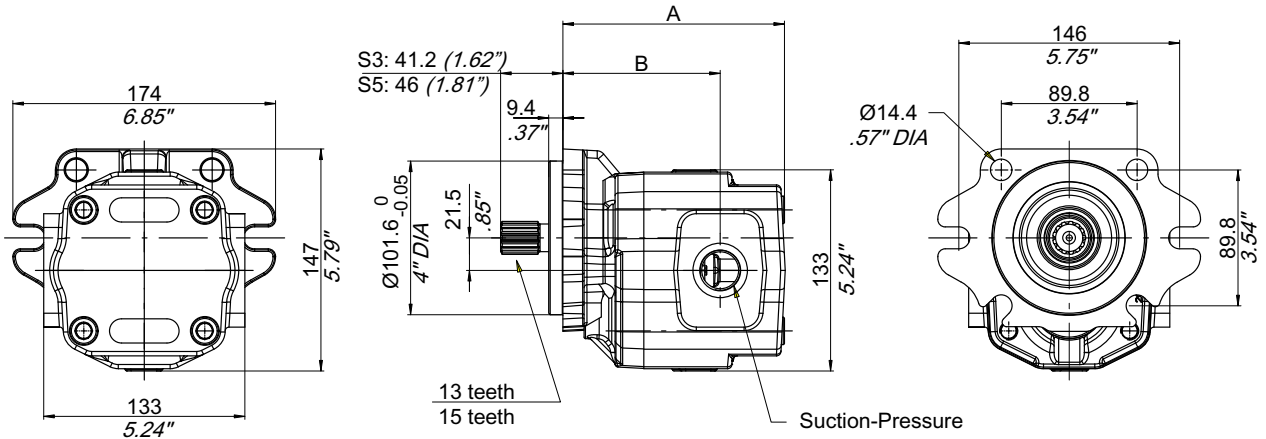
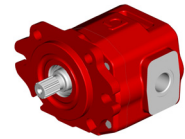

Type	A		B		Suction BSPP	Pressure BSPP
	mm	inches	mm	inches		
15	128	5.04	85.5	3.37	1"	3/4"
19	132	5.20	89.5	3.52		
23	136	5.35	93.5	3.68		
26	139.5	5.49	97	3.82		
29	142.5	5.61	100	3.94		
33	146.5	5.77	104	4.09		
36	149.5	5.89	102	4.02	1" 1/4	1"
40	154	6.06	106.5	4.19		
45	159	6.25	111.5	4.39		
50	164	6.46	116.5	4.59		
54	168	6.61	120.5	4.74		

Pump description example:

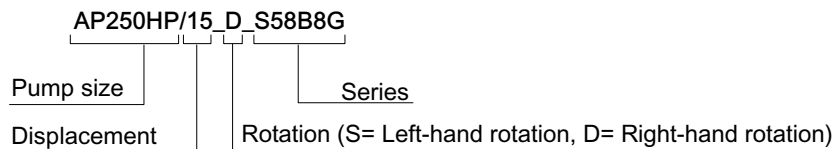

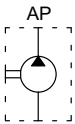

S38B8S
S58B8S

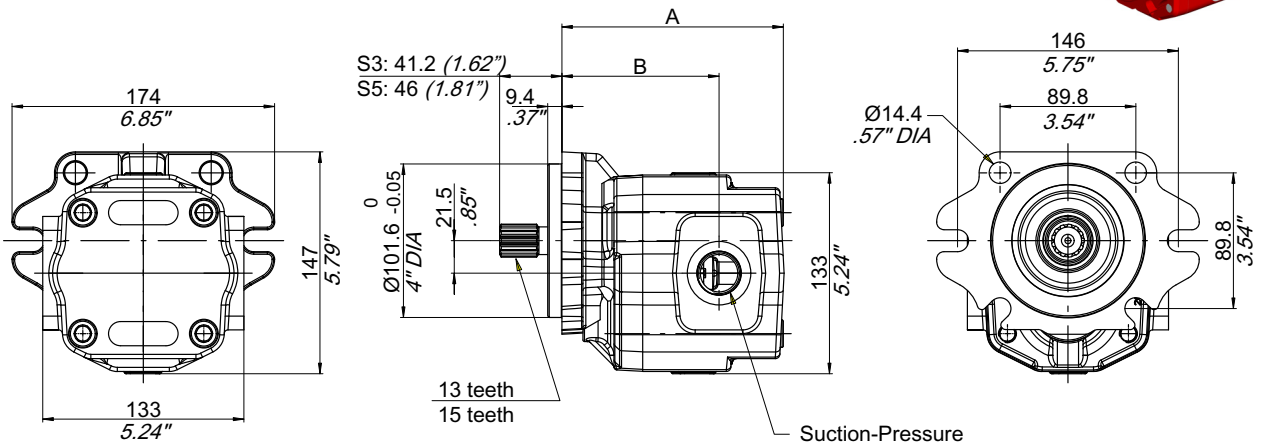
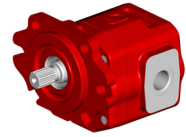

Type	A		B		Suction UNF	Pressure UNF
	mm	inches	mm	inches		
15	128	5.04	85.5	3.37	1" UNF-2B (SAE16)	3/4" UNF-2B (SAE12)
19	132	5.20	89.5	3.52		
23	136	5.35	93.5	3.68		
26	139.5	5.49	97	3.82		
29	142.5	5.61	100	3.94		
33	146.5	5.77	104	4.09	1 5/8" - 12 UNF-2B (SAE20)	1 5/16" - 12 UNF-2B (SAE16)
36	149.5	5.89	102	4.02		
40	154	6.06	106.5	4.19		
45	159	6.25	111.5	4.39		
50	164	6.46	116.5	4.59		
54	168	6.61	120.5	4.74		

Pump description example:

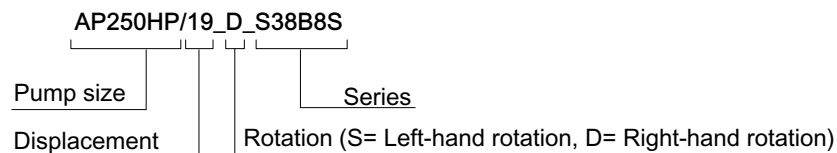

3 AP250HP Single pump customised versions

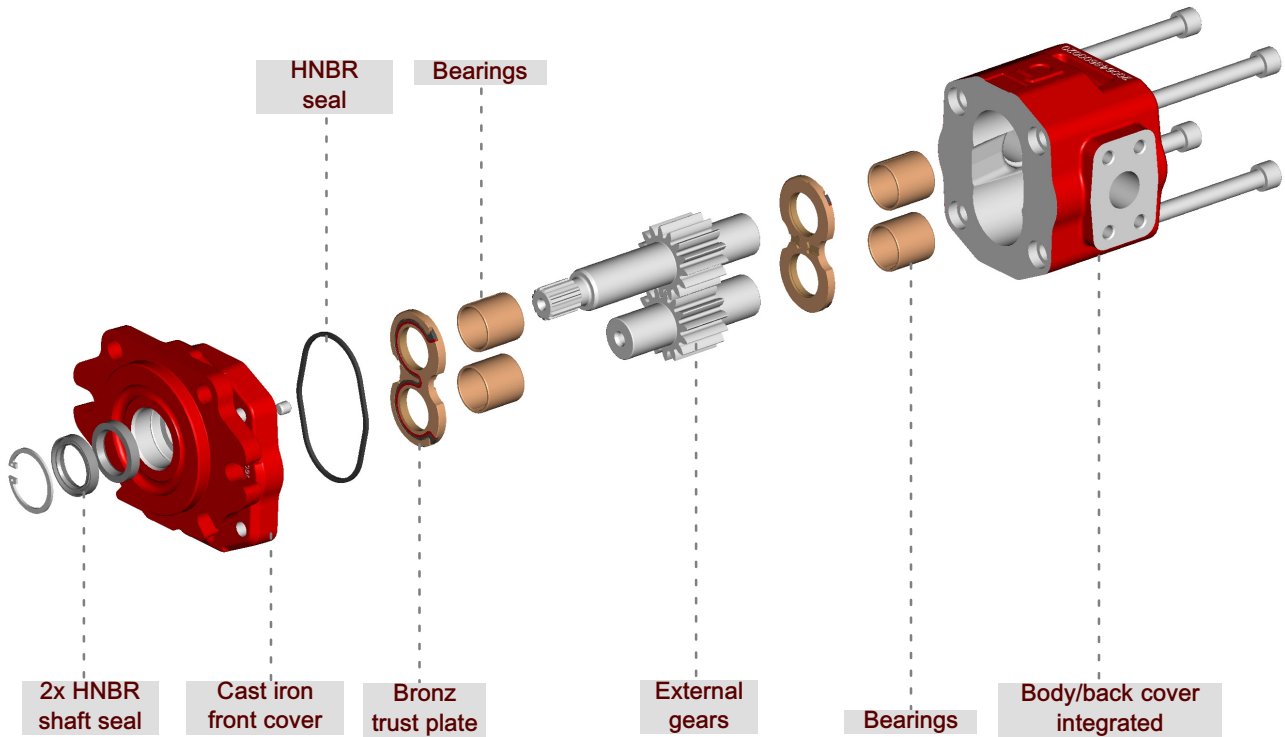

In this section, a single AP250HP pump can be configured and customized.

AP250HP wide availability of covers, bodies and gears provides great flexibility to AP250HP pump range and allows several different pump configurations.

In order to simplify the selection of the desired pump combination, a 'configurator form' is available and, by filling it out, it will guide you in the pump creation process.

3.1 Single pump customised versions order example

A	P	2	5	0	H	P	/	1	5	-	S	-	S	3	8	B	8	G	A	-										*
---	---	---	---	---	---	---	---	---	---	---	---	---	---	---	---	---	---	---	---	---	--	--	--	--	--	--	--	--	--	---

Function
AP= single gear pump - unidirectional

Series
250HP

Displacement
15= 15.2 cm³/rev
19= 19.1 cm³/rev
23= 23 cm³/rev
26= 26.4 cm³/rev
29= 29.3 cm³/rev
33= 33.2 cm³/rev
36= 36.1 cm³/rev
40= 40.5 cm³/rev
45= 45.3 cm³/rev
50= 50.2 cm³/rev
54= 54 cm³/rev

Rotation
S = Left-hand rotation
D = Right-hand rotation

Shaft end code
see section 3.3



Front cover type
see section 3.4.1

Type of ports code
see section 3.4.2

Inlet/outlet port size code combination
see section 3.4.2

Circuits/Valves option
see section 5

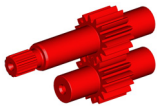
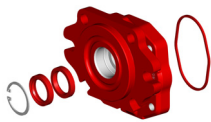
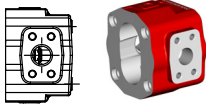
BHRE section :
Version - Progressive number (omitted)





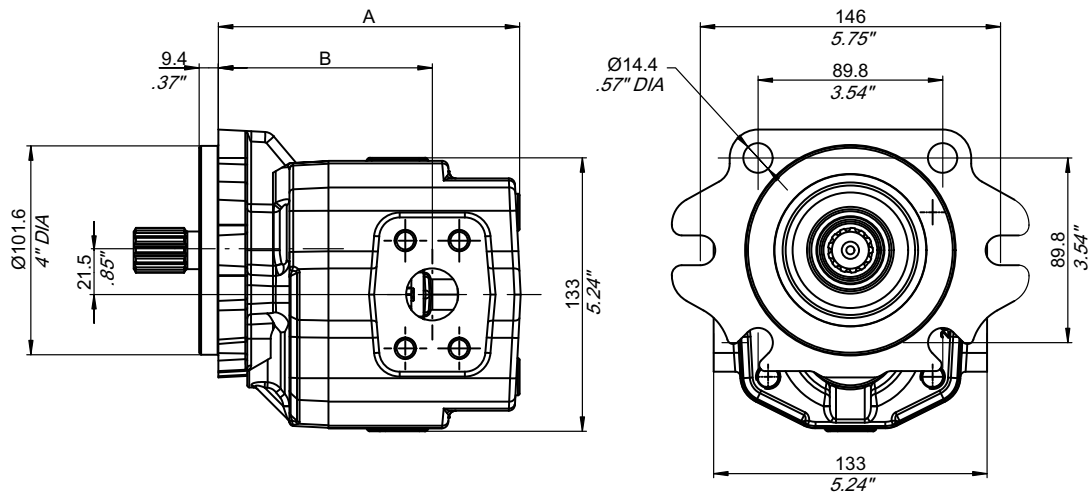

3.2 Single pump dimensions

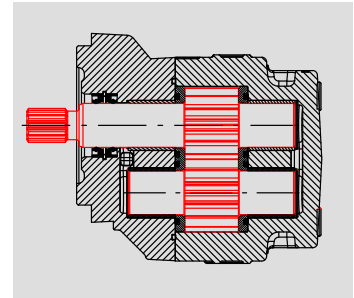
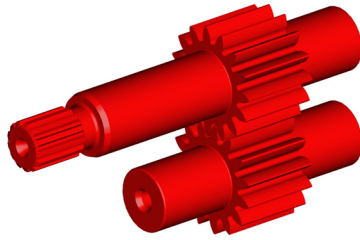

Pump size	A		B	
	mm	inches	mm	inches
AP250HP/15	128	5.04	85.5	3.37
AP250HP/19	132	5.20	89.5	3.52
AP250HP/23	136	5.35	93.5	3.68
AP250HP/26	139.5	5.49	97	3.82
AP250HP/29	142.5	5.61	100	3.94
AP250HP/33	146.5	5.77	104	4.09
AP250HP/36	149.5	5.89	102	4.02
AP250HP/40	154	6.06	106.5	4.19
AP250HP/45	159	6.25	111.5	4.39
AP250HP/50	164	6.46	116.5	4.59
AP250HP/54	168	6.61	120.5	4.74

3.3 Shaft end code

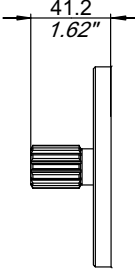
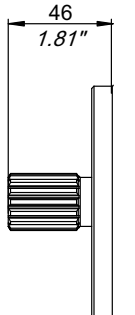

A P 2 5 0 H P / 1 5 - S - S 3

Shaft end shape	Shaft end ordering code	Max torque
	<p>13 teeth external spline SAE J 498-13T 16/32 DP</p> <p>S3</p>	<p>T max = 270 Nm</p>
	<p>15 teeth external spline SAE J 498-15T 16/32 DP</p> <p>S5</p>	<p>T max = 460 Nm</p>

3.4 Front cover/mounting flange

3.4.1 Front cover type

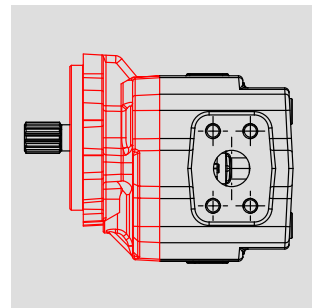
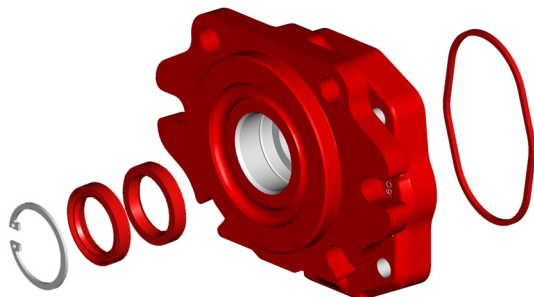

A P 2 5 0 H P / 1 5 - S - S 3 8 B



Type	Cast iron	
	Shape	Ordering code
SAE-B Two and four bolts (Ø 14,3 mm - 4 inches) with HNBR seals (shaft seals and O-ring)		8B

3.4.2 Body type

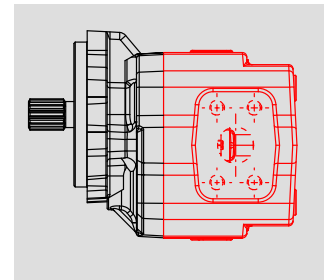
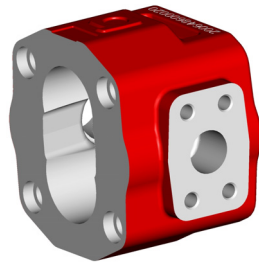

A P 2 5 0 H P / 1 5 - S - S 3 8 B 8 G A

Port type	Ordering code	Displacement	Dimension (mm - inches)		Ordering code
			Suction	Pressure	
 BSP Ports	8G	15-33	1" BSP	3/4" BSP	A
		36-54	1 1/4" BSP	1" BSP	B

3/4" BSP

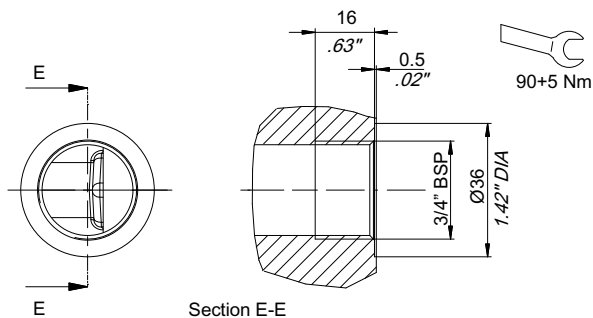

1" BSP

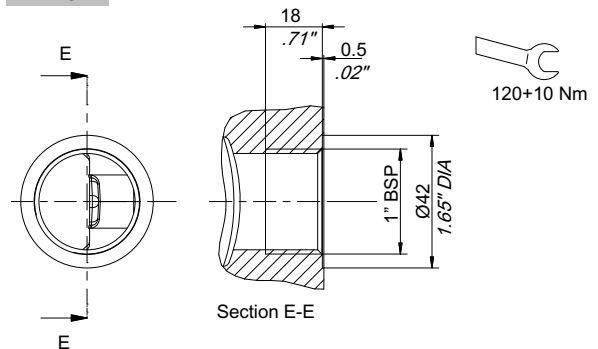

1 1/4" BSP

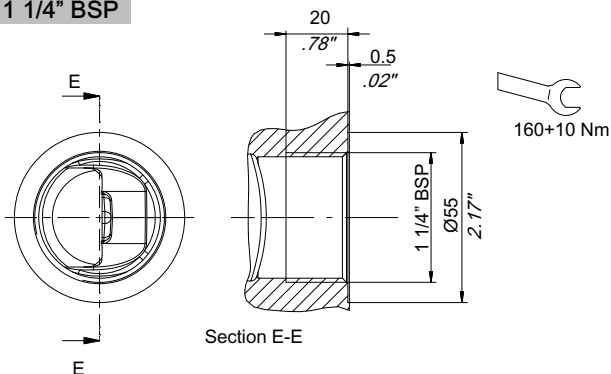

IMPORTANT!: Tightening torques depends on several different factors including lubrication, coating and surfaces finish. The fitting manufacturer shall be consulted.

In the interest of safety, only fittings with STRAIGHT THREAD ENDS should be used (e.g. DIN3852).

Fittings with TAPERED THREAD ENDS (e.g. DIN 3852 form C) should never be used, as they can cause deformation and cracks in the valve body.

Our warranty conditions will not be valid in case tapered fittings are used.

The work port adaptors have to be fastened respecting the tightening torque values indicated.

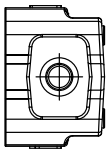
Port type	Ordering code	Displacement	Dimension (mm - inches)		Ordering code
			Suction	Pressure	
	8S	15-33	1" UNF-2B (SAE16)	3/4" UNF-2B (SAE12)	A
		36-54	1 5/8"-12 UNF-2B (SAE20)	1 5/16"-12 UNF-2B (SAE16)	B

3/4" UNF-2B (SAE12)

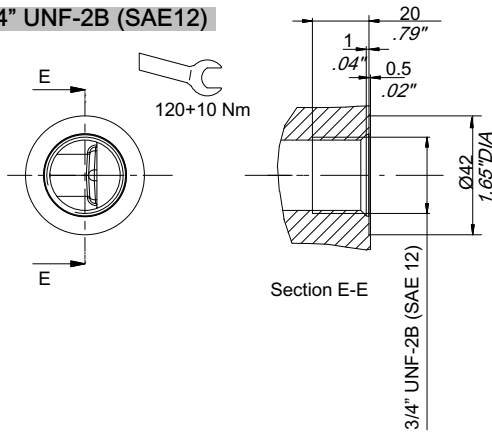

1" UNF-2B (SAE16)

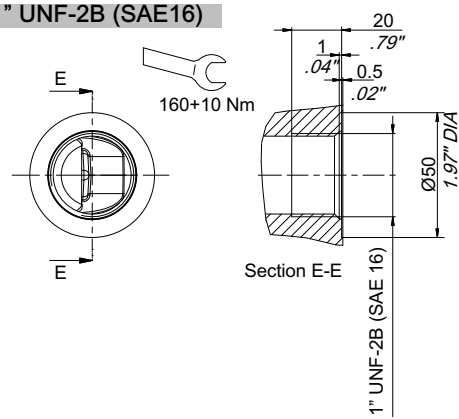

1 5/8"-12 UNF-2B (SAE20)

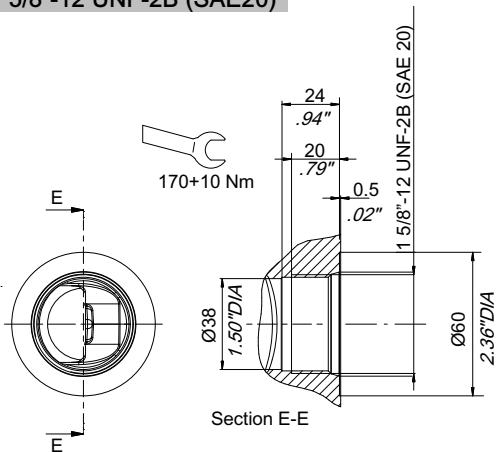

1 5/16" 12 UNF-2B (SAE16)

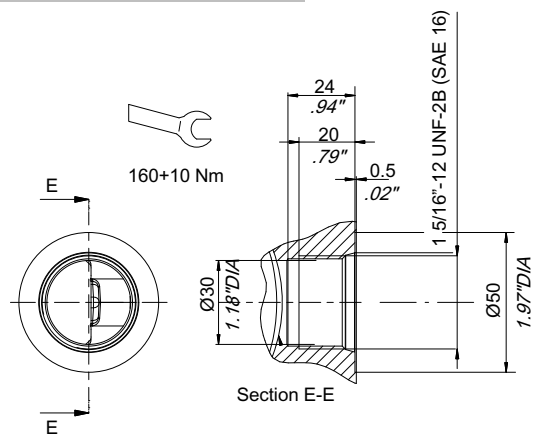

IMPORTANT!: Tightening torques depends on several different factors including lubrication, coating and surfaces finish. The fitting manufacturer shall be consulted.

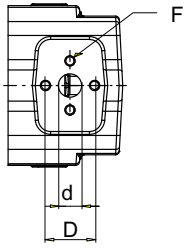
Port type	Ordering code	Displacement	Dimension (mm - inches)						Ordering code	
			Suction			Pressure				
			d	D	F	d	D	F		
	European n 4 bolt	2P	15-33	19 .75	40 1.57	M8x1.25	19 .75	40 1.57	M8x1.25	A
			36-54	25 .98	51 2.01	M10x1.5	19 .75	40 1.57	M8x1.25	B

2PA

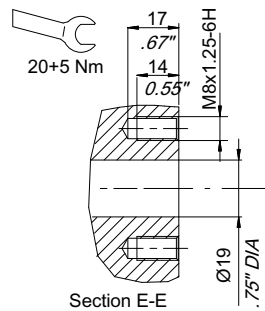
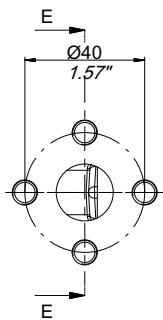

2PB

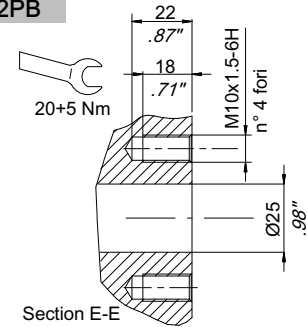
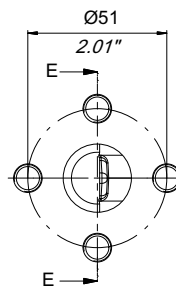

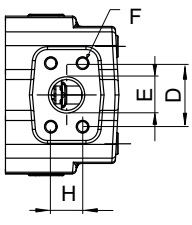
Port type	Ordering code	Displacement	Dimension (mm - inches)								Ordering code
			Suction				Pressure				
			H	D	E	F	H	D	E	F	
 <p>SAE FLANGED PORTS J518 (3000 PSI series)</p>	2S	15-23	26.19 1.03	52.37 2.06	25.4 1	M10 x1.5	22.23 .88	47.63 1.88	19 .75	M10 x1.5	A
		26-40	30.17 1.19	58.72 2.31	31.8 1.25	M10 x1.5	26.19 1.03	52.37 2.06	25.4 1	M10 x1.5	B
		45-54	35.71 1.14	69.85 2.75	38.1 1.5	M12 x1.75	26.19 1.03	52.37 2.06	25.4 1	M10 x1.5	C

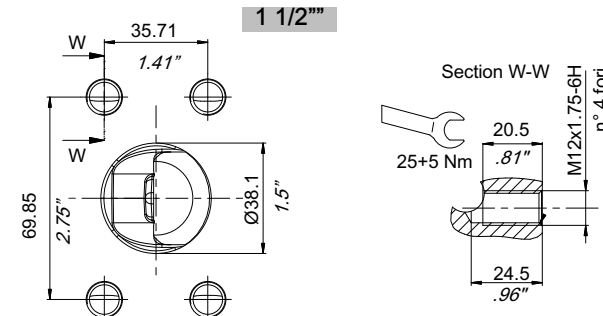
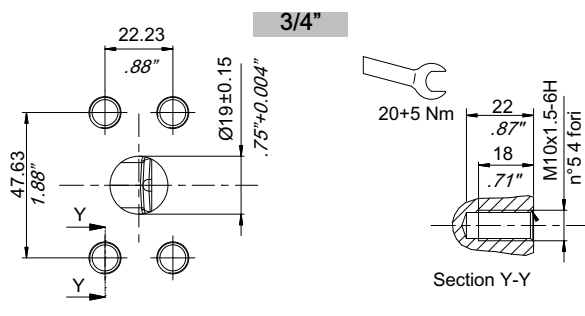
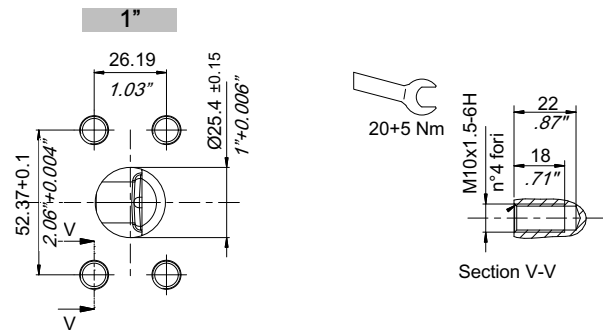
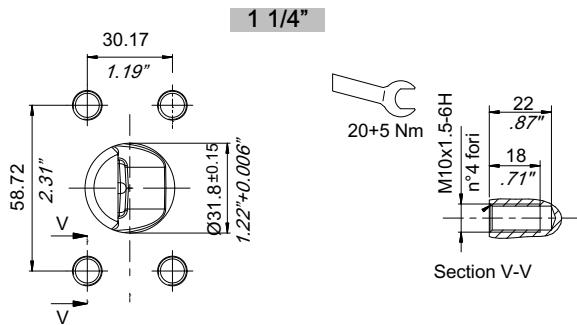

Other ports	9	If the requested port type is not included in the previous versions, please indicate number "9" and specify the details in the request note
-------------	---	---

4 Multiple gear pumps

4.1 Multiple gear pumps: AP250HP+AP250HP standard versions

Standard versions means separated inlet/outlet side ports, without shaft seal between pump stages

4.1.1 Drive torque calculation example

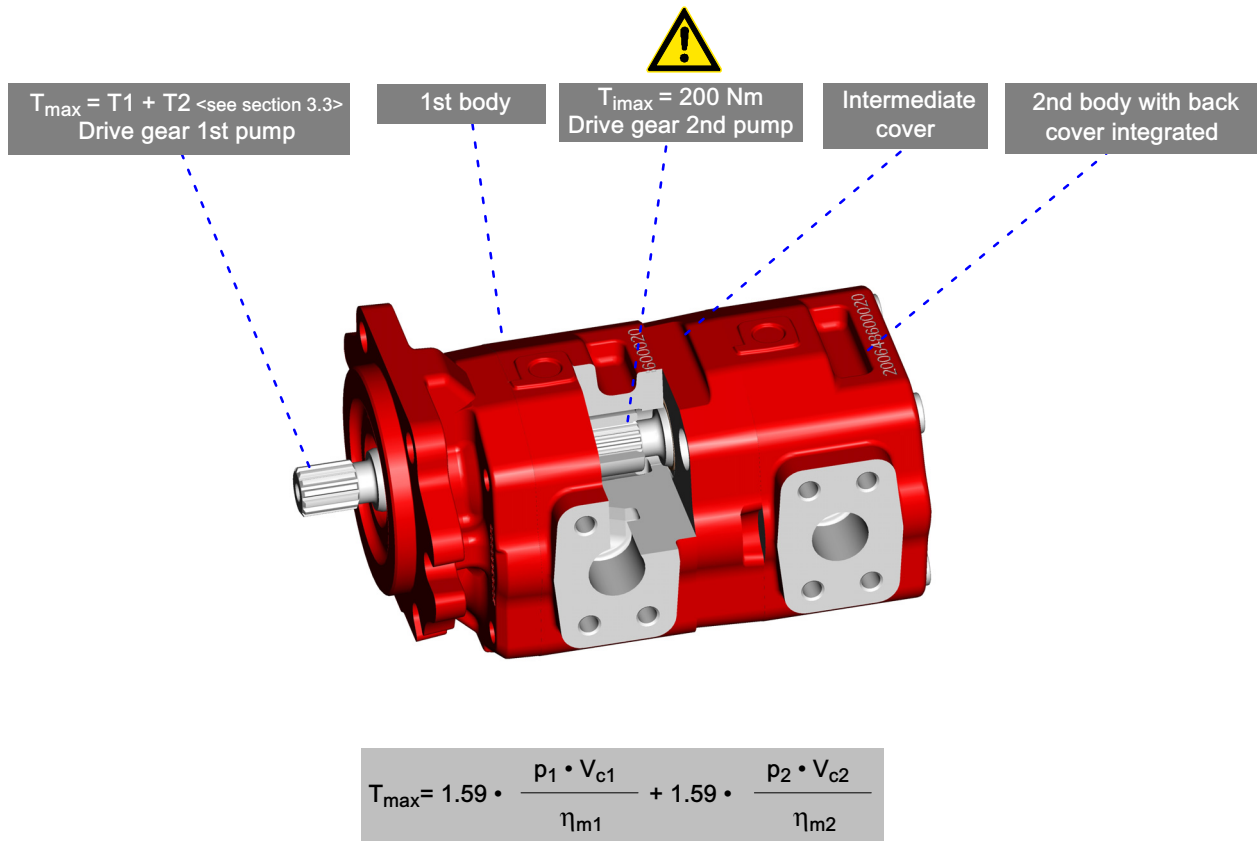

Example: AP250HP/36 + AP250HP/36

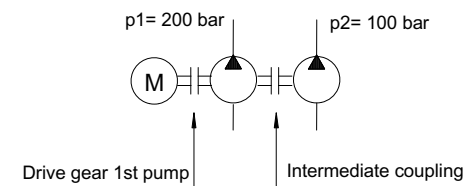

$$T_{\max} = 1.59 \cdot \frac{36 \cdot 200}{90} + 1.59 \cdot \frac{36 \cdot 100}{90} = 127.2 + 63.6 = 190.8 \text{ Nm}$$

$$T_{\max} = 190.8 \leq 270 \text{ Nm}$$

(splined 13T)

$$T_2 = 63.6 \leq T_{\max} 200 \text{ Nm}$$

Common suction versions available on request.
Please contact our Sales Department.

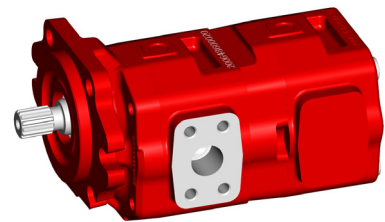

4.1.2 Tandem pumps dimensions

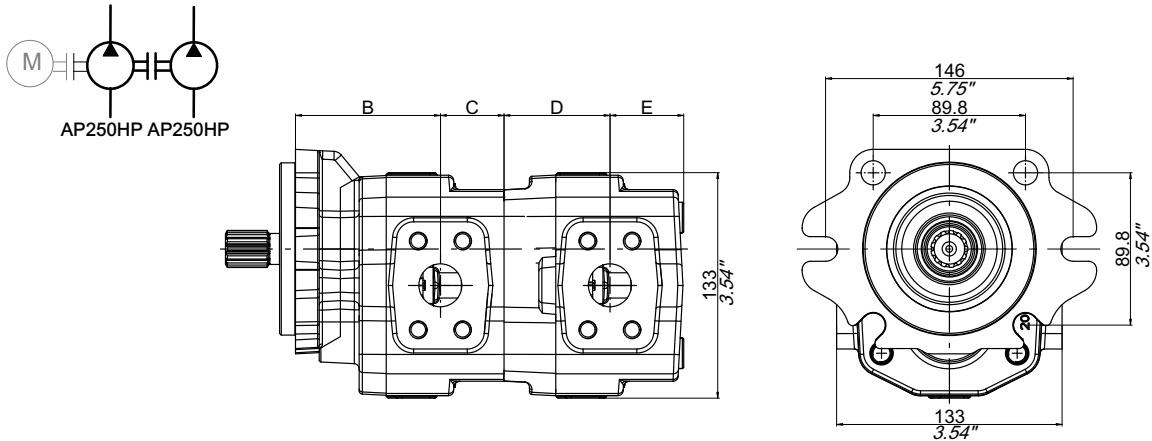

Pump size	B		C		D		E	
	mm	inches	mm	inches	mm	inches	mm	inches
AP250HP/15	85.5	3.37	37.5	1.48	62.5	2.46	42.5	1.67
AP250HP/19	89.5	3.52	37.5	1.48	66.5	2.62	42.5	1.67
AP250HP/23	93.5	3.68	37.5	1.48	70.5	2.78	42.5	1.67
AP250HP/26	97	3.82	37.5	1.48	74	2.91	42.5	1.67
AP250HP/29	100	3.94	37.5	1.48	77	3.03	42.5	1.67
AP250HP/33	104	4.09	37.5	1.48	81	3.19	42.5	1.67
AP250HP/36	102	4.02	42.5	1.67	79	3.11	47.5	1.87
AP250HP/40	106.5	4.19	42.5	1.67	83.5	3.29	47.5	1.87
AP250HP/45	111.5	4.39	42.5	1.67	88.5	3.48	47.5	1.87
AP250HP/50	116.5	4.59	42.5	1.67	93.5	3.68	47.5	1.87
AP250HP/54	120.5	4.74	42.5	1.67	97.5	3.84	47.5	1.87

4.1.3 Dimensions example

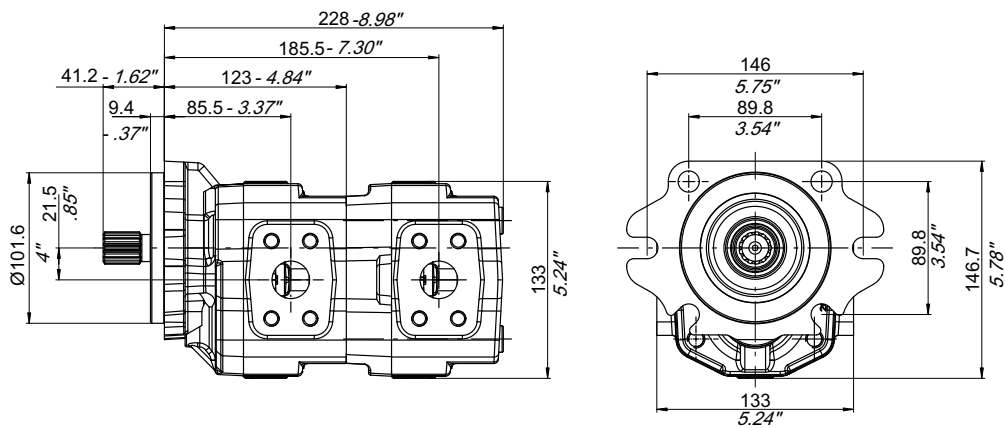

Example AP250HP/15+AP250HP/15:

Total length: $229 = (B+C+D+E)$ $85.5+37.5+62.5+42.5$

Port position: $85.5 = (B)$

$185.5 = (B+C+D)$ $85.5+37.5+62.5$

4.1.4 How to order tandem pumps AP250HP+AP250HP standard versions

1st PUMP										2nd PUMP		1st BODY		2nd BODY																	
1	2					3	3	4	5	6	7	8	7	8																	
A	P	2	5	0	H	P	/	3	6	-	3	6	-	S	-	S	3	8	B	8	G	A	-	8	G	A	-				

1 Function

AP= single gear pump - unidirectional

2 Series

250HP

3 Displacement

15= 15.2 cm³/rev
 19= 19.1 cm³/rev
 23= 23 cm³/rev
 26= 26.4 cm³/rev
 29= 29.3 cm³/rev
 33= 33.2 cm³/rev
 36= 36.1 cm³/rev
 40= 40.5 cm³/rev
 45= 45.3 cm³/rev
 50= 50.2 cm³/rev
 54= 54 cm³/rev

4 Rotation

S = left-hand rotation
 D = Right-hand rotation

5 Shaft end code

see section 3.3

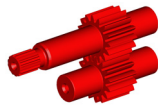

6 Front cover type

see section 3.4.1

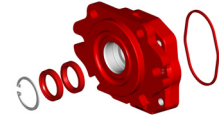

7 Type of ports code

see section 3.4.2

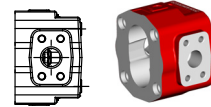

8 Inlet/outlet port size code combination

see section 3.4.2



9 BHRE section : Version - Progressive number (omitted)

4.2 Multiple gear pumps: AP250HP+AP250HP+AP250HP standard versions

Standard versions means separated inlet/outlet side ports, without shaft seal between pump stages

4.2.1 Drive torque calculation example

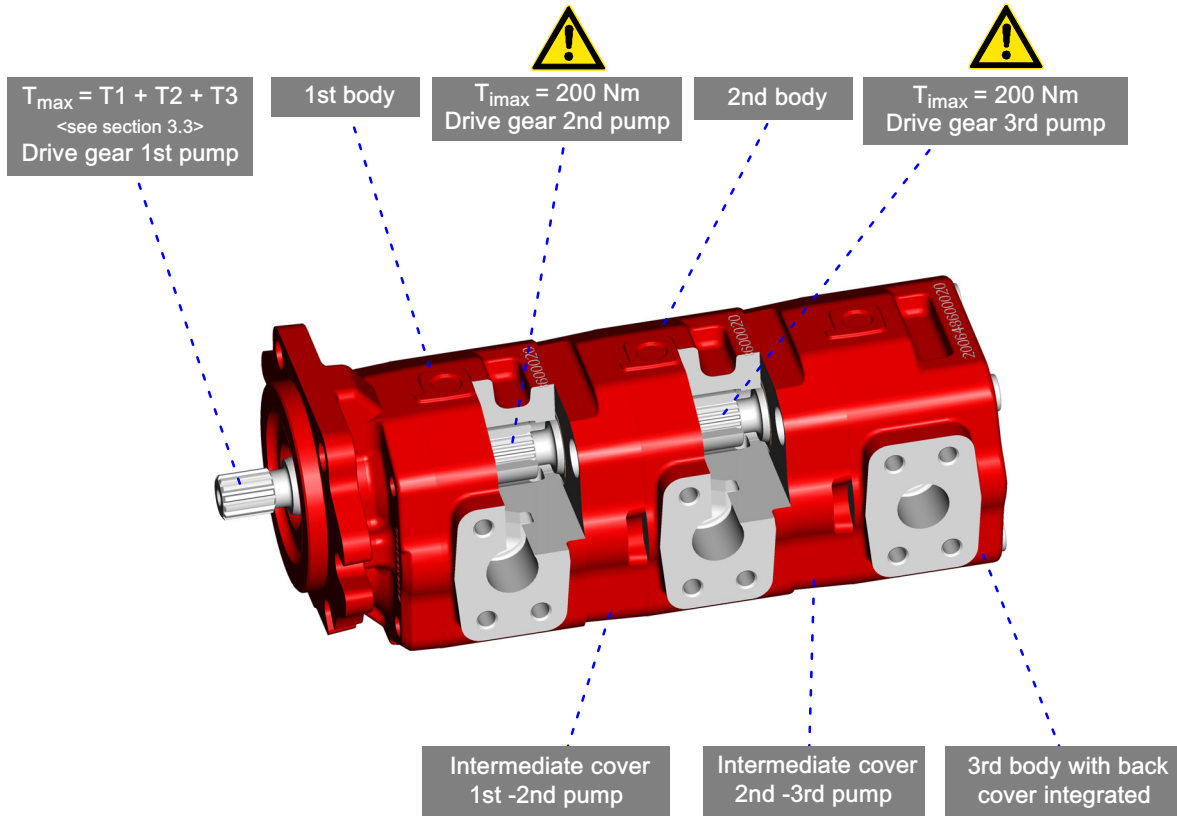

$$T_{\max} = 1.59 \cdot \frac{p_1 \cdot V_{c1}}{\eta_{m1}} + 1.59 \cdot \frac{p_2 \cdot V_{c2}}{\eta_{m2}} + 1.59 \cdot \frac{p_3 \cdot V_{c3}}{\eta_{m3}}$$

Example: AP250HP/36 + AP250HP/23 + AP250HP/15

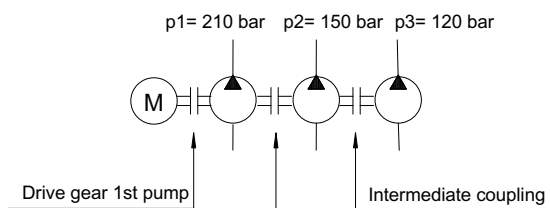

$$T_{\max} = 1.59 \cdot \frac{36 \cdot 210}{90} + 1.59 \cdot \frac{23 \cdot 150}{90} + 1.59 \cdot \frac{15 \cdot 120}{90} = 133.6 + 61 + 32 = 226.6 \text{ Nm}$$

$$T_{\max} = 226.6 \leq 270 \text{ Nm (splined 13T)}$$

$$T_2 = 61 \leq T_{\max} 200 \text{ Nm} \quad T_3 = 32 \leq T_{\max} 200 \text{ Nm}$$

Common suction versions available on request.
Please contact our Sales Department.

4.2.2 Triple/multiple pumps dimensions

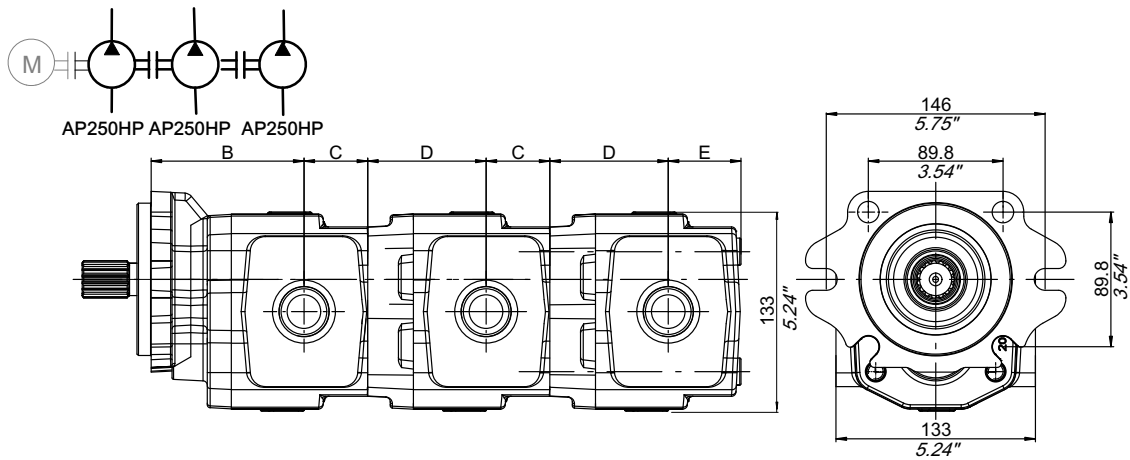

Pump size	B		C		D		E	
	mm	inches	mm	inches	mm	inches	mm	inches
AP250HP/15	85.5	3.37	37.5	1.48	62.5	2.46	42.5	1.67
AP250HP/19	89.5	3.52	37.5	1.48	66.5	2.62	42.5	1.67
AP250HP/23	93.5	3.68	37.5	1.48	70.5	2.78	42.5	1.67
AP250HP/26	97	3.82	37.5	1.48	74	2.91	42.5	1.67
AP250HP/29	100	3.94	37.5	1.48	77	3.03	42.5	1.67
AP250HP/33	104	4.09	37.5	1.48	81	3.19	42.5	1.67
AP250HP/36	102	4.02	42.5	1.67	79	3.11	47.5	1.87
AP250HP/40	106.5	4.19	42.5	1.67	83.5	3.29	47.5	1.87
AP250HP/45	111.5	4.39	42.5	1.67	88.5	3.48	47.5	1.87
AP250HP/50	116.5	4.59	42.5	1.67	93.5	3.68	47.5	1.87
AP250HP/54	120.5	4.74	42.5	1.67	97.5	3.84	47.5	1.87

4.2.3 Dimensions example

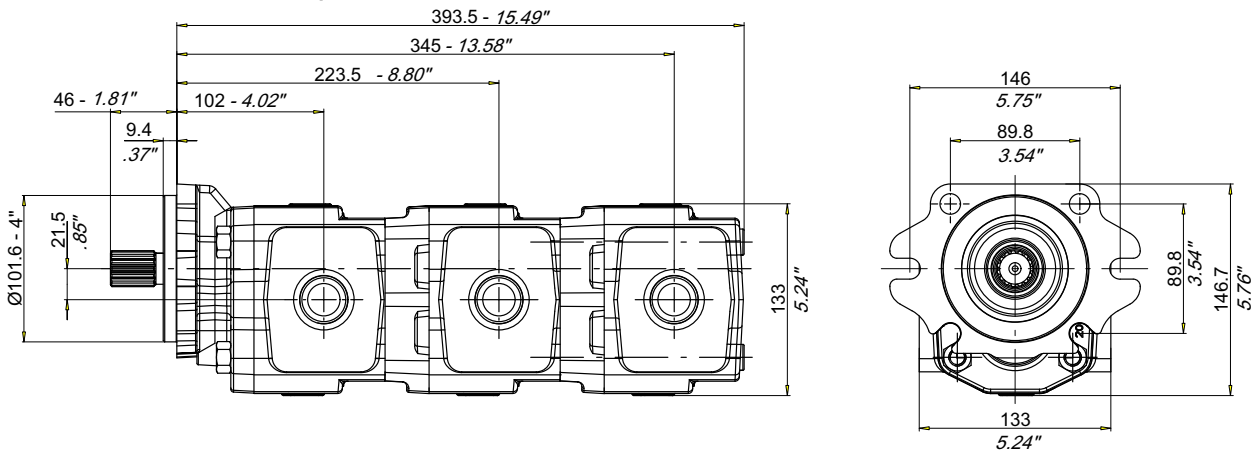

Example AP250HP/36+AP250HP/36+AP250HP/36:

Total length: $393.5 = (B+C+D+C+D+E)$ $102+42.5+79+42.5+79+42.5$

Port position: $102 = (B)$

$223.5 = (B+C+D)$ $102+42.5+79$

$345 = (B+C+D+C+D)$ $102+42.5+79+42.5+79$

4.2.4 How to order triple pumps AP250HP+AP250HP+AP250HP standard versions

	1st PUMP						2nd PUMP		3rd PUMP			1st BODY		2nd BODY		3rd BODY																				
1	2					3	3	3	3	3	4	5	6	7	8	7	8	7	8																	
A	P	2	5	0	H	P	/	4	5	-	3	6	-	3	6	-	S	-	S	3	8	B	8	G	A	-	8	G	A	-	8	G	A			

1 Function

AP= single gear pump - unidirectional

2 Series

250HP

3 Displacement

15= 15.2 cm³/rev
 19= 19.1 cm³/rev
 23= 23 cm³/rev
 26= 26.4 cm³/rev
 29= 29.3 cm³/rev
 33= 33.2 cm³/rev
 36= 36.1 cm³/rev
 40= 40.5 cm³/rev
 45= 45.3 cm³/rev
 50= 50.2 cm³/rev
 54= 54 cm³/rev

4 Rotation

S = left-hand rotation
 D = Right-hand rotation

5 Shaft end code

see section 3.3

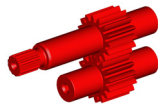

6 Front cover type

see section 3.4.1

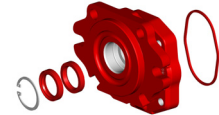

7 Type of ports code

see section 3.4.2

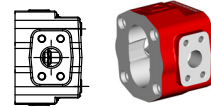

8 Inlet/outlet port size code combination

see section 3.4.2

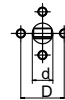

9 BHRE section :

Version - Progressive number (omitted)

4.3 Multiple gear pumps: AP250HP+AP212 standard versions

Standard versions means separated inlet/outlet side ports, without shaft seal between pump stages

4.3.1 Drive torque calculation example

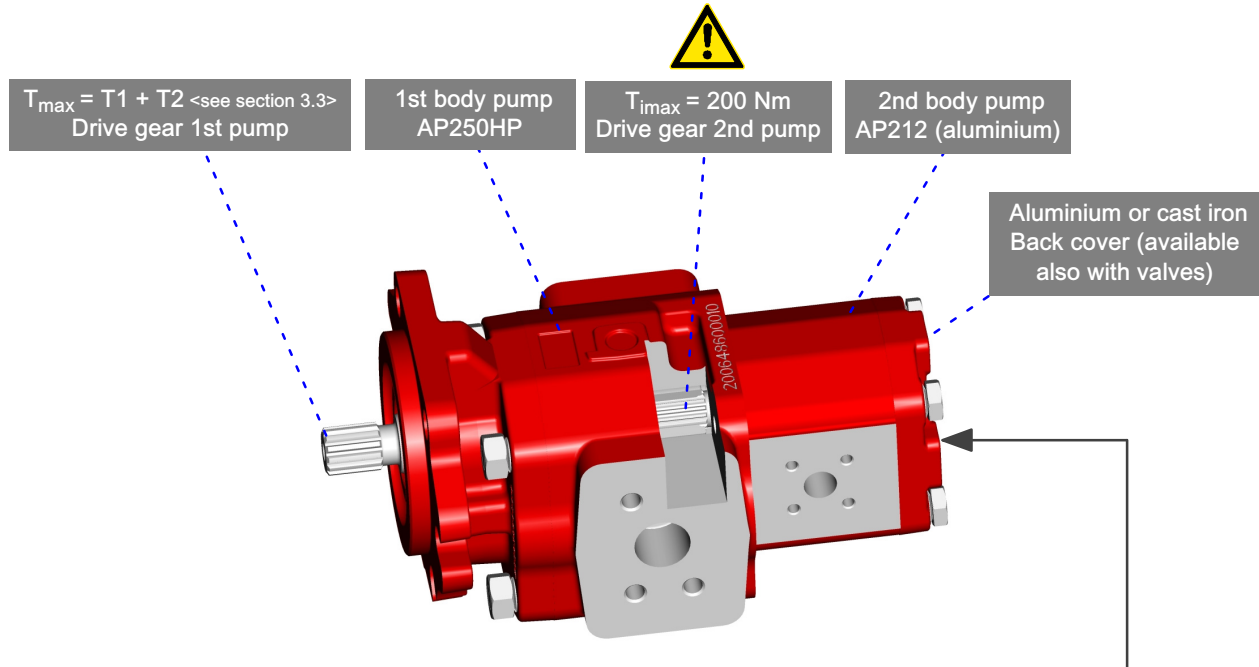

$$T_{\max} = 1.59 \cdot \frac{p_1 \cdot V_{c1}}{\eta_{m1}} + 1.59 \cdot \frac{p_2 \cdot V_{c2}}{\eta_{m2}}$$

Example: AP250HP/33 + AP212/19

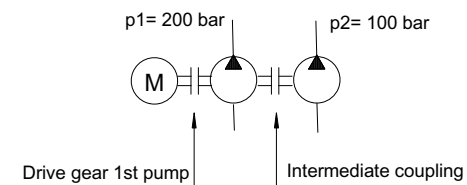

$$T_{\max} = 1.59 \cdot \frac{33 \cdot 200}{90} + 1.59 \cdot \frac{19 \cdot 100}{90} = 116.6 + 33.57 = 150.17 \text{ Nm}$$

$$T_{\max} = 150.17 \leq 270 \text{ Nm (splined 13T)}$$

$$T_2 = 33.57 \leq T_{\max} 200 \text{ Nm}$$

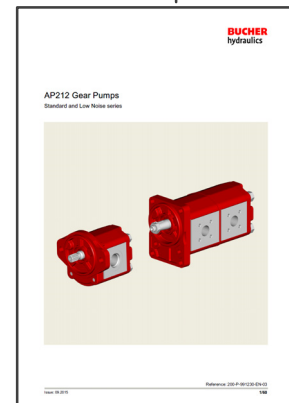

Further information regarding group 2 pumps: see dedicated "AP212 Gear Pumps" catalogue

Common suction versions available on request. Please contact our Sales Department.

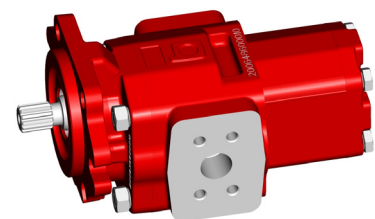

4.3.2 AP250HP + AP212 pumps dimensions

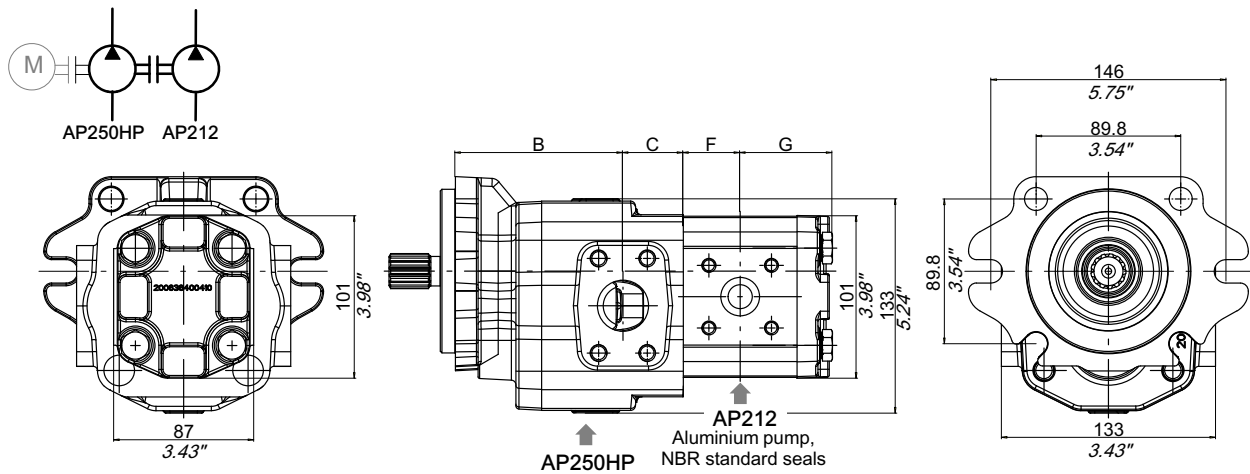

Pump size AP250HP	B		C	
	mm	inches	mm	inches
AP250HP/15	85.5	3.37	37.5	1.48
AP250HP/19	89.5	3.52	37.5	1.48
AP250HP/23	93.5	3.68	37.5	1.48
AP250HP/26	97	3.82	37.5	1.48
AP250HP/29	100	3.94	37.5	1.48
AP250HP/33	104	4.09	37.5	1.48
AP250HP/36	102	4.02	42.5	1.67
AP250HP/40	106.5	4.19	42.5	1.67
AP250HP/45	111.5	4.39	42.5	1.67
AP250HP/50	116.5	4.59	42.5	1.67
AP250HP/54	120.5	4.74	42.5	1.67

Pump size AP212	F		G	
	mm	inches	mm	inches
AP212/4.5	24.3	0.96	46.6	1.83
AP212/6.5	25.8	1.02	48.1	1.89
AP212/8.5	27.3	1.08	49.6	1.95
AP212/11	29.3	1.54	51.6	2.03
AP212/15	32.3	1.27	54.6	2.15
AP212/19	35.3	1.39	57.6	2.27
AP212/22	37.6	1.48	59.9	2.36
AP212/26	40.6	1.60	62.9	2.48

4.3.3 Dimensions example

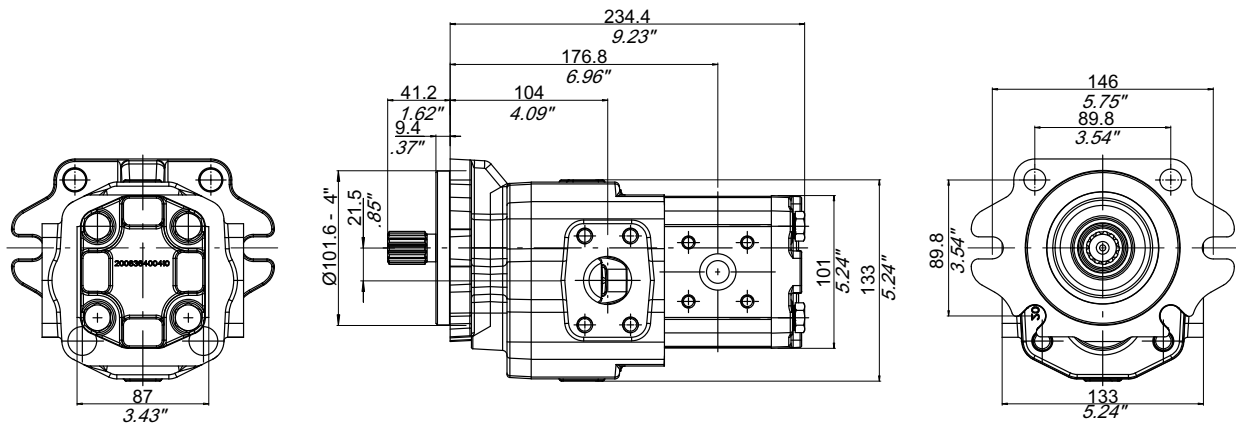

Example AP250HP/33+AP212/19:

Total length: $234.4 = (B+C+F+G) 104+37.5+35.3+57.6$

Port position: $176.8 = (B+C+F) 104+37.5+35.3$
 $104 = (B)$

4.3.4 How to order tandem pumps AP250HP + AP212 standard versions

1st PUMP			2nd PUMP			1st BODY AP250HP		2nd BODY AP212																											
1	2		3		22		23		4		5		6		7		8		27		28		29		30										
A	P	2	5	0	H	P	/	3	3	-	2	1	2	/	1	9	-	S	-	S	3	8	B	8	G	A	-	4	A	N	-	G	H		

AP250HP

1 Function

AP= single gear pump - unidirectional

2 Series

250HP

3 Displacement

15= 15.2 cm³/rev
 19= 19.1 cm³/rev
 23= 23 cm³/rev
 26= 26.4 cm³/rev
 29= 29.3 cm³/rev
 33= 33.2 cm³/rev
 36= 36.1 cm³/rev
 40= 40.5 cm³/rev
 45= 45.3 cm³/rev
 50= 50.2 cm³/rev
 54= 54 cm³/rev

4 Rotation

S = left-hand rotation
 D = Right-hand rotation

5 Shaft end code

see section 3.3

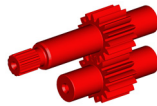

6 Front cover type

see section 3.4.1

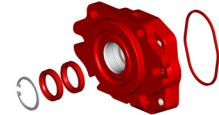

7 Type of ports code

see section 3.4.2

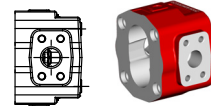

8 Inlet/outlet port size code combination

see section 3.4.2



9 BHRE section :

Version - Progressive number (omitted)

AP212 - AP212HP

22 Series

212 (Aluminium)
 212HP (Cast iron)

23 Displacement

212	212HP
4.5= 4.4 cm ³ /rev	15= 15.1 cm ³ /rev
6.5= 6.4 cm ³ /rev	19= 19.2 cm ³ /rev
8.5= 8.4 cm ³ /rev	22= 22.2 cm ³ /rev
11= 11.1 cm ³ /rev	26= 26.2 cm ³ /rev
15= 15.1 cm ³ /rev	29= 28.9 cm ³ /rev
19= 19.2 cm ³ /rev	33= 33 cm ³ /rev
22= 22.2 cm ³ /rev	
26= 26.2 cm ³ /rev	

24 Version

Omitted if 12 teeth standard
 LN= 12 teeth Low Noise version

27 Type of ports code

see section 3.5 AP212 and AP212HP Catalogues

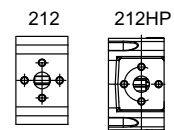

28 Inlet/outlet port size code combination

see section 3.5 AP212 and AP212HP Catalogues



29 Body material + seal material code

see section 3.5.1 AP212 and AP212HP Catalogues

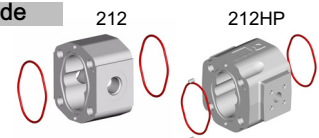

30 Back cover type / Valve setting value

see section 3.6 AP212 and AP212HP Catalogues

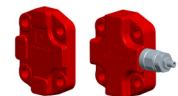

4.4 Multiple gear pumps: AP250HP+AP212+AP212 standard versions

Standard versions means separated inlet/outlet side ports, without shaft seal between pump stages

4.4.1 Drive torque calculation example

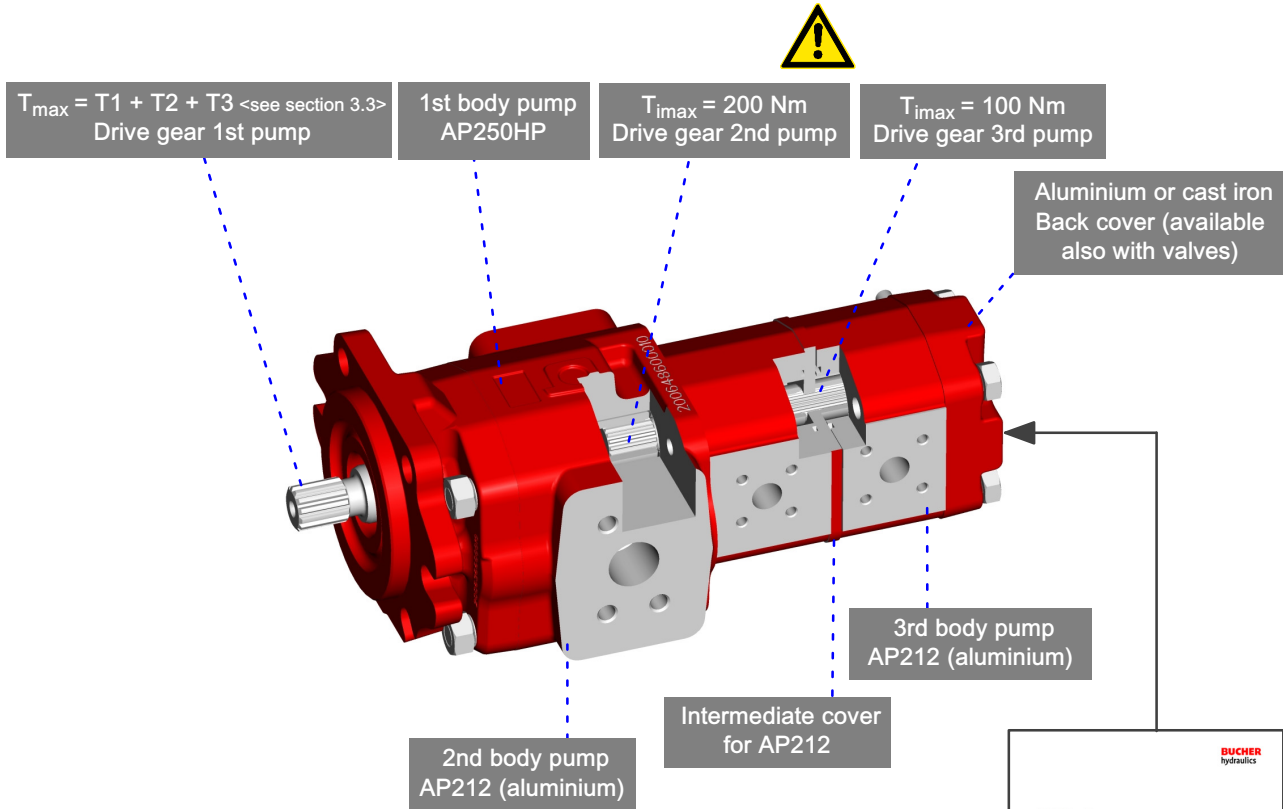

$$T_{max} = 1.59 \cdot \frac{p_1 \cdot V_{c1}}{\eta_{m1}} + 1.59 \cdot \frac{p_2 \cdot V_{c2}}{\eta_{m2}} + 1.59 \cdot \frac{p_3 \cdot V_{c3}}{\eta_{m3}}$$

Example: AP250HP/40 + AP212/15 + AP250HP/6.5
 $p_1 = 210$ bar $p_2 = 150$ bar $p_3 = 120$ bar

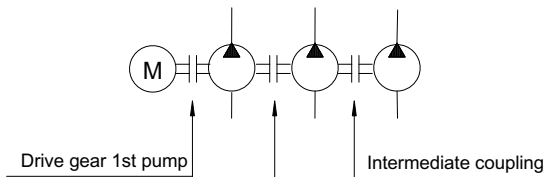

Further information regarding group 2 pumps: see dedicated "AP212 Gear Pumps" catalogue

$$T_{max} = 1.59 \cdot \frac{40 \cdot 210}{90} + 1.59 \cdot \frac{15 \cdot 150}{90} + 1.59 \cdot \frac{6.5 \cdot 120}{90} = 148.4 + 39.75 + 13.78 = 201.93 \text{ Nm}$$

$$T_{max} = 201.93 \leq 270 \text{ Nm (splined 13T)}$$

$$T_2 = 39.75 \leq T_{imax} 200 \text{ Nm}$$

Common suction versions available on request.
Please contact our Sales Department.

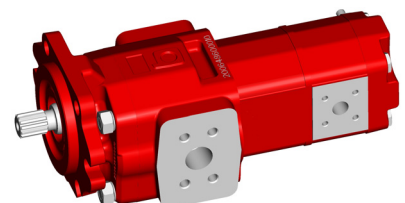

4.4.2 AP250HP + AP212 + AP212 pumps dimensions

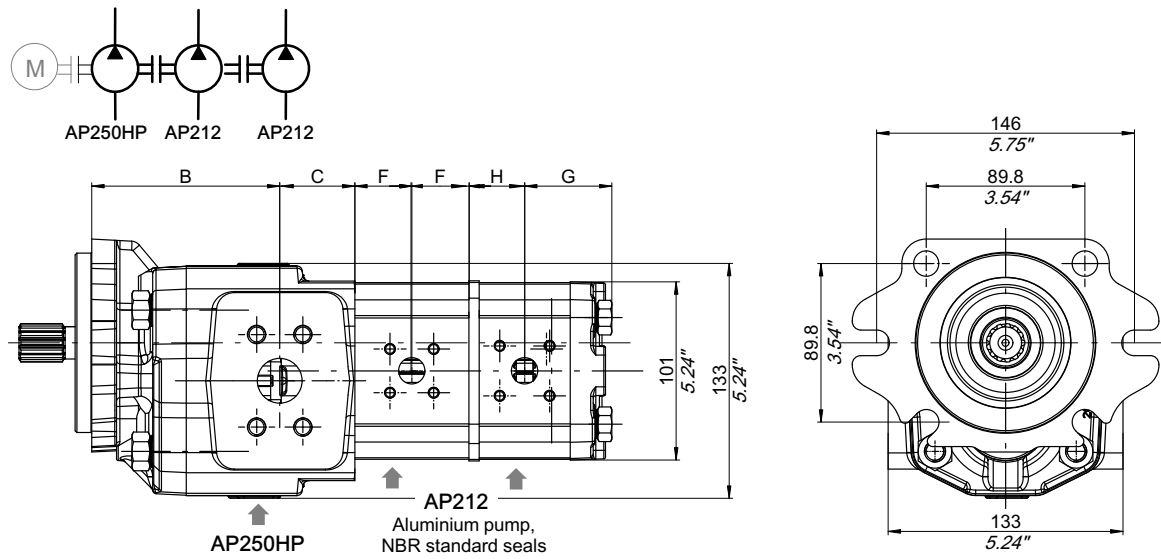

Pump size AP250HP	B		C	
	mm	inches	mm	inches
AP250HP/15	85.5	3.37	37.5	1.48
AP250HP/19	89.5	3.52	37.5	1.48
AP250HP/23	93.5	3.68	37.5	1.48
AP250HP/26	97	3.82	37.5	1.48
AP250HP/29	100	3.94	37.5	1.48
AP250HP/33	104	4.09	37.5	1.48
AP250HP/36	102	4.02	42.5	1.67
AP250HP/40	106.5	4.19	42.5	1.67
AP250HP/45	111.5	4.39	42.5	1.67
AP250HP/50	116.5	4.59	42.5	1.67
AP250HP/54	120.5	4.74	42.5	1.67

Pump size AP212	F		G		H		H* (with shaft seal between pumps)	
	mm	inches	mm	inches	mm	inches	mm	inches
AP212/4.5	24.3	0.96	46.6	1.83	30.1	1.19	46.6	1.83
AP212/6.5	25.8	1.02	48.1	1.89	31.6	1.24	48.1	1.89
AP212/8.5	27.3	1.08	49.6	1.95	33.1	1.30	49.6	1.95
AP212/11	29.3	1.54	51.6	2.03	35.1	1.38	51.6	2.03
AP212/15	32.3	1.27	54.6	2.15	38.1	1.50	54.6	2.15
AP212/19	35.3	1.39	57.6	2.27	41.1	1.62	57.6	2.27
AP212/22	37.6	1.48	59.9	2.36	43.4	1.71	59.9	2.36
AP212/26	40.6	1.60	62.9	2.48	46.4	1.83	62.9	2.48

4.4.3 Dimensions example

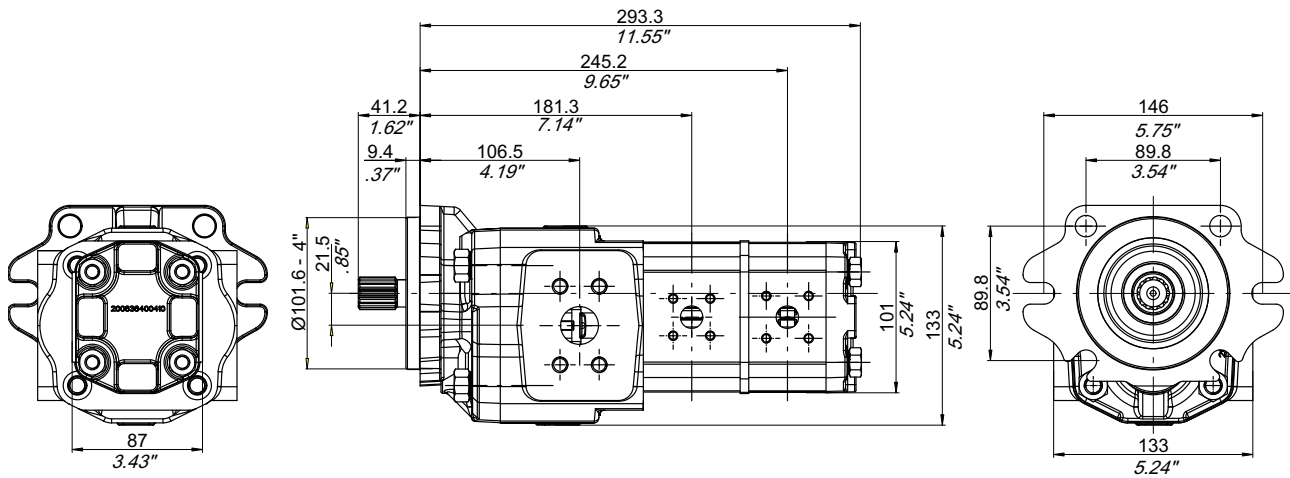

Example: AP250HP/40+AP212/15+AP212/6.5

Total length: $293.3 = (B+C+F+F+H+G)$ $106.5+42.5+32.3+32.3+31.6+48.1$

Port position: $106.5 = (B)$

$181.3 = (B+C+F)$ $106.5+42.5+32.3$

$245.2 = (B+C+F+F+H)$ $106.5+42.5+32.3+32.3+31.6$

4.4.4 How to order triple pumps AP250HP + AP212 + AP212 standard versions

1st PUMP			2nd PUMP			3rd PUMP			1st BODY AP250HP			2nd BODY AP212			3rd BODY AP212																												
1	2	3	22	23	23	4	5	6	7	8		27	28	29	27	28	29	30	31																								
A	P	2	5	0	H	P	/	3	3	-	2	1	2	/	1	9	-	1	1	-	S	-	S	3	8	B	8	G	A	-	8	A	N	-	8	A	N	-	V	E	1	6	

AP250HP

1 Function

AP= single gear pump - unidirectional

2 Series

250HP

3 Displacement

15= 15.2 cm³/rev
 19= 19.1 cm³/rev
 23= 23 cm³/rev
 26= 26.4 cm³/rev
 29= 29.3 cm³/rev
 33= 33.2 cm³/rev
 36= 36.1 cm³/rev
 40= 40.5 cm³/rev
 45= 45.3 cm³/rev
 50= 50.2 cm³/rev
 54= 54 cm³/rev

4 Rotation

S = left-hand rotation
 D = Right-hand rotation

5 Shaft end code

see section 3.3

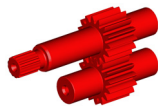

6 Front cover type

see section 3.4.1



7 Type of ports code

see section 3.4.2

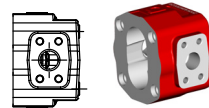

8 Inlet/outlet port size code combination

see section 3.4.2



9 BHRE section : Version - Progressive number (omitted)

AP212 - AP212HP

22 Series

212 (Aluminium)
 212HP (Cast iron)

23 Displacement

212	212HP
4.5= 4.4 cm ³ /rev	15= 15.1 cm ³ /rev
6.5= 6.4 cm ³ /rev	19= 19.2 cm ³ /rev
8.5= 8.4 cm ³ /rev	22= 22.2 cm ³ /rev
11= 11.1 cm ³ /rev	26= 26.2 cm ³ /rev
15= 15.1 cm ³ /rev	29= 28.9 cm ³ /rev
19= 19.2 cm ³ /rev	33= 33 cm ³ /rev
22= 22.2 cm ³ /rev	
26= 26.2 cm ³ /rev	

24 Version

Omitted if 12 teeth standard
 LN= 12 teeth Low Noise version

27 Type of ports code

see section 3.5 AP212 and AP212HP Catalogues

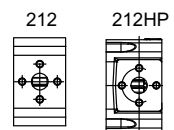

28 Inlet/outlet port size code combination

see section 3.5 AP212 and AP212HP Catalogues



29 Body material + seal material code

see section 3.5.1 AP212 and AP212HP Catalogues

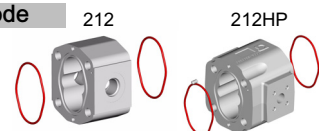

30 Back cover type / Valve setting value

see section 3.6 AP212 and AP212HP Catalogues

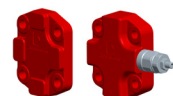

31 For Tandem or multiple pumps with or without shaft seal between the pumps

Omitted if without shaft seal between the pumps (standard versions)
 P= with shaft seal between the pumps (special versions)

4.5 Multiple gear pumps: AP250HP+AP250HP+AP212 standard versions

Standard versions means separated inlet/outlet side ports, without shaft seal between pump stages

4.5.1 Drive torque calculation example

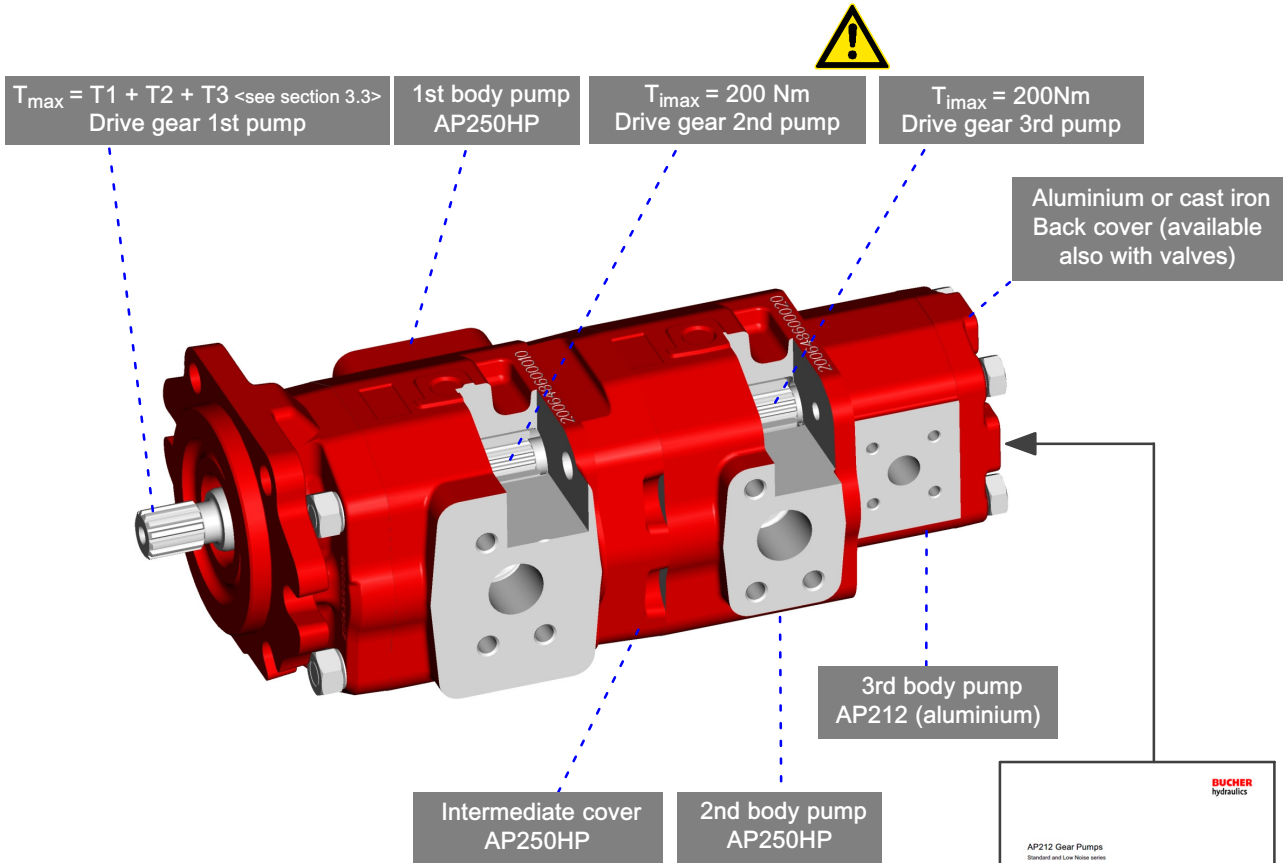

$$T_{\max} = 1.59 \cdot \frac{p_1 \cdot V_{c1}}{\eta_{m1}} + 1.59 \cdot \frac{p_2 \cdot V_{c2}}{\eta_{m2}} + 1.59 \cdot \frac{p_3 \cdot V_{c3}}{\eta_{m3}}$$

Example: AP250HP/40 + AP250HP/33 + AP212/6.5

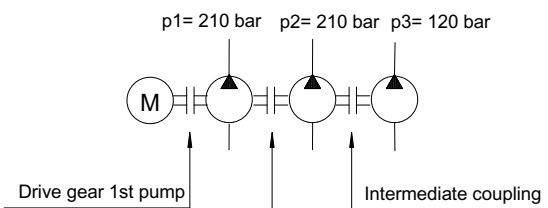

$$T_{\max} = 1.59 \cdot \frac{40 \cdot 210}{90} + 1.59 \cdot \frac{33 \cdot 210}{90} + 1.59 \cdot \frac{6.5 \cdot 120}{90} = 148.4 + 122.43 + 13.78 = 284.61 \text{ Nm}$$

$$T_{\max} = 284.61 \leq 460 \text{ Nm (splined 15T)}$$

$$T_2 = 33.57 \leq T_{\max} 200 \text{ Nm}$$



Further information regarding group 2 pumps: see dedicated "AP212 Gear Pumps" catalogue

Common suction versions available on request.
Please contact our Sales Department.

4.5.2 AP250HP + AP250HP + AP212 pumps dimensions

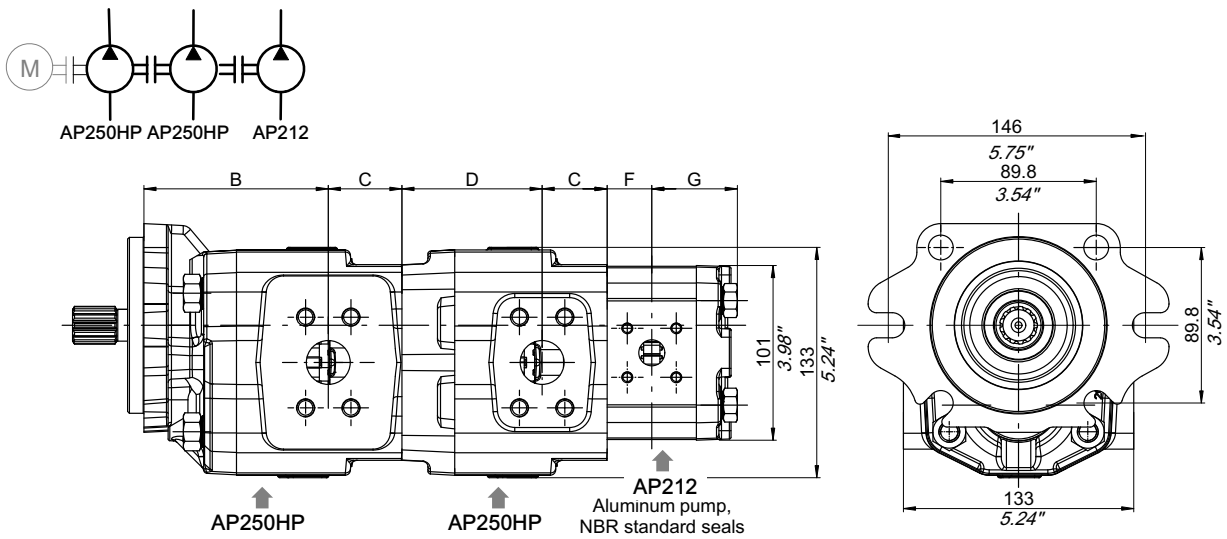

Pump size AP250HP	B		C		D	
	mm	inches	mm	inches	mm	inches
AP250HP/15	85.5	3.37	37.5	1.48	62.5	2.46
AP250HP/19	89.5	3.52	37.5	1.48	66.5	2.62
AP250HP/23	93.5	3.68	37.5	1.48	70.5	2.78
AP250HP/26	97	3.82	37.5	1.48	74	2.91
AP250HP/29	100	3.94	37.5	1.48	77	3.03
AP250HP/33	104	4.09	37.5	1.48	81	3.19
AP250HP/36	102	4.02	42.5	1.67	79	3.11
AP250HP/40	106.5	4.19	42.5	1.67	83.5	3.29
AP250HP/45	111.5	4.39	42.5	1.67	88.5	3.48
AP250HP/50	116.5	4.59	42.5	1.67	93.5	3.68
AP250HP/54	120.5	4.74	42.5	1.67	97.5	3.84

Pump size AP212	F		G	
	mm	inches	mm	inches
AP212/4.5	24.3	0.96	46.6	1.83
AP212/6.5	25.8	1.02	48.1	1.89
AP212/8.5	27.3	1.08	49.6	1.95
AP212/11	29.3	1.54	51.6	2.03
AP212/15	32.3	1.27	54.6	2.15
AP212/19	35.3	1.39	57.6	2.27
AP212/22	37.6	1.48	59.9	2.36
AP212/26	40.6	1.60	62.9	2.48

4.5.3 Dimensions example

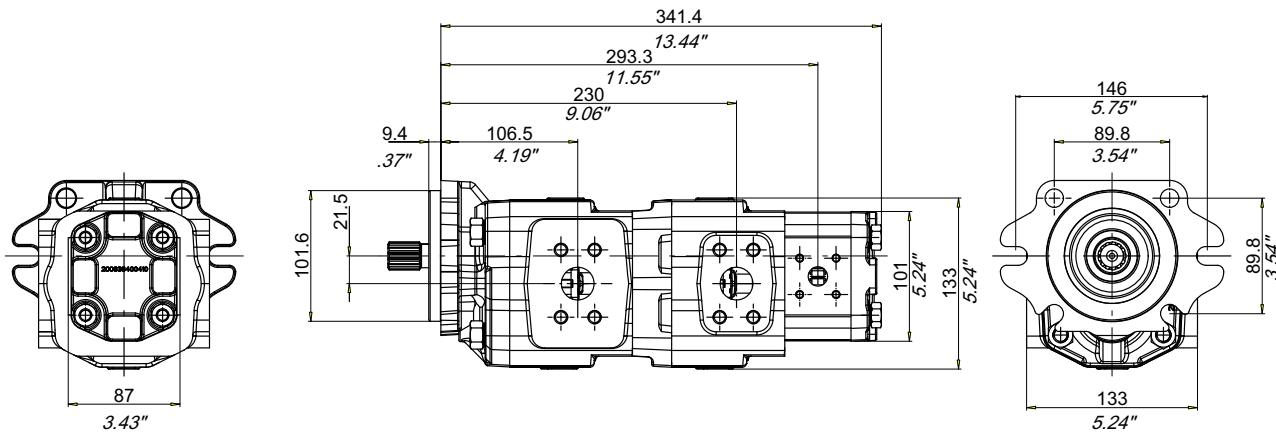

Example AP250HP/40 + AP250HP/33 + AP212/6.5:

Total length: $341.4 = (B+C+D+C+F+G)$ $106.5+42.5+81+37.5+25.8+48.1$

Port position: $293.3 = (B+C+D+C+F)$ $106.5+42.5+81+37.5+25.8$

$230 = (B+C+D)$ $106.5+42.5+81$

$106.5 = (B)$

4.5.4 How to order triple pumps AP250HP + AP250HP + AP212 standard versions

1st PUMP			2nd PUMP			3rd PUMP			1st BODY AP250HP		2nd BODY AP250HP		3rd BODY AP212																											
1	2	3	3	22	23	4	5	6	7	8	7	8	27	28	29	30																								
A	P	2	5	0	H	P	/	3	6	-	3	3	-	2	1	2	/	1	1	-	S	-	S	3	8	B	8	G	A	-	8	G	A	-	8	A	N	-	G	H

AP250HP

1 Function

AP= single gear pump - unidirectional

2 Series

250HP

3 Displacement

15= 15.2 cm³/rev
 19= 19.1 cm³/rev
 23= 23 cm³/rev
 26= 26.4 cm³/rev
 29= 29.3 cm³/rev
 33= 33.2 cm³/rev
 36= 36.1 cm³/rev
 40= 40.5 cm³/rev
 45= 45.3 cm³/rev
 50= 50.2 cm³/rev
 54= 54 cm³/rev

4 Rotation

S = left-hand rotation
 D = Right-hand rotation

5 Shaft end code

see section 3.3

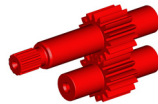

6 Front cover type

see section 3.4.1

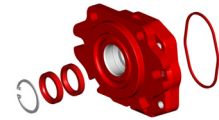

7 Type of ports code

see section 3.4.2

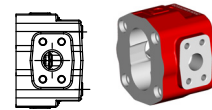

8 Inlet/outlet port size code combination

see section 3.4.2

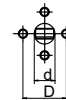

9 BHRE section :

Version - Progressive number (omitted)

AP212 - AP212HP

22 Series

212 (Aluminium)
 212HP (Cast iron)

23 Displacement

212	212HP
4.5= 4.4 cm ³ /rev	15= 15.1 cm ³ /rev
6.5= 6.4 cm ³ /rev	19= 19.2 cm ³ /rev
8.5= 8.4 cm ³ /rev	22= 22.2 cm ³ /rev
11= 11.1 cm ³ /rev	26= 26.2 cm ³ /rev
15= 15.1 cm ³ /rev	29= 28.9 cm ³ /rev
19= 19.2 cm ³ /rev	33= 33 cm ³ /rev
22= 22.2 cm ³ /rev	
26= 26.2 cm ³ /rev	

24 Version

Omitted if 12 teeth standard
 LN= 12 teeth Low Noise version

27 Type of ports code

see section 3.5 AP212 and AP212HP Catalogues

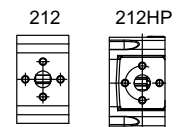

28 Inlet/outlet port size code combination

see section 3.5 AP212 and AP212HP Catalogues



29 Body material + seal material code

see section 3.5.1 AP212 and AP212HP Catalogues

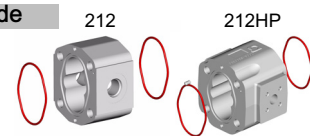

30 Back cover type / Valve setting value

see section 3.6 AP212 and AP212HP Catalogues

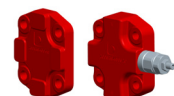

5 Circuits/valves option

For Technical features and availability please contact our Sales Department

5.1 Load sensing circuits

5.1.1 Load sensing valve rear cover assembly position

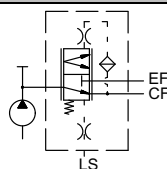
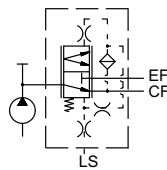
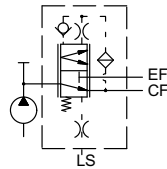
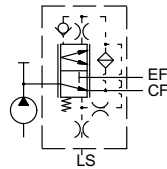
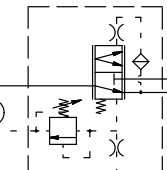
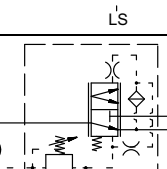
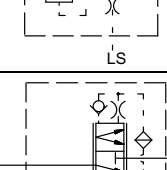
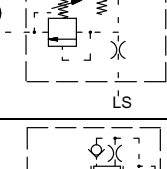
Hydraulic scheme	Family	Description	Code
	STATIC	Static LS signal	LSB01
	DYNAMIC	Dynamic LS signal	LDB01
	STATIC	Static LS signal + check valve on CF line	LSB02
	DYNAMIC	Dynamic LS signal + check valve on CF line	LDB02
	STATIC	Static LS signal + relief valve on LS signal	LSB03
	DYNAMIC	Dynamic LS signal + relief valve on LS signal	LDB03
	STATIC	Static LS signal + check valve on CF line and relief valve on LS signal	LSB04
	DYNAMIC	Dynamic LS signal + check valve on CF line and relief valve on LS signal	LDB04

5.1.2 Load sensing valve lateral assembly position

Hydraulic scheme	Family	Description	Code
	STATIC	Static LS signal	LSS01
	DYNAMIC	Dynamic LS signal	LDS01
	STATIC	Static LS signal + check valve on CF line	LSS02
	DYNAMIC	Dynamic LS signal + check valve on CF line	LDB02

5.2 Max pressure relief valve circuits

Hydraulic scheme	Description	Code
	Fixed setting relief valve with internal tank line	VMI01
	Fixed setting relief valve with external tank line	VME01

6 Product identification plate

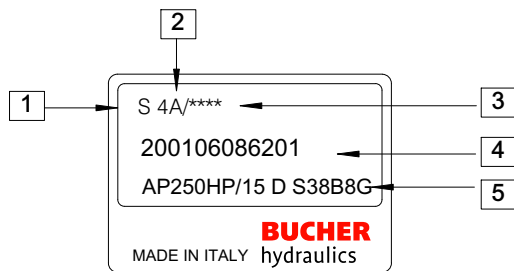

1 : Rotation (D= Clockwise rotation - S= Counterclockwise rotation)

2 : Manufacturing year and month

3 : Progressive identification no. (optional)

4 : Bucher Hydraulics S.p.A. product code

5 : Description

Manufacturing month	Manufacturing year					
	2014	2015	2016	2017	2018	2019
January	4A	5A	6A	7A	8M	9M
February	4B	5B	6B	7B	8N	9N
March	4C	5C	6C	7C	8P	9P
April	4D	5D	6D	7D	8Q	9Q
May	4E	5E	6E	7E	8R	9R
June	4F	5F	6F	7F	8S	9S
July	4G	5G	6G	7G	8T	9T
August	4H	5H	6H	7H	8U	9U
September	4I	5I	6I	7I	8V	9V
October	4J	5J	6J	7J	8Z	9Z
November	4K	5K	6K	7K	8X	9X
December	4L	5L	6L	7L	8Y	9Y

7 Application form

Date:			
Contact:			
Customer:			
Location:			
Overall quantity per year:			
Minimum batch size:			
Delivery time requested:	Feasibility:	Prototypes:	Series:
Target price:			
Type of application:			

External gear pump general data					
Rotation	S	D	R	Speed range	
Displacement: Single pump (cm ³ /rev)				Continuous work pressure (bar)	1st 2nd 3rd
Double pump (cm ³ /rev)	1st	2nd		Peak work pressure (bar)	1st 2nd 3rd
Multiple pump (cm ³ /rev)	1st	2nd	3rd	Oil type	
Drive shaft				Oil temperature (°C)	min max
Port type				Oil viscosity (cSt)	min max
Front cover type				Suction line pressure	
Bearing support				Voltage	
Front cover material				Drain case pressure	
Intermediate cover (with or without shaft seal)	with	without		Radial load (N)	
Back cover type/circuit				Axial load (N)	
Back cover material	aluminium	cast iron		Working hours per year	
Valves				Cycles per year	

Additional notes:

info.it@bucherhydraulics.com

www.bucherhydraulics.com

© 2016 by Bucher Hydraulics S.p.A, I-42124 Reggio Emilia

All rights reserved.

Data is provided for the purpose of product description only, and must not be construed as warranted characteristics in the legal sense. The information does not relieve users from the duty of conducting their own evaluations and tests. Because the products are subject to continual improvement, we reserve the right to amend the product specifications contained in this catalogue.

Classification: 410.110.000